

# PSE Technology Corporation

## SPECIFICATION FOR APPROVAL

CUSTOMER \_\_\_\_\_

NOMINAL FREQUENCY \_\_\_\_\_ 32.768 KHz \_\_\_\_\_

PRODUCT TYPE \_\_\_\_\_ **TYPE G4 SMD X'TAL** \_\_\_\_\_

SPEC. NO. ( P/N ) \_\_\_\_\_ G43270025 \_\_\_\_\_

CUSTOMER P/N \_\_\_\_\_

ISSUE DATE \_\_\_\_\_ Jul.25,2016 \_\_\_\_\_

VERSION \_\_\_\_\_ B \_\_\_\_\_

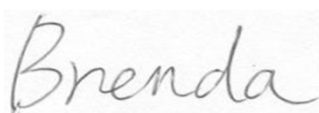
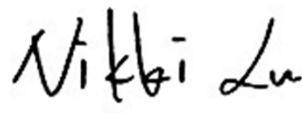
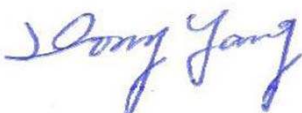
APPROVED	PREPARED	QA
		
<b>APPROVED BY CUSTOMER :</b>		<b>AVL Status</b>
Please return one copy with approval to PSE-TW		

### PSE Technology Corporation

No.2, Tzu-Chiang 5th Rd, Chung Li Industrial Park,  
 Chung Li City, Taoyuan County, Taiwan (R.O.C.)  
 TEL: 886-3-451-8888  
 FAX: 886-3-461-3865  
<http://www.saronix-ecera.com.tw>

- \*RoHS Exception
- \*HF-Halogen Free
- \*REACH Compliant

# TYPE G4 SMD X'TAL

**G43270025**

VER. B 25-Jul-16

## VERSION HISTORY

Version No.	Version Date	Customer Receipt Date	Supplier Receipt Date	Description	Notes
A	Aug.1,2013			Initial Release	
B	Jul.25,2016			Revised Shunt Capacitance to 1.45pF typ.	



# TYPE G4 SMD X'TAL

G43270025

VER. B 25-Jul-16

## ELECTRICAL SPECIFICATIONS

SRe Part Number : G43270025

Parameters	Symbol	Specifications	Units	Notes
Nominal Frequency	Fn	32.768	KHz	
Frequency Tolerance	FT	± 20	ppm	at 25 °C ± 5 °C, measured at max drive level
Load Capacitance	CL	12.5	pF	Typ.
Drive Level	DL	1	μW	Max.
Equivalent Series Resistance	ESR	50	KΩ	Max.
Temperature Coefficient	K	-0.034 ± 0.01	ppm/°C <sup>2</sup>	measured at max drive level
Shunt Capacitance	C0	1.45	pF	Typ.
Capacitance Ratio	C0/C1	450		Typ.
Operating Temperature Range	TR	-40~85	°C	
Storage Temperature Range		-55~85	°C	
Aging		± 5	ppm	Max. per year
Insulation Resistance		500	MΩ	Min.

## Reliability ( Mechanical and Environmental Endurance )

No.	Test Items	Test Method and Condition	Requirements
1	Vibration	(1) Vibration Frequency: 10 to 55Hz (2) Vibration Amplitude: 1.5mm (3) Cycle Time: 1-2min(10-55-10Hz) (4) Direction: X.Y.Z (5) Duration: 2h/each direction	Frequency Change: ±10ppm Max. Resistance Change: ±15% or 5kΩ Max.
2	Shock	3 Times free drop from 75cm height to hard wooden board of thickness more than 30mm	Frequency Change: ±10ppm Max. Resistance Change: ±15% or 5kΩ Max.
3	Leakage	Put crystal units into a hermetic container and Helium for 0.5-0.6Mpa, and keep it for 1h; Check the leakage by a Helium leak detector	Leakage: 1x10 <sup>-8</sup> Pa·m <sup>3</sup> /s Max.

# TYPE G4 SMD X'TAL

G43270025

VER. B 25-Jul-16

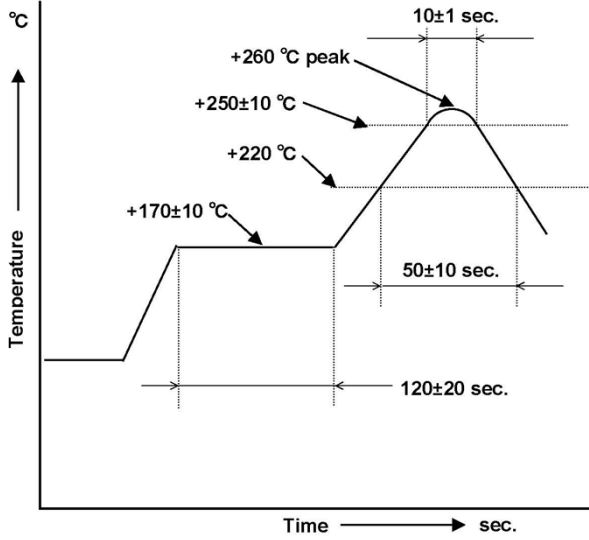
4	Reflow soldering	 <p>Note: the temperature used herein means the temperature on the circuit board. Reflow: 2 times max.</p>	<p>Frequency Change: <math>\pm 10</math>ppm Max. Frequency Change: <math>\pm 10</math>ppm Max. Resistance Change: <math>\pm 25\%</math> or 10k<math>\Omega</math> Max.</p>
5	Lead Strength (DIP)	The crystal lead with the 0.9kg(9N) power (keep it for 30s $\pm$ 5s) and bend the crystal lead 90° with 0.45kg power and two times	The crystal lead is not abnormality
6	High Temperature Endurance	The crystal units shall be put in somewhere for 2 hrs at temperature of -85 $\pm$ 2 $^{\circ}$ C, then keep it for 1 to 2 hrs under room temperature.	<p>Frequency Change: <math>\pm 10</math>ppm Max. Resistance Change: <math>\pm 15\%</math> or 5k<math>\Omega</math> Max.</p>
7	Low Temperature Endurance	The crystal units shall be put in somewhere for 2 hrs at temperature of -25 $^{\circ}$ C, then keep it for 1 to 2 hrs under room temperature.	
8	Humidity Endurance	The crystal units shall be put in somewhere at 40 $^{\circ}$ C in relative humidity of 90-95% for 48 hrs, then keep it for one or two hours under room temperature.	
9	Temperature Cycle	Temperature shift from low(-40 $^{\circ}$ C) to high(100 $^{\circ}$ C, keep 30 mins), satisfy high(100 $^{\circ}$ C) to low(-40 $^{\circ}$ C, keep 30 mins), then go up to room temperature for 5 cycles.	
10	Salt Spray Test	Put the crystal units in the salt spray room (salt density: 5%) at the temperature of 35 $^{\circ}$ C for 96 hrs. Then clean it with water and dry its surface.	<p>The appearance shall has no abnormality and soldering is good. Frequency Change: <math>\pm 10</math>ppm Max. Resistance Change: <math>\pm 15\%</math> or 5k<math>\Omega</math> Max.</p>

# TYPE G4 SMD X'TAL

G43270025

VER. B 25-Jul-16

## Marking

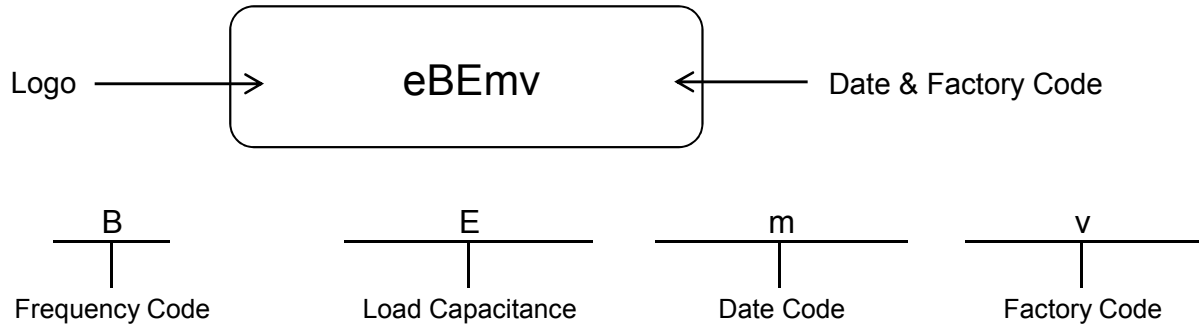

## Outline Dime (Units: mm)

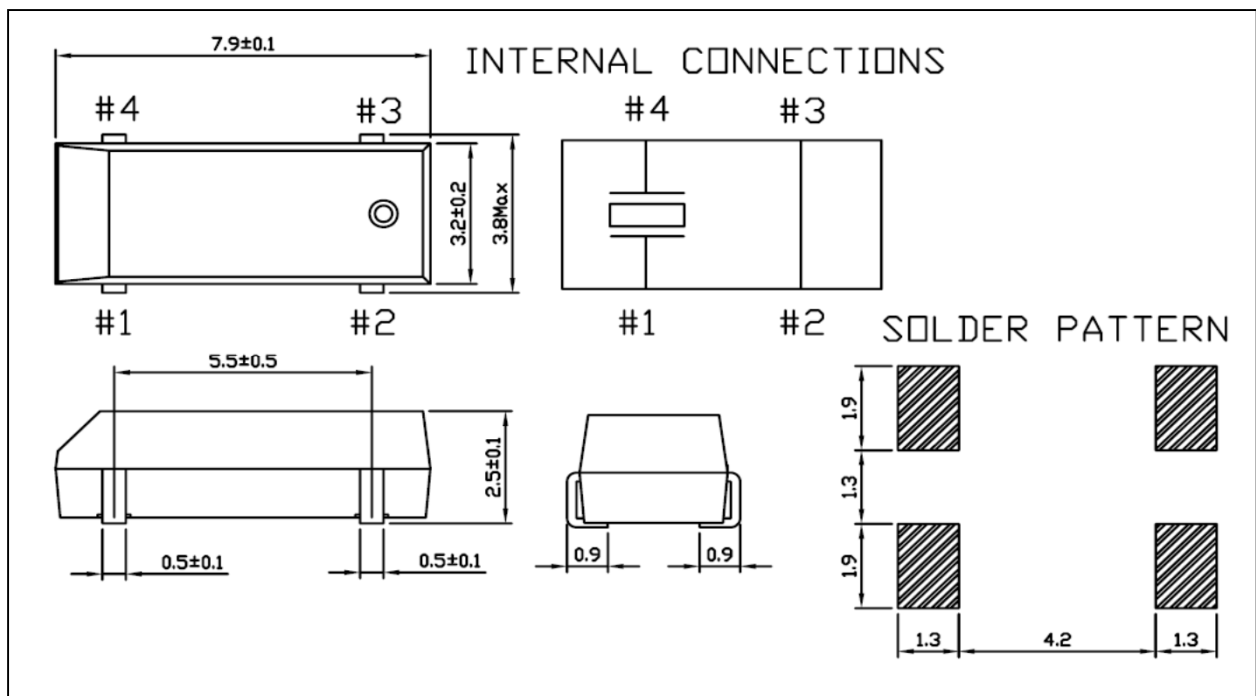

# TYPE G4 SMD X'TAL

**TAPE AND REEL SPECIFICATION**

1. Tape and Reel form conform to EIA-481-B
2. The quantity of crystal units per reel shall be 3000PCS.
3. A "LABEL" on which necessary information is clearly written is on the surface of packing box and the reel.

**CARRIER TAPE DIMENSIONS**

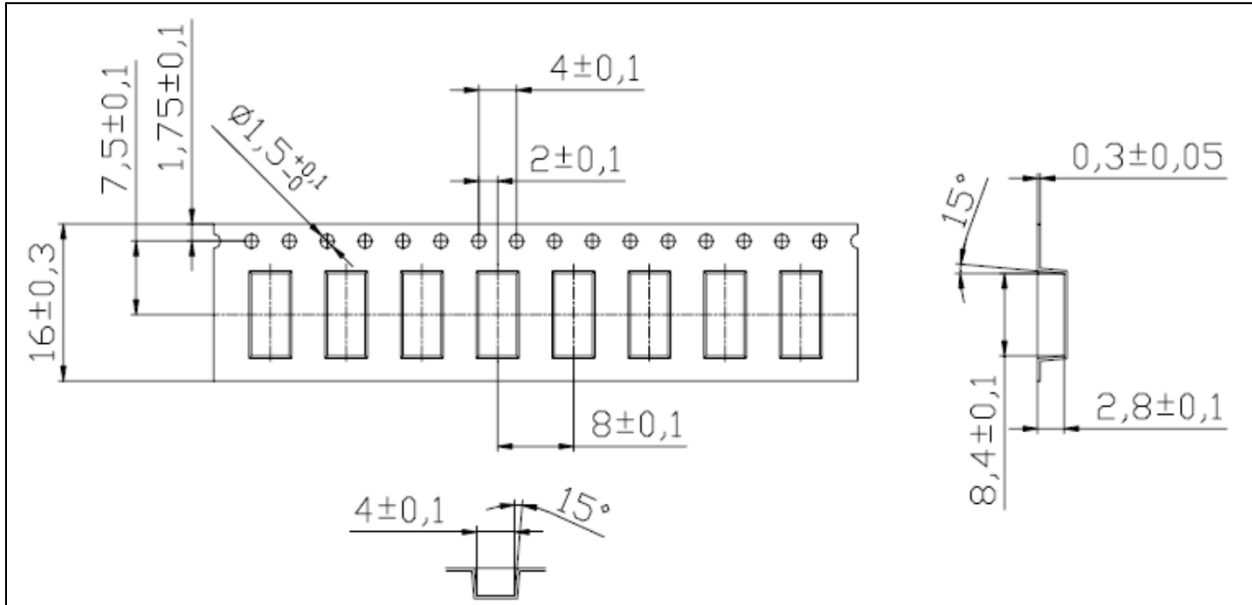

**REEL DIMENSIONS**

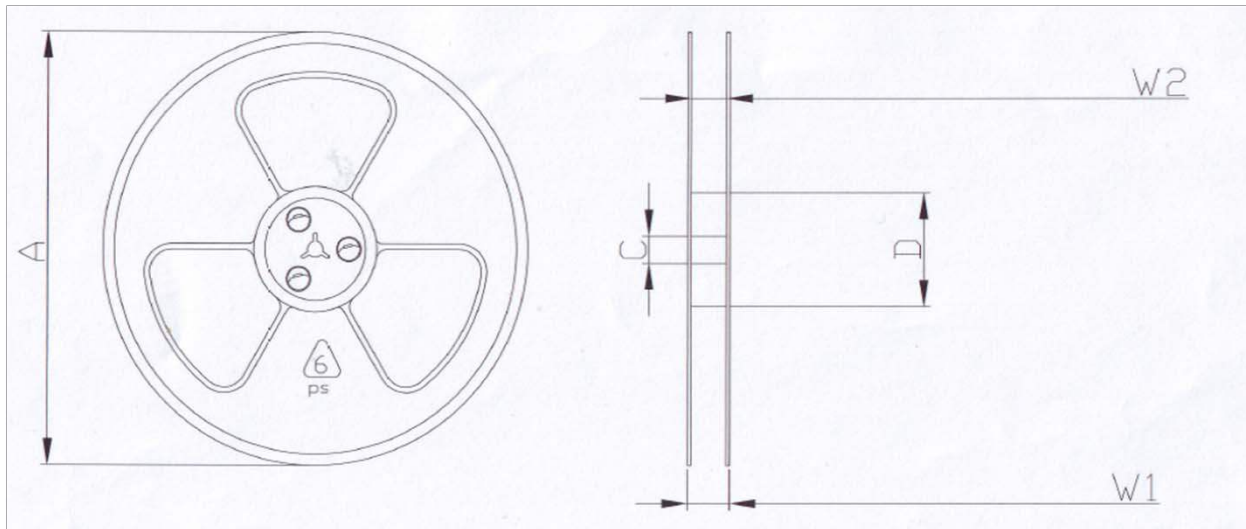

規格	$A \pm 0.5$	$C \pm 0.2$	$D \pm 0.3$	$W1 \pm 0.2$	$W2^{+0.4}_{+0.2}$
330*100*16	330	25	100	20	16

