

THIS DRAWING IS UNPUBLISHED. RELEASED FOR PUBLICATION 20  
 © COPYRIGHT 20 BY TYCO ELECTRONICS CORPORATION. ALL RIGHTS RESERVED.

LOC	DIST	REVISIONS			
P	LTR	DESCRIPTION	DATE	DWN	APVD
	B	ECR-06-018103	26JUL2006	MJG	JA
	C	ECR-10-007894	12/04/10	MJG	JA
	D	ECR-11-005036	27/07/11	MJG	JA

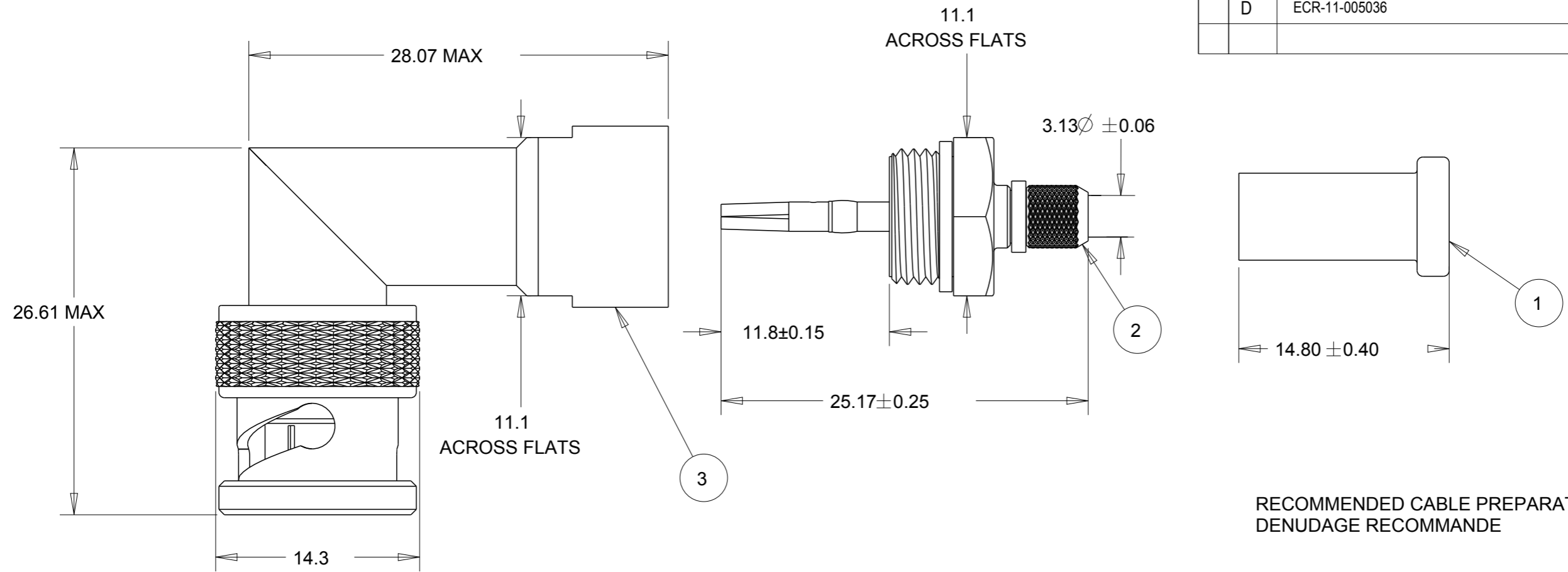

RECOMMENDED CABLE PREPARATION  
DENUDAGE RECOMMANDE

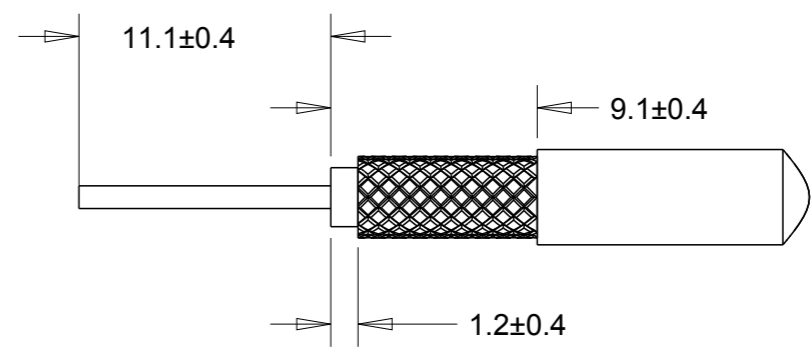

NOTES:

- 1. FOR USE WITH RG-400U KX23 CABLE  
UTILISER AVEC CABLE RG-400U KX23
- 2. CRIMP WITH HAND TOOL Pt No 69376-2 OR 69710 + INSET 69814  
PINCE A SERTIR REF: 69376-2 ou 69710 + MATRICE 69814
- 3. INSTRUCTION SHEET 408-1799-5  
INSTRUCTION DE SERTISSAGE: 408-1799-5

BNC PLUG ASSY RIGHT ANGLE	330797-0	3
JACK CRIMP END	1236007-1	2
FERRULE	1-330927-0	1
DESCRIPTION	PART NO	ITEM

THIS DRAWING IS A CONTROLLED DOCUMENT FOR TYCO ELECTRONICS CORPORATION IT IS SUBJECT TO CHANGE AND THE CONTROLLING ENGINEERING ORGANIZATION SHOULD BE CONTACTED FOR THE LATEST REVISION.		DWN M. GREENER 26JUL2006	<b>STE</b> Tyco Electronics Bideford, Devon EX39 2NY
DIMENSIONS: mm		CHK J AMBROSE 26JUL2006	
TOLERANCES UNLESS OTHERWISE SPECIFIED: 0 PLC ± 1 PLC ±0.3 2 PLC ±0.3 3 PLC ±0.3 4 PLC ± ANGLES ±1		APVD J AMBROSE 26JUL2006	NAME BNC SERIES RIGHT ANGLE PLUG SINGLE CRIMP
MATERIAL SEE TABLE		PRODUCT SPEC 108-12002	
FINISH		APPLICATION SPEC	SIZE A3
		WEIGHT	CAGE CODE 00779
		CUSTOMER DRAWING	DRAWING NO 1236009
		SCALE NTS	RESTRICTED TO
		SHEET 1	OF 1
		REV D	