

LOC		DIST		REVISIONS			
CM	00	P	LTN	DESCRIPTION	DATE	DWN	APVD
		R4		REVISED PER ECR-12-011660	24JAN2013	KH	TM
		R5		REVISED PER ECR-21-118795	01AUG2022	GR	VS

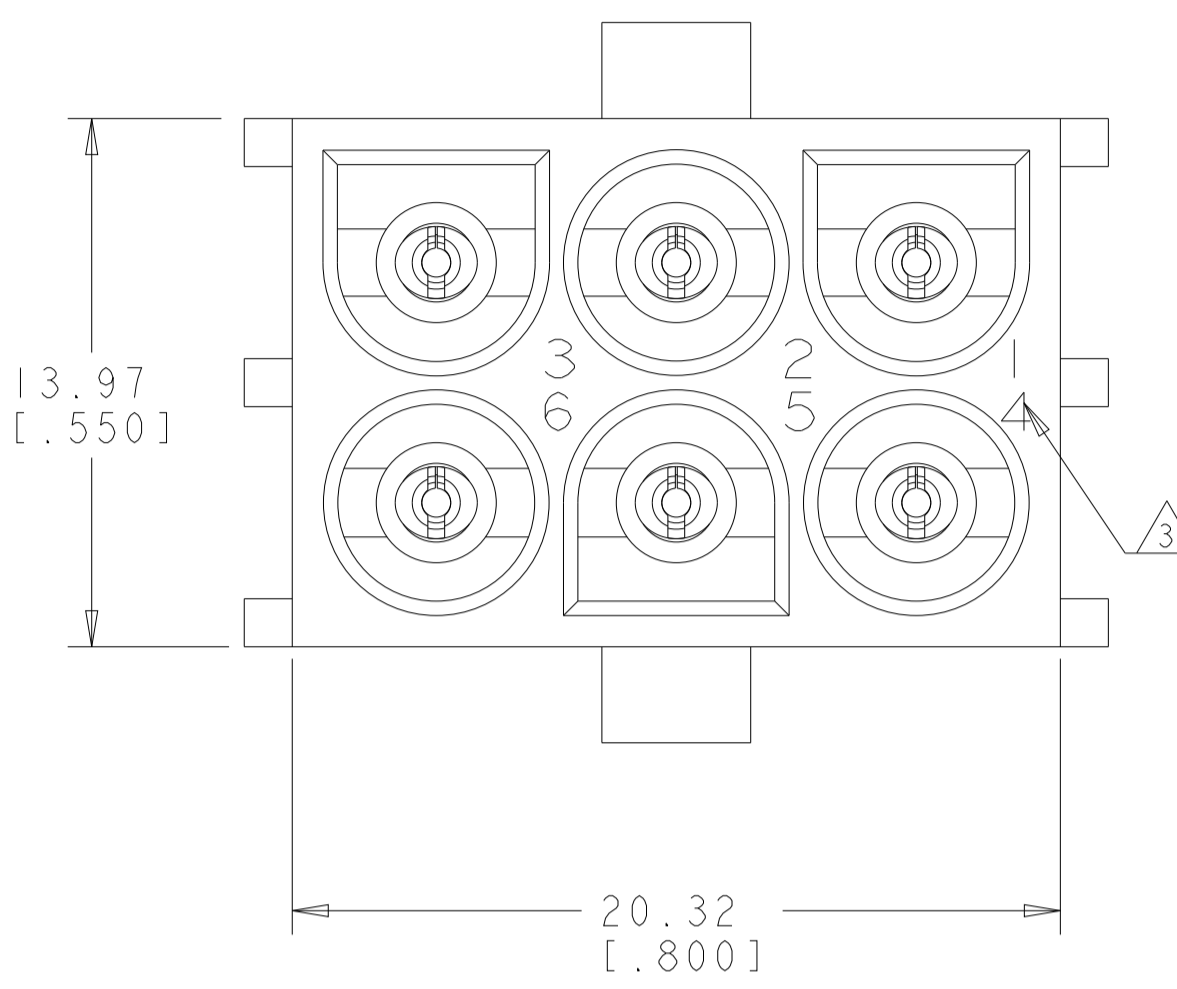

1. PARTS MATE WITH HOUSING 480704.
2. PARTS COMPLY TO AMP SOLDERABILITY SPECIFICATION 109-11-3.
3. CIRCUIT IDENTIFICATION CHARACTERS ARE ADJACENT TO THE INDICATED CAVITIES, BUT LOCATION AND ORIENTATION MAY DIFFER FROM PRINT.
4. CONTACT IS PLATED OVERALL WITH 0.00127 [.000050] NICKEL, THEN 0.00076 [.000030] GOLD OVER CONTACT LENGTH INDICATED AND TIN LEAD ON SOLDER TAIL END.
5. CONTACT IS PLATED OVERALL WITH 0.00127 [.000050] NICKEL, THEN 0.00076 [.000030] GOLD OVER CONTACT LENGTH INDICATED AND MATTE TIN ON SOLDER TAIL END.
6. DIMENSIONS IN BRACKETS ARE IN INCHES.
7. SUPERSEDED BY 350711-4
8. DIMENSION SHOWN REPRESENT PRODUCT IN DRY CONDITION. ADDITIONAL 2% GROWTH DUE TO END USE LOCATION MOISTURE ABSORPTION MAY OCCUR AND SHOULD BE ACCOUNTED FOR.

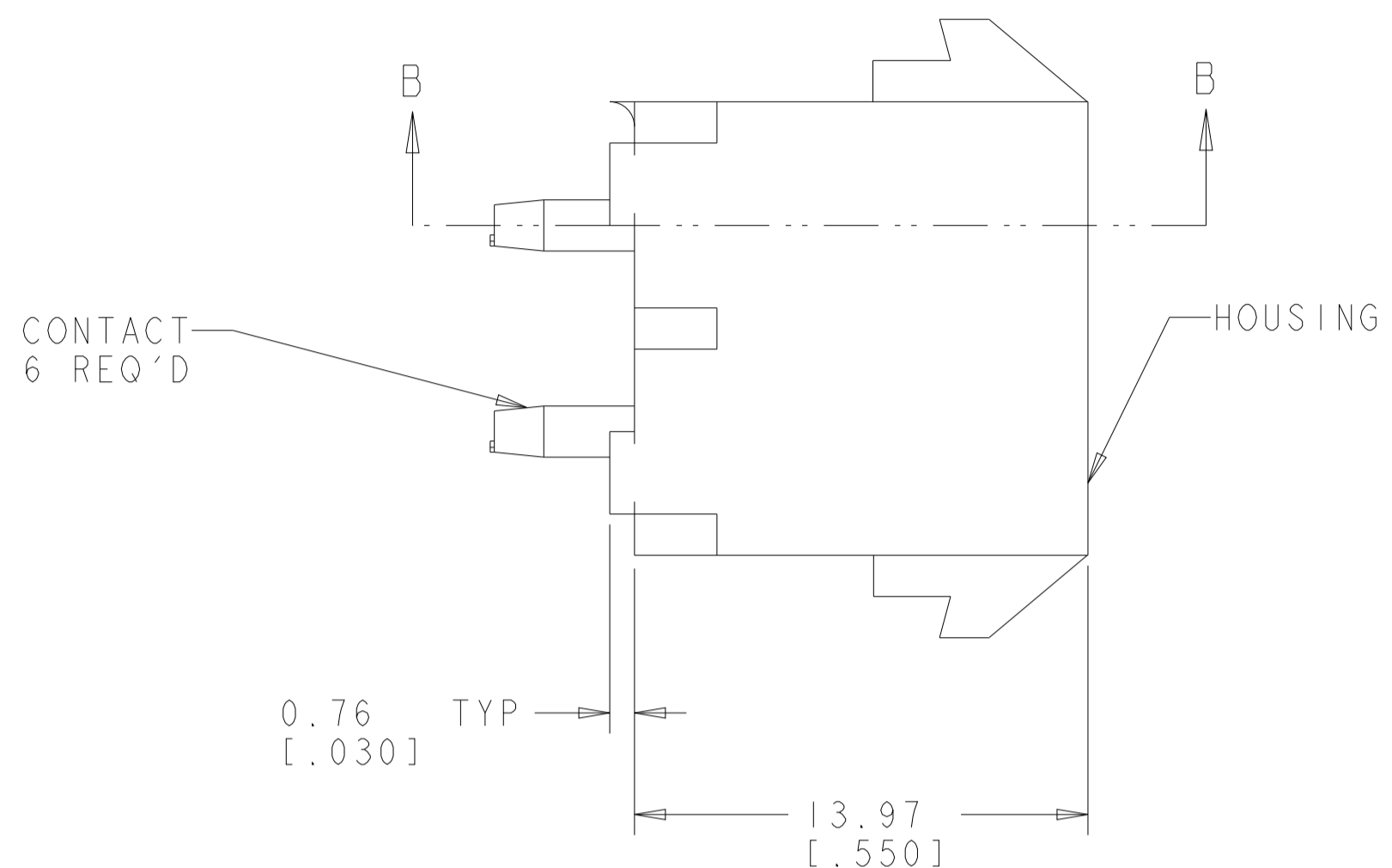
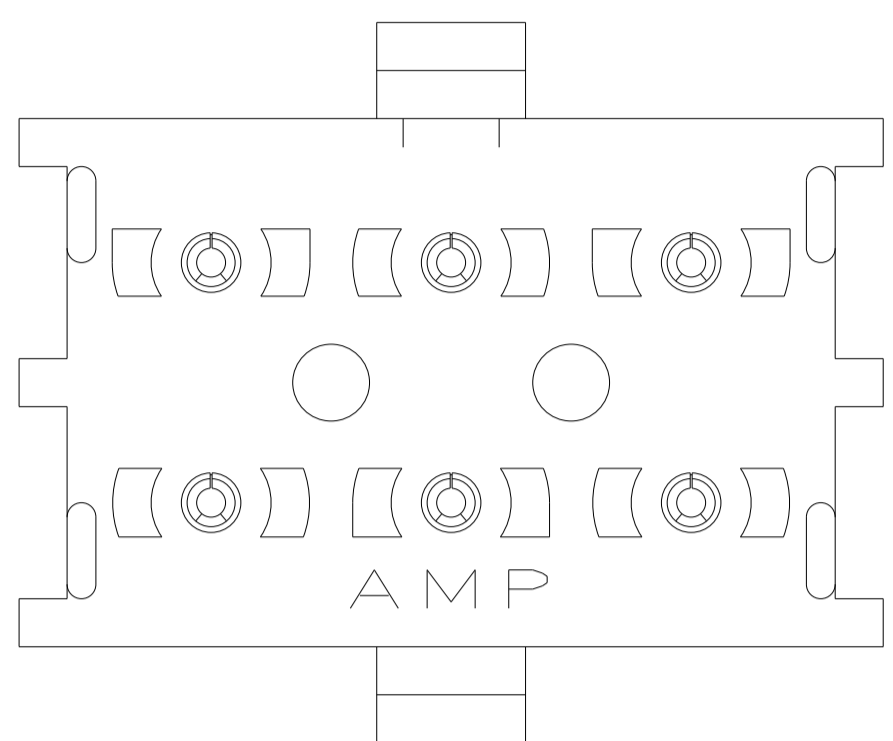
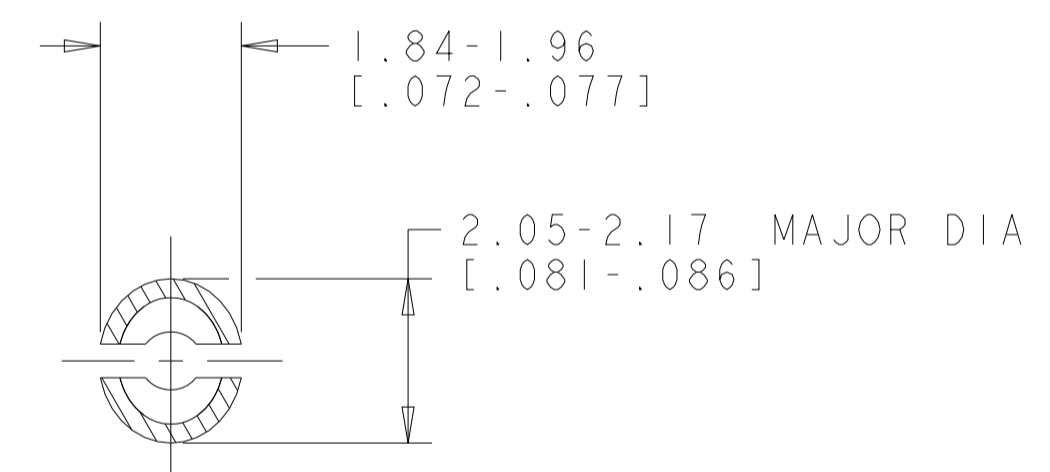
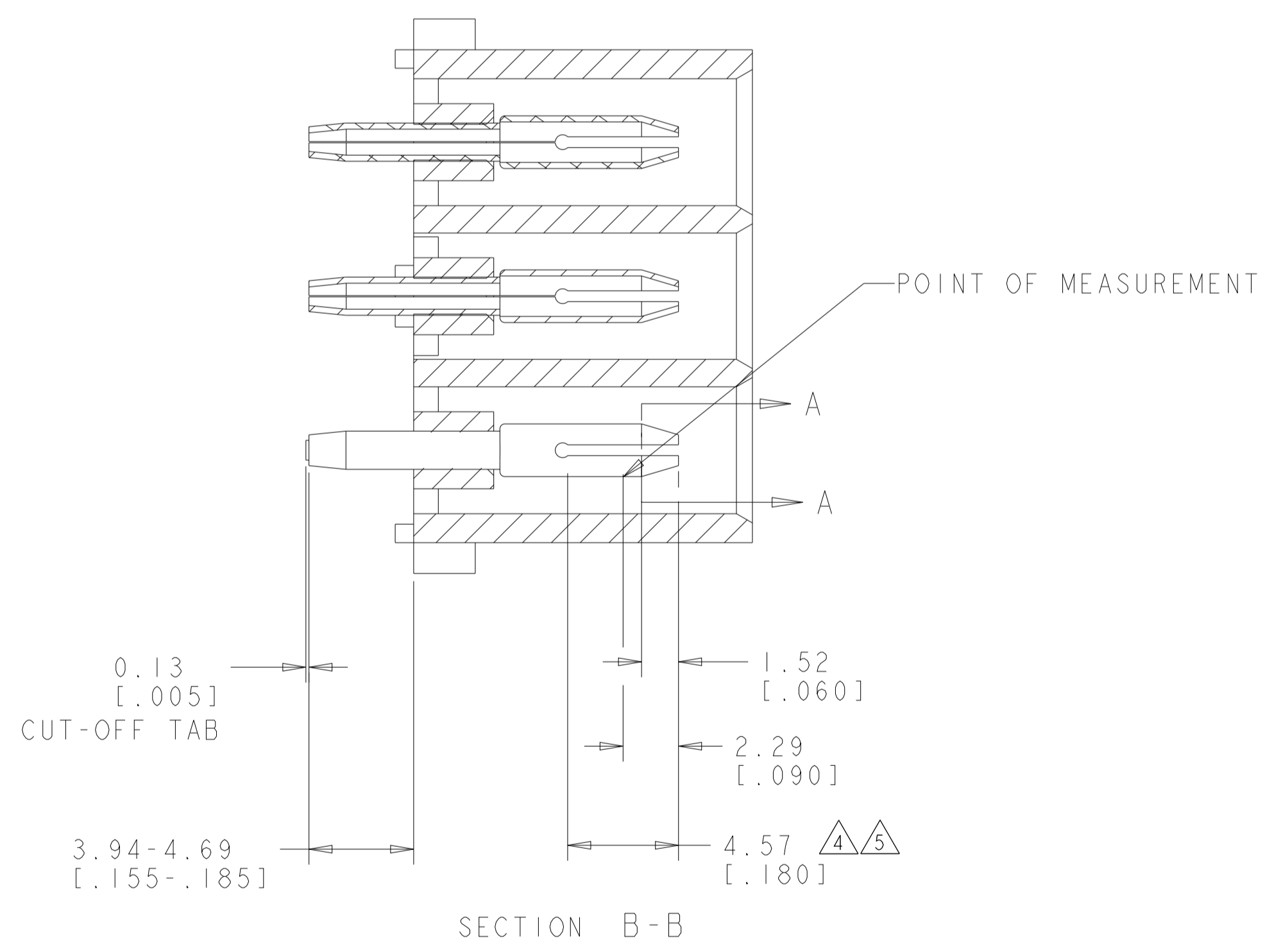

SECTION A-A
SCALE 10:1

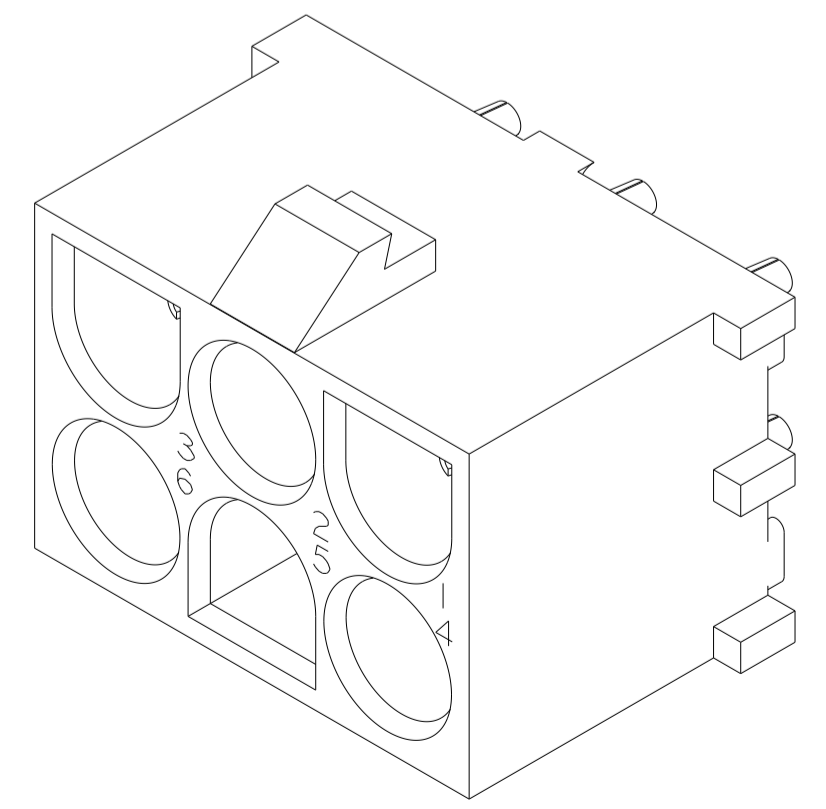

3 DIMENSIONAL MODEL
SCALE 4:1

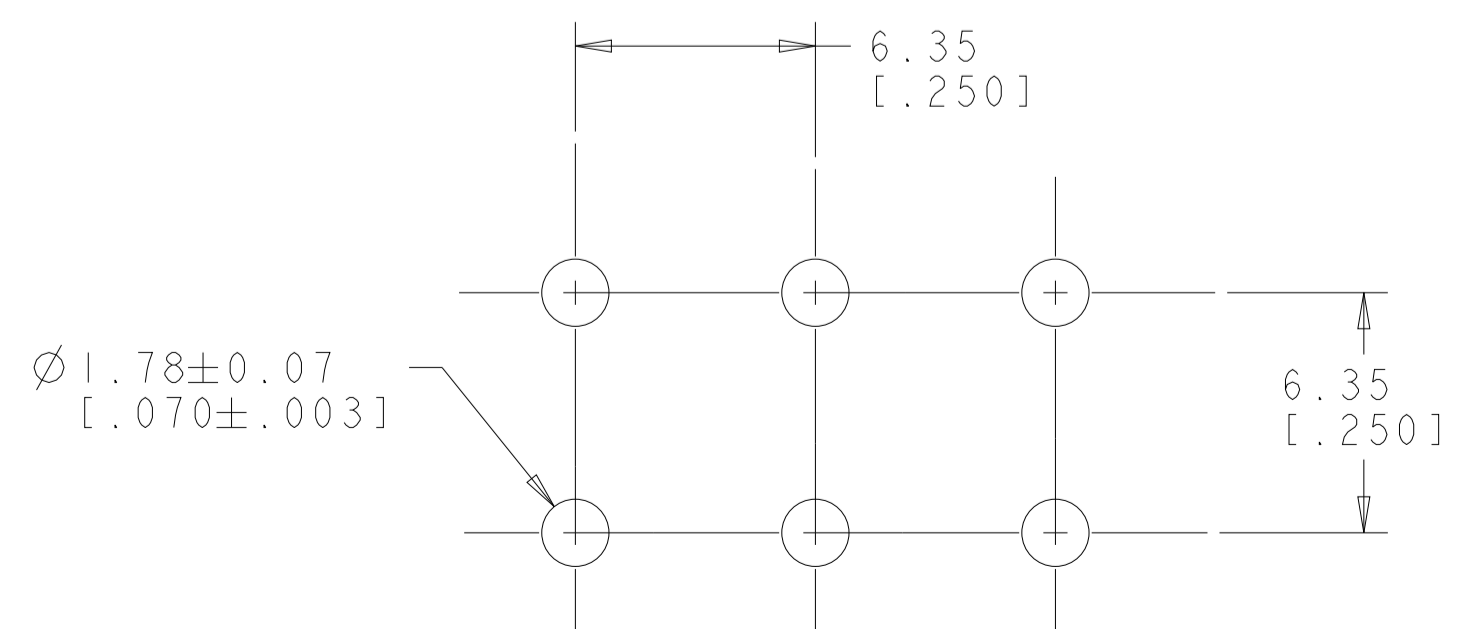

RECOMMENDED MOUNTING HOLE PATTERN
FOR 1.57 [.062] THICK P.C. BOARD

PHOSPOR BRONZE, GOLD 5	NYLON, UL94V-0, NATURAL	350711-4
PHOSPOR BRONZE, GOLD 4	NYLON, UL94V-0, NATURAL	350711-2
PHOSPOR BRONZE, PRE-TIN	NYLON, UL94V-0, NATURAL	350711-1
PIN CONTACT MATERIAL AND FINISH	HOUSING MATERIAL AND COLOR	PART NUMBER

THIS DRAWING IS A CONTROLLED DOCUMENT.		DWN K. WHITAKER 18JULY2005	TE Connectivity
DIMENSIONS: mm [INCHES]		CHK S. RIDGILL 18JULY2005	
TOLERANCES UNLESS OTHERWISE SPECIFIED:		APVD S. RIDGILL 18JULY2005	
0 PLC ± 1 PLC ± 2 PLC ±0.131(.005) 3 PLC ± 4 PLC ± ANGLES ±40°30'		NAME PIN HEADER ASSEMBLY, 6 CIRCUIT, UNIVERSAL MATE-N-LOK(TM)	
MATERIAL SEE TABLE	FINISH SEE TABLE	WEIGHT -	SIZE CAGE CODE DRAWING NO A100779C=350711
CUSTOMER DRAWING		SCALE 5:1	SHEET 1 OF 1 REV R5

