

WT505090-10F2-LP-G(Flexible Type)

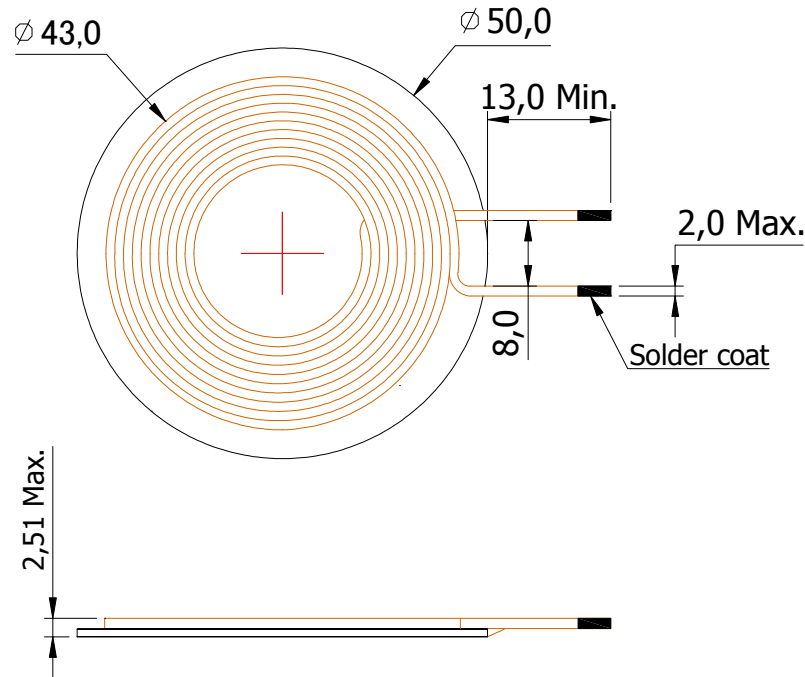

= Dimension of coil unit =



= Coil unit Assembly =

Unit : mm

Stack	TDK Item	Typ.	Max.
1	Coil+Resin	1.05	1.29
2	Adhesive Tape	0.14	0.14
3	PET Tape	0.05	0.05
4	Ferrite Sheet	0.90	0.99
5	PET Tape	0.05	0.05
Total Thickness (Wire parts)		2.19	2.51

= Electrical Characteristics =

- L_s : 6.3 μ H typ. @100kHz
- R_{dc} : 0.06 Ω typ. @100kHz

