

P	LTR	DESCRIPTION	DATE	DWN	APVD
C4		REVISED PER ECN-21-129868	06NOV2021	DRK	NRS
C5		REVISED PER ECR-21-124520	20JAN2022	NS	CB

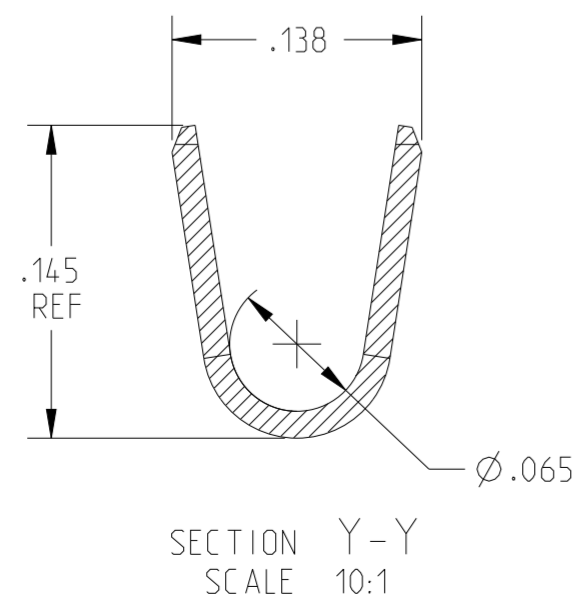
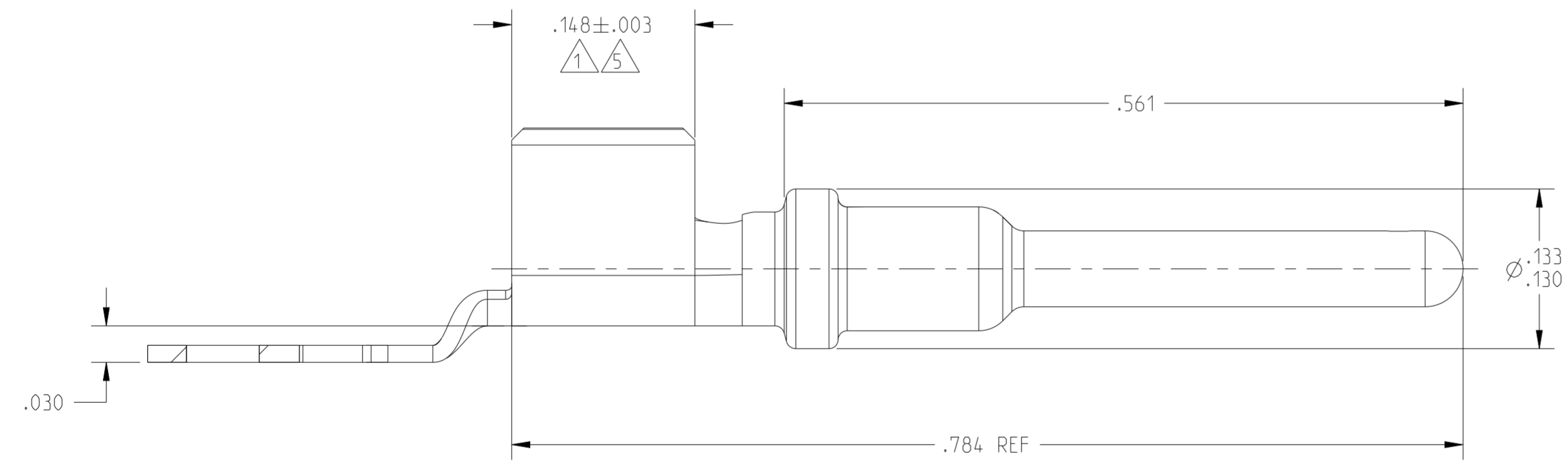
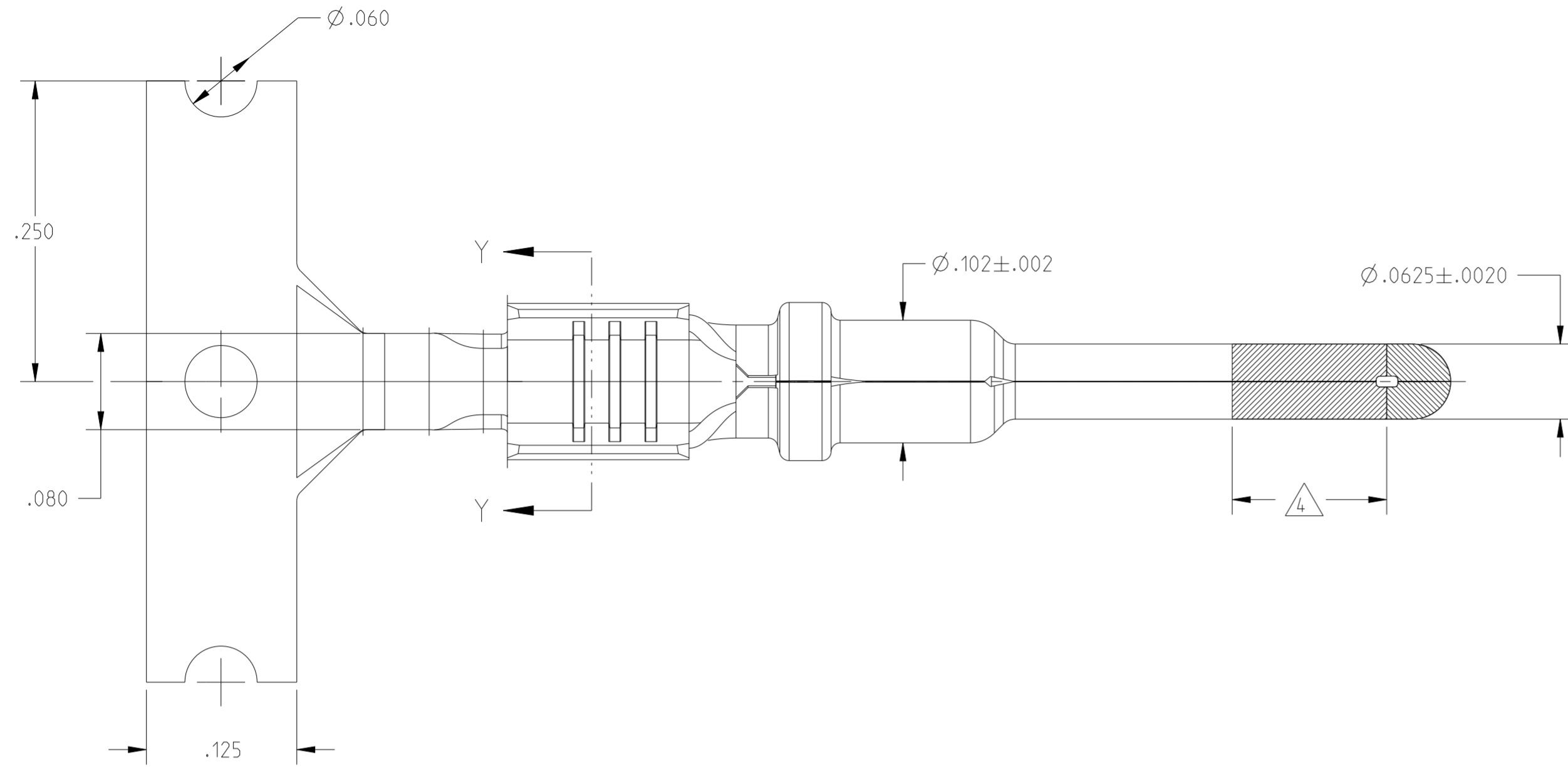

NOTES:

- 1 FINISH: PLATE 0.000100-0.000200 THK TIN IN LOCALIZED TIN PLATE AREA. ALL OVER 0.000030-0.0000070 THK NICKEL.
- 2. CONTACT WILL BE LUBED WITH LUBRICANT PER P/N 22014-1
- 3. WIRE RANGE: 18-14 AWG SXL, GXL, AND TXL WIRE WITH INSL DIAMETERS OF 0.077-0.155 INCHES
- 4 PLATE 0.000030 MIN THK SELECT GOLD IN LOCALIZED PLATE AREA. TIP PLATING AREA PLATE TO 0.000015 MIN THK.
- 5 PLATE 0.000100-0.000200 THK TIN PER 112-65-1 IN LOCALIZED TIN PLATE AREA. ALL OVER 0.000040-0.000080 THK NICKEL PER 112-25-2

5	638112-3
1 4	638112-1

THIS DRAWING IS A CONTROLLED DOCUMENT.		DWN JL MCNEAL	30SEP1997	TE Connectivity	
DIMENSIONS: INCHES		CHK -	APVD W. LONG		
TOLERANCES UNLESS OTHERWISE SPECIFIED:		PRODUCT SPEC		NAME PIN CONTACT, WIRE-TO-WIRE	
0 PLC	±	APPLICATION SPEC		SIZE	CAGE CODE
1 PLC	±	-		A2	00779
2 PLC	±0.02	-		DRAWING NO C-638112	
3 PLC	±0.005	-		RESTRICTED TO	
4 PLC	±	-		-	
ANGLES	±	WEIGHT		-	
FINISH	-	CUSTOMER DRAWING		SCALE	10:1
BODY: 0.014 THK COPPER ALLOY	-	-		SHEET	1 OF 1
	-	-		REV	C5