

DATE	REV	ECN	APP'D. BY
02/23/21	A0	-	JME
03/29/21	A1	11724	BTS
06/01/21	A2	11760	BTS
08/17/21	A3	11805	BTS

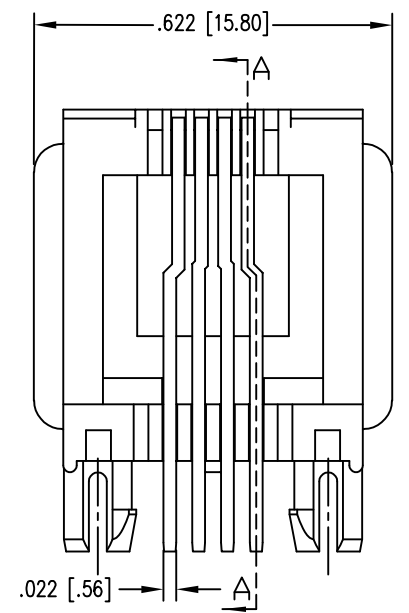
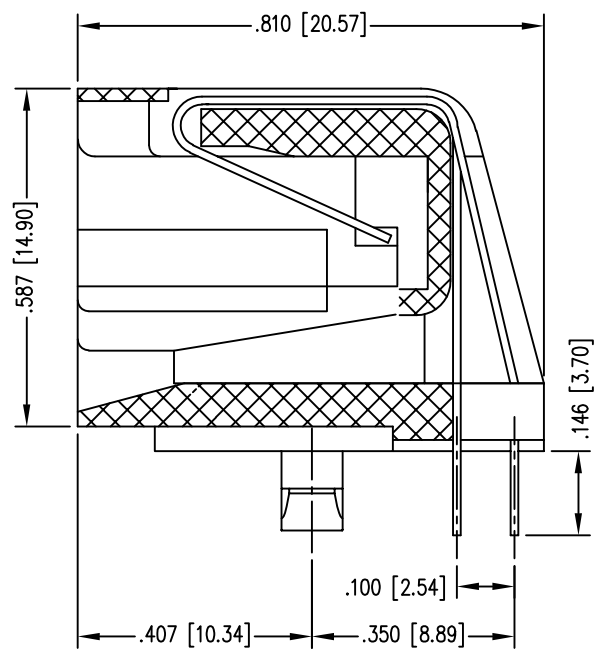
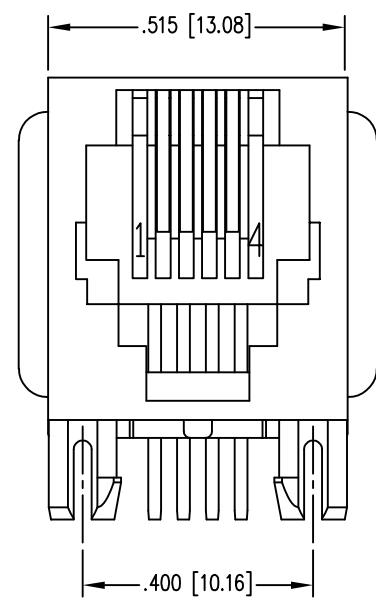

SECTION A-A

NOTES:

- CONNECTOR MATERIALS**
HOUSING: THERMOPLASTIC UL94 V-0
CONTACT PLATING: SELECTIVE GOLD OR EQUIVALENT IN THE CONTACT AREA
SEE CHART FOR PART NUMBER
- OPERATING LIFE: 750 CYCLES MIN
- DIMENSIONS AND TOLERANCES COMPLY WITH TIA-1096 STANDARD.
- ELECTRICAL**
VOLTAGE RATING: 150 VAC RMS
CURRENT RATING: 1.5 AMP
CONTACT RESISTANCE: 20 mΩ MAX
INSULATION RESISTANCE: 1000 MΩ MIN @ 500 VDC.
DIELECTRIC STRENGTH: 1000 V AC OR 1500V DC RMS @ 0.5 mA 50 Hz / 60 Hz 1 MINUTE
- ENVIRONMENTAL**
STORAGE TEMPERATURE: -40° C TO 85° C
OPERATIONAL TEMPERATURE: -40° C TO 85° C

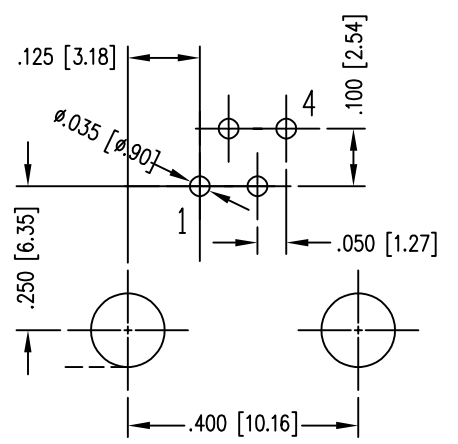

RECOMMENDED PCB FOOTPRINT (COMPONENT SIDE)

15 MICRO-INCHES [0.38um]	SS-90000-006
CONTACT PLATING IN MATING AREA	PART NUMBER

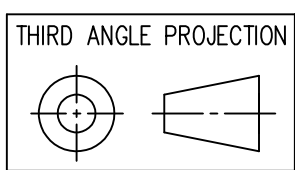

11118 Susquehanna Trail South
Glen Rock, PA 17327-9199
(717) 235-7512
<http://www.stewartconnector.com>

DO NOT SCALE DRAWING
DRAWING IS SUBJECT TO CHANGE WITHOUT NOTICE
DIMENSIONS: INCHES [METRIC]
UNLESS OTHERWISE SPECIFIED TOLERANCES ARE ±.005 [0.13] ANGLES ARE ± 1°
SHEET NO. 1 OF 1

TITLE: RJ11 RIGHT ANGLE JACK, 4 CONTACT, 6 POSITION, UNSHIELDED, PANEL STOP

DRN BY: BTS	DATE: 02/23/21
APPD BY: JME	DATE: 02/23/21
DWG NO. CT900006	REV. A3

THIS DRAWING AND THE SUBJECT MATTER SHOWN THEREON ARE CONFIDENTIAL AND THE PROPRIETARY PROPERTY OF STEWART CONNECTOR AND SHALL NOT BE REPRODUCED, COPIED, OR USED IN ANY MANNER WITHOUT PRIOR WRITTEN CONSENT OF STEWART CONNECTOR. ONE OR MORE U.S. PATENTS MAY APPLY TO THIS PRODUCT. FOR DETAILS, PLEASE VISIT: [HTTP://BELFUSE.COM/STEWART/STEWART_PATENTS/](http://BELFUSE.COM/STEWART/STEWART_PATENTS/)

