

TOSHIBA Bi-CMOS Integrated Circuit Silicon Monolithic

TB6586FG, TB6586AFG

Three-Phase Full-Wave Brushless Motor Controller

The TB6586FG/AFG is a three-phase full-wave brushless motor controller developed for use in motor fans.

Features

- Upper-phase PWM control
- Built-in triangular-wave generator
- Support of a bootstrap circuit
- Built-in Hall amplifier (support of a Hall element)
- Selectable 120°/150° energization
- Built-in lead angle control function
- Overcurrent protection signal input pin ($V_{RS} = 0.5 \text{ V (typ.)}$)
- Built-in regulator ($V_{\text{refout}} = 5 \text{ V (typ.)}$, 35 mA (max))
- Operating supply voltage range: $V_{CC} = 6.5 \text{ to } 16.5 \text{ V}$, $V_M = 4.5 \text{ to } 16.5 \text{ V}$
- The TB6586FG and TB6586AFG differ in the number of pulses per revolution:
 - TB6586FG: 1 pulse / electrical angle: 360°
 - TB6586AFG: 3 pulses / electrical angle: 360°

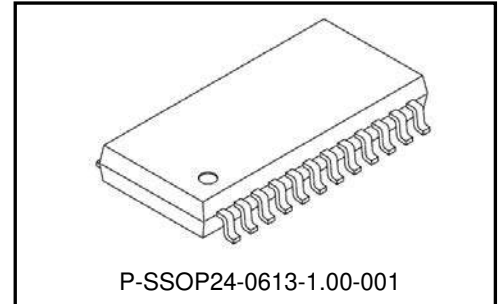

Weight: 0.36 g (typ.)

Pin Description

Pin No.	Symbol	Description
1	V _{SP}	Speed control input
2	HUP	U-phase Hall signal input (+) pin
3	HUM	U-phase Hall signal input (-) pin
4	HVP	V-phase Hall signal input (+) pin
5	HVM	V-phase Hall signal input (-) pin
6	HWP	W-phase Hall signal input (+) pin
7	HWM	W-phase Hall signal input (-) pin
8	V _{refout}	Outputs reference voltage signal (5 V / 35 mA)
9	LA	Lead angle setting signal input pin (30° / 4 bit)
10	GND	Ground pin
11	CW/CCW	Rotation direction signal input pin
12	OSC/C	Connect to capacitor for PWM oscillator
13	OSC/R	Connect to resistor for PWM oscillator
14	RS	Overcurrent protection (0.5 V)
15	RESET	Energization width toggle pin (Low: 150°, High; Reset, 6.35 V: 120°)
16	V _{CC}	Power supply
17	V _M	Input for output power
18	UL	U-phase output pin (Low side)
19	VL	V-phase output pin (Low side)
20	WL	W-phase output pin (Low side)
21	UH	U-phase output pin (High side)
22	VH	V-phase output pin (High side)
23	WH	W-phase output pin (High side)
24	FG	Output of number of pulses per revolution (FG: 1 pulse / electrical angle; AFG: 3 pulses / electrical angle)

Pin Layout

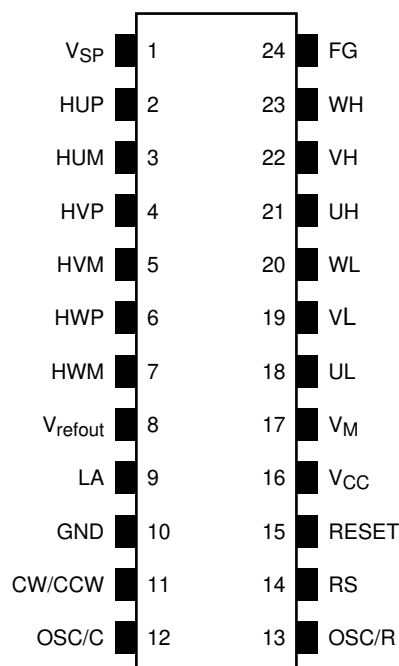

Input/Output Equivalent Circuits

The equivalent circuit diagrams may be simplified or some parts of them may be omitted for explanatory purposes.

Pin Description	Symbol	Input/Output Signal	Input/Output Internal Circuit
Positional signal input pin	HUP HUM HVP HVM HWP HWM	Analog/Digital Hysteresis ± 7.5 mV (typ.)	
Speed control signal input pin	VSP	Analog Input range 0 to 7 V	
Rotation direction signal input pin L: Forward (CW) H: Reverse (CCW)	CW/CCW	Digital L: 0.8 V (max) H: $V_{refout} - 1$ V (min) (Test input If CW/CCW = 6.35 V (typ.) or higher, the system resets) Hysteresis 150 mV (typ.)	
Reset input L: 150° turn-on mode H: Reset	RESET	Digital L: 0.8 V (max) H: $V_{refout} - 1$ V (min) If RESET = 6.35 V (typ.) or higher, then 120° energization drive is selected Hysteresis 150 mV (typ.) During a reset: Output OFF (all phases Low). The internal counter continues to operate.	
Lead angle setting signal input	LA	Analog Input range 0 to 5.0 V (V_{refout}) Electrical angle 0° to 28° can be divided into 16 by 4-bit data. Lead angle 0° : LA = 0 V (GND) Lead angle 28° : LA = 5 V (V_{refout})	

Pin Description	Symbol	Input/Output Signal	Input/Output Internal Circuit
Overcurrent protection signal input	RS	Analog Analog filter 0.5 μ s (typ.) If RS = 0.5 V (typ.) or higher, UH, VH and WH pin goes low (released at carrier cycle)	
Reference voltage signal output pin	V _{refout}	5.0 \pm 0.5 V (35 mA) 5.0 \pm 0.3 V (15 mA)	
Rotational frequency output	FG	Digital Push-pull output (\pm 2 mA (max)) TB6586FG: 1 pulse / electrical angle of 360° TB6586AFG: 3 pulses / electrical angle of 360°	
Energization signal output	UH UL VH VL WH WL	Push-pull output (\pm 3 mA (max))	

Block Diagram

In the block diagram, part of the functional blocks or constants may be omitted or simplified for explanatory purposes.

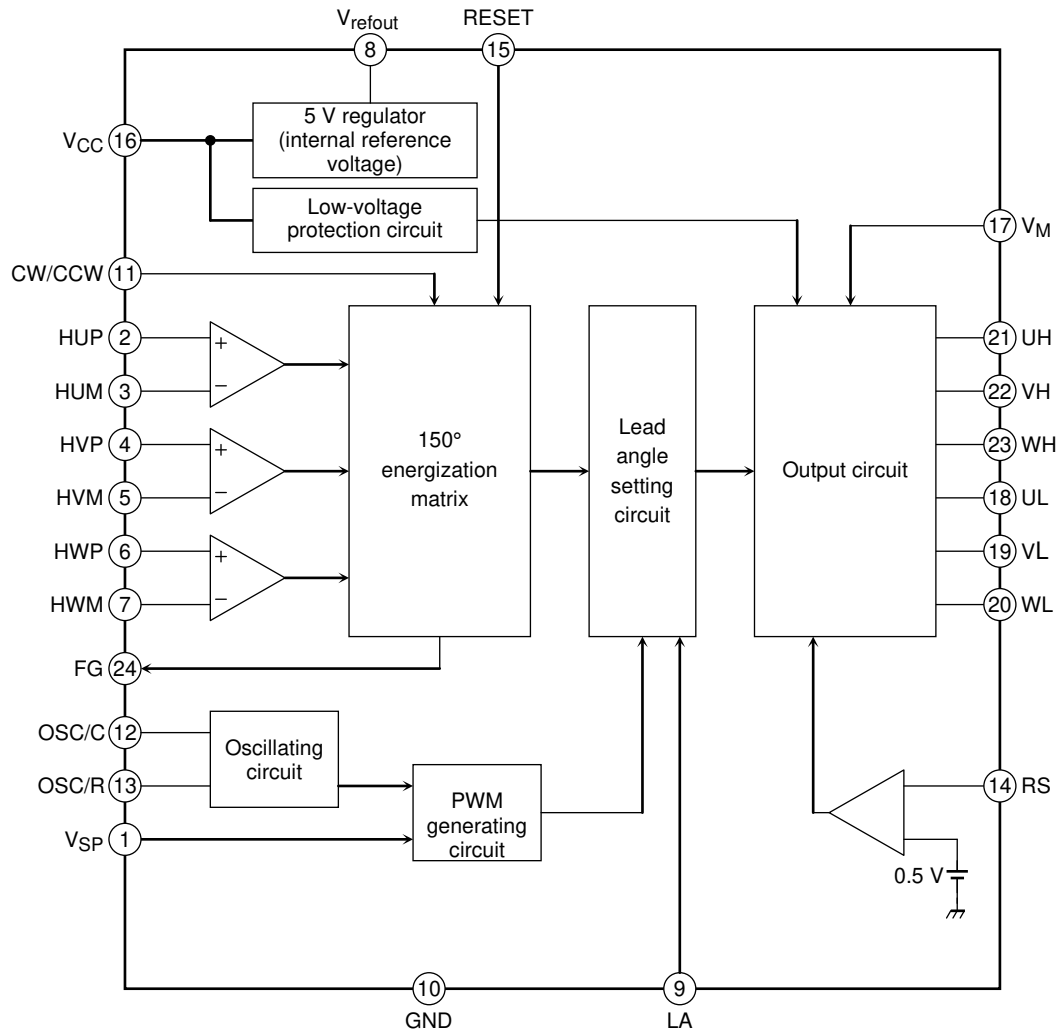

Absolute Maximum Ratings

Characteristic	Symbol	Rating	Unit
Supply voltage	V_{CC}	18	V
	V_M	18	
Input voltage	V_{IN1}	-0.3 to 8 (Note 1)	V
	V_{IN2}	-0.3 to 8.5 (Note 2)	
	V_{IN3}	-0.3 to $V_{refout} + 0.3$ (Note 3)	
Turn-on signal output current	I_{OUT}	3	mA
Power dissipation	P_D	0.8 (Note 4)	W
		1.0 (Note 5)	
Operating temperature	T_{opr}	-30 to 115	°C
Storage temperature	T_{stg}	-55 to 150	

Note 1: CW/CCW, RESET

Note 2: V_{SP}

Note 3: LA

Note 4: No heatsink

Note 5: When mounted on a PCB (50 × 50 × 1.6 mm, Cu 10%)

Operation Conditions ($T_a = 25^\circ\text{C}$)

Characteristic	Symbol	Min	Typ.	Max	Unit
Supply voltage	V_{CC}	6.5	15	16.5	V
	V_M	4.5	—	16.5	V
Oscillation frequency	F_{osc}	2	5	8	MHz

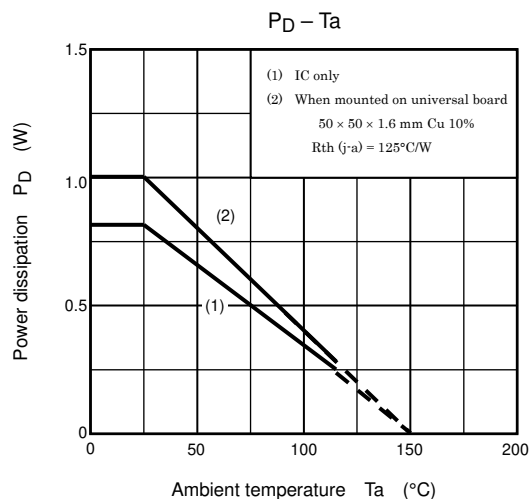

Electrical Characteristics (Unless otherwise specified Ta = 25°C, VCC = 15 V, VM = 5 V)

Characteristic		Symbol	Test Condition	Min	Typ.	Max	Unit	
Supply current		ICC	Vrefout = OPEN, OSC/C = 560 pF, OSC/R = 6.2 kΩ	—	5.5	10	mA	
Output current		IM	Drive output (UH, UL, VH, VL, WH, WL) = OPEN	—	0.5	1	mA	
Input current		IIN (LA)	VIN = 5 V LA	—	25	50	μA	
		IIN (SP)	VIN = 5 V VSP	—	35	70		
		IIN (RESET)	VIN = 5 V RESET	—	25	50		
		IIN (CW)	VIN = 5 V CW/CCW	—	25	50		
		IIN (RS)	VIN = 0 V RS	—	-25	-50		
Input voltage		VIN(CW/CCW)	RST	System reset	6.0	6.35	7.1	V
			High	CCW (Reverse)	Vrefout - 1	—	Vrefout	
			Low	CW (Forward)	0	—	0.8	
		VIN(RESET)	RST	120° energization	6.0	6.35	7.1	V
			High	Output off reset	2.2	—	Vrefout	
			Low	150° energization	0	—	0.8	
		VSP	H	PWM ON duty 95%	5.1	5.4	5.7	V
			M	Refresh → Start motor operation	1.8	2.1	2.4	
			L	Energization OFF → Refresh	0.7	1.0	1.3	
Hall element input	Input sensitivity	VS	Differential input	40	—	—	mVpp	
	Common mode	VW		1.5	—	3.5	V	
	Input hysteresis	VH (1)	(Note)	± 4.5	± 7.5	± 10.5	mV	
Input hysteresis voltage		VH (2)	RESET: Reset ↔ 120° energization (Note)	—	0.15	—	V	
		VH (3)	CW/CCW: CCW ↔ Reset (Note)	—	0.15	—		
Input delay		TRS	RS → Output OFF RS input : 0V / 2V	—	2.2	—	μs	
Output voltage		VOUT (15) - H	IOUT = 3 mA, VM = 15 V	13	14.2	—	V	
		VOUT (15) - L	IOUT = 3 mA, VM = 15 V	—	0.8	1.2		
		VOUT (5) - H	IOUT = 2 mA, VM = 5 V	4.0	4.2	—		
		VOUT (5) - L	IOUT = 2 mA, VM = 5 V	—	0.8	1.0		
		VFG (H)	IOUT = 2 mA FG	4	—	—		
		VFG (L)	IOUT = 2 mA FG	—	—	1.0		
		Vrefout1	IOUT = 15 mA Vrefout	4.7	5.0	5.3		
		Vrefout2	IOUT = 35 mA Vrefout	4.5	5.0	5.3		
Output leakage current		IL (H)	VOUT = 0 V	—	0	1	μA	
		IL (L)	VOUT = 15 V	—	0	1		
Electrical current detector		VRS	RS	0.46	0.5	0.54	V	
Lead angle correction		TLA (0)	LA = 0 V or open, Hall IN = 100 Hz	—	0	—	°	
		TLA (2.5)	LA = 2.5 V, Hall IN = 100 Hz	—	17	—		
		TLA (5)	LA = 5 V, Hall IN = 100 Hz	—	28	—		
VCC monitor		VCC (H)	Output operation start point	5.7	6.0	6.3	V	
		VCC (L)	No output operation point	4.7	5.0	5.3		
		VH (4)	Input hysteresis width (Note)	—	1.0	—		

Note: Pre-shipment testing is not performed.

Characteristic	Symbol	Test Condition	Min	Typ.	Max	Unit
PWM oscillator frequency (carrier frequency)	$F_C (20)$	OSC/C = 560 pF, OSC/R = 6.2 k Ω	18	20	22	kHz
	$F_C (18)$	OSC/C = 470 pF, OSC/R = 8.2 k Ω	16.2	18	19.8	
Output duty (max)	$T_{on} (max)$	OSC/C = 560 pF, OSC/R = 6.2 k Ω , $V_{SP} = 5.7$ V	92	95	98	%

Functional Description

1. Basic operation

At startup, the motor runs at 120° energization. When the position detection signal reaches a revolution count of $f_s = 5$ Hz or higher, the rotor position is extrapolated from the position detection signal and output is activated using the lead angle based on the LA signal.

Startup - 5 Hz: 120° energization $f_s = f_{osc} / (120 \times 2^5 \times 2^8)$

5 Hz or higher: 120° energization or 150° energization * Approximately 5 Hz if $f_{osc} = 5$ MHz.

*: At 5 Hz or higher, operation is performed in accordance with commands from RESET and LA pins. When the motor is running at 5 Hz or lower and in reverse (in accordance with the timing chart), it will be driven at 120° energization for a lead angle of 0°.

2. V_{SP} voltage command signal function

- (1) When voltage instruction is input at $V_{SP} \leq 1.0$ V:
Output is turned off (gate block protection).
- (2) When voltage instruction is input at 1.0 V < $V_{SP} \leq 2.1$ V (refresh operation):
The lower transistor is turned on at a regular (carrier) cycle. (ON duty: $T_{on} = 18/f_{osc}$)
- (3) When a voltage instruction is input at $V_{SP} > 2.1$ V:
The drive signal is output using the energization method configured using the RESET pin.

Note: At startup, to charge the upper transistor gate power supply, turn on the lower transistor for a fixed time with 1.0 V < $V_{SP} \leq 2.1$ V.

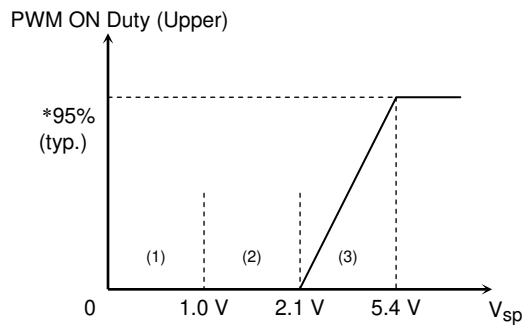

*: The maximum ON duty is $T_{on} = 95\%$ (typ.) when $V_{SP} = 5.4$ V (typ.).

Example: If $f_{osc} = 5$ MHz, then ON time = 48 μs (typ.) ($f_c = 19.8$ kHz)

If $f_{osc} = 4$ MHz, then ON time = 60 μs (typ.) ($f_c = 15.9$ kHz)

3. Function to stabilize the bootstrap voltage

The product is equipped with a bootstrap capacitor charging function that supports the output level of the bootstrap method.

- (1) If the VSP input voltage is 1.0 V < $V_{SP} \leq 2.1$ V, the ON signal based on the carrier cycle is output to the lower phase (UL, VL, WL) and the OFF signal (Low) is output to the upper phase (UH, VH, WH).

Output Waveform



Magnified view

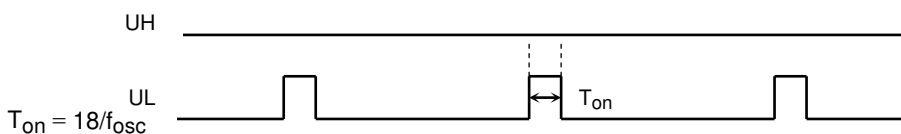

Example: $f_{osc} = 5$ MHz $T_{on} = 3.6$ μs

- (2) If the V_{SP} input voltage is $2.1\text{ V} < V_{SP}$ and the Hall signal is 5 Hz or less, the upper phase (UH, VH, WH) will perform 120° energization at a PWM that complies with the V_{SP} ; and the lower phase (UL, VL, WL) will operate at 120° energization, performing refresh operation based on the OFF timing. (The same drive is executed during reverse rotation as well.)

Example Output Waveform

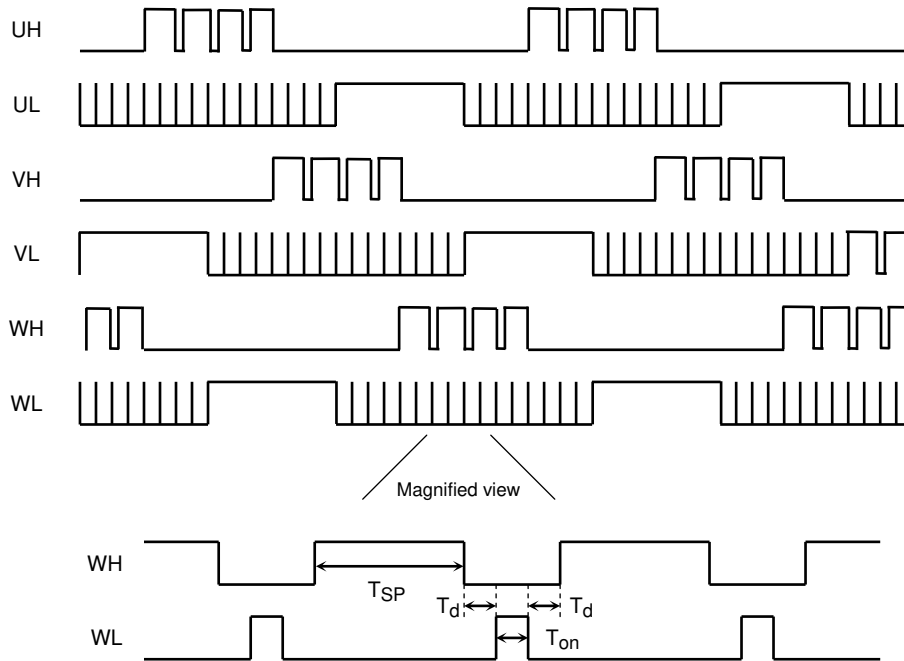

T_{SP} : Variable depending on the V_{SP} (the figure above being applicable when $V_{SP} = 5.4\text{ V}$ (typ.));
 $T_{on} = 18/f_{osc}$; $T_d = 18/f_{osc}$

*: The lead angle correction (LA pin) function does not operate when the Hall signal is 5 Hz or less.
 The lead angle correction function also does not operate when in a reverse detection state.

4. Correcting the lead angle

The lead angle can be corrected in the turn-on signal range from 0 to 28° in relation to the induced voltage.
 Analog input from the LA pin (0 V to 4.3 V divided by 16):

- 0 V = 0°
- 4.3 V or higher = 28°

Sample Evaluation Results

Steps	LA (V)	Lead Angle ($^\circ$)
1	0.00	0.00
2	0.05	1.93
3	0.28	3.79
4	0.59	5.65
5	0.89	7.54
6	1.21	9.43
7	1.52	11.29
8	1.83	13.15
9	2.14	15.08
10	2.45	16.87
11	2.75	18.73
12	3.06	20.66
13	3.37	22.55
14	3.68	24.37
15	3.99	26.16
16	4.30	28.09

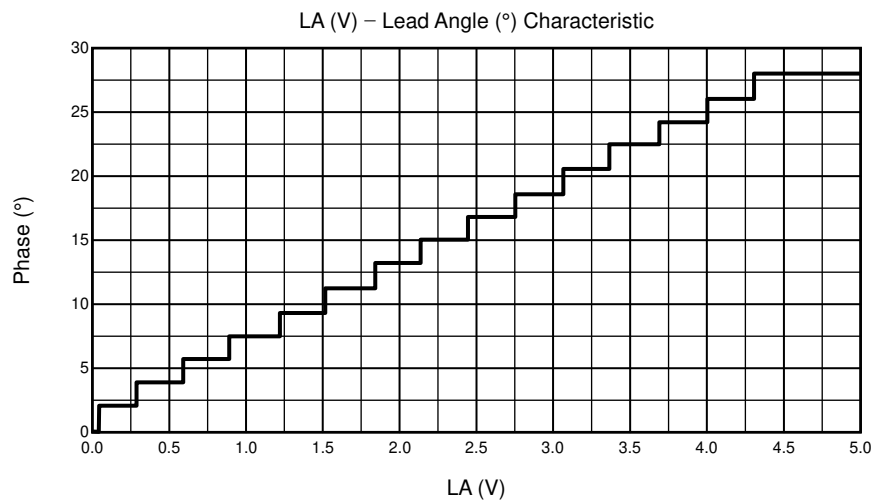

5. Setting the carrier frequency

This function involves setting the triangular wave frequency (carrier frequency) necessary for generating PWM signals.

Carrier frequency: $f_c = f_{osc}/252$ (Hz) f_{osc} = reference clock (CR oscillation)

Example: If $f_{osc} = 5$ MHz, then $f_c = 19.8$ kHz
 If $f_{osc} = 4$ MHz, then $f_c = 15.9$ kHz

6. Position detection pin

The common-mode voltage range is $V_W = 1.5$ to 3.5 V. The input hysteresis is $V_H = 7.5$ mV (typ.).

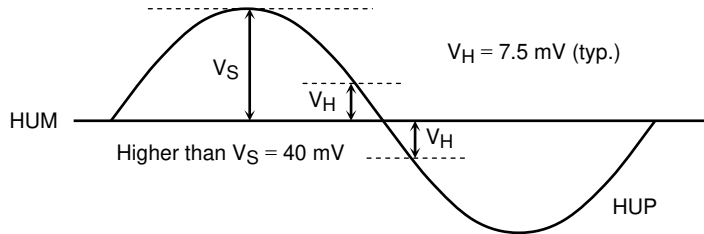

7. Revolution pulse output pin (the difference between TB6586FG and TB6586AFG)

This pin outputs the revolution pulses based on the Hall signal. The TB6586FG outputs one (1) pulse / electrical angle and the TB6586AFG outputs three (3) pulses / electrical angle. In the case of the TB6586FG, this pulse is generated via the U phase Hall signal. For a Hall element, the pulse is converted to digital and then output. For a Hall IC, it is output in the equivalent waveform. In the case of the TB6586AFG, the up-down edges of the U, V and W phase (respectively) are combined and then generated.

Example: Number of FG pulses for an 8-pole motor:
 • TB6586FG: 4 pulses per revolution (4 ppr)
 • TB6586AFG: 12 pulses per revolution (12 ppr)

FG Signal Timing Chart

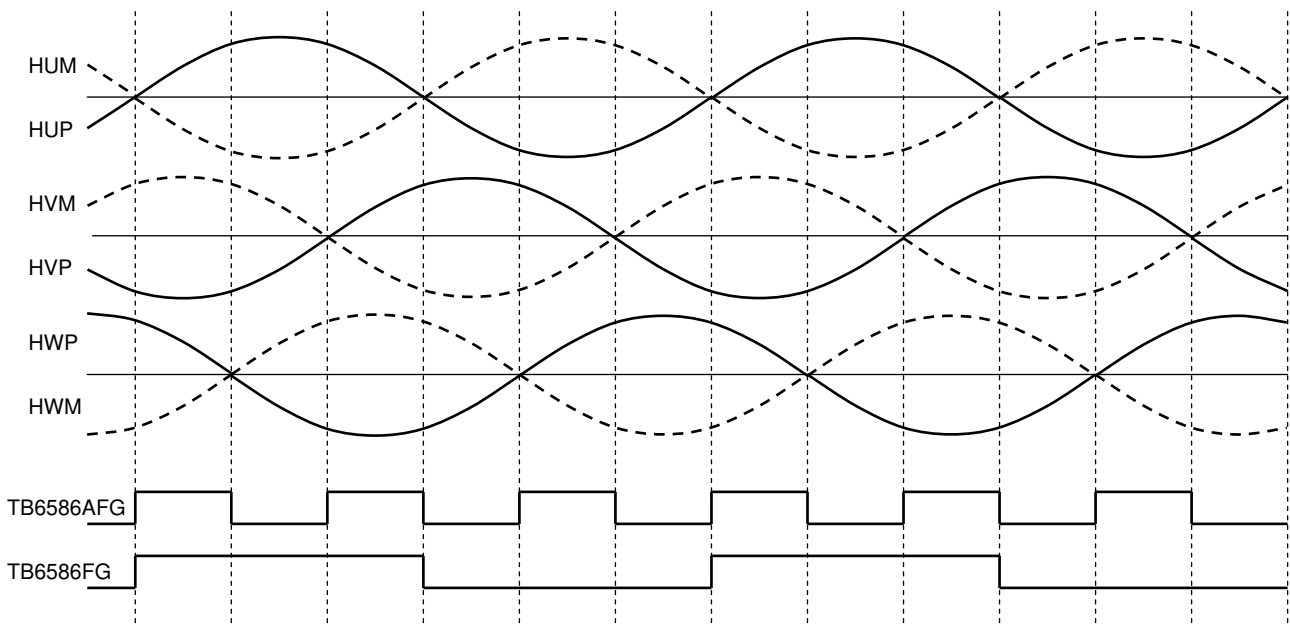

8. Protecting input pin

(1) Overcurrent protection (Pin RS)

When the DC link current exceeds the internal reference voltage, this pin performs gate block protection. Overcurrent protection is restored for each carrier cycle.

The pin is equipped with a filter (analog filter = 0.5 μ s (typ.)) that prevents malfunctioning due to external noise.

(2) Position detection signal error protection

When the position detection signals are either all High, Low or Open, all the output is turned OFF (all phases Low). Anything else results in a restart.

(3) Low power voltage protection (VCC power monitor)

If the operation voltage range is exceeded when the power is being turned on or off, all the output is turned Low to prevent short circuit damage to the power element. Also, if 2.1 V or higher is input via the VSP pin, and if the motor is not rotating (Hall signal = 5 Hz or less), then normal drive is restored after a refresh operation (1.5 ms (typ.)) is performed. However, operations cannot be guaranteed during a power restoration as the circuitry will be unstable when the power is turned on.

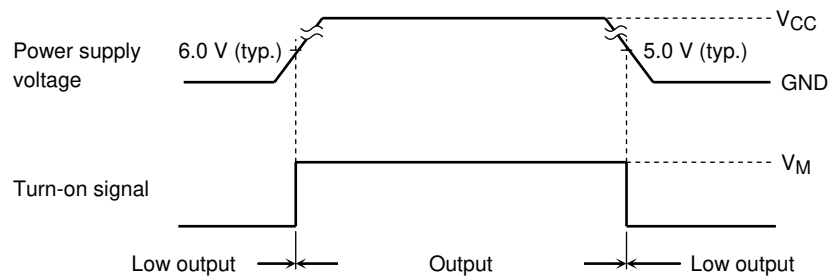

(4) Output pulse width restriction

To prevent damage to the output driver (externally attached), the drive output signals (UH, VH, WH, UL, VL, WL) are restricted from being output at a pulse width of 1 μ s or less.

(5) Reset circuit

When 2.2 V (min) or more is input to the RESET pin, a reset will be performed with all output phases being turned off (i.e., all phases Low). Output is also turned off if 6.35 V (typ.) or more is supplied to the CW/CCW pin. However, do not use this method as the restoration obtained from it is unstable.

- RESET pin: Output off reset

All output phases are turned Low and the externally connected power element is stopped. When 0.8 V (max) or less is input, the power is restored. During the restoration, if 2.1 V or more is not input to the VSP pin, and if the motor is not rotating (Hall signal = 5 Hz or less), a refresh operation will be performed (1.5 ms (typ.)). Normal drive will then be restored.

During the reset, the internal counter continues to operate and the FG signal continues to be output.

- CW/CCW pin: System reset

All output phases are turned Low and the externally connected power element is stopped.

Restoration takes place at an input of 6.35 V (typ.). However, operation after this kind of system reset is unstable.

TB6586FG: During a system reset, the FG signal is output in compliance with the U-phase Hall signal.

TB6586AFG: The FG signal is not output during a system reset.

Timing Chart (CW/CCW = Low, LA = GND)

(The FG signal shown here is for the TB6586AFG.)

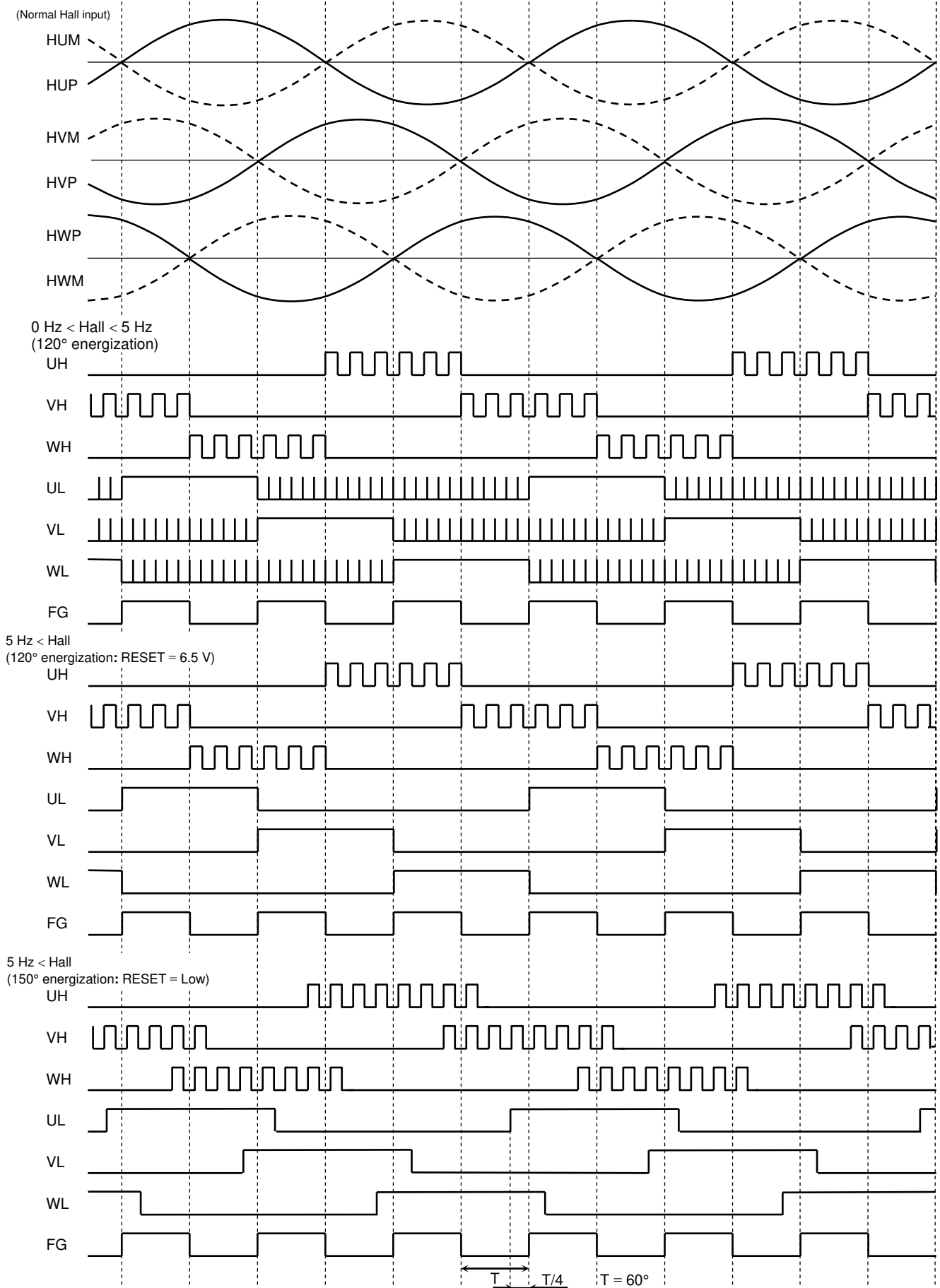

*: When the Hall signal is 5 Hz or higher, the lead angle function operates in accordance with the LA pin. signal.

Timing Chart (CW/CCW = High, LA = GND)

(The FG signal shown here is for the TB6586AFG.)

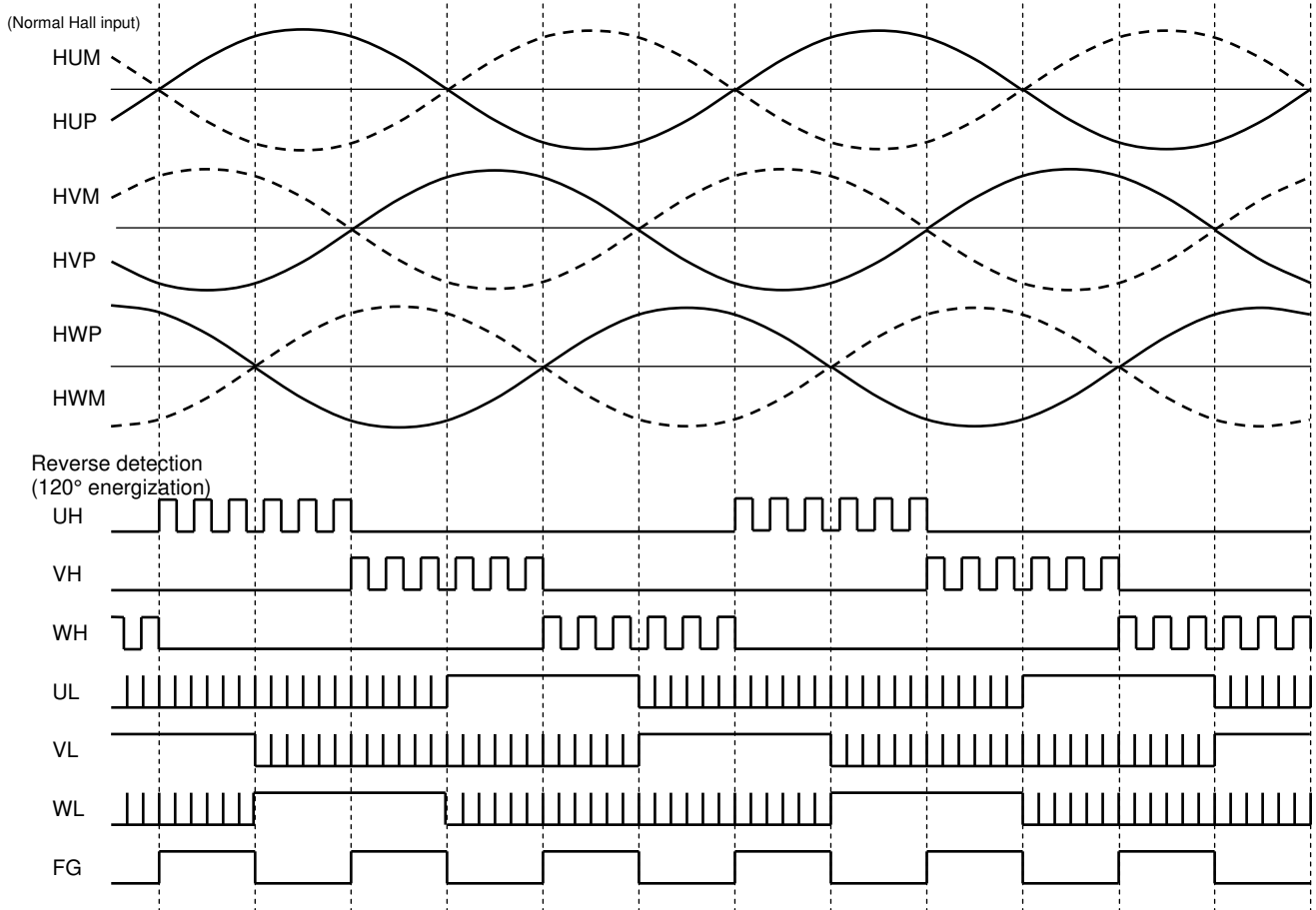

*: When CW/CCW = High and a normal Hall signal is input, it runs at 120° energization for a lead angle of 0° (reverse rotation).

Timing Chart (CW/CCW = High, LA = GND)

(The FG signal shown here is for the TB6586AFG.)

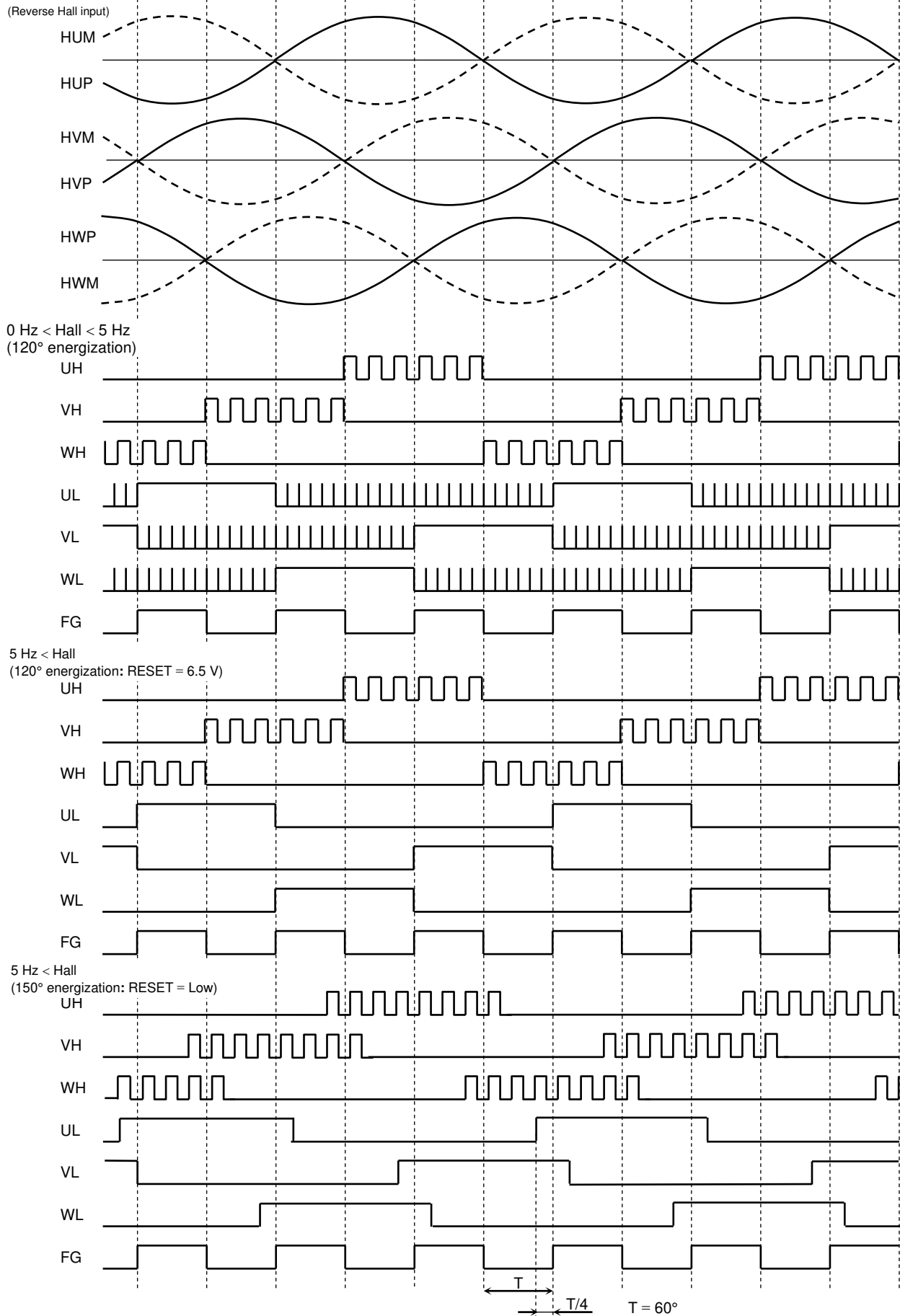

*: When the Hall signal is 5 Hz or higher, the lead angle function operates in accordance with the LA pin signal.

Timing Chart (CW/CCW = Low, LA = GND)

(The FG signal shown here is for the TB6586AFG.)

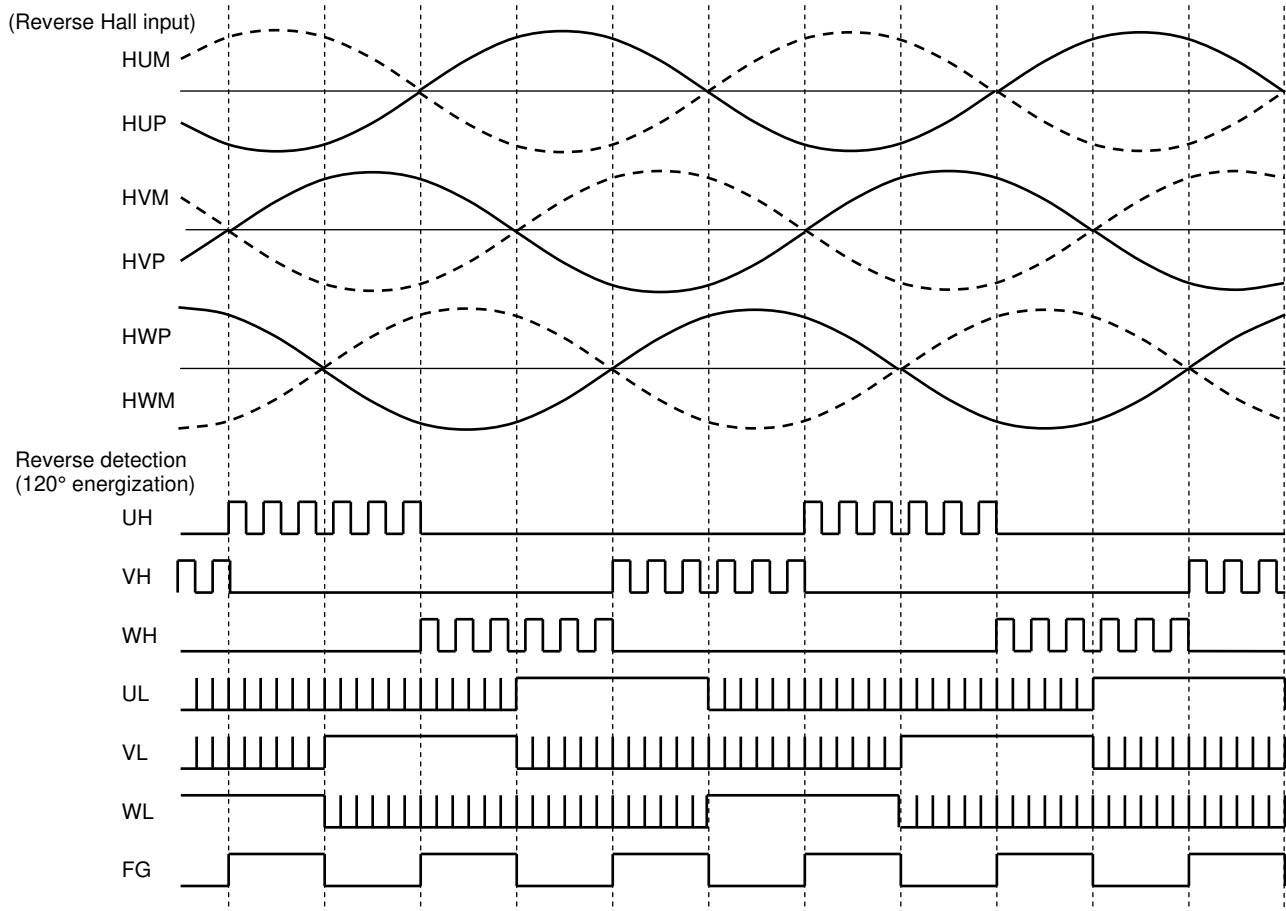

*: When CW/CCW = Low and a reverse Hall signal is input, the motor runs at 120° energization for a lead angle of 0° (reverse rotation)

Package Dimensions

P-SSOP24-0613-1.00-001

"Unit:mm"

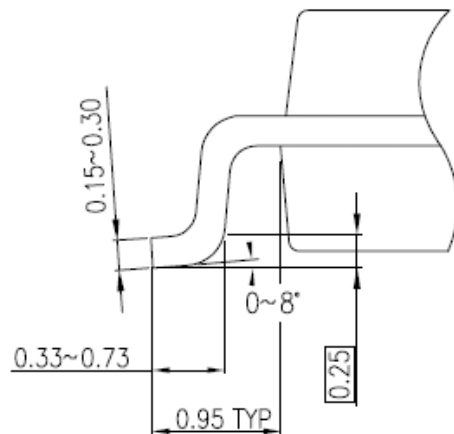
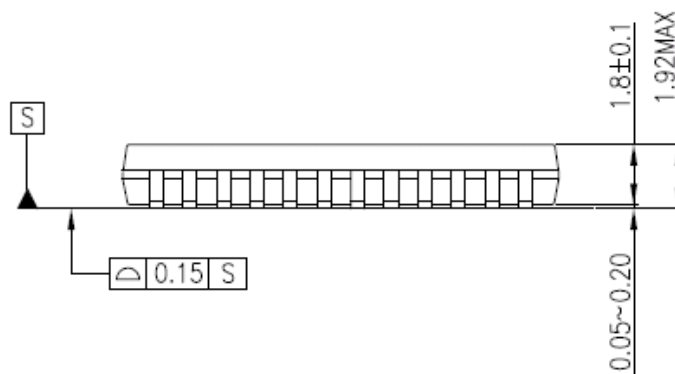
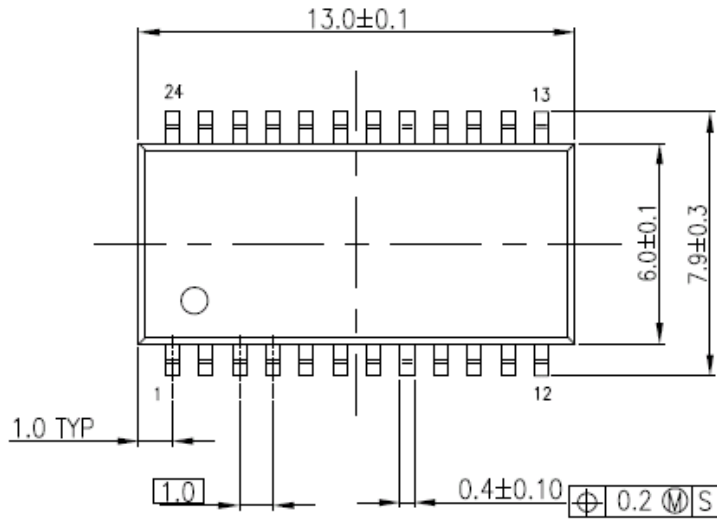

Weight: 0.36 g (typ.)

Notes on Contents

1. Block Diagrams

Some of the functional blocks, circuits, or constants in the block diagram may be omitted or simplified for explanatory purposes.

2. Equivalent Circuits

The equivalent circuit diagrams may be simplified or some parts of them may be omitted for explanatory purposes.

3. Timing Charts

Timing charts may be simplified for explanatory purposes.

4. Application Circuits

The application circuits shown in this document are provided for reference purposes only. Thorough evaluation is required, especially at the mass production design stage.

Toshiba does not grant any license to any industrial property rights by providing these examples of application circuits.

IC Usage Considerations

Notes on handling of ICs

[1] The absolute maximum ratings of a semiconductor device are a set of ratings that must not be exceeded, even for a moment. Do not exceed any of these ratings.

Exceeding the rating(s) may cause the device breakdown, damage or deterioration, and may result injury by explosion or combustion.

[2] Do not insert devices in the wrong orientation or incorrectly.

Make sure that the positive and negative terminals of power supplies are connected properly.

Otherwise, the current or power consumption may exceed the absolute maximum rating, and exceeding the rating(s) may cause the device breakdown, damage or deterioration, and may result injury by explosion or combustion.

In addition, do not use any device that is applied the current with inserting in the wrong orientation or incorrectly even just one time.

Points to remember on handling of ICs

Heat Radiation Design

In using an IC with large current flow such as power amp, regulator or driver, please design the device so that heat is appropriately radiated, not to exceed the specified junction temperature (T_j) at any time and condition. These ICs generate heat even during normal use. An inadequate IC heat radiation design can lead to decrease in IC life, deterioration of IC characteristics or IC breakdown.

In addition, please design the device taking into consideration the effect of IC heat radiation with peripheral components.

RESTRICTIONS ON PRODUCT USE

- Toshiba Corporation, and its subsidiaries and affiliates (collectively "TOSHIBA"), reserve the right to make changes to the information in this document, and related hardware, software and systems (collectively "Product") without notice.
- This document and any information herein may not be reproduced without prior written permission from TOSHIBA. Even with TOSHIBA's written permission, reproduction is permissible only if reproduction is without alteration/omission.
- Though TOSHIBA works continually to improve Product's quality and reliability, Product can malfunction or fail. Customers are responsible for complying with safety standards and for providing adequate designs and safeguards for their hardware, software and systems which minimize risk and avoid situations in which a malfunction or failure of Product could cause loss of human life, bodily injury or damage to property, including data loss or corruption. Before customers use the Product, create designs including the Product, or incorporate the Product into their own applications, customers must also refer to and comply with (a) the latest versions of all relevant TOSHIBA information, including without limitation, this document, the specifications, the data sheets and application notes for Product and the precautions and conditions set forth in the "TOSHIBA Semiconductor Reliability Handbook" and (b) the instructions for the application with which the Product will be used with or for. Customers are solely responsible for all aspects of their own product design or applications, including but not limited to (a) determining the appropriateness of the use of this Product in such design or applications; (b) evaluating and determining the applicability of any information contained in this document, or in charts, diagrams, programs, algorithms, sample application circuits, or any other referenced documents; and (c) validating all operating parameters for such designs and applications. **TOSHIBA ASSUMES NO LIABILITY FOR CUSTOMERS' PRODUCT DESIGN OR APPLICATIONS.**
- **PRODUCT IS NEITHER INTENDED NOR WARRANTED FOR USE IN EQUIPMENTS OR SYSTEMS THAT REQUIRE EXTRAORDINARILY HIGH LEVELS OF QUALITY AND/OR RELIABILITY, AND/OR A MALFUNCTION OR FAILURE OF WHICH MAY CAUSE LOSS OF HUMAN LIFE, BODILY INJURY, SERIOUS PROPERTY DAMAGE AND/OR SERIOUS PUBLIC IMPACT ("UNINTENDED USE").** Except for specific applications as expressly stated in this document, Unintended Use includes, without limitation, equipment used in nuclear facilities, equipment used in the aerospace industry, medical equipment, equipment used for automobiles, trains, ships and other transportation, traffic signaling equipment, equipment used to control combustions or explosions, safety devices, elevators and escalators, devices related to electric power, and equipment used in finance-related fields. **IF YOU USE PRODUCT FOR UNINTENDED USE, TOSHIBA ASSUMES NO LIABILITY FOR PRODUCT.** For details, please contact your TOSHIBA sales representative.
- Do not disassemble, analyze, reverse-engineer, alter, modify, translate or copy Product, whether in whole or in part.
- Product shall not be used for or incorporated into any products or systems whose manufacture, use, or sale is prohibited under any applicable laws or regulations.
- The information contained herein is presented only as guidance for Product use. No responsibility is assumed by TOSHIBA for any infringement of patents or any other intellectual property rights of third parties that may result from the use of Product. No license to any intellectual property right is granted by this document, whether express or implied, by estoppel or otherwise.
- **ABSENT A WRITTEN SIGNED AGREEMENT, EXCEPT AS PROVIDED IN THE RELEVANT TERMS AND CONDITIONS OF SALE FOR PRODUCT, AND TO THE MAXIMUM EXTENT ALLOWABLE BY LAW, TOSHIBA (1) ASSUMES NO LIABILITY WHATSOEVER, INCLUDING WITHOUT LIMITATION, INDIRECT, CONSEQUENTIAL, SPECIAL, OR INCIDENTAL DAMAGES OR LOSS, INCLUDING WITHOUT LIMITATION, LOSS OF PROFITS, LOSS OF OPPORTUNITIES, BUSINESS INTERRUPTION AND LOSS OF DATA, AND (2) DISCLAIMS ANY AND ALL EXPRESS OR IMPLIED WARRANTIES AND CONDITIONS RELATED TO SALE, USE OF PRODUCT, OR INFORMATION, INCLUDING WARRANTIES OR CONDITIONS OF MERCHANTABILITY, FITNESS FOR A PARTICULAR PURPOSE, ACCURACY OF INFORMATION, OR NONINFRINGEMENT.**
- Do not use or otherwise make available Product or related software or technology for any military purposes, including without limitation, for the design, development, use, stockpiling or manufacturing of nuclear, chemical, or biological weapons or missile technology products (mass destruction weapons). Product and related software and technology may be controlled under the applicable export laws and regulations including, without limitation, the Japanese Foreign Exchange and Foreign Trade Law and the U.S. Export Administration Regulations. Export and re-export of Product or related software or technology are strictly prohibited except in compliance with all applicable export laws and regulations.
- Please contact your TOSHIBA sales representative for details as to environmental matters such as the RoHS compatibility of Product. Please use Product in compliance with all applicable laws and regulations that regulate the inclusion or use of controlled substances, including without limitation, the EU RoHS Directive. **TOSHIBA ASSUMES NO LIABILITY FOR DAMAGES OR LOSSES OCCURRING AS A RESULT OF NONCOMPLIANCE WITH APPLICABLE LAWS AND REGULATIONS.**