

PART NUMBER	REV	FIRST USED	POWER UNIT	FEED TYPE	DESCRIPTION
1852804-1	A	122500-1	LEADMAKER	POST FEED	CUTS CARRIER
1852804-2	A	565435-5	BENCH MODEL K	PRE FEED	CUTS CARRIER
1852804-3	A	354500-1	BENCH MODEL G	PRE FEED	CUTS CARRIER
1852804-6	A	122500-1	LEADMAKER	POST FEED	CONTINUOUS CARRIER
7-1852804-7	A	-	-	-	SPARE PARTS

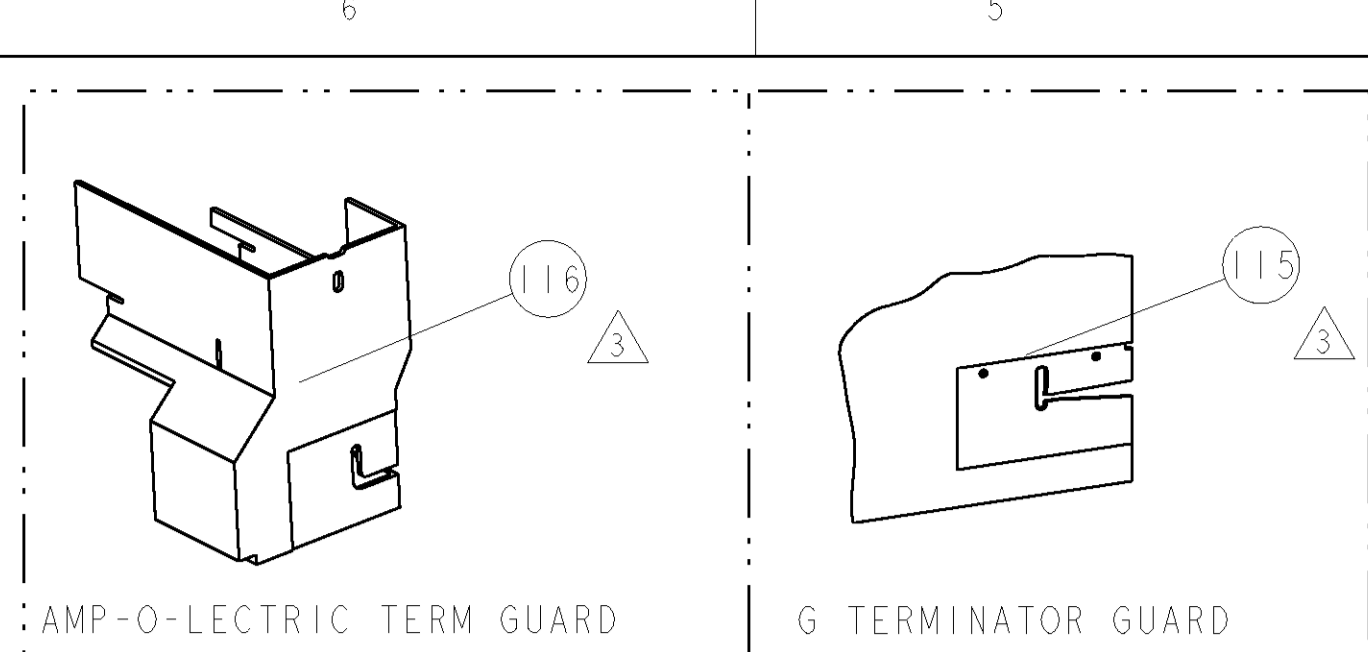

TERMINAL NAME: TERMINAL		TE CRIMP SPECS	
TE PN	MANUF PN		
1949861	26780.201.184		
-	-	PAD LTR	CRIMP HEIGHT
-	-	A	1.47mm±.05/- .05 [ .058±.002/- .002 ]
-	-	B	1.32mm±.05/- .05 [ .052±.002/- .002 ]
-	-	C	-
-	-	D	-
SEAL PN	WIRE	SIZE	TYPE
286867	15324973	2.03mm [ .080 ]	F
-	-	INSUL	3.56mm [ .140 ]
WIRE STRIP LENGTH	TERM APPL SPEC	FEED	APPLICATOR INSTRUCTIONS
4.69-5.07	NONE	11.48	408-8040
			SET UP GAGE
			458637-1

LOC	DIST	REVISIONS					
A	66	F	LTR	DESCRIPTION	DATE	OWN	APPR
		A		RELEASED	20JAN2009	RK	TE

- △ RECOMMENDED SPARE PARTS
- △ GREASE LIGHTLY
- △ GUARD MUST BE IN PLACE WHEN OPERATING APPLICATOR IN A BENCH MACHINE
- △ APPLY TORQ-SEAL IN ALLEN SOCKET TO FILL HOLE AFTER FLAT HD HAS BEEN ADJUSTED TO CORRECT HEIGHT AT QUALIFICATION. APPLY PN 1-23419-5 LOC-TITE TO THREADS.

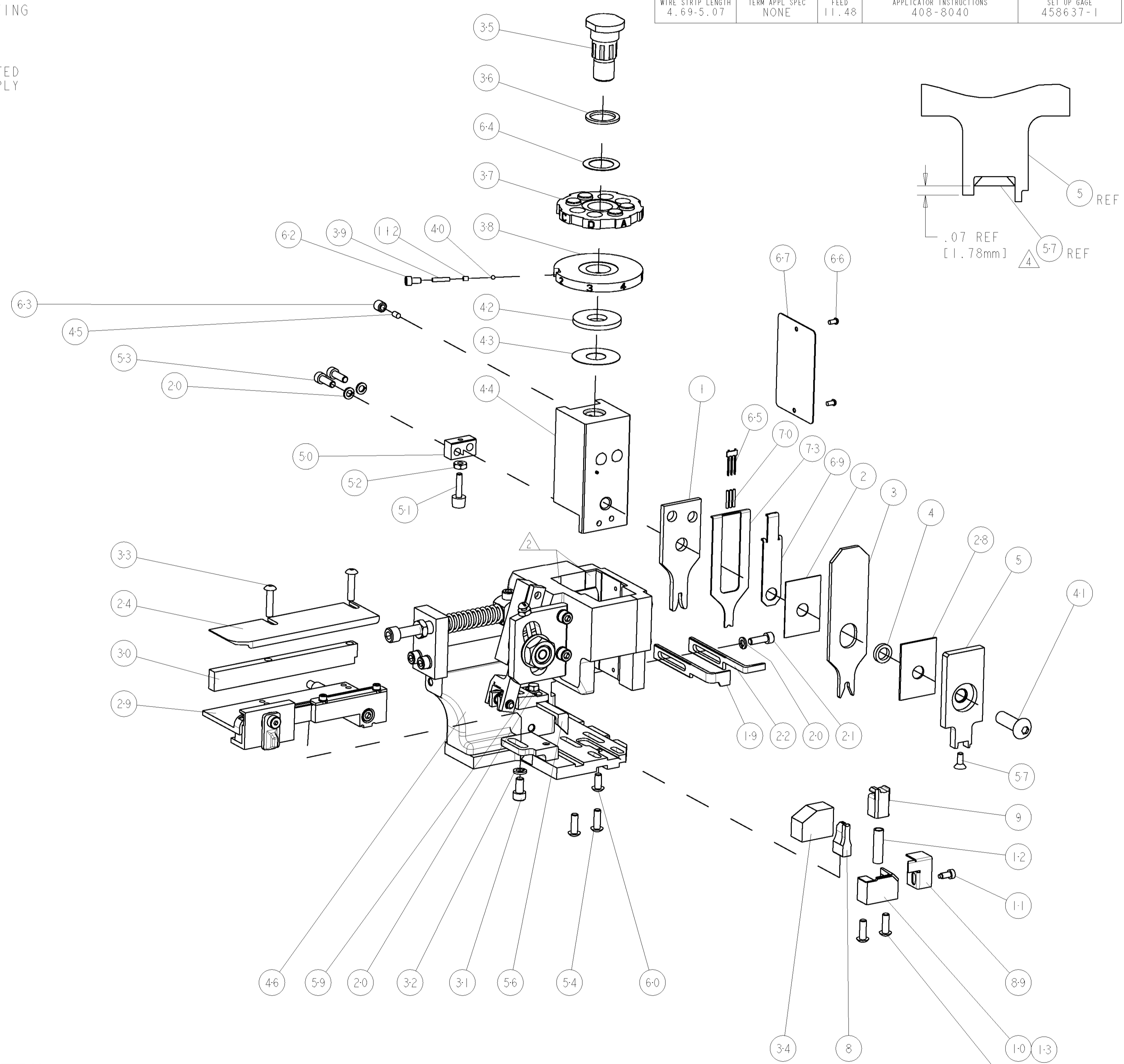
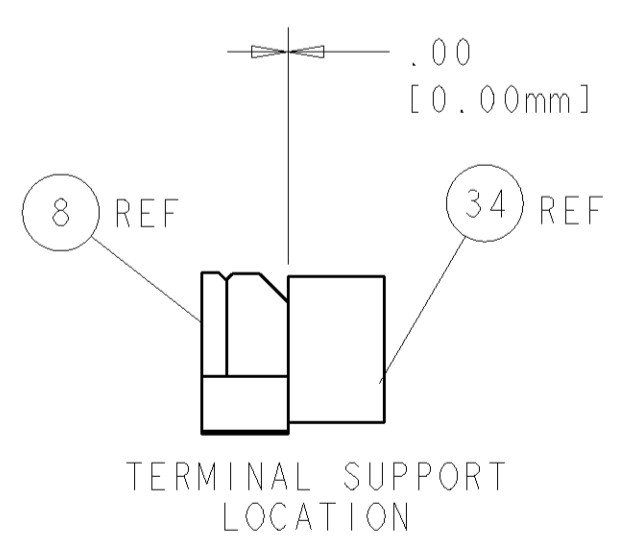
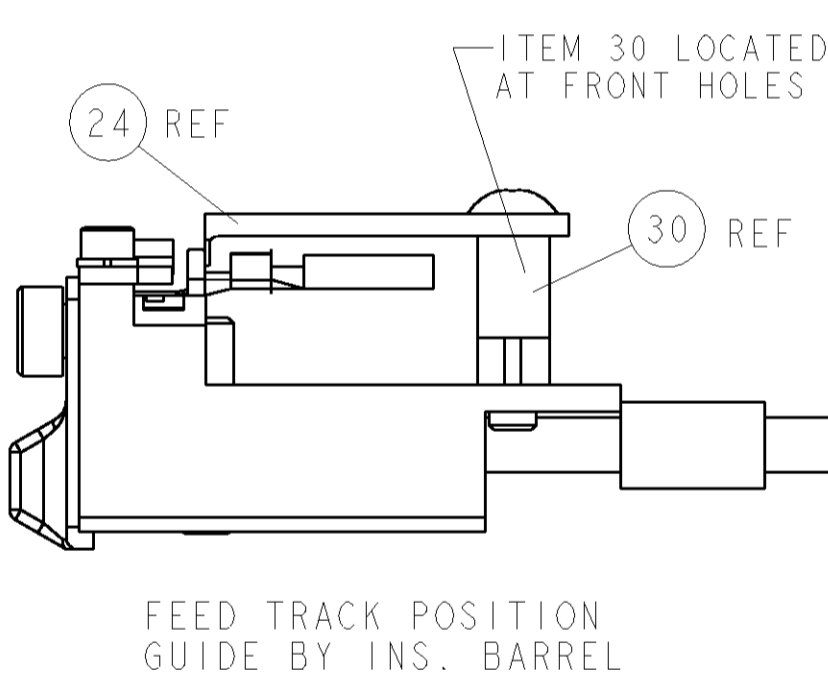
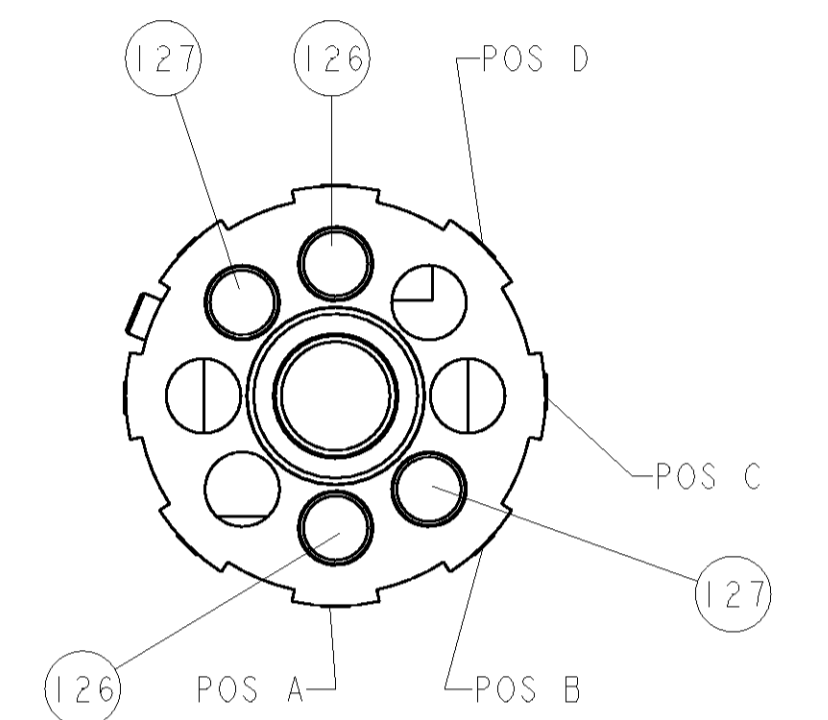

QTY	REV	REV	REV	REV	REV	PART NO	DESCRIPTION	ITEM NO
-	2	2	2	2	-	2-354779-4	PIN, WIRE DISC, .3110	127
-	2	2	2	2	-	1-354779-0	PIN, WIRE DISC, .3040	126
-	-	-	REF	-	..	455749-1	GUARD WINDOW	116
-	-	-	REF	-	..	679532-1	INSERT, GUARD	115
-	1	1	1	1	-	690603-1	SPRING ASSIST AMP-O-MATOR APPLICATOR	112
-	1	1	1	1	-	1-21002-7	SCR, BTN SKT HD CAP 6-32 X .375	91
-	1	1	1	1	-	318563-1	GUARD, FRONT CHIP	89
-	1	1	1	1	-	1490525-2	DEPRESSOR, WIRE	73
-	1	1	1	1	-	4088040	SF APPL INST 408-8040	72
-	1	1	1	1	-	217238-1	GENERAL INSTRUCTION PKG	71
-	3	3	3	3	-	2-23147-2	SPRING, COMPRESSION	70
-	1	1	1	1	-	1490524-2	DEPRESSOR, SPACER	69
-	1	1	1	1	-	461264-1	PLATE, IDENTIFICATION	67
-	2	2	2	2	-	21017-2	SCREW, DRIVE	66
-	1	1	1	1	-	1424350-1	HOLDER, PIN, WIRED	65
-	1	1	1	1	-	986950-1	WASHER, FLAT PRECISION	64
-	1	1	1	1	-	21009-2	SCR, SET, SELF LOCKING 1/4-20 X .250	63
-	1	1	1	1	-	23030-1	SCR, SKT HD CAP 6-32 X .25	62
-	1	1	1	1	-	22733-8	SCR, BHSC, SELF-LOCKING, 8-32 X .375	60
-	1	1	1	1	-	2-22603-0	SCR, HEX HD CAP 8-32 X .312	59
-	1	1	1	1	-	1-21003-9	SCR, FLT SKT HD CAP 6-32 X .375	57
-	1	1	1	1	-	458537-2	PAWL, FEED	56
-	4	4	4	4	-	2-21002-2	SCR, BTN SKT HD CAP 8-32 X .500	54
-	2	2	2	2	-	2-21000-7	SCR, SKT HD CAP 8-32 X .500	53
-	1	1	1	1	-	21018-5	NUT, HEX, REG 6-32	52
-	1	1	1	1	-	811242-2	BUMPER, HOLD DOWN	51
-	1	1	1	1	-	690753-1	SPACER, TONKER	50
-	-	-	-	-	..	690602-6	CAM, PRE FEED, 1 5/8	49
-	-	-	-	-	..	690602-5	CAM, PRE FEED, 1 1/8	48
-	1	-	-	1	-	690501-4	CAM, POST-FEED 1 5/8	47
-	1	1	1	1	-	459456-1	APPL. BASIC SUB ASSY (SIDE WISE MOCA)	46
-	1	1	1	1	-	690191-1	PLUG, NYLON	45
-	1	1	1	1	-	455673-1	RAM, SIDE FEED	44
-	1	1	1	1	-	690125-1	SHIM SUB-ASSY	43
-	1	1	1	1	-	690124-1	WASHER, RAM (.115)	42
-	1	1	1	1	-	7-21002-9	SCR, BTN SKT HD CAP 5/16-24 X 1.00	41
-	1	1	1	1	-	23241-6	BALL, STEEL	40
-	1	1	1	1	-	690170-1	SPRING, COMPRESSION	39
-	1	1	1	1	-	1-690142-0	DISC, INSULATION	38
-	1	1	1	1	-	354777-1	WIRE DISC, ASSEMBLY	37
-	1	1	1	1	-	22480-5	SPRING, COMPRESSION	36
-	1	1	1	1	-	690212-1	POST, RAM	35
-	1	1	1	1	-	690786-3	TERMINAL SUPPORT	34
-	2	2	2	2	-	2-21002-4	SCR, BTN SKT HD CAP 8-32 X .750	33
-	1	1	1	1	-	21024-5	WASHER, SPRG LOCK, REG NO 10	32
-	1	1	1	1	-	3-21000-4	SCR, SKT HD CAP 10-32 X .375	31
-	1	1	1	1	-	1320908-8	SPACER, STRIP GUIDE	30
-	1	1	1	1	-	1633091-3	ASSEMBLY, STRIP GUIDE	29
-	1	1	1	1	-	1-455888-0	SPACER, CRIMPER	28
-	1	1	1	1	-	1320928-1	PLATE, STRIP GUIDE	24
-	1	1	1	1	-	690472-2	STRIPPER	22
-	1	1	1	1	-	2-21000-7	SCR, SKT HD CAP 8-32 X .500	21
-	4	4	4	4	-	21024-4	WASHER, SPRG LOCK, REG NO 8	20
-	-	-	-	-	..	691353-2	STRIPPER	19
-	-	-	-	-	..	679625-2	SHEAR HOLDER, FRONT (NO CUT)	13
-	1	1	1	1	-	3-22280-3	SPRING, COMPRESSION	12
-	1	1	1	1	-	690461-2	STOP, SHEAR	11
-	-	-	-	-	..	1-690459-0	SHEAR HOLDER, FRONT	10
-	1	1	1	1	-	318707-2	FLOATING SHEAR, FRONT	9
-	1	1	1	1	-	4-1633109-4	ANVIL, COMBINATION .080	8
-	-	-	-	-	..	-	-	7
-	-	-	-	-	..	-	-	6
-	1	1	1	1	-	318701-1	DEPRESSOR, SHEAR	5
-	1	1	1	1	-	238011-4	BLOCK, CRIMPER SPACER	4
-	1	1	1	1	-	1633710-7	CRIMPER, INSULATION 0	3
-	1	1	1	1	-	455888-4	SPACER, CRIMPER	2
-	1	1	1	1	-	2-456405-4	CRIMPER, WIRE PREMIUM	1

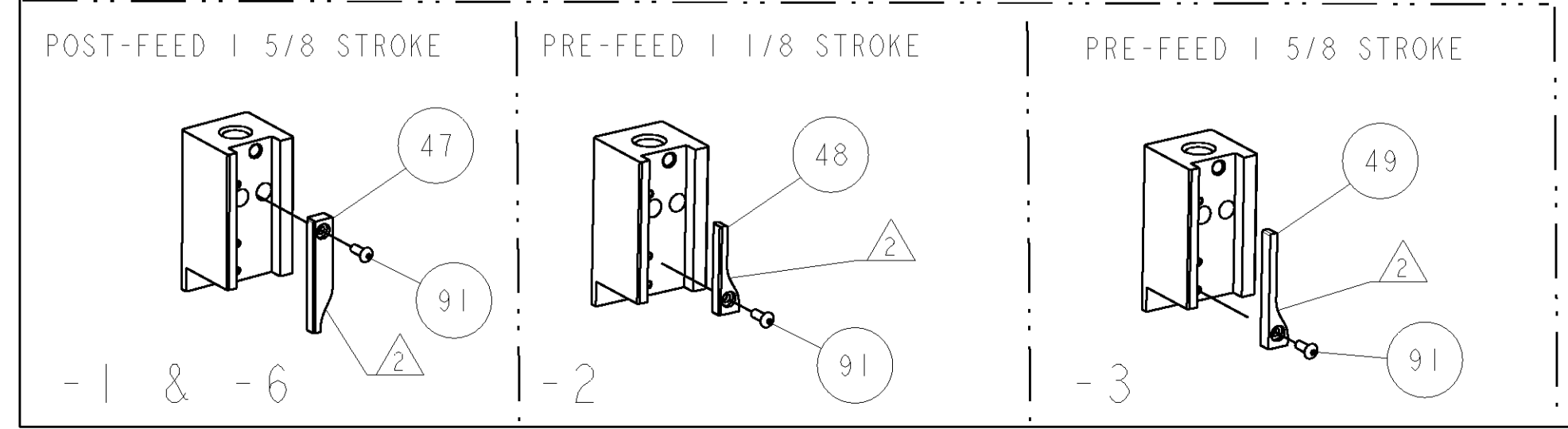

DIMENSIONS:		TOLERANCES UNLESS OTHERWISE SPECIFIED:	
INCHES	0 PLC ±.01	1 PLC ±.01	2 PLC ±.01
	3 PLC ±.001	4 PLC ±.001	ANGLES ±.0001

DATE	19DEC2008	DRAWN	C. CHEN
CHKD	20JAN2009	APPROV	T. ELBIN
APPROV	20JAN2009	NAME	N. DELING
PRODUCT SPEC		APPLICATION SPEC	
MATERIAL		FINISH	
WEIGHT		SCALE	
CUSTOMER DRAWING		SHEET 1 OF 1	

DIMENSIONS: INCHES  
 TOLERANCES UNLESS OTHERWISE SPECIFIED:  
 0 PLC ±.01  
 1 PLC ±.01  
 2 PLC ±.01  
 3 PLC ±.001  
 4 PLC ±.001  
 ANGLES ±.0001

DATE: 19DEC2008  
 DRAWN: C. CHEN  
 CHKD: T. ELBIN  
 APPROV: N. DELING (20JAN2009)  
 PRODUCT SPEC: -  
 APPLICATION SPEC: -  
 MATERIAL: -  
 FINISH: -  
 WEIGHT: -  
 SCALE: 3:5  
 SHEET: 1 OF 1  
 REV: A

CUSTOMER VIEWABLE ASSEMBLY