

CURMT101-HF Thru. CURMT107-HF

Reverse Voltage: 50 to 1000 Volts

Forward Current: 1.0 Amp

RoHS Device

Halogen Free

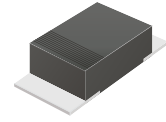

Features

- Excellent power dissipation offers better reverse leakage current and thermal resistance.
- Low profile package is 40% thinner than standards SOD-123.
- Tiny plastic SMD package.
- High current capability.
- Ultrafast recovery time for high efficiency.
- High surge current capability.
- Glass passivated chip junction.
- Lead-free part meets RoHS requirements.

Mechanical data

- Epoxy: UL94-V0 rated flame retardant.
- Case: Molded plastic, SOD-123H/MINI SMA
- Terminals: Solderable per MIL-STD-750, Method 2026.
- Polarity: Indicated by cathode band.
- Mounting Position: any
- Weight: 0.011 grams approx.

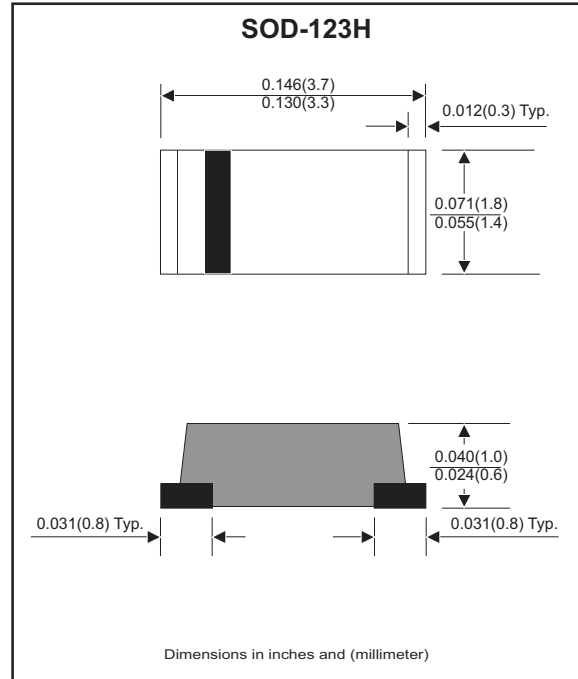

Maximum Ratings (at TA=25°C unless otherwise noted)

Parameter	Symbol	CURMT 101-HF	CURMT 102-HF	CURMT 103-HF	CURMT 104-HF	CURMT 105-HF	CURMT 106-F	CURMT 107-HF	Unit
Max. Repetitive peak reverse voltage	V_{RRM}	50	100	200	400	600	800	1000	V
Max. Continuous reverse voltage	V_R	50	100	200	400	600	800	1000	V
Max. RMS voltage	V_{RMS}	35	70	140	280	420	560	700	V
Max. Forward rectified current Ambient temperature=50°C	I_o	1.0							A
Max. Forward voltage @ $I_F=1.0A$	V_F	1.00		1.30		1.70			V
Max. Reverse recovery time (note 1)	T_{RR}	50				75			ns
Max. Forward surge current 8.3ms single half sine-wave superimposed on rated load (JEDEC method)	I_{FSM}	25							A
Max. Reverse current	$V_R=V_{RRM}$ $T_J=25^\circ C$	5.0							μA
	$V_R=V_{RRM}$ $T_J=100^\circ C$	150							
Typ. Thermal resistance Junction to ambient air	$R_{\theta JA}$	42							°C/W
Typ. Diode Junction capacitance $f=1MHz$ and applied 4V DC reverse voltage	C_J	70							pF
Operating junction temperature	T_J	-55 to +150							°C
Storage temperature range	T_{STG}	-65 to +175							°C

Note 1. Reverse recovery time test condition, $I_F=0.5A, I_R=1.0A, I_{RR}=0.25A$

Rating and Characteristic Curves (CURMT101-HF Thru. CURMT107-HF)

Fig.1- Typical Forward Current Derating Curve

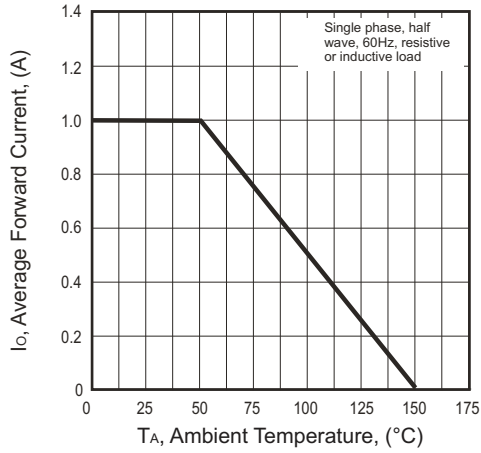

Fig.2- Typical Forward Characteristics

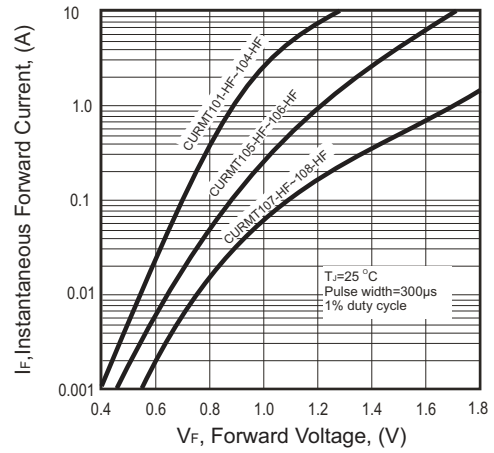
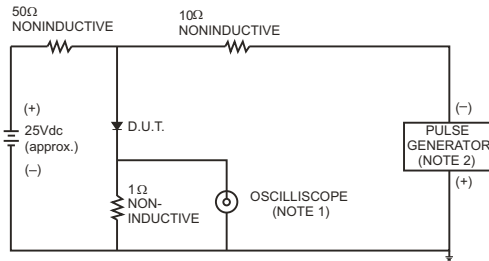

Fig.3- Test Circuit Diagram and Reverse Recovery Time Characteristics



NOTES: 1. Rise Time = 7ns max., Input Impedance = 1 megohm. 22pF.
2. Rise Time = 10ns max., Source Impedance = 50 ohms.

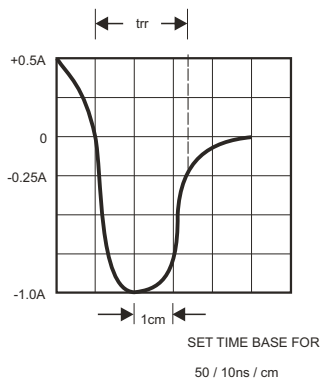

Fig.4- Maximum Non-repetitive Forward Surge Current

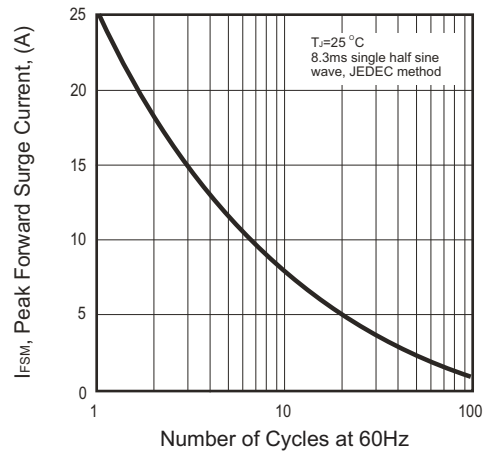
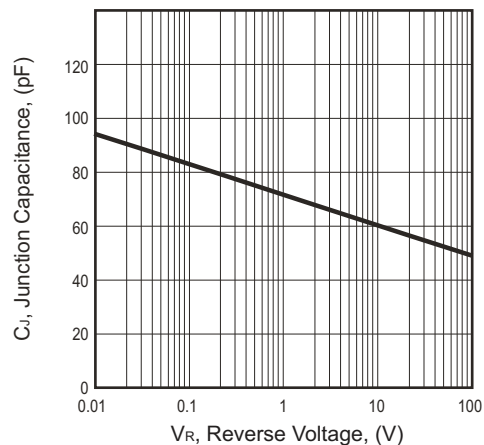
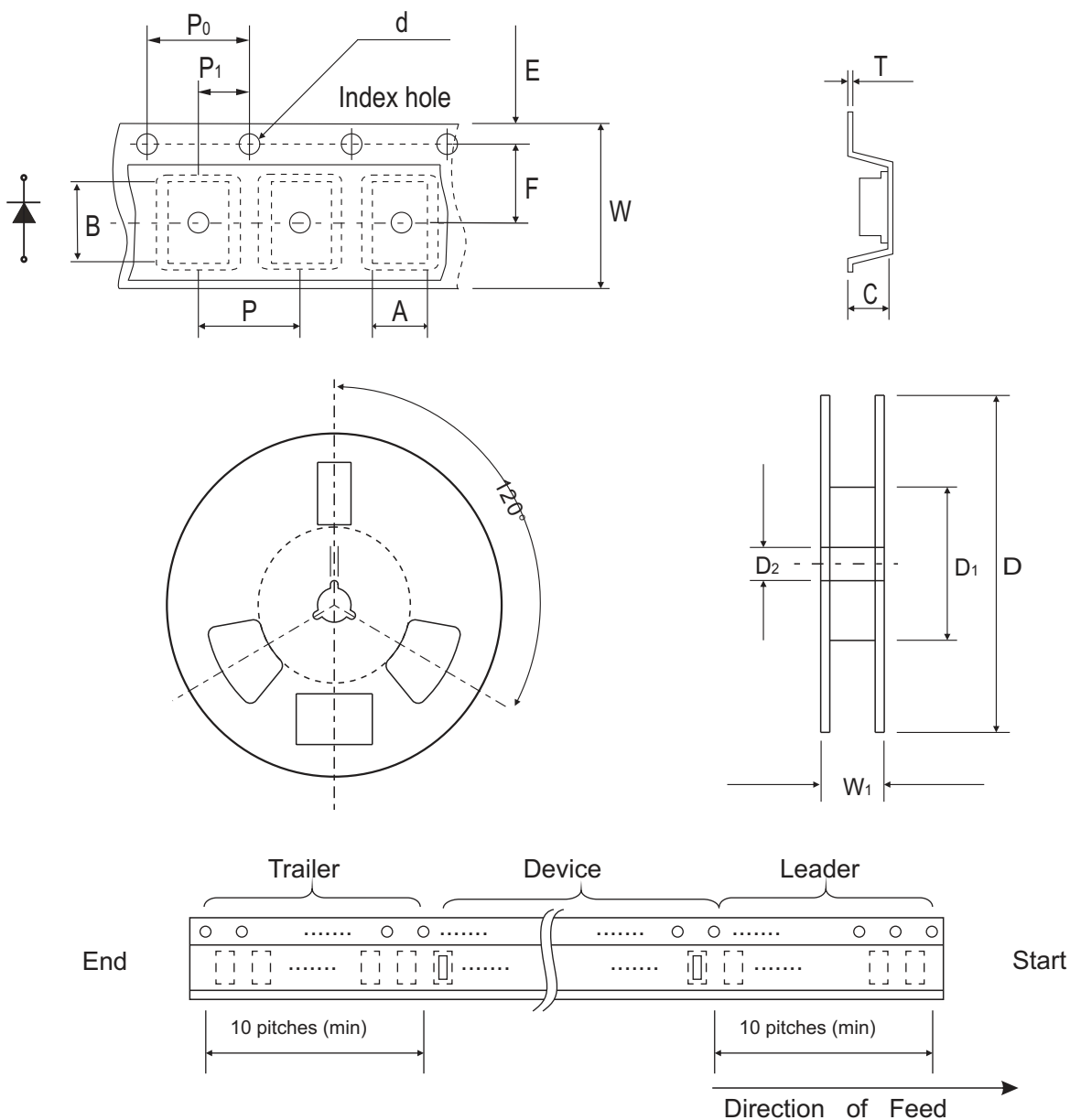

Fig.5- Typical Junction Capacitance



Reel Taping Specification



SOD-123H	SYMBOL	A	B	C	d	D	D1	D2
	(mm)	2.00 ± 0.10	3.85 ± 0.10	1.10 ± 0.10	1.50 ± 0.10	178 ± 2.00	62.0 MIN.	13.0 ± 0.50
	(inch)	0.079 ± 0.004	0.152 ± 0.004	0.043 ± 0.004	0.059 ± 0.004	7.00 ± 0.079	2.440 MIN.	0.512 ± 0.020

SOD-123H	SYMBOL	E	F	P	P0	P1	T	W	W1
	(mm)	1.75 ± 0.10	3.50 ± 0.10	4.00 ± 0.10	4.00 ± 0.10	2.00 ± 0.10	0.23 ± 0.10	8.00 ± 0.30	11.40 ± 1.0
	(inch)	0.069 ± 0.004	0.138 ± 0.004	0.157 ± 0.004	0.157 ± 0.004	0.079 ± 0.004	0.009 ± 0.004	0.315 ± 0.012	0.449 ± 0.039

Pinning information

Pin	Simplified outline	Symbol
PIN 1 Cathode PIN 2 Anode		

Marking Code

Part Number	Marking Code
CURMT101-HF	H1
CURMT102-HF	H2
CURMT103-HF	H3
CURMT104-HF	H4
CURMT105-HF	H5
CURMT106-HF	H6
CURMT107-HF	H7



xx = Product type marking code

Suggested PAD Layout

SIZE	SOD-123H	
	(mm)	(inch)
A	3.00	0.118
B	1.30	0.051
C	1.80	0.071
D	4.30	0.169
E	1.70	0.067

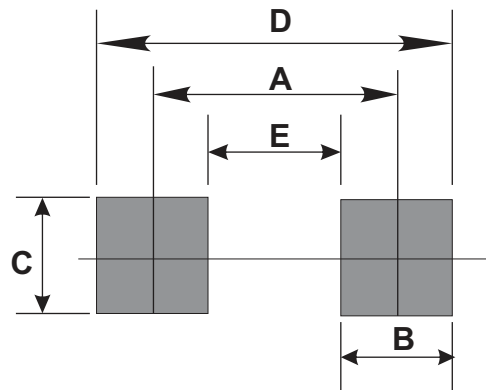

Standard Packaging

Case Type	REEL PACK	
	REEL (pcs)	Reel Size (inch)
SOD-123H	3,000	7