

THIS DRAWING IS UNPUBLISHED
 RELEASED FOR PUBLICATION 2015
 © COPYRIGHT 2015 BY TE CONNECTIVITY ALL RIGHTS RESERVED.

LOC	DIST	REVISIONS			
P	LTR	DESCRIPTION	DATE	DWN	APVD
	1	NEW DEVELOPMENTAL RELEASE	12JAN2015	JA	DM
	2	REVISED PER ECO-15-004372	19MAR2015	JA	DM
	A	PRODUCTION RELEASE PER ECO-15-014220	01OCT2015	JA	DM
	A1	REVISED PER PCN :E-18-011823	23JUL2018	DD	DM

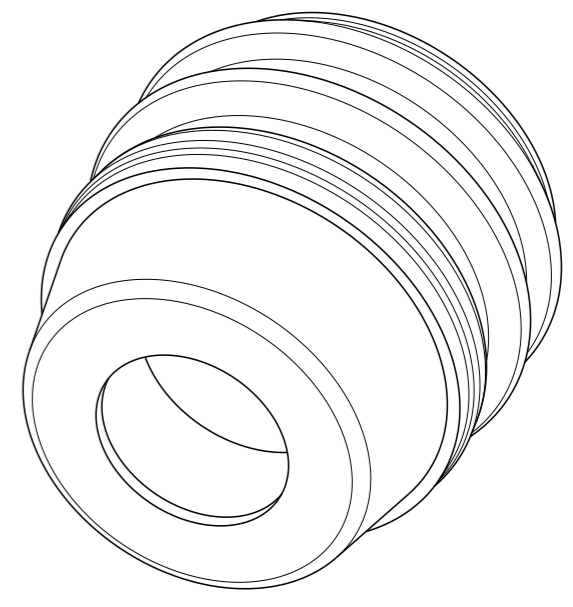
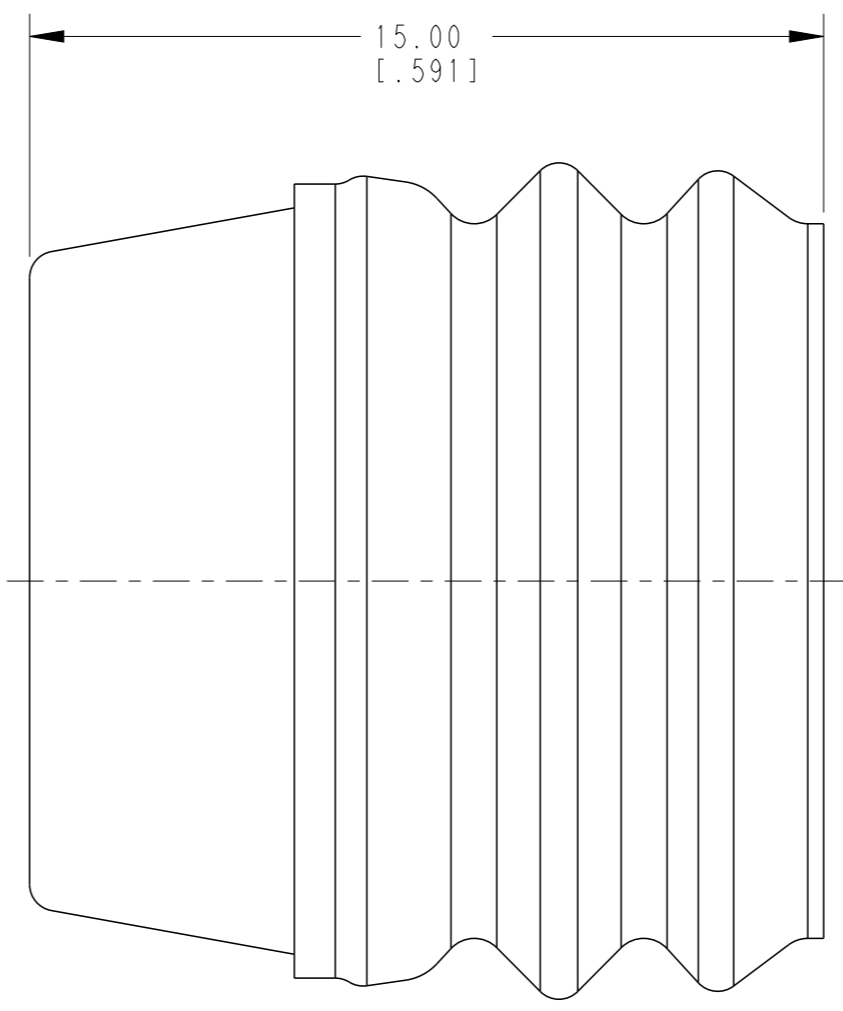
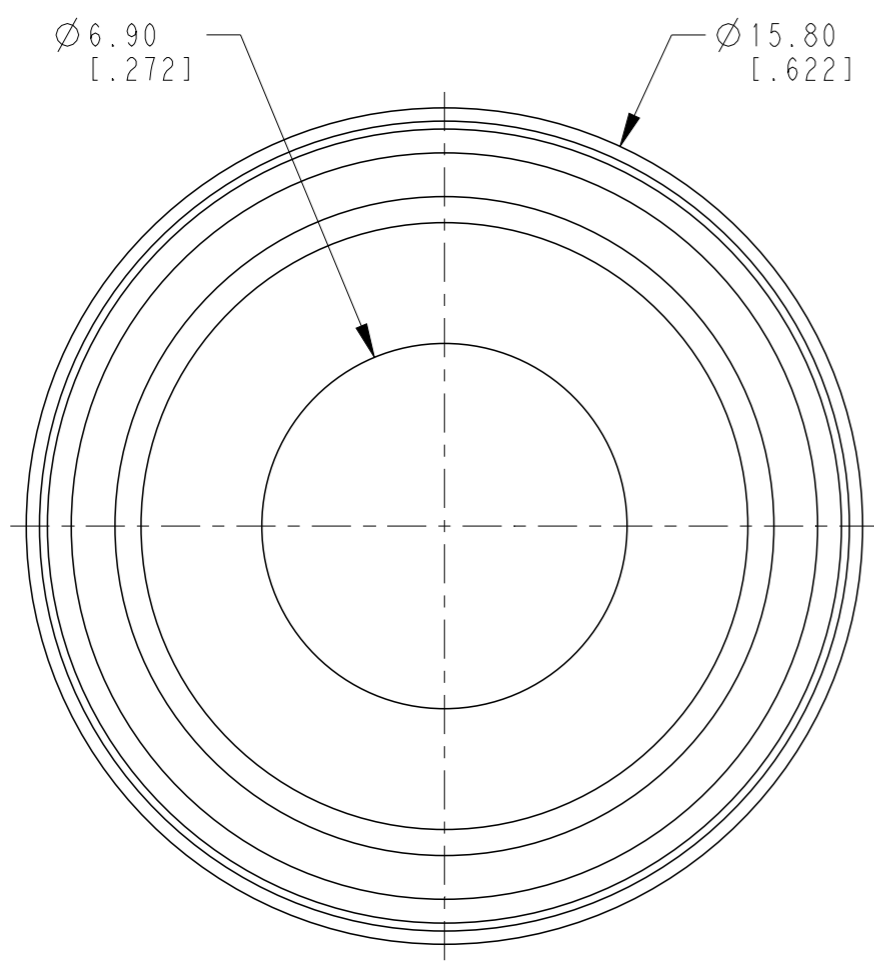

SCALE 4:1

TE INTERNAL PN	DEUTSCH PN	WIRE SEALING RANGE
2289241-1	WS-25-001	8.17-9.66 [.322-.380]

2 MATERIAL: SILICONE (VMQ), COLOR: BLUE.
 1. PART IS USED ON RECEPTACLE DTSK04-1-08PX AND PLUG DTSK06-1-08SX. (X = A,B,C KEYS)

NOTES: UNLESS OTHERWISE SPECIFIED

THIS DRAWING IS A CONTROLLED DOCUMENT.		DWN 12JAN2015 JAIME C. APOSTOL	STE TE Connectivity	
DIMENSIONS: mm [INCHES]		CHK 12JAN2015 DENNIS WHITACRE		
TOLERANCES UNLESS OTHERWISE SPECIFIED:		APVD 12JAN2015 DAVID MEYER	NAME WIRE SEAL, 25mm ² SEAL RANGE - 8.17mm-9.66mm Ø8mm CONTACT	
0 PLC ± 1 PLC ± 2 PLC ±0.64 [.025] 3 PLC ± 4 PLC ±		PRODUCT SPEC 108-151027	SIZE CAGE CODE DRAWING NO RESTRICTED TO	
MATERIAL 2		FINISH ±	114-151028	
		ANGLES ±0°30'0"	WEIGHT 1.88g	
			A3 4AFU8 C=WS-25-001	
			CUSTOMER DRAWING SCALE 7:1 SHEET 1 OF 1 REV A1	