

# 3110PS (80<sup>□</sup> x 25<sup>L</sup>)

# NMB

EMINEBEA.COM

## General Specifications

### Allowable Ambient Temperature Range:

- 10°C ~ +70°C (Operating)
- 40°C ~ +70°C (Storage)
- (non-condensing environment)

### Motor Structure: Shaded Pole Induction Motor

### Motor Protection: Impedance Protection

## Outline

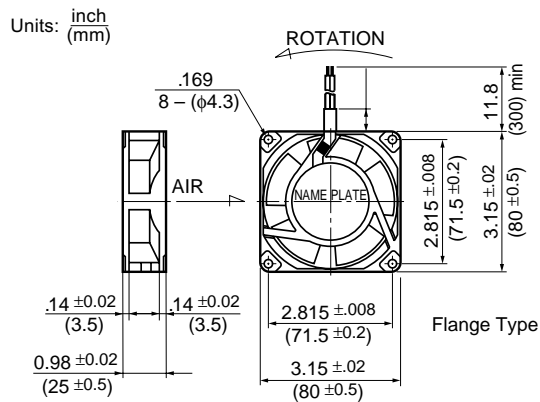

## Characteristic Curves

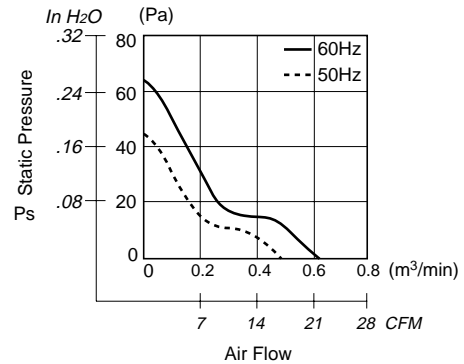

## Panel Cut-outs

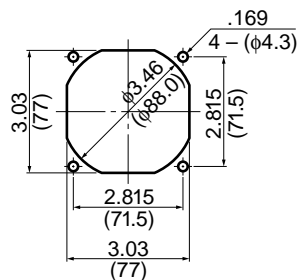

## Material

- Casing : Aluminum
- Impeller : Polycarbonate (Glass Fiber-Containing)
- Bearing : Ball Bearings
- Lead Wire : UL3266, CSA CL1252, AWG22

## Specifications

MODEL	Rated Voltage	Frequency	Starting Voltage	Current	Input Power	Speed	Max. Air Flow		Max. Static Pressure		Noise	Mass
	(V)	(Hz)	(V)	(A) <sup>*1</sup>	(W) <sup>+10% -20%</sup>	(min <sup>-1</sup> ) <sup>*2</sup>	CFM <sup>*2</sup>	(m <sup>3</sup> /min) <sup>*2</sup>	in H <sub>2</sub> O	(Pa) <sup>*2</sup>	(dB) <sup>*2</sup>	(g)
3110PS-10W-B30-B00	100	50	65	0.090	6.0	2600	16.2	0.46	15	39.2	28	220
	100	60	65	0.080	5.0	3100	19.7	0.56	21	53.9	33	220
3110PS-12W-B30-A00	115	50	65	0.085	6.0	2600	16.2	0.46	15	39.2	28	220
	115	60	65	0.075	5.0	3100	19.7	0.56	21	53.9	33	220

Rotation: Counterclockwise

Airflow Outlet: Air Out Over Struts

\*1: Maximum Values in Free Air

\*2: Average Values in Free Air