

Single-Stage Power Factor Correction Dimmable LED Driver with 3.3V Voltage Regulator Output

DESCRIPTION

The TS19820 is a single-stage active power factor correction (PFC) switch-mode power supply IC supporting high PF over a wide AC input voltage range. Output current modulation dimming is controlled from a dedicated pin capable of either PWM or linear analog signal input. The TS19820 achieves high accuracy line- and load-regulation in discontinuous conduction mode (DCM) architecture. Output switching regulation is controlled with pulse frequency modulation (PFM) which is particularly suited for high conversion efficiency and high PF even at low output power levels. The TS19820 also features a 3.3V LDO output for MCU applications. Integrated protection features such as an external switching MOSFET gate drive voltage clamp, V_{CC} over-voltage protection, and system output open/short circuit protection increase system reliability.

FEATURES

- Supports PWM & Linear dimming
- Embedded 3.3V LDO output for MCU
- Low cost BOM
- High Power Factor >0.9
- Pulse Frequency Modulation (PFM) Control
- Discontinuous Conduction Mode Control
- No Opto-Coupler Required
- Gate output voltage clamp
- LED open and short protection
- Over Current Protection (OCP)
- Internal Over Temperature Protection (OTP)
- Low start-Up current
- Compliant to RoHS Directive 2011/65/EU and in accordance to WEEE 2002/96/EC.
- Halogen-Free according to IEC 61249-2-21

APPLICATION

- Smart LED lighting
- Infrared remote control light
- Motion sensing LED light



Pin Definition:

- | | |
|--------|-------------|
| 1. CS | 8. V_{CC} |
| 2. DIM | 7. OUT |
| 3. COM | 6. GND |
| 4. LDO | 5. ZCDX |

Notes: MSL 3 (Moisture Sensitivity Level) per J-STD-020

TYPICAL APPLICATION CIRCUIT

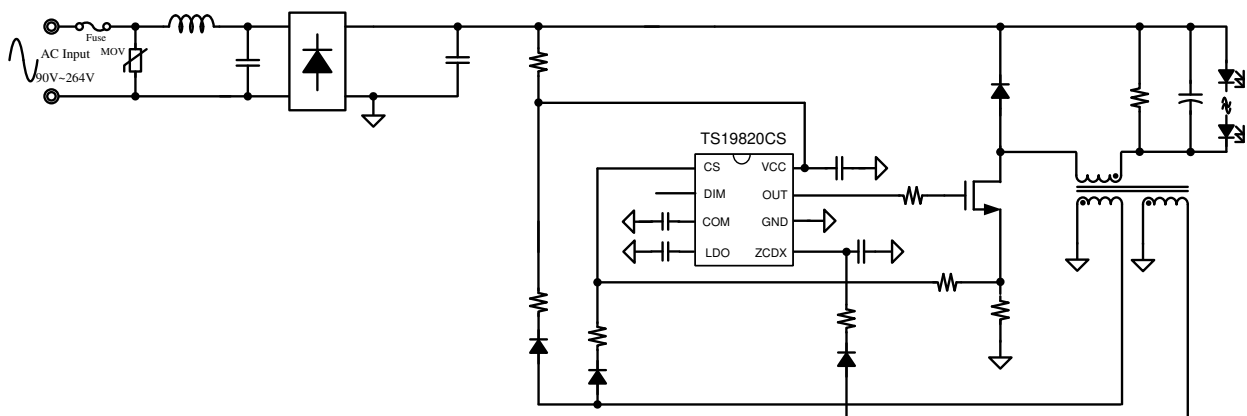

ABSOLUTE MAXIMUM RATINGS ($T_A = 25^\circ\text{C}$ unless otherwise specified) ^(Note 1)			
PARAMETER	SYMBOL	LIMIT	UNIT
Power Supply Pin	V_{CC}	40	V
DIM Voltage to GND	V_{RT}	-0.3 to 5.5	V
OUT Voltage to GND	V_{OUT}	-0.3 to 40	V
CS Voltage to GND	V_{CS}	-0.3 to 5.5	V
ZCDX Voltage to GND	V_{ZCDX}	-0.3 to 40	V
LDO Voltage to GND	V_{LDO}	-0.3 to 5.5	V
COM Voltage to GND	V_{COM}	-0.3 to 5.5	V
Operating Temperature Range	T_{OPR}	-40 to 105	$^\circ\text{C}$
Junction Temperature Range	T_J	-40 to +150	$^\circ\text{C}$
Storage Temperature Range	T_{STG}	-65 to +150	$^\circ\text{C}$
Lead Temperature (Soldering 10 sec)	T_{LEAD}	260	$^\circ\text{C}$
Power Dissipation @ $T_A=25^\circ\text{C}$	P_D	0.6	W
ESD Rating (Human Body Mode) ^(Note 2)	HBM	2	kV
ESD Rating (Machine Mode)	MM	200	V

THERMAL PERFORMANCE			
PARAMETER	SYMBOL	LIMIT	UNIT
Thermal Resistance - Junction to Case	$R_{\theta JC}$	50	$^\circ\text{C/W}$
Thermal Resistance - Junction to Ambient	$R_{\theta JA}$	208	$^\circ\text{C/W}$

RECOMMENDED OPERATING CONDITIONS ^(Note 3)			
PARAMETER	SYMBOL	LIMIT	UNIT
Power Supply Pin	V_{CC}	20	V
DIM Voltage to GND	V_{OTP}	-0.3 to 5	V
OUT Voltage to GND	V_{OUT}	-0.3 to 19	V
CS Voltage to GND	V_{CS}	-0.3 to 5	V
COM Voltage to GND	V_{COM}	-0.3 to 5	V
ZCDX Voltage to GND ^(Note 3)	V_{ZCDX}	3.5 to 20	V
Operating Junction Temperature Range	T_J	-40 to +125	$^\circ\text{C}$
Operating Ambient Temperature Range	T_{OPA}	-40 to +85	$^\circ\text{C}$

ELECTRICAL SPECIFICATIONS ($V_{CC} = 18V$, $T_A = 25^{\circ}C$ unless otherwise noted)						
PARAMETER	CONDITIONS	SYMBOL	MIN	TYP	MAX	UNIT
Supply Voltage						
Start-up Current	$V_{CC} = V_{UVLO(ON)} - 1V$	$V_{CC(ST)}$	--	57	--	μA
Operating Current	With 1nF load on out pin	I_{OPA}	--	2	2.6	mA
Under Voltage Lock Out (off)		$V_{UVLO(off)}$	6.5	8	9.5	V
Under Voltage Lock Out (on)		$V_{UVLO(ON)}$	16	17.5	19	V
OVP Level on V_{CC} Pin		V_{OVP}	30.5	32	33.5	V
Voltage Feedback						
Feedback Reference Voltage		V_{FB}	0.19	0.2	0.21	V
Current Sensing						
CS Limit Voltage		V_{OCP}	--	1.0	--	V
Leading-Edge Blanking Time		LEB_t	--	280	--	Ns
Switching Frequency						
Start Frequency		f_{STR}	3	4.5	6	kHz
Low Drop Out regulator						
Reference Voltage	$V_{ZCDX} = 10V$, $I_o = 30mA$	V_{LDO}	3.1	3.3	3.5	V
Load Regulation	$V_{ZCD} = V_o + 6.7V$ $I_o = 10mA \sim 30mA$	REG_{LOAD}	--	0.6	--	%
Line Regulation	$V_o + 2.7V < V_{ZCDX} < 40V$ $I_o = 10mA$	REG_{LINE}	--	0.3	--	%
Gate Driver Output						
Rising Time	Load Capacitance = 1nF	t_{RISE}	--	240	--	ns
Falling Time	Load Capacitance = 1nF	t_{FALL}	--	120	--	ns
VGATE-Clamp		V_{GATE}	--	12.5	--	V
DIM Function (PWM-D/Linear-D)						
PWM Dimming Input High Voltage Threshold		V_{OH}	2.5	--	--	V
Linear Dimming Threshold for 100% Current Regulation		V_{MAX}	--	--	1.6	V
Thermal Section						
Thermal Shutdown ^(Note 4)			--	165	--	$^{\circ}C$
Thermal Shutdown Release ^(Note 5)			--	120	--	$^{\circ}C$

Note:

- Stresses listed as the above "Absolute Maximum Ratings" may cause permanent damage to the device. These are for stress ratings. Functional operation of the device at these or any other conditions beyond those indicated in the operational sections of the specifications is not implied. Exposure to absolute maximum rating conditions for extended periods may remain possibility to affect device reliability.
- Devices are ESD sensitive. Handling precaution recommended.
- The product dropout voltage and output current should not exceed the maximum power dissipation
- The device is not guaranteed to function outside its operating conditions.
- Guaranteed by design.
- Auto Recovery Type.

ORDERING INFORMATION

ORDERING CODE	PACKAGE	PACKING
TS19820CS RLG	SOP-8	2,500pcs / 13" Reel

FUNCTION BLOCK

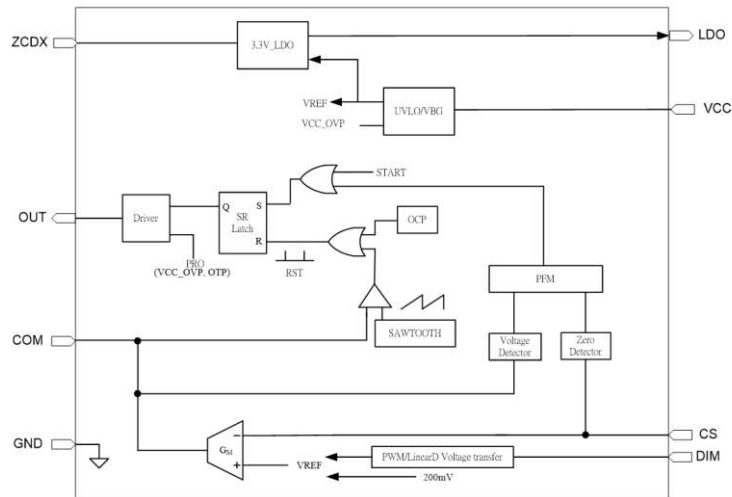

PIN DESCRIPTION

PIN NO.	NAME	FUNCTION
1	CS	Input current sense pin
2	DIM	PWM/Linear DIMMING voltage input
3	COM	Output pin of error amplifier
4	LDO	3.3V LDO output
5	ZCDX	Auxiliary Winding input for LDO power supply
6	GND	Ground return for all internal circuitry
7	OUT	Gate driver output
8	V _{CC}	Power supply pin for all internal circuitry

PIN FUNCTION DESCRIPTION

CS pin:

CS pin provides the LED current feedback function, I_{OUT} and R_S formula as below

$$R_S = \frac{0.2V/2}{I_{OUT}}$$

Where :

- R_S is the resistance
- 0.2 is a V reference for electric potential
- I_{OUT} is the current output

Also, CS pin provides over-current protection (OCP), over-current I_{CS} (Limit) and R_S formula as below:

$$I_{CS(Limit)} = \frac{1}{R_S}$$

Where :

- $I_{CS(Limit)}$ is a current sense
- 1 is a voltage value for OCP
- R_S is the resistance

DIM pin:

Output current modulation dimming can be controlled from either PWM or linear analog signal input on a dedicated pin. The linear dimming range is an analog voltage from 0V to 1.6V. The PWM dimming range is larger than 2.5V . PWM dimming control is a function of the duty cycle of external PWM signal.

COM pin:

The most important design is compensation circuit for PFC control loop. It achieves high PFC and low total harmonic distortion (THD) function. In order to remain V_{COM} is a constant value in every cycle we usually set the bandwidth under 10Hz. We recommend using 1 μ F capacitor in typ. design. If the system specification comes with higher output voltage or large output capacitor, ensure the V_{CC} voltage above $UVL_{(off)}$. If not the system will fail to start or blinking or flickering. V_{COM} level determine Switch-on time (t_{ON}). In order to avoid malfunction that recommend operating range between 1 μ s ~ 14 μ s.

LDO pin:

Provide 3.3V to MCU power supply.

ZCDX pin:

Auxiliary Winding input for LDO power supply.

GND pin:

GND is the reference node of internal circuit.

OUTPUT pin:

OUT pin has internal built-in a voltage clamp circuit. 12.5V is the maximum clamping voltage, when V_{CC} is over 12.5V which OUT pin will be clamped under 12.5V. This function is avoided the output voltage too high and damaged the MOSFET gate

V_{CC} pin:

V_{CC} pin has built-in three levels. Such as :

Start voltage level (V_{CC_ON}), Cutoff voltage level (V_{CC_OFF}), Over-voltage protection level (V_{OVP}).

When V_{CC} voltage over V_{CC_ON} level, IC will work in the system. When V_{CC} voltage over OVP level (31.5V Typ.), IC will shut down and goes into "Hiccup" mode. The IC operating between $UVLO_{(ON)}$ and $UVLO_{(OFF)}$, 8 times per cycle until the OVP condition is removed.

APPLICATION INFORMATION

Functional Description

The TS19820 is a single stage Buck PFC controller. It adopts the proprietary control architecture to achieve an accurate regulation of LED current, unity power factor, and quasi-resonant valley plus time delay adjust turn-on operation. High power factor is achieved by constant on-time operation mode, which the control scheme and the circuit structure are both simple.

According to the following formula, assume Switch-on time (t_{ON}) is a constant, inductor peak current ($I_{L_{pk}}$) and the AC input voltage will become a linear relationship in half sine wave shape. Thus we can estimate " $I_{IN_{pk}}$ " will also be a sine wave shape to achieve high power factor and reduce inductance in DCM mode.

$$V = L \frac{di}{dt} \Rightarrow \frac{V}{L} = \frac{I_{L_{pk}}}{t_{on}} \Rightarrow I_{L_{pk}} = \frac{V}{L} t_{on}$$

Where :

- V : Voltage
- L : Inductor
- di : Differential to current
- dt : Differential to time
- $I_{L_{pk}}$: Peak of current and inductance
- t_{ON} : Constant On-time

TS19820 operates in discontinues conduction mode (DCM) as shown in Figure 1. Switching point is controlled by CS voltage, and the frequency is changing with the input instantaneous line voltage. General suggestion is used 40kHz ~150kHz by switching frequency in system that obtain better performances. The max on time is 13 μ s ~ 14 μ s .CS pin detect MOSFET current from CS resister. TS19820 can control the output average current accurately regardless of any changes about AC input voltage and output voltage (LED V_F).

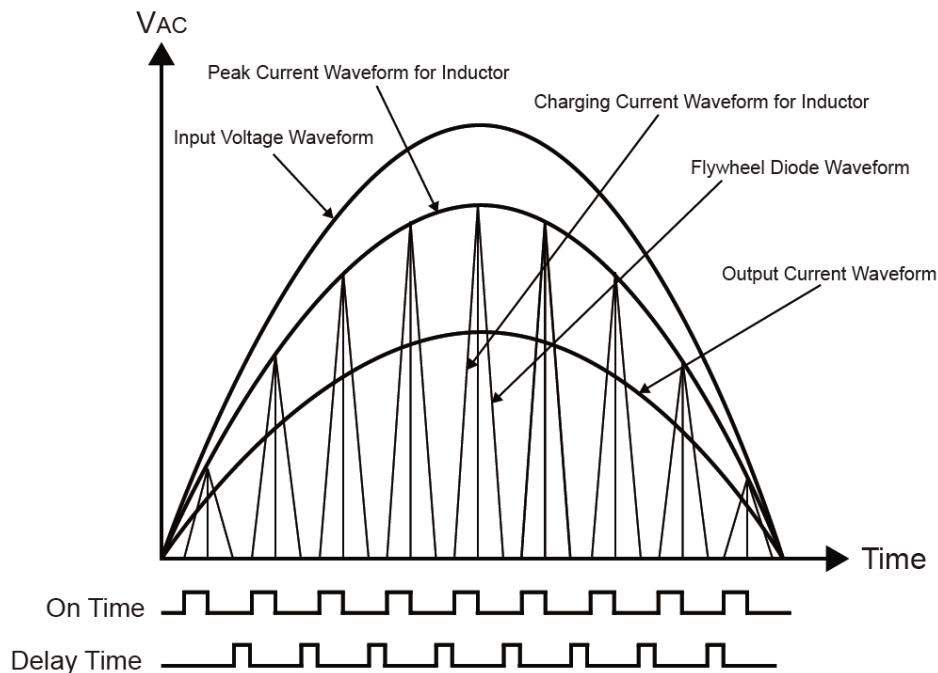
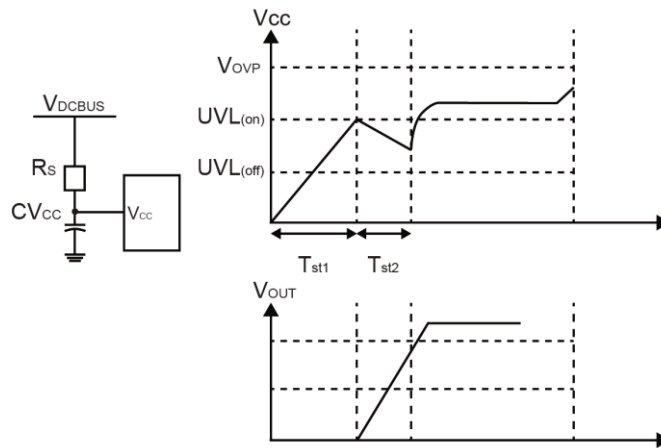

Figure 1: Constant on-time diagram

APPLICATION INFORMATION (CONTINUE)

Start-up

After AC supply or DC BUS is powered on, the capacitor CV_{CC} across V_{CC} and GND pin is charged up by DC BUS voltage through a start-up resistor R_S . Once V_{CC} rises up to $UVLO_{(ON)}$, the internal blocks start to work. The whole start up procedure is divided into two sections shown in Fig.2. T_{st1} is the CV_{CC} charged up section, and T_{st2} is the output voltage built-up section. The start-up time T_{st} composes of T_{st1} and T_{st2} , and usually T_{ST1} is much larger than T_{st2} .



The start-up resistor R_S and CV_{CC} are designed by rules below:

- (a) Preset start-up resistor R_S , make sure that the current through R_S is larger than I_{ST}
Where I_{ST} is the Start-up Current.

$$\frac{V_{DCBUS}}{I_{vcc_ovp}} < R_S < \frac{V_{DCBUS}}{I_{st}}$$

- (b) Select CV_{CC} to obtain an ideal start up time T_{st} , and ensure the output voltage is built up.

$$UVLO_{(ON)} = V_{DCBUS} * (1 - e^{-T_{st1} / (R_S * CV_{CC})})$$

- (c) If the CV_{CC} is not big enough to build up the output Increase CV_{CC} and decrease R_S , go back to step (a) and redo such design flow until the ideal start up procedure is obtained.

Constant current control

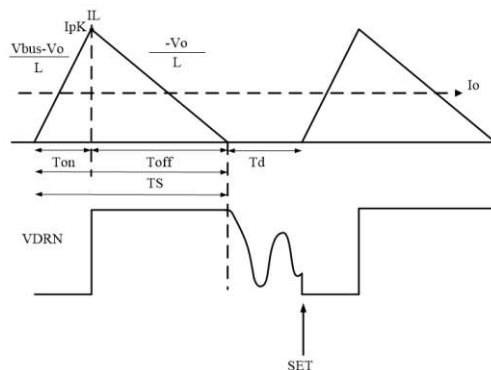

Figure 2

The switching waveforms are shown in Fig.2. The output current I_{OUT} can be represented by:

$$\frac{1}{2} * I_{pk} * (T_{on} + T_{off}) = I_{out} \quad (1)$$

APPLICATION INFORMATION (CONTINUE)

Where I_{PK} is the peak current of the inductor; T_s is the effective time of inductor current rising and falling; T_s+T_d is the switching period.

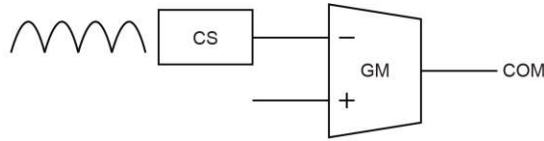

Figure 3

In static state, the positive and negative inputs are equal.

$$\frac{1}{2} * \frac{1}{2} * I_{pk} * (T_{on} + T_{off}) * R_{cs} = V_{ref}$$

According to (1)

Where V_{REF} is the internal reference voltage, R_{CS} is the current sense resistor; I_{OUT} can be programmed by R_{CS} .

Over Voltage Protection (OVP) on V_{CC}

When the V_{CC} voltage higher than OVP voltage (31.5V Typ.), the output gate driver circuit will shut down immediately. Then switching is shut down and V_{CC} goes into “Hiccup” mode, V_{CC} voltage will gradually be released to V_{CC_OFF} (8V Typ.). In this condition the IC operating between $UVLO_{(ON)}$ and $UVLO_{(OFF)}$ with eight times per cycle until the OVP condition is removed. The TS19820 is working in an auto-recovery mode as shown in Fig.4

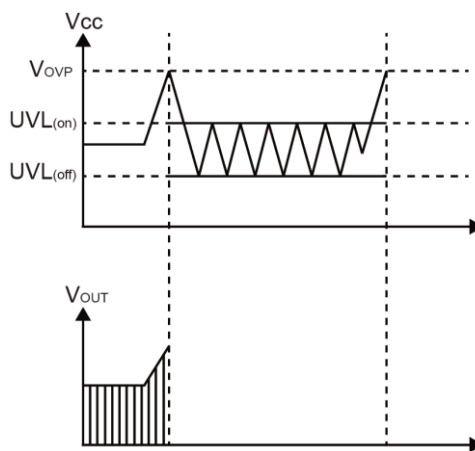

Figure 4

Over Current Protection (OCP)

TS19820 detects the MOSFET current from CS pin, which is for the cycle-by-cycle current limit and output feedback. The current limit threshold of CS pin is set at 1.0V (Typ.).

Over Temperature Protection (OTP)

When the IC internal temperature is over 150°C (Thermal Shutdown Typ.), the IC will stop and shut-down output signal which means into OTP status. While the IC internal temperature drops until to 120°C (Thermal Shutdown Release Typ.), the IC will be re-set automatically.

Short Circuit Protection (SCP)

When the output is shorted, the IC will be automatically shut down. Because of the V_{CC} power is lost from power supply.

TYPICAL PERFORMANCE CURVES

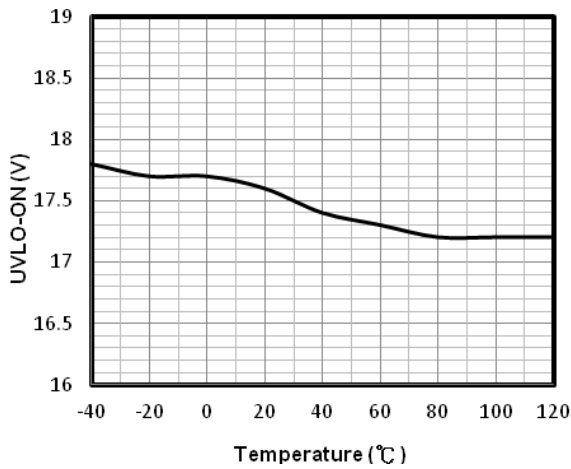

Figure 1. UVLO-ON vs. Ambient Temperature

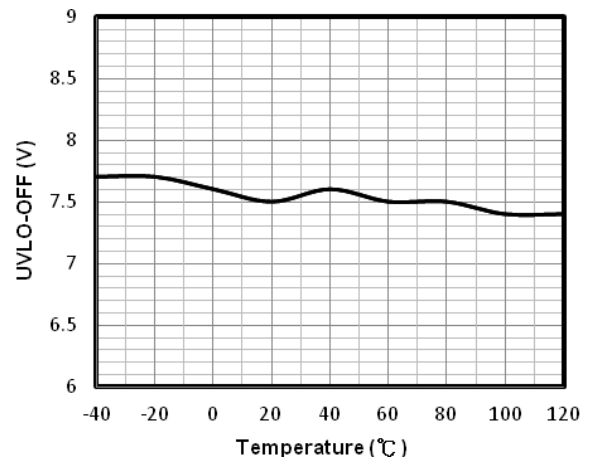

Figure 2 – UVLO-OFF vs. Ambient Temperature

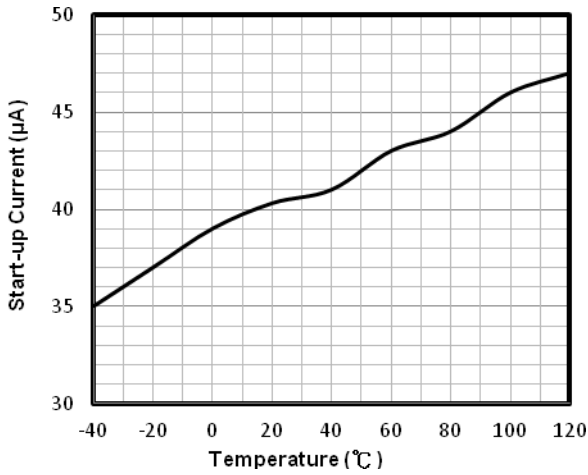

Figure 3 – Start-up Current vs. Ambient Temperature

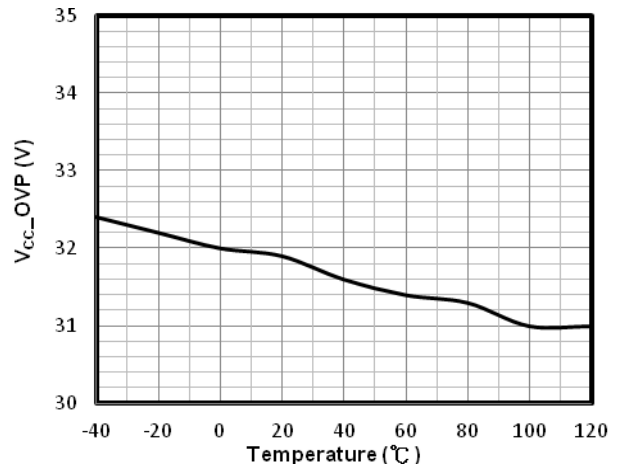

Figure 4 – OVP vs. Ambient Temperature

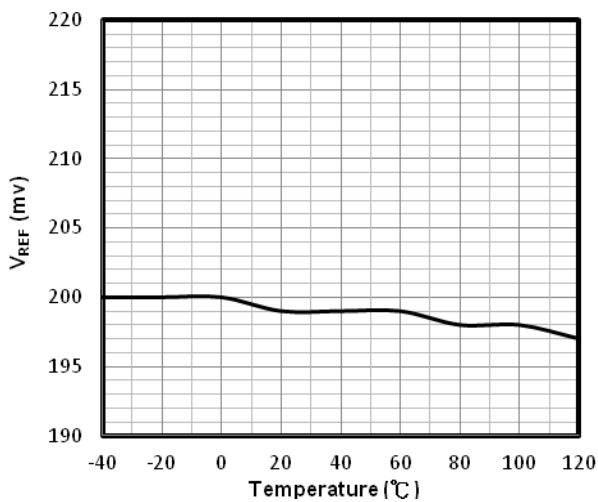

Figure 5– VREF vs. Ambient Temperature

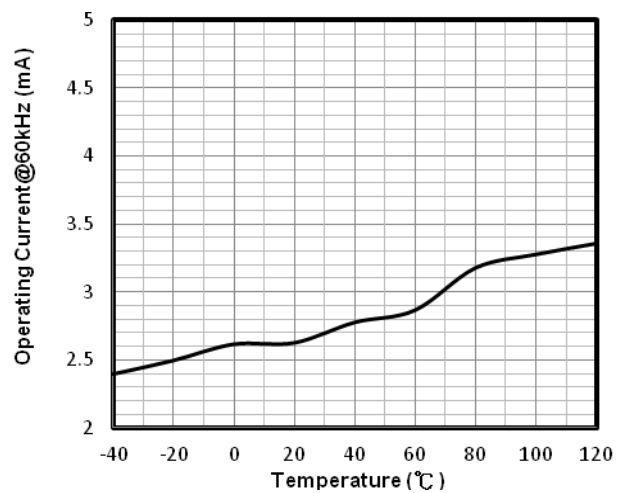

Figure 6 – Operating Current vs. Ambient Temperature

TYPICAL PERFORMANCE CURVES

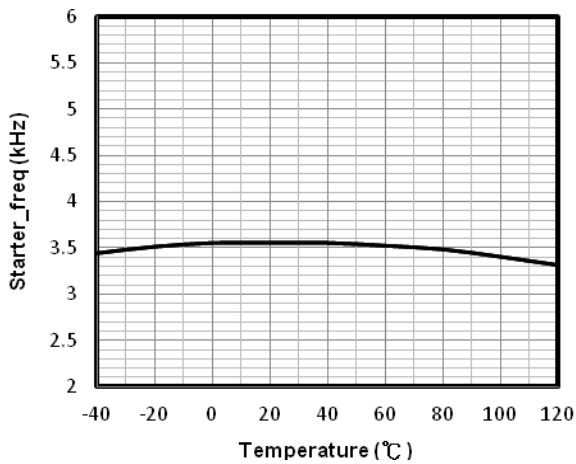

Figure 7– Starter Frequency vs. Ambient Temperature

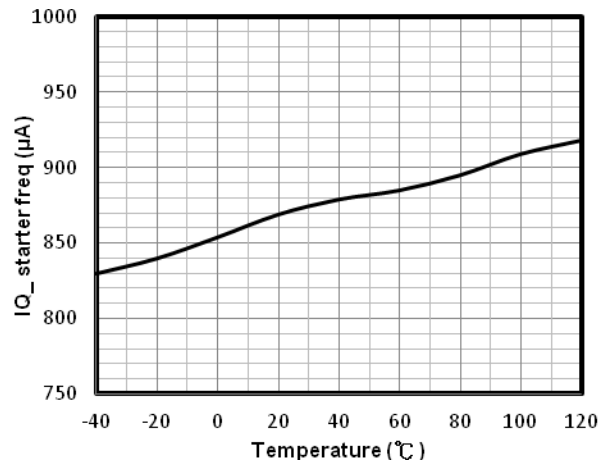

Figure 8 – Operating Current at starter vs. Ambient Temperature

POWER DEVICE DESIGN

MOSFET & Diodes

When the operation condition is with maximum input voltage and full load, the voltage stress of MOSFET and output power diode is maximized;

$$V_{MOS_dsmax} = \sqrt{2} V_{ac_max}, V_{diode_rmax} = \sqrt{2} V_{ac_max}$$

Where V_{AC_max} is maximum input AC RMS voltage.

When the operation condition is with minimum input voltage and full load, the current stress of MOSFET and power diode is maximized.

Inductor (L)

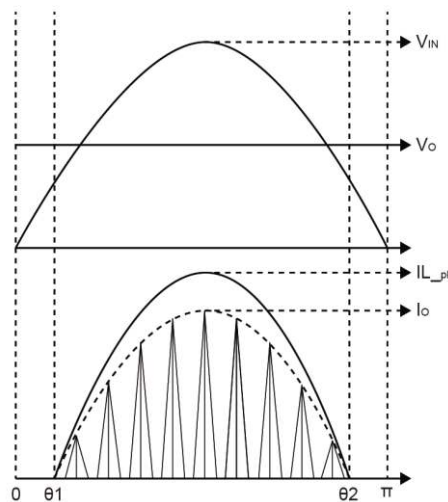

Figure.5

POWER DEVICE DESIGN (CONTINUE)

In Buck converter when the input voltage is larger than output voltage, the power is transferred from AC input to output. The input voltage and inductor current waveforms are shown in Fig. 5, where θ_1 and θ_2 are the time that input voltage is equal to output. In discontinues mode, each switching period cycle T_s consists of three parts : current rising time T_{ON} , falling time T_{OFF} and delay time T_d shown in Fig.5.

The system operates in the constant on time mode to achieve high power factor. The on time increases with the input AC rms voltage decreasing and the load increasing. When the operation condition is with minimum input AC rms voltage and full load, the on time and CS voltage are maximized. On the other hand when the input voltage is at the peak value, the off time is maximized. IC base on CS voltage adjust T_d CS voltage high T_d increase low T_d decrease Thus, the minimum switching frequency F_{S_min} happens at the peak value of input voltage once the minimum frequency F_{S_min} is set, the inductance of the transformer could be calculated. The design flow is shown as below:

- (a) Preset minimum frequency F_{S_min}
- (b) Compute relative T_c , T_{on}

$$T_c = \frac{1}{F_{S_min}}, T_{on} = \frac{V_{out} + V_d}{\sqrt{2}V_{AC_min}} * T_c, T_{off} = T_c - T_{on} - T_d$$

$$\theta_1 = \arcsin\left(\frac{V_{out}}{\sqrt{2}V_{AC_min}}\right), \theta_2 = \pi - \theta_1$$

- (c) Compute inductor maximum peak current
Where η is the efficiency;

$$I_{L_pk} = 2 * I_{LED} * \pi * \frac{\sqrt{2}V_{ac_min} - V_o}{\sqrt{2}V_{ac_min} * (2\cos\theta - \frac{V_{out} - 2V_o}{\sqrt{2}V_{ac_min}})} * \frac{1}{\eta}$$

- (d) Design inductance L

$$L = \frac{(V_{out} + V_D) * T_{off}}{I_{L_pk}}$$

- (e) Compute RMS current of the inductor

I is Inductor RMS current of whole AC period with minimum input AC RMS voltage and maximum load condition meanwhile, the maximum peak current through MOSFET and the transformer happens.

$$I_{L_RMS} = \frac{T_{on}}{\sqrt{3} * L} * \sqrt{V_{ac_min}^2 + V_{out}^2 - \frac{4\sqrt{2}V_{ac_min} * V_{out}}{\pi}}$$

- (f) compute RMS current of the MOSFET

$$I_{L_RMS} = \sqrt{\frac{T_{on}}{3T_s} * \frac{T_{on}}{L} * \sqrt{V_{ac_min}^2 + V_{out}^2 - \frac{4\sqrt{2}V_{ac_min} * V_{out}}{\pi}}}$$

Output capacitor

Preset the output current ripple ΔI_{OUT} , C_{OUT} is induced by

$$C_{OUT} = \frac{\sqrt{\left(\frac{I_{out}}{\Delta I_{out}}\right)^2 - 1}}{4\pi f_{ac} R_{LED}}$$

Where I_{OUT} is the rated output current; ΔI_{OUT} is the demanded current ripple; f_{AC} is the input AC supply frequency; R_{LED} is the equivalent series resistor of the LED load.

LAYOUT GUIDE

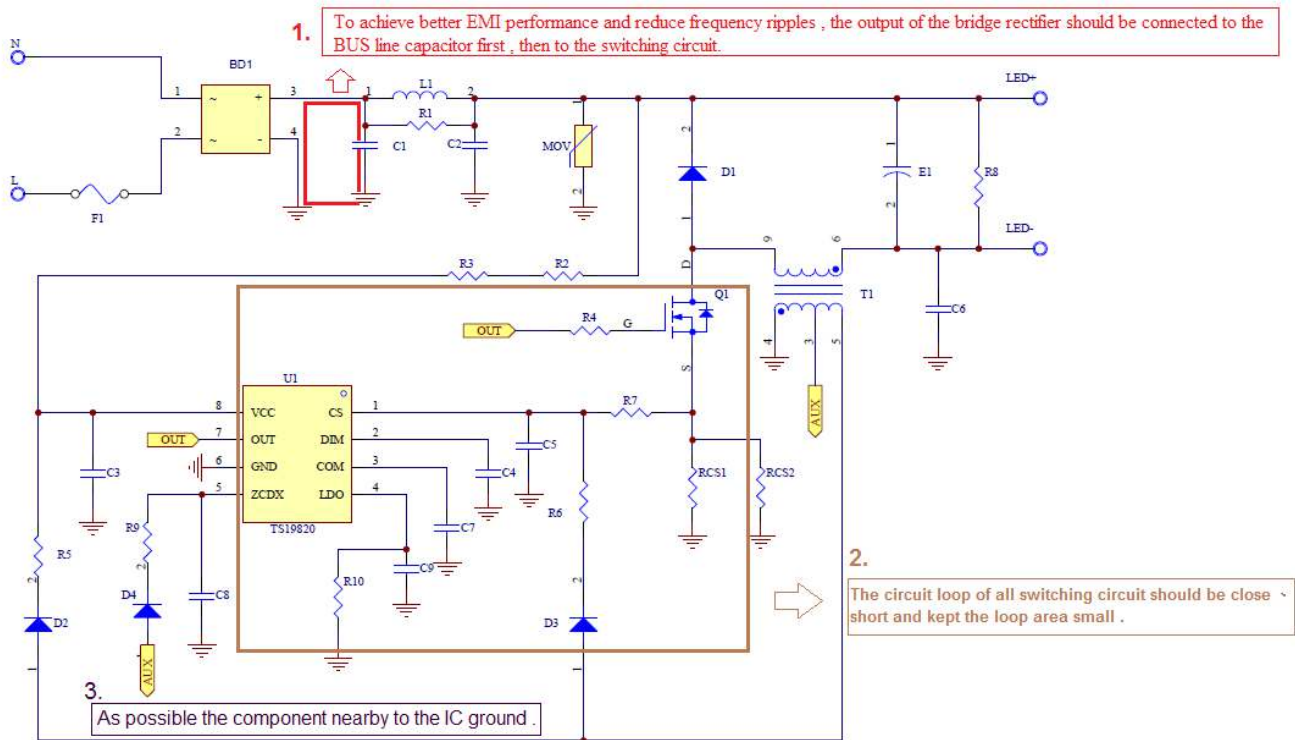

PACKAGE OUTLINE DIMENSIONS (Unit: Millimeters)

SOP-8

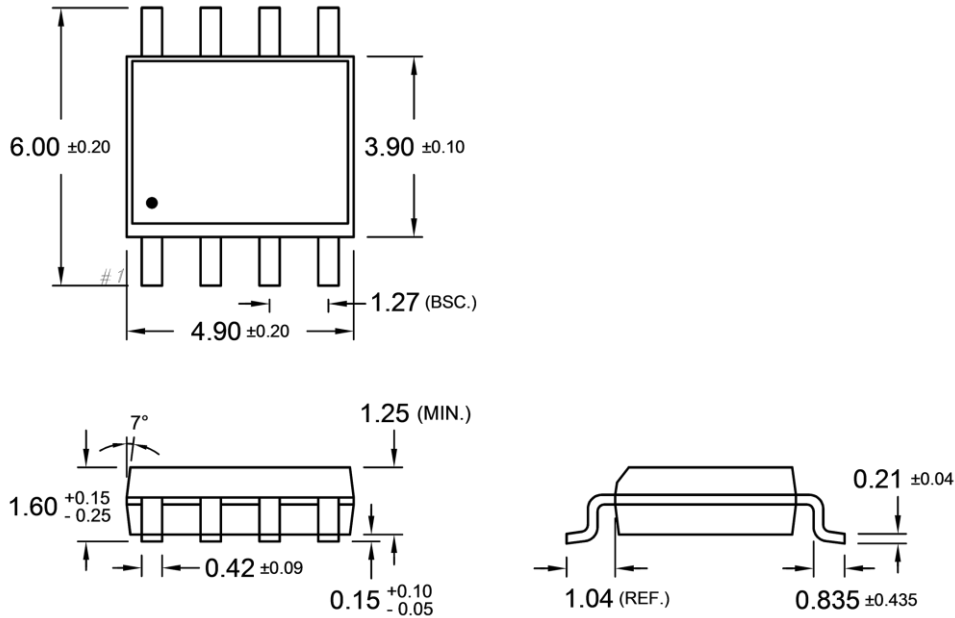

SUGGESTED PAD LAYOUT (Unit: Millimeters)

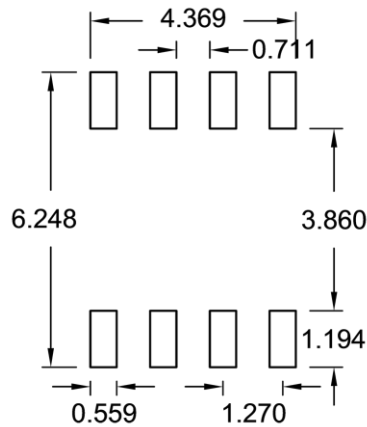

MARKING DIAGRAM

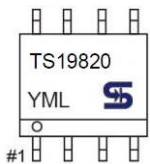

- Y** = Year Code
- M** = Month Code for Halogen Free Product
- O** =Jan **P** =Feb **Q** =Mar **R** =Apr
- S** =May **T** =Jun **U** =Jul **V** =Aug
- W** =Sep **X** =Oct **Y** =Nov **Z** =Dec
- L** = Lot Code (1~9, A~Z)

Notice

Specifications of the products displayed herein are subject to change without notice. TSC or anyone on its behalf, assumes no responsibility or liability for any errors or inaccuracies.

Information contained herein is intended to provide a product description only. No license, express or implied, to any intellectual property rights is granted by this document. Except as provided in TSC's terms and conditions of sale for such products, TSC assumes no liability whatsoever, and disclaims any express or implied warranty, relating to sale and/or use of TSC products including liability or warranties relating to fitness for a particular purpose, merchantability, or infringement of any patent, copyright, or other intellectual property right.

The products shown herein are not designed for use in medical, life-saving, or life-sustaining applications. Customers using or selling these products for use in such applications do so at their own risk and agree to fully indemnify TSC for any damages resulting from such improper use or sale.