Connector, Circular Plastic

1. SCOPE

1.1. Content

This specification covers the performance, tests and quality requirements for the AMP* circular electrical connectors (plugs and receptacles) with removable crimp contacts. These connectors are designed for use in electronic, electric power and control circuits.

1.2. Classification

Connectors shall be of the following series, classes and shell sizes specified on the applicable product drawing.

A. Series

- Standard density using size 16 (.062 inch diameter) contacts
- High density using size 20 (.040 inch diameter) contacts
- Power using Type XII contacts
- Combination using standard and power contacts

B. Class

- Pressurized receptacle
- General purpose
- Environment resisting general purpose with jacketed cable and interfacial seals

C. Shell Sizes

11, 13, 17 and 23

1.3. Qualification

When tests are performed on the subject product line, procedures specified in Figure 1 shall be used. All inspections shall be performed using the applicable inspection plan and product drawing.

1.4. Qualification Test Results

Successful qualification testing on the subject product line was completed on 20Aug99. The Qualification Test Report number for this testing is 501-483. This documentation is on file at and available from Engineering Practices and Standards (EPS).

2. APPLICABLE DOCUMENTS

The following documents form a part of this specification to the extent specified herein. In the event of conflict between the requirements of this specification and the product drawing, the product drawing shall take precedence. In the event of conflict between the requirements of this specification and the referenced documents, this specification shall take precedence.

2.1. AMP Documents

- A. 109-1: General Requirements for Test Specifications
- B. 109 Series: Test Specifications as indicated in Figure 1
- C. Corporate Bulletin 401-76: Cross-reference between AMP Test Specifications and Government or Commercial Documents
- D. 108-10037: Product Specification
- E. 108-10042: Product Specification
- F. 108-40005: Product Specification

- G. 114-10004: Application Specification
- H. 114-10005: Application Specification
- I. 114-10038: Application Specification
- J. 501-483: Qualification Test Report

2.2. Commercial Specification

IEC 144: Degree of Protection of Enclosures for Low-Voltage Switch Gear and Control Gear

2.3. Government Specification

MIL-W-16878/4: Wire, Electrical, Insulated, High Temperature

3. REQUIREMENTS

3.1. Design and Construction

Product shall be of the design, construction and physical dimensions specified on the applicable product drawing.

3.2. Materials

Materials used in the construction of this product shall be as specified on the applicable product drawing.

3.3. Ratings

A. Voltage:

- 1. 250 volts AC/DC
- 2. 600 volts AC/DC, Series I, VDE tested and select loaded only

B. Temperature: -55 to 105°C

C. VDE 0627: XA/630/4KV/2 - Series I, VDE tested only

3.4. Performance and Test Description

Product is designed to meet the electrical, mechanical and environmental performance requirements specified in Figure 1. Unless otherwise specified, all tests shall be performed at ambient environmental conditions per AMP Specification 109-1.

3.5. Test Requirements and Procedures Summary

Test Description	Requirement	Procedure
Examination of product.	Meets requirements of product drawing and AMP Spec 114-10038.	Visual and functional per applicable quality inspection plan.
ELECTRICAL		
Insulation resistance.	1,000 megohms minimum initial. 500 megohms minimum final.	AMP Spec 109-28-4. Test between adjacent contacts of mated samples. Perform final reading immediately upon completion of 4 hours conditioning at room ambient.
Dielectric withstanding voltage.	1,500 volts AC at sea level. 1 minute hold with no breakdown or flashover.	AMP Spec 109-29-1. Test between adjacent contacts of mated samples.

Figure 1 (cont)

Test Description	Requirement	Procedure										
MECHANICAL												
Vibration, sinusoidal.	No discontinuities of 10 microseconds or longer duration. See Note.	AMP Spec 109-21-3. Subject mated samples to 10-2000-10 Hz traversed in 20 minutes. 4 hours in each of 3 mutually perpendicular planes. See Figure 3.										
Mechanical shock.	No discontinuities of 10 microseconds or longer duration. See Note.	AMP Spec 109-26-1. Subject mated samples to 50 G's half-sine shock pulses of 11 milliseconds duration. 3 shocks in each direction applied along 3 mutually perpendicular planes, 18 total shocks. See Figure 3.										
Durability.	See Note.	AMP Spec 109-27. Manually mate and unmate samples for 500 cycles at a maximum rate of 600 cycles per hour.										
Mating force.	<table border="1" style="width: 100%; border-collapse: collapse;"> <thead> <tr> <th style="text-align: left;">Shell Size</th> <th style="text-align: center;">Inch Pounds Maximum</th> </tr> </thead> <tbody> <tr> <td style="text-align: center;">11</td> <td style="text-align: center;">5</td> </tr> <tr> <td style="text-align: center;">13</td> <td style="text-align: center;">10</td> </tr> <tr> <td style="text-align: center;">17</td> <td style="text-align: center;">15</td> </tr> <tr> <td style="text-align: center;">23</td> <td style="text-align: center;">20</td> </tr> </tbody> </table>	Shell Size	Inch Pounds Maximum	11	5	13	10	17	15	23	20	AMP Spec 109-42, Condition B. Measure torque necessary to mate samples.
Shell Size	Inch Pounds Maximum											
11	5											
13	10											
17	15											
23	20											
Unmating force.	<table border="1" style="width: 100%; border-collapse: collapse;"> <thead> <tr> <th style="text-align: left;">Shell Size</th> <th style="text-align: center;">Inch Pounds Maximum</th> </tr> </thead> <tbody> <tr> <td style="text-align: center;">11</td> <td style="text-align: center;">5</td> </tr> <tr> <td style="text-align: center;">13</td> <td style="text-align: center;">10</td> </tr> <tr> <td style="text-align: center;">17</td> <td style="text-align: center;">15</td> </tr> <tr> <td style="text-align: center;">23</td> <td style="text-align: center;">20</td> </tr> </tbody> </table>	Shell Size	Inch Pounds Maximum	11	5	13	10	17	15	23	20	AMP Spec 109-42, Condition B. Measure torque necessary to unmate samples.
Shell Size	Inch Pounds Maximum											
11	5											
13	10											
17	15											
23	20											

Figure 1 (cont)

Test Description	Requirement	Procedure
Impact.	See Note.	The sample, wired as intended for normal service, shall be securely fastened to the test fixture in such a manner as to allow the sample to hang freely and rest in Position 1 against the vertical face of Block A, which is a 1½ to 2 inch thick piece of steel that is sufficiently high and wide to ensure that the sample will not strike near the edges of the block. The sample shall be extended its full length from the test fixture to Position 2 and allowed to fall freely by pendulum action to strike Block A. The distance from the fixture to the mating end of the sample shall be 32 inches. There shall be 8 total drops with the radial orientation for each drop dictated by using a different index position of the test fixture. See Figure 4.
ENVIRONMENTAL		
Thermal shock.	See Note.	AMP Spec 109-22. Subject mated samples to 5 cycles between -55 and 105°C.
Humidity-temperature cycling.	See Note.	AMP Spec 109-23-3, Condition B. Subject mated samples to 10 cycles between 25 and 65°C at 95% RH.

NOTE *Shall meet visual requirements, show no physical damage and shall meet requirements of additional tests as specified in Test Sequence in Figure 2.*

Figure 1 (end)

3.6. Product Qualification and Requalification Test Sequence

Test or Examination	Test Group (a)		
	1	2	3
	Test Sequence (b)		
Examination of product	1,7	1,8	1,3
Insulation resistance		2,6	
Dielectric withstanding voltage		3,7	
Vibration	4		
Mechanical shock	5		
Durability	3		
Mating force	2		
Unmating force	6		
Impact			2
Thermal shock		4	
Humidity-temperature cycling		5	

NOTE (a) See paragraph 4.1.A.
 (b) Numbers indicate sequence in which tests are performed.

Figure 2

4. QUALITY ASSURANCE PROVISIONS

4.1. Qualification Testing

A. Sample Selection

Samples shall be prepared in accordance with applicable Instruction Sheets and shall be selected at random from current production. All test groups shall each consist of 5 samples.

B. Test Sequence

Qualification inspection shall be verified by testing samples as specified in Figure 2.

4.2. Requalification Testing

If changes significantly affecting form, fit, or function are made to the product or manufacturing process, product assurance shall coordinate requalification testing, consisting of all or part of the original testing sequence as determined by development/product, quality, and reliability engineering.

4.3. Acceptance

Acceptance is based on verification that the product meets the requirements of Figure 1. Failures attributed to equipment, test setup, or operator deficiencies shall not disqualify the product. When product failure occurs, corrective action shall be taken and samples resubmitted for qualification. Testing to confirm corrective action is required before resubmittal.

4.4. Quality Conformance Inspection

The applicable AMP quality inspection plan will specify the sampling acceptable quality level to be used. Dimensional and functional requirements shall be in accordance with the applicable product drawing and this specification.

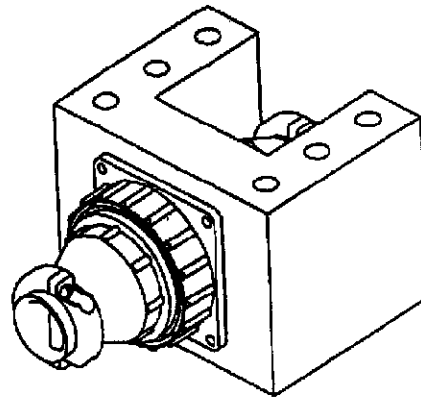

Figure 3
Vibration & Physical Shock Mounting Fixture

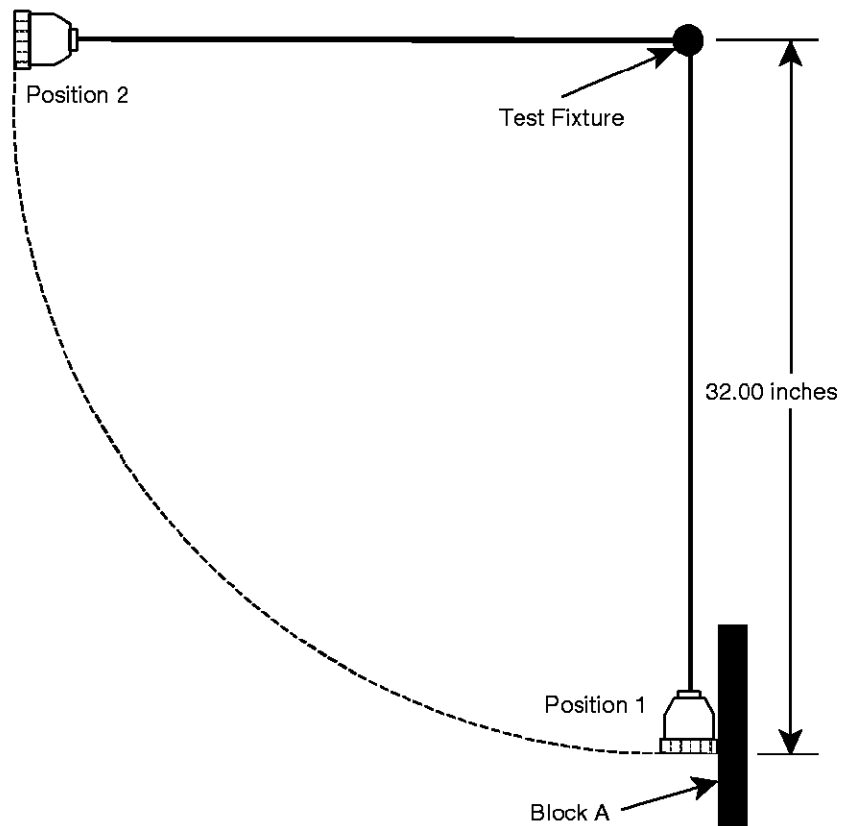

Figure 4
Impact Fixture