



Title	<i>Reference Design Report for a 9.75 W Non-Isolated Buck Power Supply Using LinkSwitch™-TN2Q LNK3209GQ</i>
Specification	30 VDC – 550 VDC Input; 15.0 V / 650 mA Output
Application	Automotive Non-Isolated Bias Supplies
Author	Applications Engineering Department
Document Number	RDR-707Q
Date	August 10, 2022
Revision	1.5

Summary and Features

- Highly integrated solution for low part count and compactness
- >78% full load efficiency at 400 VDC input
- 85°C ambient temperature operation, 105°C with thermal pad to enclosure
- 750 V integrated MOSFET giving 75% derating
- Automotive grade BOM
- No optocoupler
- <60 mW no-load consumption
- <±5% load regulation

PATENT INFORMATION

The products and applications illustrated herein (including transformer construction and circuits external to the products) may be covered by one or more U.S. and foreign patents, or potentially by pending U.S. and foreign patent applications assigned to Power Integrations. A complete list of Power Integrations' patents may be found at www.power.com. Power Integrations grants its customers a license under certain patent rights as set forth at <https://www.power.com/company/intellectual-property-licensing/>.

Power Integrations

5245 Hellyer Avenue, San Jose, CA 95138 USA.
Tel: +1 408 414 9200 Fax: +1 408 414 9201
www.power.com

Table of Contents

1	Introduction.....	4
2	Power Supply Specification.....	5
3	Schematic.....	6
4	Circuit Description	7
4.1	Input Filter.....	7
4.2	Power Stage.....	7
4.3	Output Rectification	8
4.4	Output Feedback	8
4.5	PCB.....	8
5	PCB Layout.....	9
6	Bill of Materials	12
6.1	Electrical BOM	12
6.2	Miscellaneous Mechanical BOM	12
7	Assembly Notes	13
7.1	Inductor L1 Placement	13
7.2	Solder Fill Vias.....	13
8	Design Spreadsheet.....	14
9	Performance Data	16
9.1	Efficiency	16
9.1.1	Line Efficiency.....	16
9.1.2	Load Efficiency.....	17
9.2	No-Load Input Power	18
9.3	Line Regulation	19
9.4	Load Regulation	20
10	Waveforms.....	21
10.1	Load Transient Response	21
10.1.1	15 V Transient 10% - 100% Load Change.....	21
10.1.2	15 V Transient 10% - 50% Load Change	23
10.1.3	15 V Transient 50% - 100% Load Change.....	25
10.2	Switching Waveforms.....	27
10.2.1	Primary MOSFET Drain-Source Voltage and Current at Normal Operation. 27	
10.2.1.1	100% Load CC	27
10.2.1.2	10% Load CC.....	29
10.2.2	Primary MOSFET Drain-Source Voltage and Current at Start-up Operation 31	
10.2.2.1	100% Load CC	31
10.2.2.2	10% Load CC.....	33
10.2.3	Free Wheeling Diode Voltage at Normal Operation.....	35
10.2.3.1	100% Load CC	35
10.2.3.2	10% Load CC.....	37
10.2.4	Free Wheeling Diode Voltage at Start-up.....	39
10.2.4.1	100% Load CC	39
10.2.4.2	10% Load CC.....	41
10.3	Output Start-up	43



10.3.1	Output Start-up 85 °C Ambient.....	43
10.3.2	Output Start-up 25 °C Ambient.....	47
10.3.3	Output Start-up -40 °C Ambient	51
10.4	Fault Conditions.....	55
10.4.1	15 V Output Short-Circuit.....	55
10.5	Output Voltage Ripple.....	57
10.5.1	Ripple Measurement Technique.....	57
10.5.2	Measurement Results	58
10.5.2.1	100% Load Condition	58
10.5.2.2	75% Load Condition	60
10.5.2.3	50% Load Condition	62
10.5.2.4	25% Load Condition	64
10.5.2.5	10% Load Condition	66
10.5.3	15 V Output Ripple Voltage Graph from 0% - 100% with 10% Increment	68
11	Thermal Performance.....	69
11.1	Thermal Performance at Room Temperature.....	69
11.2	Thermal Performance at 85 °C	73
11.3	Thermal Performance at 105 °C with Thermal Pad to Enclosure.....	78
11.3.1	RD-707Q Assembly with Thermal Pad	78
11.3.1.1	Material List	78
11.3.2	RD-707Q Thermal Data at 105 °C	80
12	Revision History	83

Important Note: Although this board is designed to satisfy safety isolation requirements, the engineering prototype has not been agency approved.



1 Introduction

This engineering report describes a buck converter designed to provide a non-isolated nominal output voltage of 15 V at 650 mA load from a wide input voltage range of 30 VDC to 550 VDC. Typical automotive applications include bias supplies for active discharge blocks within on board chargers and traction inverters, pyro disconnect in battery packs, control power for HVAC compressors, PTC auxiliary heaters and body control modules.

This power supply utilizes the LNK3209GQ from the LinkSwitch-TN2Q family of automotive ICs.

This document contains the complete power supply specifications, bill of materials, transformer construction, circuit schematic and printed circuit board layout, along with performance data and electrical waveforms.

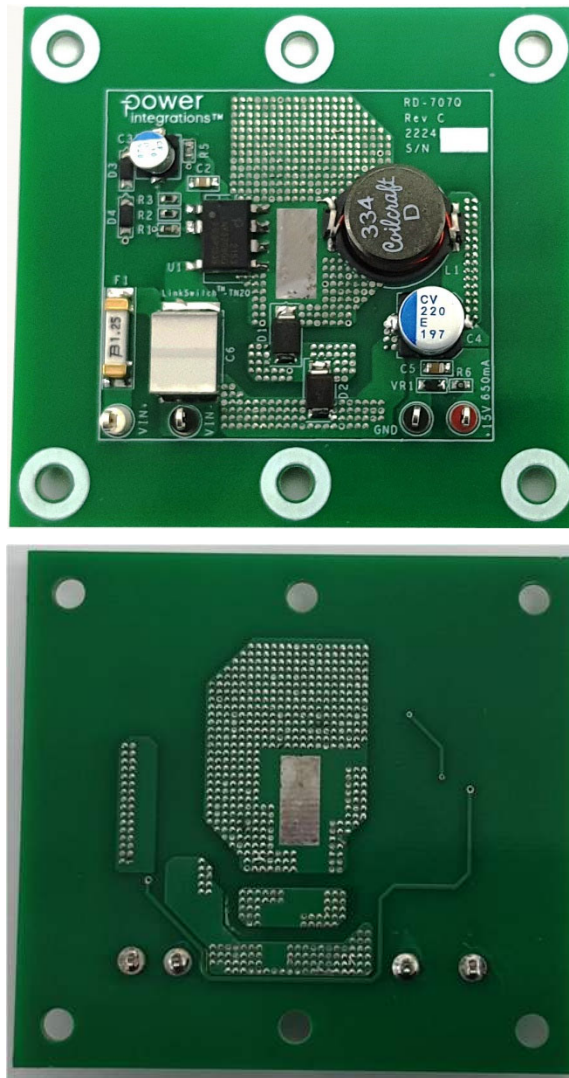

Figure 1 – Populated Circuit Board.

2 Power Supply Specification

The table below represents the minimum acceptable performance of the design. Actual performance is listed in the results section.

Description	Symbol	Min	Typ	Max	Units	Comment
Input						
Voltage	V_{IN}	30		550	V_{DC}	
No-load Input Power				60	mW	400 V_{DC}
Output						
Output Voltage	V_{OUT}	14.25	15	15.75	V	$\pm 5\%$ @ 5% to 100% Load.
Output Ripple Voltage	V_{RIPPLE}			240	mV	20 MHz Bandwidth.
Output Current	I_{OUT}	65		650	mA	
Total Output Power						
Continuous Output Power	P_{OUT}			9.75	W	$V_{IN} = 200 V_{DC}$ to $550 V_{DC}$
Efficiency						
Full Load Efficiency	η	78			%	Measured at 400 V_{DC} , P_{OUT} 25°C.
Environmental						
Ambient Temperature	T_{AMB}	-40		85	°C	Free Convection, Sea Level.

3 Schematic

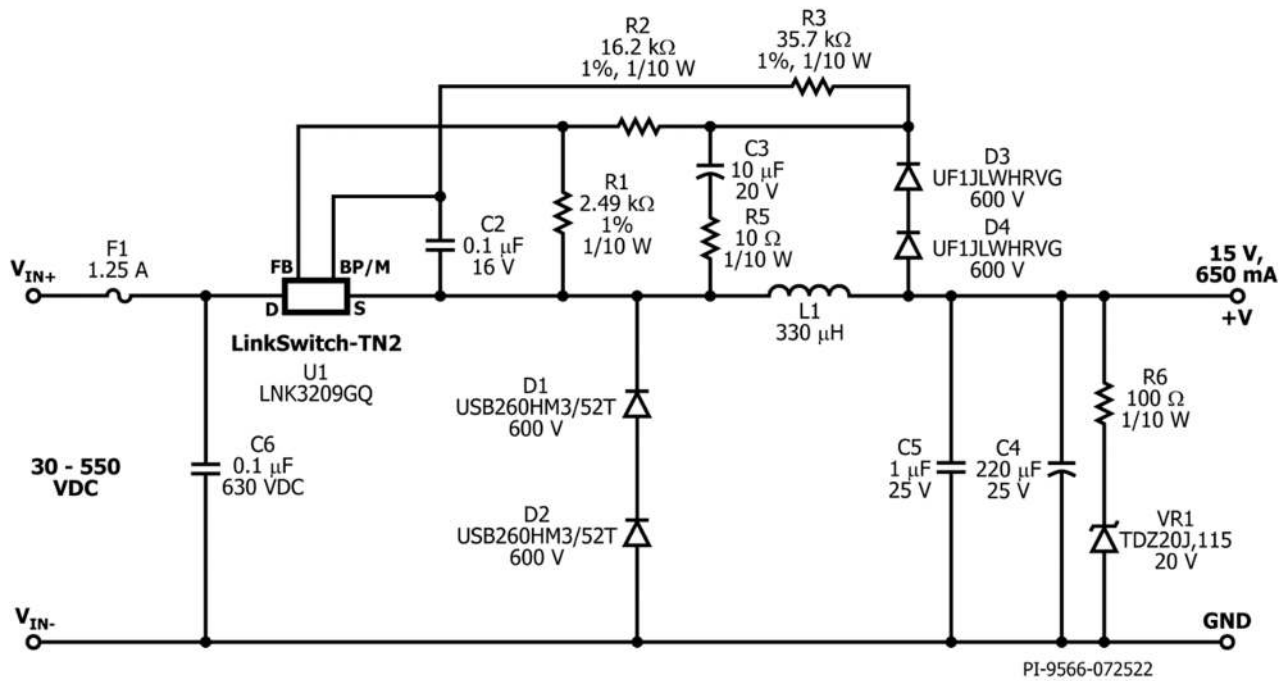

Figure 2 – Schematic.

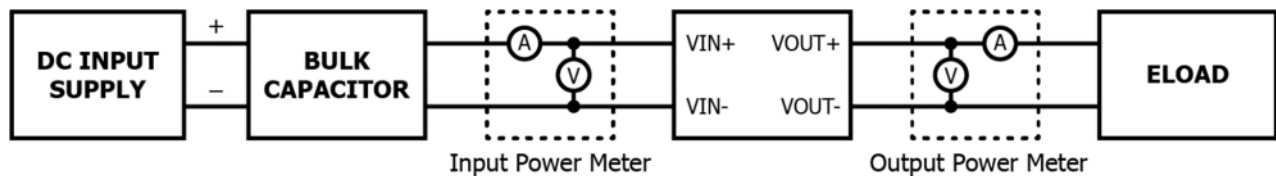

Figure 3 – Test Set-up.

4 Circuit Description

The schematic in Figure 2 shows a buck converter using LNK3209GQ. The circuit provides a non-isolated 15 V, 650 mA continuous output. To simulate the stiff voltage source represented by the vehicle traction battery, bulk capacitors were added to the test set-up as shown in Figure 3.

The LinkSwitch-TN2Q family of ICs for automotive power supplies provide significant reduction in component count compared to traditional discrete solutions. Regulation is achieved using a resistor divider feedback network. The switching frequency jitter feature of the LinkSwitch-TN2Q family and the 66 kHz switching frequency of operation helps reduce EMI. Each device incorporates a 750 V power MOSFET, oscillator, On/Off control, a high-voltage switched current source for self-biasing, frequency jittering, fast (cycle-by-cycle) current limit, hysteretic thermal shutdown, and output overvoltage protection circuitry onto a monolithic IC. LinkSwitch-TN2Q ICs consume very little current in standby resulting in power supply designs that meet <60 mW no-load input at 400 VDC input. A full suite of protection features enables safe and reliable power supplies; protecting the device and the system against device over-temperature faults, lost regulation, and power supply output overload or short-circuit faults.

Being an automotive application, all components selected are AEC-Q compliant.

4.1 *Input Filter*

Fuse F1 isolates the circuit and provides protection from component failure. A bypass capacitor C6 is added to provide a local source for instantaneous switching current. In the final application these components are often already present and may not be required.

4.2 *Power Stage*

The LNK3209GQ device (U1) is configured in a high side buck converter. It is self-starting from the DRAIN (D) pin with local supply decoupling provided by a small 100 nF capacitor C2 connected to the BYPASS (BP/M) pin when input is first applied. During normal operation U1 is powered directly from the output voltage via a current limiting resistor R3

The supply is designed to operate in continuous conduction mode (CCM), with the peak inductor current through L1 set by the LNK3209GQ internal current limit. The on-time for each switching cycle is set by the inductance value of L1, LinkSwitch-TN2Q current limit and the high-voltage across C6. Output regulation is accomplished by skipping switching cycles in response to an ON/OFF feedback signal applied to the FEEDBACK (FB) pin. This differs significantly from traditional PWM schemes that control the duty cycle of each switching cycle. Current into the FB pin greater than 49 μ A will inhibit the switching of the internal power MOSFET, while current below this allows switching cycles to occur.



4.3 **Output Rectification**

During the ON time of U1, current ramps in L1 and is simultaneously delivered to the load. During the OFF time, the inductor current ramps down via free-wheeling diode D1 and D2 into C4 and is delivered to the load. Diode D1 and D2 should be selected as an ultrafast diode (t_{RR} of 35 ns or better is recommended) due to CCM and high ambient temperature operation. High-voltage with low t_{RR} diode are not common. To meet 80% diode voltage derating requirement, two freewheeling diodes in series were implemented. Capacitor C4 should be selected to have an adequate ripple current rating (very low ESR type). Due to the -40°C requirement a solid polymer capacitor was selected. Capacitor C5 provides filtering of the high frequency output voltage ripple.

4.4 **Output Feedback**

During the power MOSFET off-time, capacitor C3 is charged to the output voltage via D3 and D4. This voltage is used to provide feedback to the IC via the resistor divider formed by resistors R1 and R2. The FEEDBACK (FB) pin is then sampled by the controller inside U1 at the beginning of a switching cycle. A current greater than 49 μ A into the FB pin will inhibit the switching of the internal power MOSFET while a current below will allow the switching cycle to occur. To meet 80% voltage derating requirement of the feedback diode, two diodes in series were employed. To improve output ripple, R5 is placed in series with sample and hold cap C3

4.5 **PCB**

Printed Circuit Board (PCB) should be rigid enough to survive the harsh environment of automotive application. FR-4 High Tg PCB material was used in the design.



5 PCB Layout

Layers: Four (4)
 Board Material: FR4 (TG 170)
 Board Thickness: 1.6 mm
 Copper Weight: 2 oz

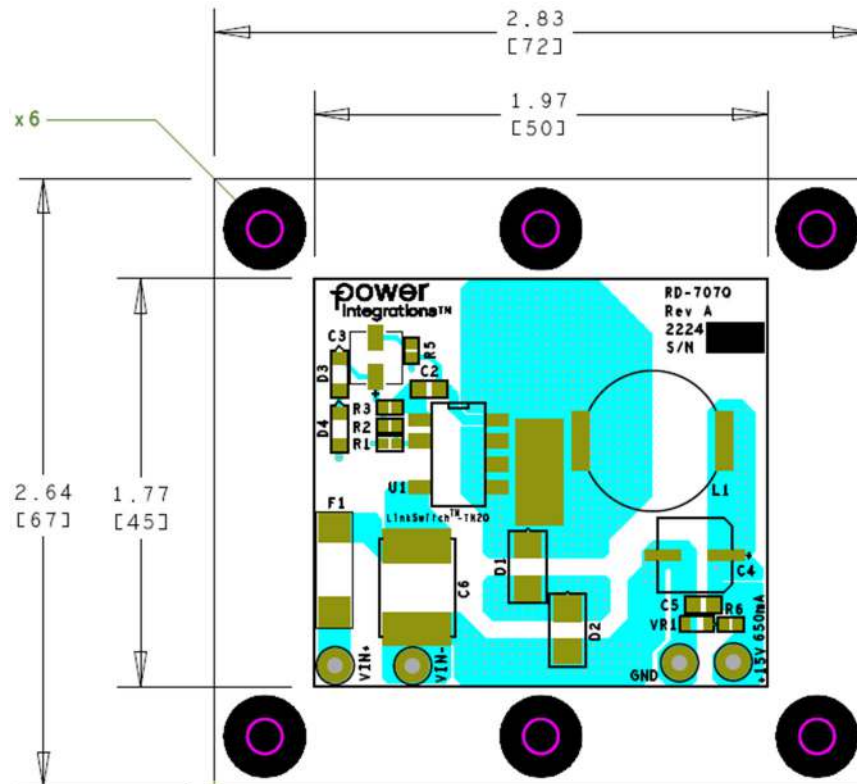

Figure 4 – Printed Circuit Board, Top View.

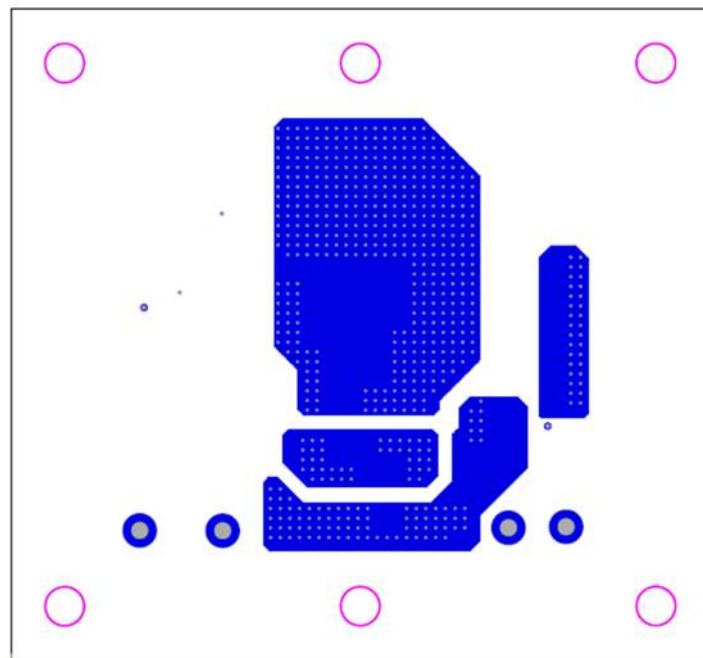

Figure 5 – Printed Circuit Board, Layer 2 View.

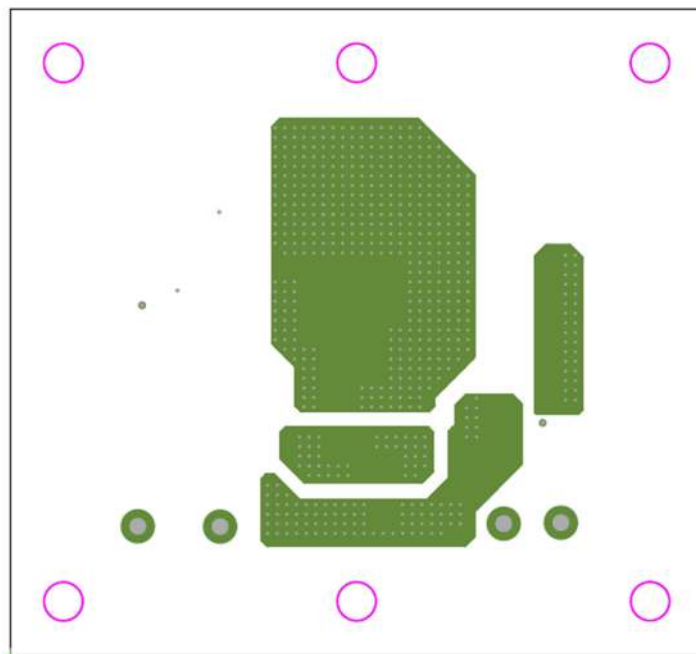

Figure 6 – Printed Circuit Board, Layer 3 View.

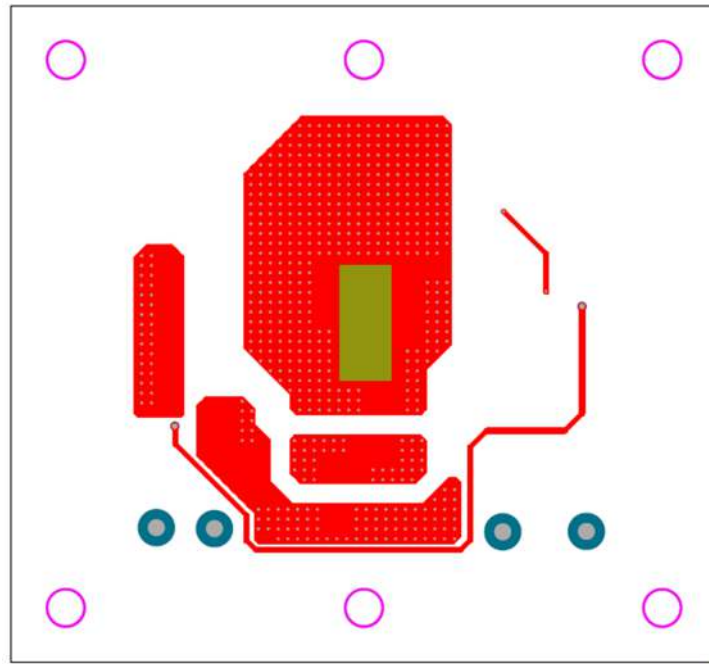

Figure 7 – Printed Circuit Board, Bottom View.

6 Bill of Materials

6.1 Electrical BOM

Item	Qty	Ref Des	Description	Mfg Part Number	Mfg
1	1	C2	0.1 μ F \pm 10% 16 V Ceramic X7R 0805	C0805C104K4RECAUTO	KEMET
2	1	C3	10 μ F, \pm 20%, 20 V, Aluminum - Polymer, 0.209" L x 0.209" W (5.30 mm x 5.30 mm) x Height 0.236" (6.00 mm), SMD	PCF1D100MCL1GS	Nichicon
3	1	C4	220 μ F, \pm 20%, 25 V, Aluminum - Polymer, 0.327" L x 0.327" W (8.30 mm x 8.30 mm) x Height 0.472" (12.00 mm), SMD	PCV1E221MCL2GS	Nichicon
4	1	C5	1 μ F, \pm 10%, 25 V, Ceramic, X7R, 0805	08053C105K4T2A	AVX
5	1	C6	0.1 μ F, \pm 10%, 630 VDC, 200 VAC, Polyester, Polyethylene Naphthalate (PEN) Film, Stacked, 4030, -55°C ~ 125°C	LDEPF3100KA0N00	KEMET
6	2	D1 D2	Diode, Ultrafast Recovery, 600 V, 2 A, SMT, DO-214AA (SMB), DO214AA (SMB)(SMBJ)	USB260HM3/52T	Vishay
7	2	D3 D4	Diode, General Purpose, 600 V, 1 A, SMT, CFP3, SOD-123W	UF1JLWHRVG	Taiwan Semi
8	1	F1	FUSE, 1.25 A, 600 VAC, SLOW, 2SMD	SF-3812TM125T-2	Bourns Inc.
9	1	L1	Fixed Inductors, 330 μ H, Unshld, \pm 10%, 1.5 A, 325 m Ω	DO5040H-334KLD	Coilcraft
10	1	R1	RES, 2.49 k Ω , 1%, 1/10 W, Thick Film, 0603	ERJ-3EKF2491V	Panasonic
11	1	R2	RES, 16.2 k Ω , 1%, 1/10 W, Thick Film, 0603	ERJ-3EKF1622V	Panasonic
12	1	R3	RES, 35.7 k Ω , 1%, 1/10 W, Thick Film, 0603	ERJ-3EKF3572V	Panasonic
13	1	R5	RES, 10 Ω , 5%, 1/10 W, Thick Film, 0603	ERJ-3GEYJ100V	Panasonic
14	1	R6	RES, 100 Ω , 5%, 1/10 W, Thick Film, 0603	ERJ-3GEYJ101V	Panasonic
15	1	U1	LinkSwitch-TN2Q, SMD-8C	LNK3209GQ	Power Integrations
16	1	VR1	Zener Diode, 20 V, 500 mW, \pm 2%, Surface Mount SOD323F, SC-90, SOD-323F	TDZ20J,115	Nexperia USA Inc.

6.2 Miscellaneous Mechanical BOM

Item	Qty	Ref Des	Description	Mfg	Mfg Part Number
1	1	+V	Test Point, RED, THRU-HOLE MOUNT	5010	Keystone
2	2	GND VIN-	Test Point, BLK, THRU-HOLE MOUNT	5011	Keystone
3	1	VIN+	Test Point, WHT, THRU-HOLE MOUNT	5012	Keystone



7 Assembly Notes

7.1 Inductor L1 Placement

Output inductor placement L1 should be placed according to the picture below. The body marking side "334" should be on the SOURCE trace. While body marking "D" should be on the output side trace.

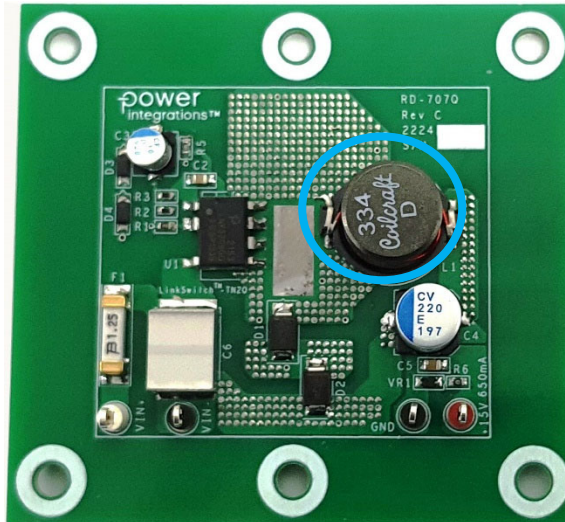

Figure 8 – Output Inductor L1 Placement.

7.2 Solder Fill Vias

Manual Solder fill the vias (enclosed in the box below). This will help to improve thermal performance of RD-707Q.

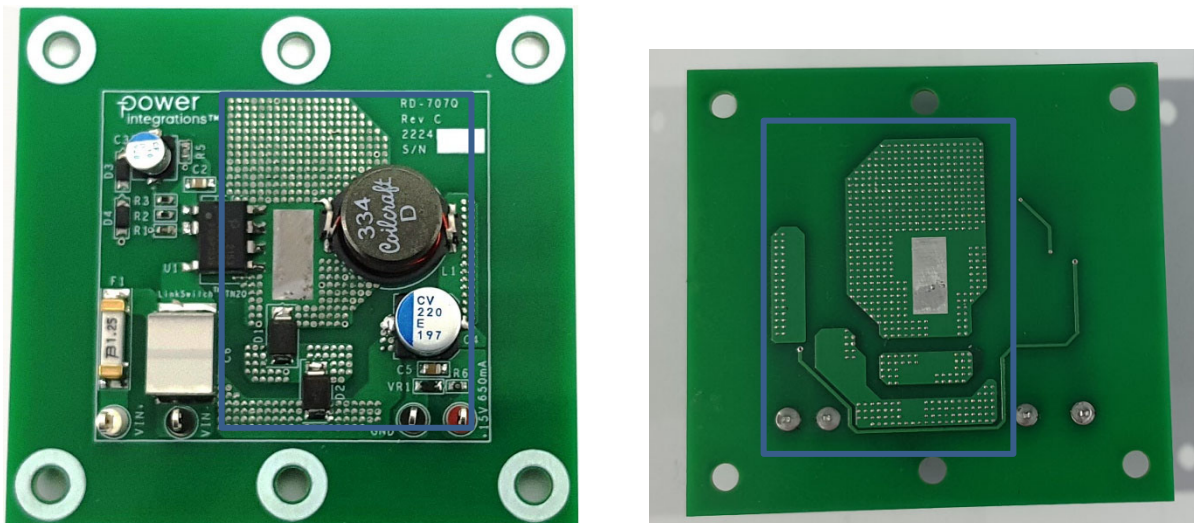

Figure 9 – Vias with Solder to Improve Performance.

8 Design Spreadsheet

DCDC_LinkSwitchTN2-Automotive-Buck_092421; Rev.1.2; Copyright Power Integrations 2021	INPUT	INFO	OUTPUT	UNIT	DCDC LinkSwitchTN2-Automotive Buck
ENTER APPLICATION VARIABLES					
VDCMIN	30.00		30.00	V	Minimum DC voltage
VDCMAX	550.00		550.00	V	Maximum DC input voltage
VOUT	15.00		15.00	V	Output voltage
IOUT	0.650		0.650	A	Average output current
EFFICIENCY_ESTIMATED			0.80		Efficiency estimate at output terminals
EFFICIENCY_CALCULATED			0.68		Calculated efficiency based on real components and operating point
POUT			9.75	W	Continuous output power
INPUT STAGE RESISTANCE			10	Ohms	Input stage resistance in ohms (includes thermistor, filtering components, etc)
PLOSS_INPUTSTAGE			1.650	W	Maximum input stage loss
ENTER LINKSWITCH-TN2-AUTOMOTIVE VARIABLES					
OPERATION MODE			MCM		Mostly continuous mode of operation
CURRENT LIMIT MODE	STD		STD		Choose 'RED' for reduced current limit or 'STD' for standard current limit
PACKAGE			SMD-8C		Select the device package
DEVICE SERIES	LNK3209		LNK3209		Generic LinkSwitch-TN2 device
DEVICE CODE			LNK3209GQ		Required LinkSwitch-TN2 device
ILIMITMIN			1.200	A	Minimum current limit of the device
ILIMITTYP			1.300	A	Typical current limit of the device
ILIMITMAX			1.400	A	Maximum current limit of the device
RDSON			3.20	ohms	Primary switch on-time drain to source resistance at 125degC
FSDSON			62000	Hz	Minimum switching frequency
FSTYP			66000	Hz	Typical switching frequency
FSDMAX			70000	Hz	Maximum switching frequency
BVDSS			750	V	Device breakdown voltage
PRIMARY SWITCH PARAMETERS					
VSDSON			2.00	V	Primary switch on-time drain to source voltage estimate
VSDSOFF			578	V	Primary switch off-time drain-to-source voltage stress
DUTY			0.574		Maximum duty cycle
TIME_ON_MIN			0.857	us	Primary switch minimum on-time
IPED_PRIMARYSWITCH			0.127	A	Maximum primary switch pedestal current
IRMS_PRIMARYSWITCH			0.579	A	Maximum primary switch RMS current
PLOSS_PRIMARYSWITCH			1.096	W	Maximum primary switch loss
BUCK INDUCTOR PARAMETERS					
INDUCTANCE_MIN			297	uH	Minimum design inductance required for current delivery. Note that the chosen inductor must be AEC-Q200 compliant
INDUCTANCE_TYP	AUTO		330	uH	Typical design inductance required for current delivery. Note that the chosen inductor must be AEC-Q200 compliant
INDUCTANCE_MAX			363	uH	Maximum design inductance required for current delivery. Note that the chosen inductor must be AEC-Q200 compliant
TOLERANCE_INDUCTANCE			10	%	Tolerance of the design inductance
DC RESISTANCE OF INDUCTOR			2.0	ohms	DC resistance of the buck inductor
FACTOR_KLOSS			0.50		Factor that accounts for "off-state" power loss to be supplied by inductor (usually between 50% to 66%)
IRMS_INDUCTOR			0.949	A	Maximum inductor RMS current
PLOSS_INDUCTOR			1.800	W	Maximum inductor losses



FREEWHEELING DIODE PARAMETERS					
VF_FREEWHEELING			2.50	V	Forward voltage drop across the two freewheeling diodes in series
PIV_RATING			600.00	V	Peak inverse voltage rating of each freewheeling diode
TRR			25	ns	Reverse recovery time of each freewheeling diode
PIV_CALCULATED			578	V	Computed peak inverse voltage across the freewheeling diodes
IRMS_DIODE			0.934	A	Maximum diode RMS current
PLOSS_DIODE			1.707	W	Maximum loss across both freewheeling diodes
RECOMMENDED DIODE	UF1JLW		UF1JLW		Recommended freewheeling diode. Two of this diode in series must be implemented to pass 80% voltage derating and thermal requirements
BIAS/FEEDBACK PARAMETERS					
VF_BIAS			0.70	V	Forward voltage drop of the bias diode
RBIAS			2490	Ohms	Bias resistor
CBP			0.1	uF	BP pin capacitor
RFB			17400	Ohms	Feedback resistor
CFB			10	uF	Feedback capacitor
C_SOFTSTART			1-10	uF	If the output voltage is greater than 12 V or total output and system capacitance is greater than 100 uF, a soft start capacitor between 1uF and 10 uF is recommended
PLOSS_FEEDBACK			0.011	W	Maximum feedback component losses
OUTPUT CAPACITOR					
OUTPUT VOLTAGE RIPPLE			300	mV	Desired output voltage ripple
IRMS_COUT			0.691	A	Maximum output capacitor RMS current
PLOSS_COUT			0.137	W	Maximum output capacitor power loss
ESR_COUT			287	mOhms	ESR of the output capacitor

Note: Freewheeling diode PIV was addressed by using two diodes in series. The design requires a low t_{RR} diode but high-voltage with low t_{RR} diode is not common. To meet the diode's PIV and low t_{RR} requirement, two freewheeling diodes in series was implemented.



9 Performance Data

9.1 Efficiency

9.1.1 Line Efficiency

Test Condition: Soak for 10 minutes for each line and 1 minute integration time.

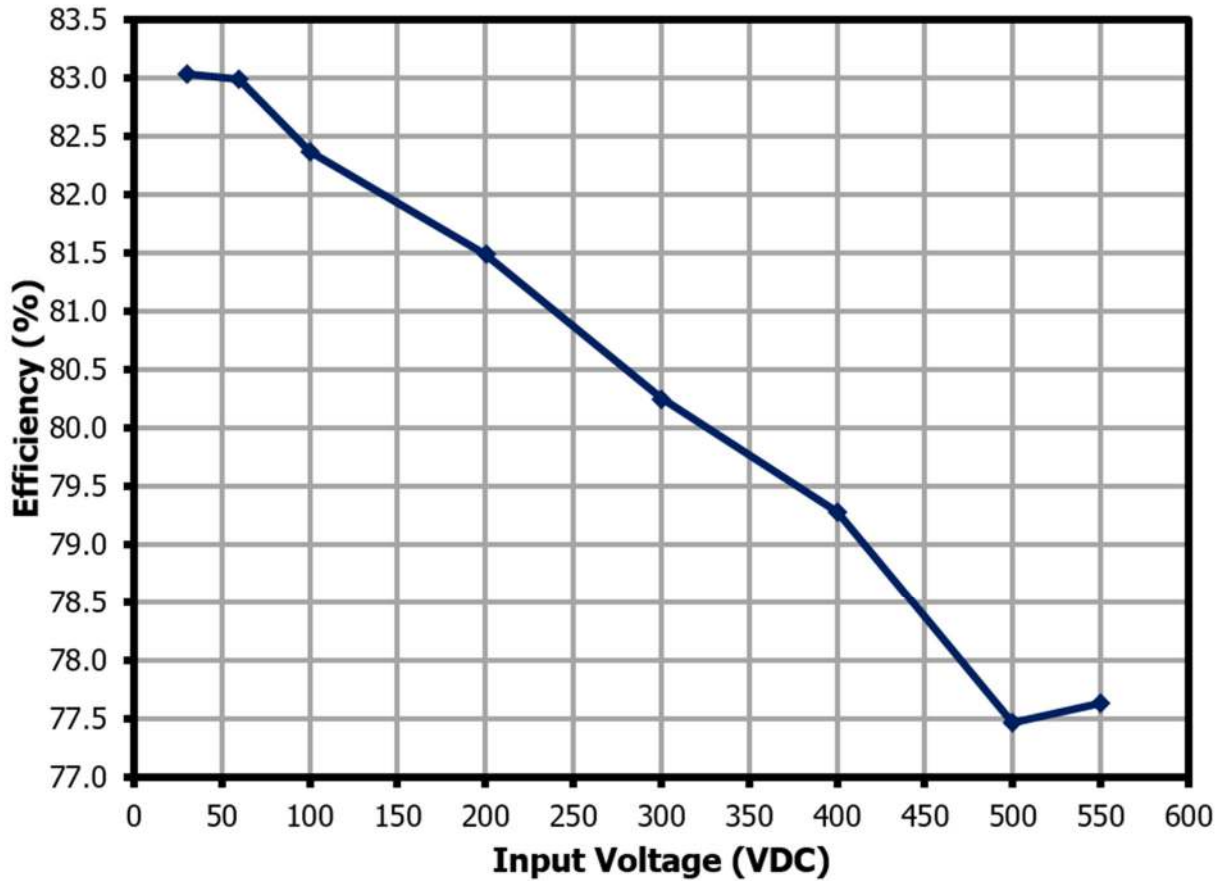

Figure 10 – Efficiency vs. Input Voltage.

9.1.2 Load Efficiency

Test Condition: Soak for 10 minutes, 5 minutes delay for each line, 10 s delay for each load, and 1 minute integration time.

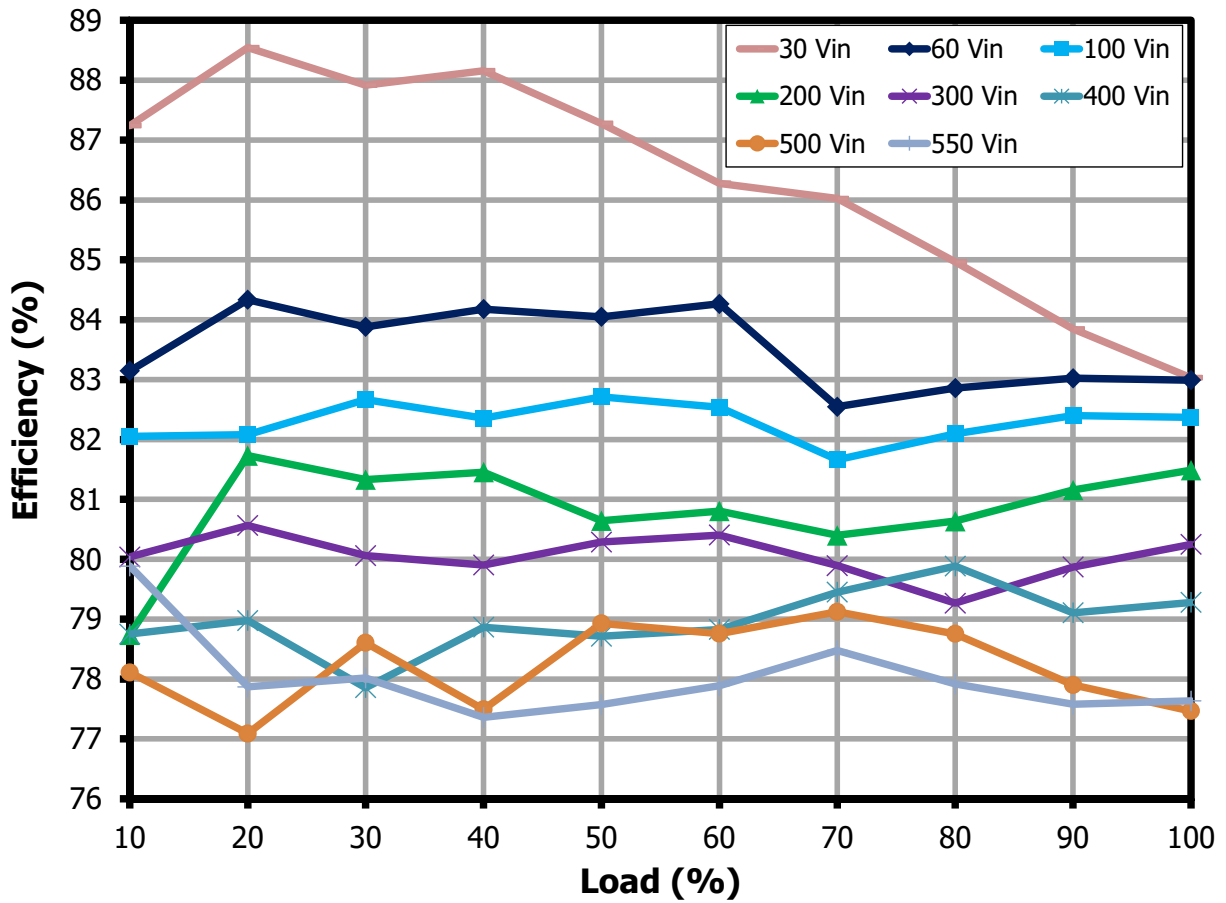

Figure 11 – Efficiency vs. Percentage Load.

9.2 *No-Load Input Power*

Test Condition: Soak for 10 minutes for each line and 1 minute integration time.

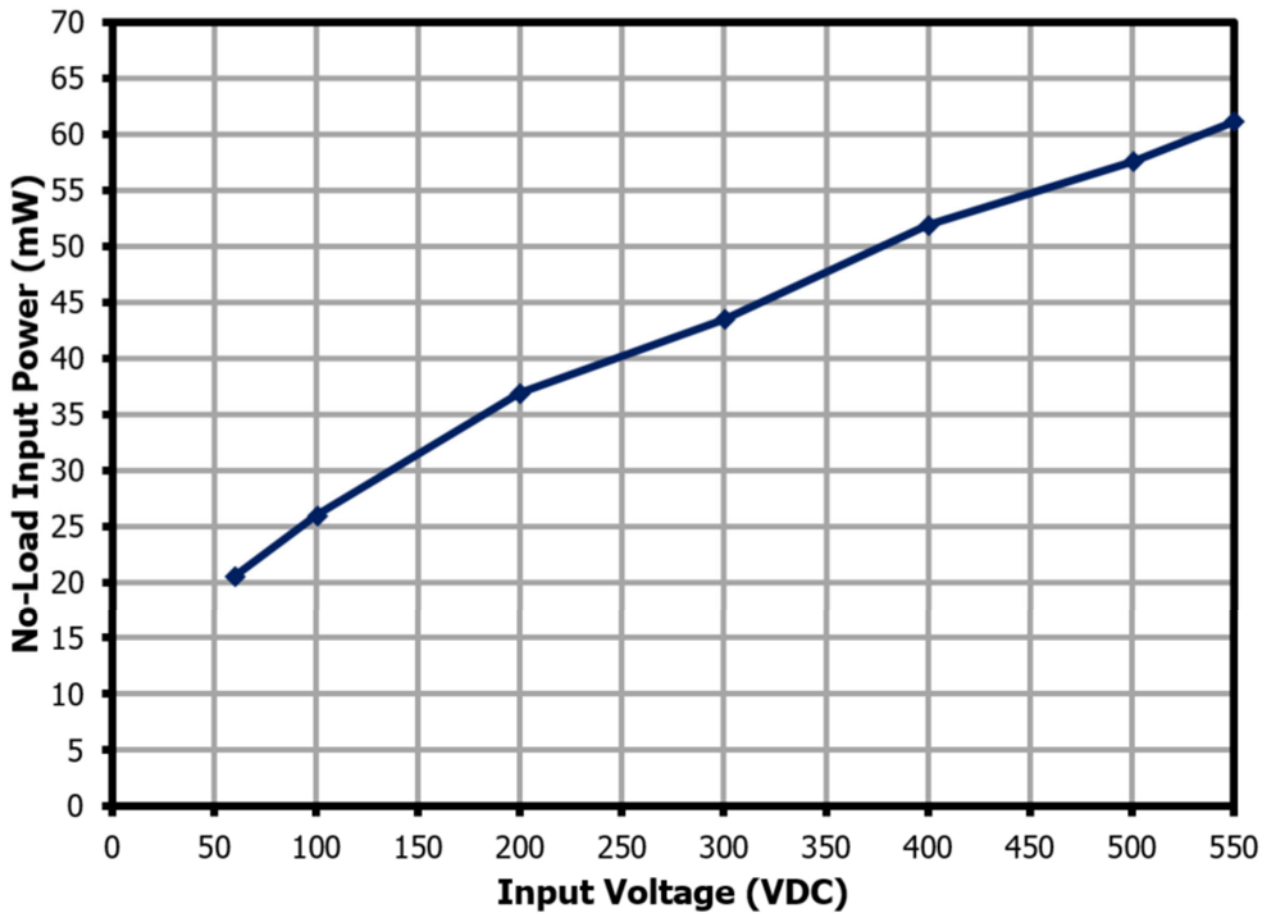

Figure 12 – No-Load Input Power vs. Line at Room Temperature.

9.3 Line Regulation

Test Condition: Soak for 10 minutes for each line and 1 minute integration time.

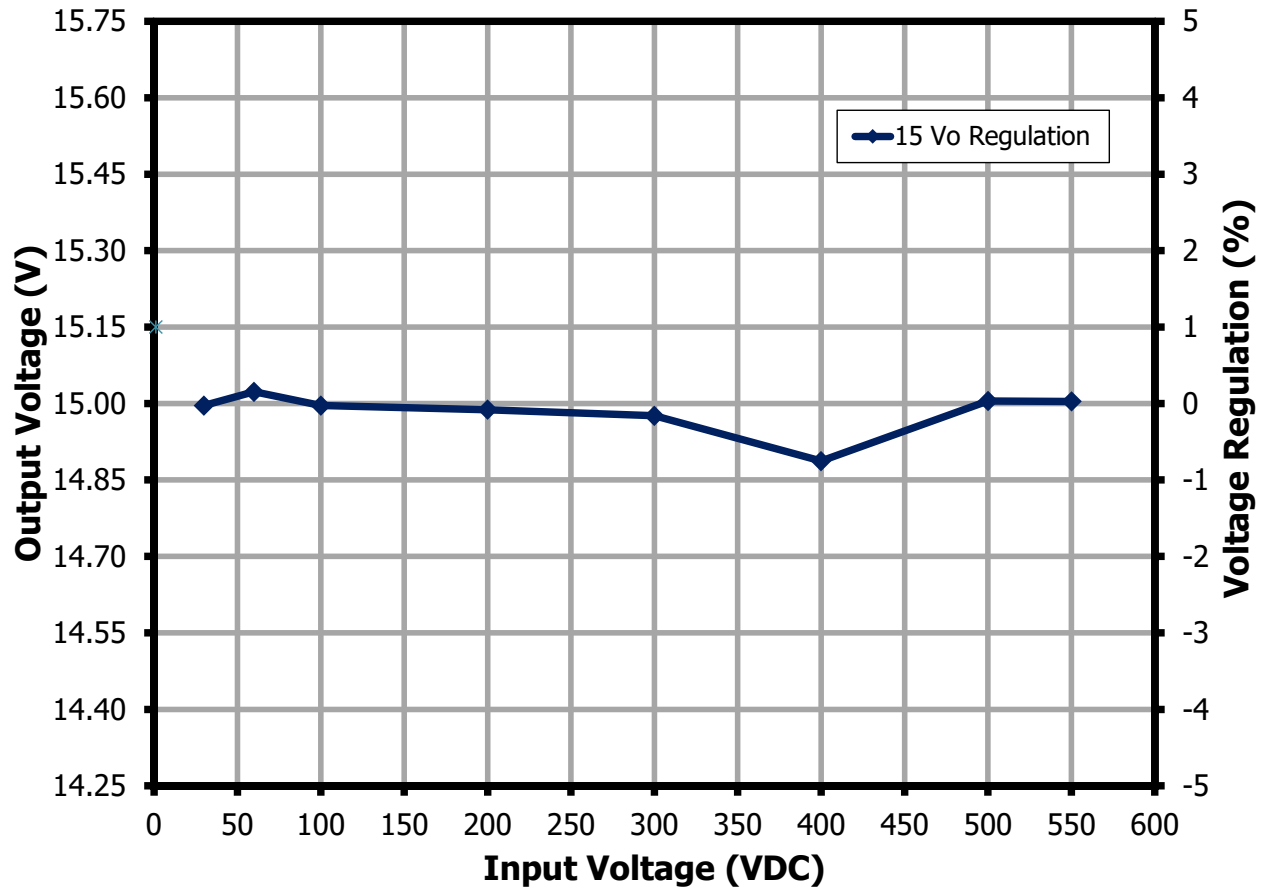

Figure 13 – Output Voltage vs. Line Voltage.

9.4 Load Regulation

Test Condition: Soak for 10 minutes, 5 minutes delay per each line, 10 s delay for each load, and 1 minute integration time.

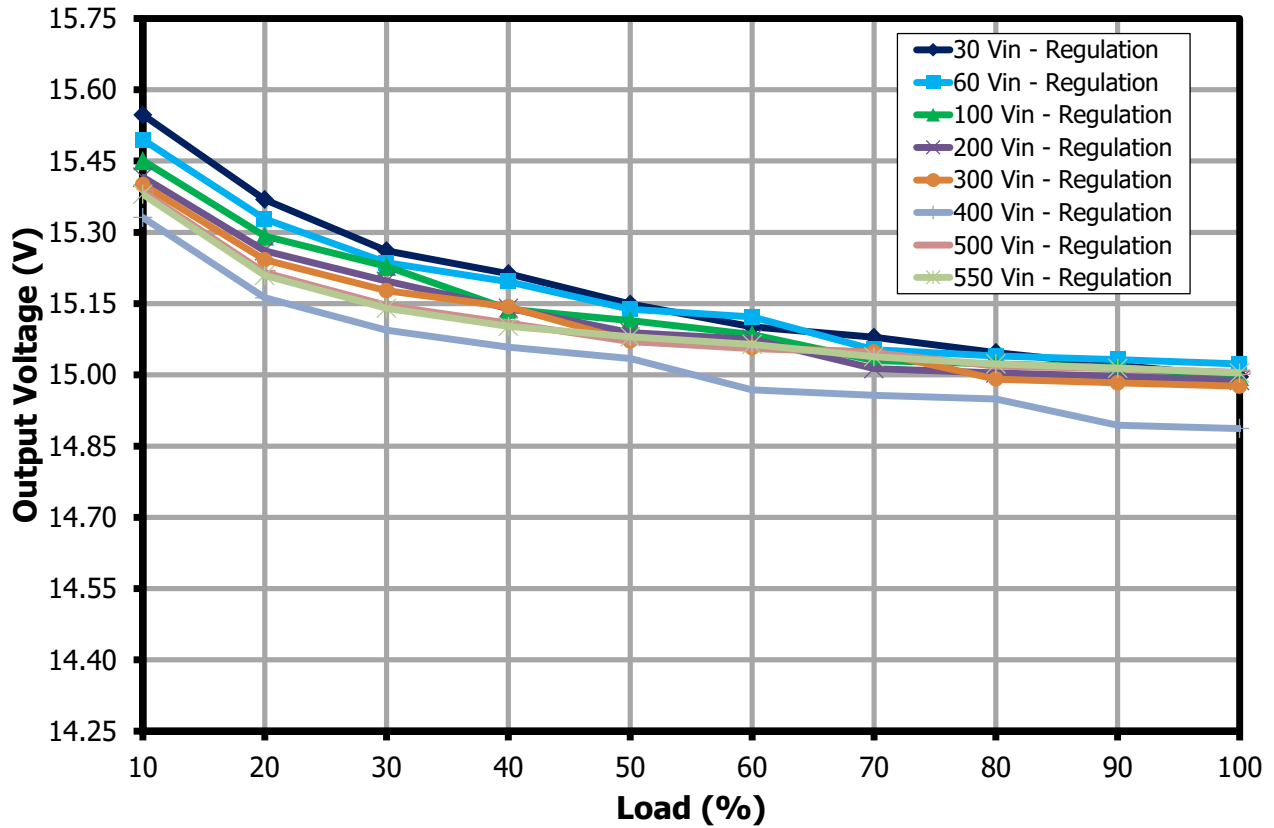

Figure 14 – Output Voltage vs. Percent Load.

10 Waveforms

10.1 Load Transient Response

Test Condition: Dynamic load frequency = 100 Hz, Duty cycle = 50 %
Slew Rate = 0.8 A / μ s

10.1.1 15 V Transient 10% - 100% Load Change

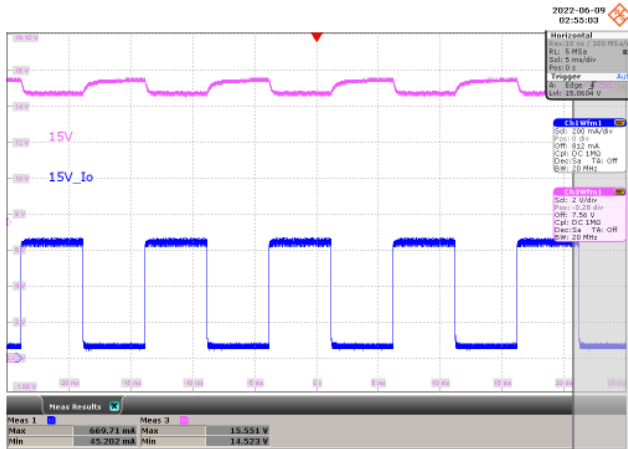

Figure 15 – 30 VDC Input.
CH1: I_{OUT}, 200 mA / div., 5 ms / div.
CH3: V_{OUT}, 2 V / div., 5 ms / div.
V_{OUT}(MAX) = 15.551 V, V_{OUT}(MIN) = 14.523 V.



Figure 16 – 60 VDC Input.
CH1: I_{OUT}, 200 mA / div., 5 ms / div.
CH3: V_{OUT}, 2 V / div., 5 ms / div.
V_{OUT}(MAX) = 15.709 V, V_{OUT}(MIN) = 14.839 V.

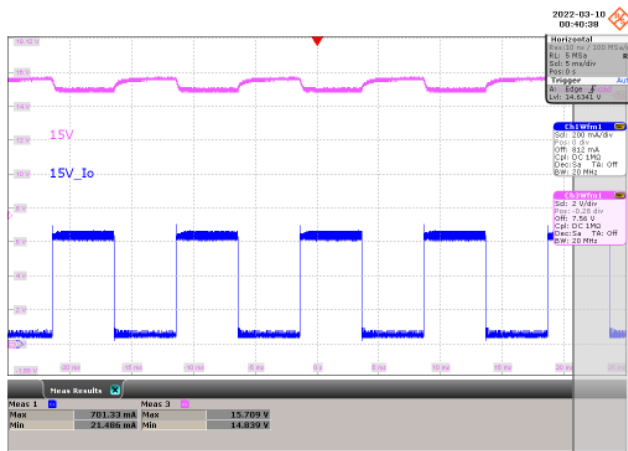

Figure 17 – 100 VDC Input.
CH1: I_{OUT}, 200 mA / div., 5 ms / div.
CH3: V_{OUT}, 2 V / div., 5 ms / div.
V_{OUT}(MAX) = 15.709 V, V_{OUT}(MIN) = 14.839 V.

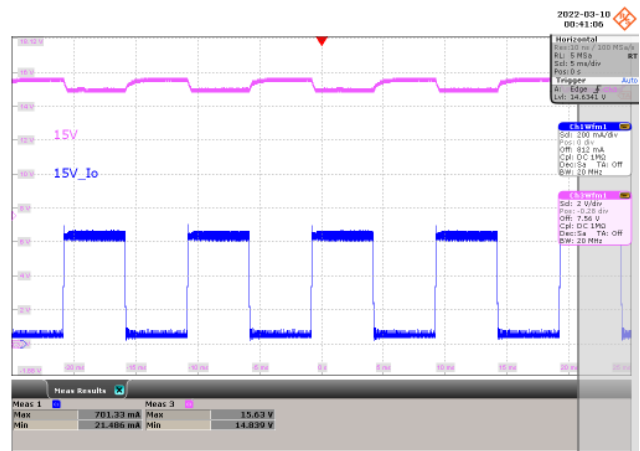

Figure 18 – 200 VDC Input.
CH1: I_{OUT}, 200 mA / div., 5 ms / div.
CH3: V_{OUT}, 2 V / div., 5 ms / div.
V_{OUT}(MAX) = 15.63 V, V_{OUT}(MIN) = 14.839 V.

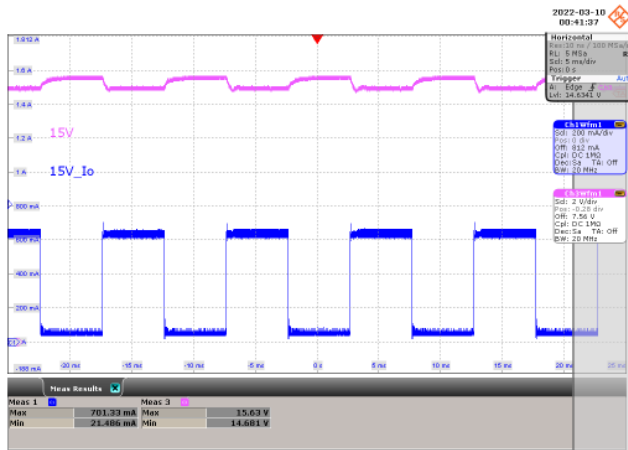

Figure 19 – 300 VDC Input.
 CH1: I_{OUT}, 200 mA / div., 5 ms / div.
 CH3: V_{OUT}, 2 V / div., 5 ms / div.
 V_{OUT}(MAX) = 15.63 V, V_{OUT}(MIN) = 14.681 V



Figure 20 – 400 VDC Input.
 CH1: I_{OUT}, 200 mA / div., 5 ms / div.
 CH3: V_{OUT}, 2 V / div., 5 ms / div.
 V_{OUT}(MAX) = 15.63 V, V_{OUT}(MIN) = 14.681 V.

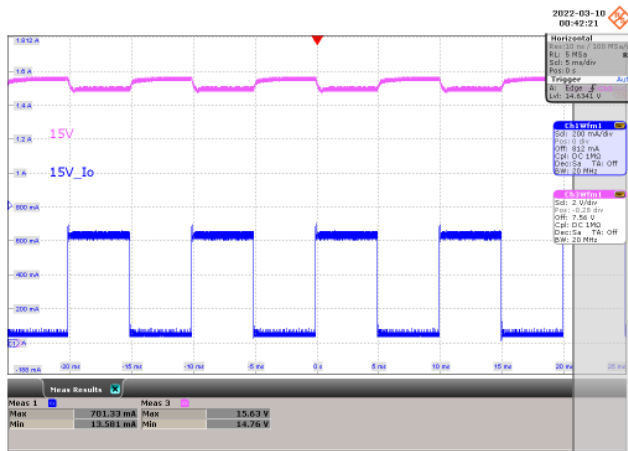

Figure 21 – 500 VDC Input.
 CH1: I_{OUT}, 200 mA / div., 5 ms / div.
 CH3: V_{OUT}, 2 V / div., 5 ms / div.
 V_{OUT}(MAX) = 15.63 V, V_{OUT}(MIN) = 14.76 V.



Figure 22 – 550 VDC Input.
 CH1: I_{OUT}, 200 mA / div., 5 ms / div.
 CH3: V_{OUT}, 2 V / div., 5 ms / div.
 V_{OUT}(MAX) = 15.63 V, V_{OUT}(MIN) = 14.681 V.

10.1.2 15 V Transient 10% - 50% Load Change

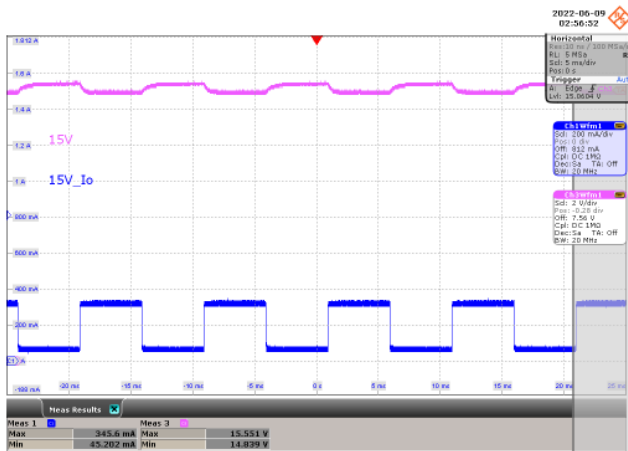

Figure 23 – 30 VDC Input.
 CH1: I_{OUT}, 200 mA / div., 5 ms / div.
 CH3: V_{OUT}, 2 V / div., 5 ms / div.
 V_{OUT(MAX)} = 15.551 V, V_{OUT(MIN)} = 14.839 V.

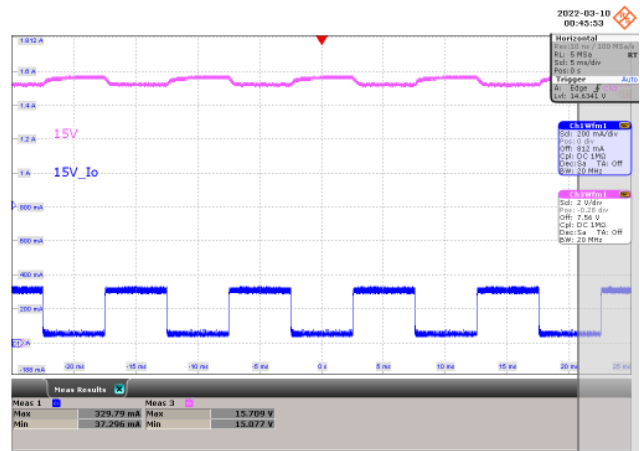

Figure 24 – 60 VDC Input.
 CH1: I_{OUT}, 200 mA / div., 5 ms / div.
 CH3: V_{OUT}, 2 V / div., 5 ms / div.
 V_{OUT(MAX)} = 15.709 V, V_{OUT(MIN)} = 15.077 V.

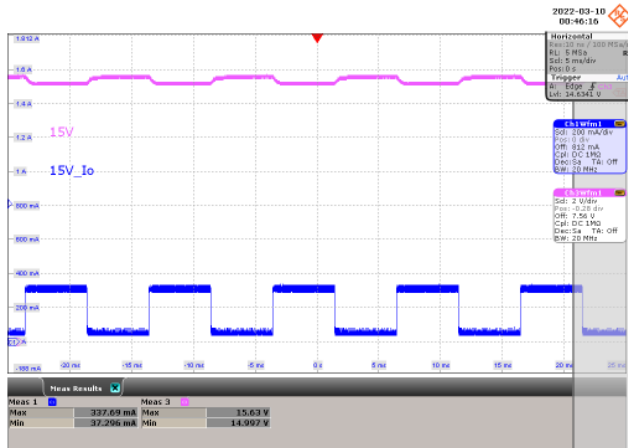

Figure 25 – 100 VDC Input.
 CH1: I_{OUT}, 200 mA / div., 5 ms / div.
 CH3: V_{OUT}, 2 V / div., 5 ms / div.
 V_{OUT(MAX)} = 15.63 V, V_{OUT(MIN)} = 14.997 V.

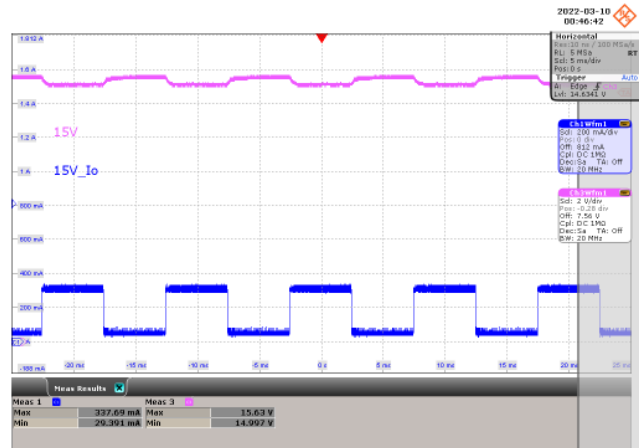

Figure 26 – 200 VDC Input.
 CH1: I_{OUT}, 200 mA / div., 5 ms / div.
 CH3: V_{OUT}, 2 V / div., 5 ms / div.
 V_{OUT(MAX)} = 15.63 V, V_{OUT(MIN)} = 14.997 V.

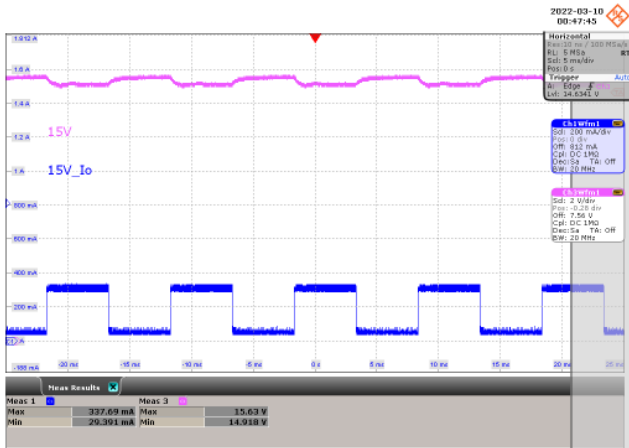

Figure 27 – 300 VDC Input.
 CH1: I_{OUT}, 200 mA / div., 5 ms / div.
 CH3: V_{OUT}, 2 V / div., 5 ms / div.
 V_{OUT}(MAX) = 15.63 V, V_{OUT}(MIN) = 14.918 V.

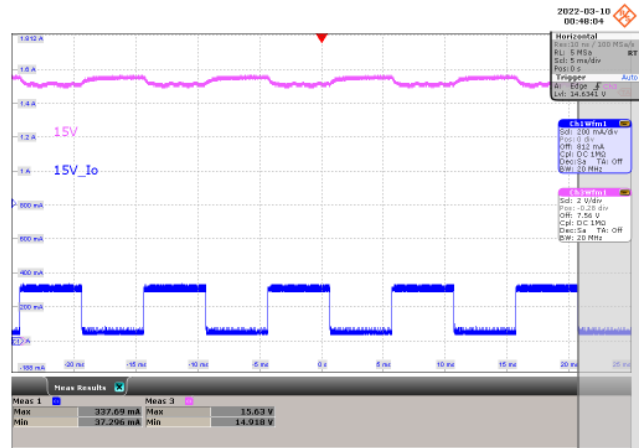

Figure 28 – 400 VDC Input.
 CH1: I_{OUT}, 200 mA / div., 5 ms / div.
 CH3: V_{OUT}, 2 V / div., 5 ms / div.
 V_{OUT}(MAX) = 15.63 V, V_{OUT}(MIN) = 14.918 V.

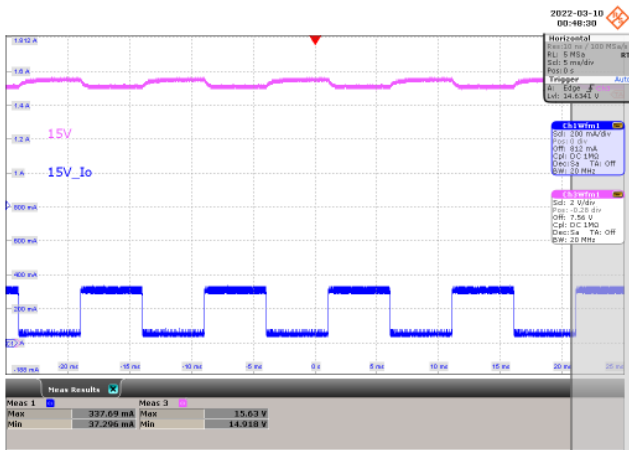

Figure 29 – 500 VDC Input.
 CH1: I_{OUT}, 200 mA / div., 5 ms / div.
 CH3: V_{OUT}, 2 V / div., 5 ms / div.
 V_{OUT}(MAX) = 15.63 V, V_{OUT}(MIN) = 14.918 V.

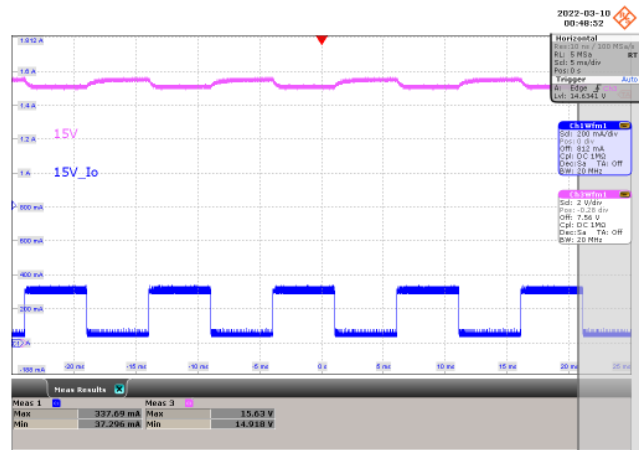

Figure 30 – 550 VDC Input.
 CH1: I_{OUT}, 200 mA / div., 5 ms / div.
 CH3: V_{OUT}, 2 V / div., 5 ms / div.
 V_{OUT}(MAX) = 15.63 V, V_{OUT}(MIN) = 14.918 V.

10.1.3 15 V Transient 50% - 100% Load Change

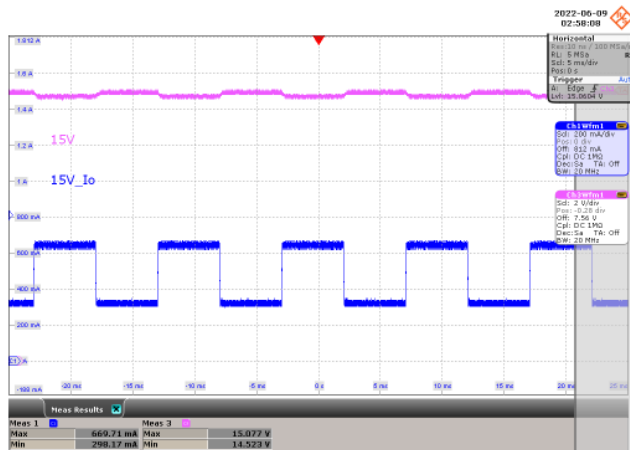

Figure 31 – 30 VDC Input.
 CH1: I_{OUT}, 200 mA / div., 5 ms / div.
 CH3: V_{OUT}, 2 V / div., 5 ms / div.
 V_{OUT}(MAX) = 15.077 V, V_{OUT}(MIN) = 14.523 V.



Figure 32 – 60 VDC Input.
 CH1: I_{OUT}, 200 mA / div., 5 ms / div.
 CH3: V_{OUT}, 2 V / div., 5 ms / div.
 V_{OUT}(MAX) = 15.314 V, V_{OUT}(MIN) = 14.839 V.

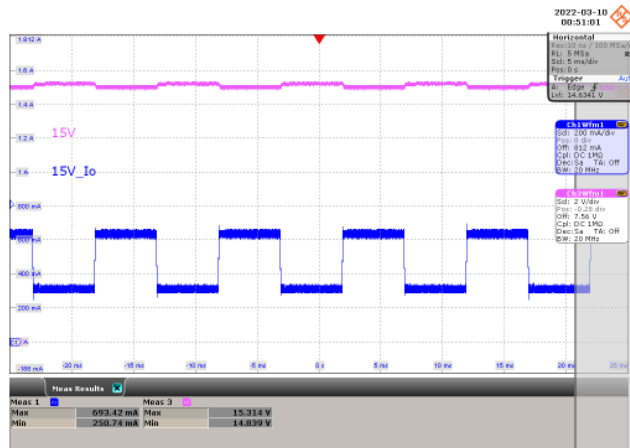

Figure 33 – 100 VDC Input.
 CH1: I_{OUT}, 200 mA / div., 5 ms / div.
 CH3: V_{OUT}, 2 V / div., 5 ms / div.
 V_{OUT}(MAX) = 15.314 V, V_{OUT}(MIN) = 14.839 V.

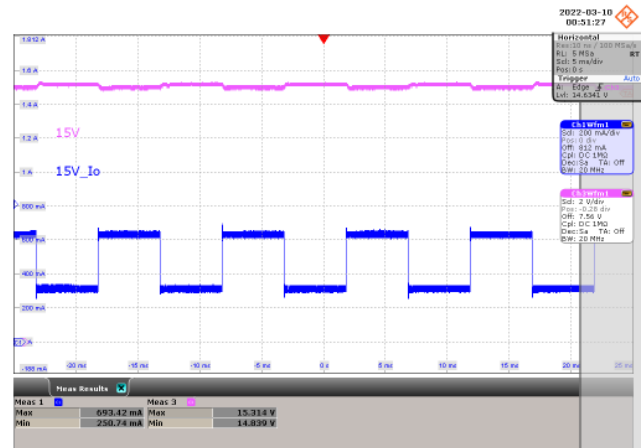

Figure 34 – 200 VDC Input.
 CH1: I_{OUT}, 200 mA / div., 5 ms / div.
 CH3: V_{OUT}, 2 V / div., 5 ms / div.
 V_{OUT}(MAX) = 15.314 V, V_{OUT}(MIN) = 14.839 V.

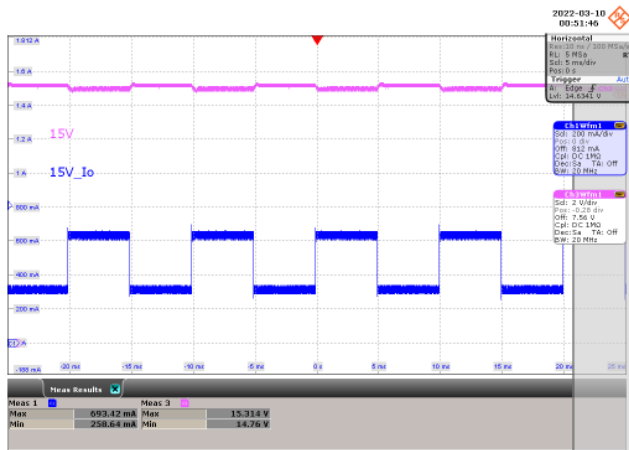

Figure 35 – 300 VDC Input.
 CH1: I_{OUT} , 200 mA / div., 5 ms / div.
 CH3: V_{OUT} , 2 V / div., 5 ms / div.
 $V_{OUT(MAX)} = 15.314\text{ V}$, $V_{OUT(MIN)} = 14.76\text{ V}$.

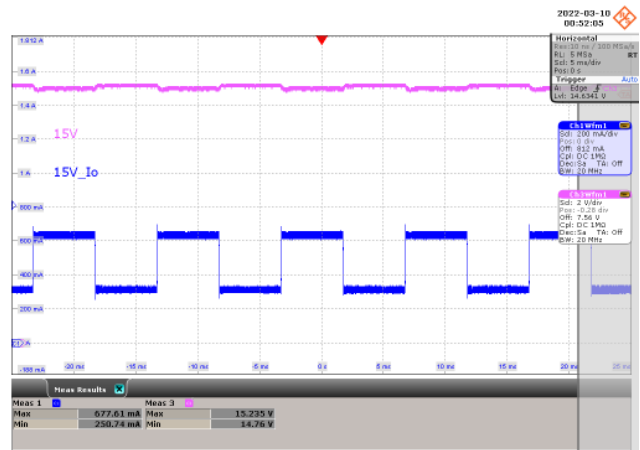

Figure 36 – 400 VDC Input.
 CH1: I_{OUT} , 200 mA / div., 5 ms / div.
 CH3: V_{OUT} , 2 V / div., 5 ms / div.
 $V_{OUT(MAX)} = 15.235\text{ V}$, $V_{OUT(MIN)} = 14.76\text{ V}$.

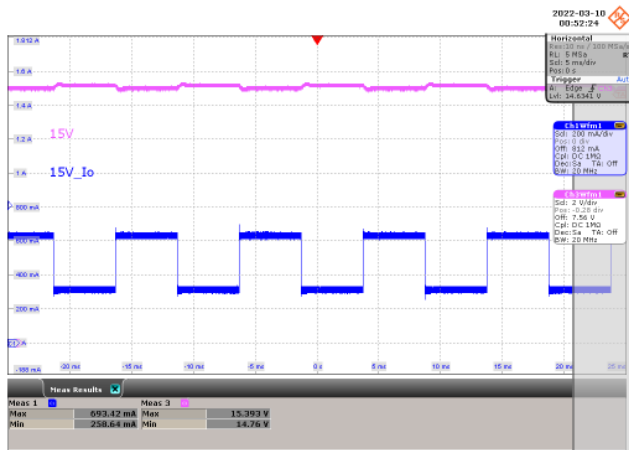

Figure 37 – 500 VDC Input.
 CH1: I_{OUT} , 200 mA / div., 5 ms / div.
 CH3: V_{OUT} , 2 V / div., 5 ms / div.
 $V_{OUT(MAX)} = 15.393\text{ V}$, $V_{OUT(MIN)} = 14.76\text{ V}$.

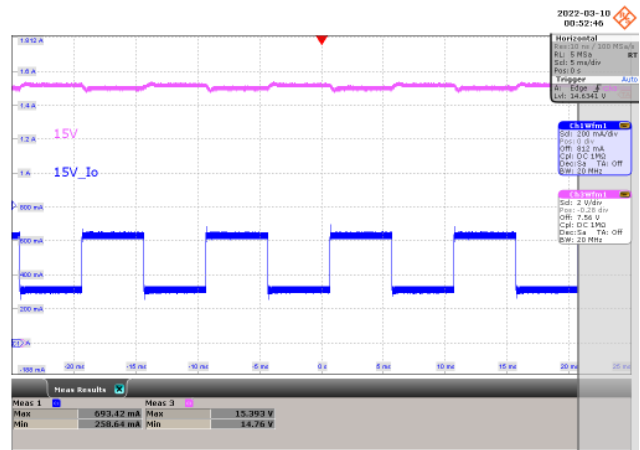

Figure 38 – 550 VDC Input.
 CH1: I_{OUT} , 200 mA / div., 5 ms / div.
 CH3: V_{OUT} , 2 V / div., 5 ms / div.
 $V_{OUT(MAX)} = 15.393\text{ V}$, $V_{OUT(MIN)} = 14.76\text{ V}$.

10.2 Switching Waveforms

10.2.1 Primary MOSFET Drain-Source Voltage and Current at Normal Operation

10.2.1.1 100% Load CC

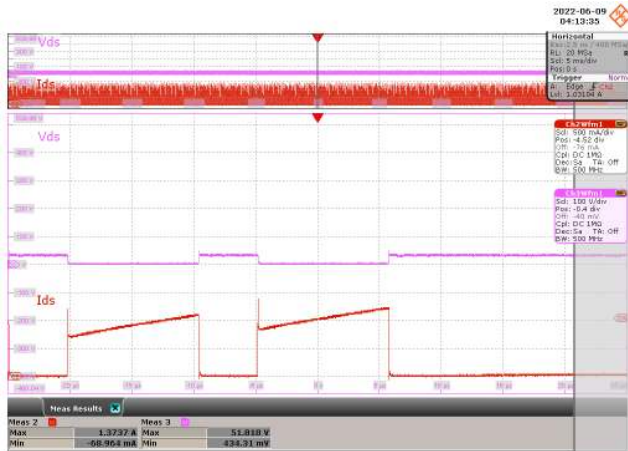

Figure 39 – 30 VDC Input.

CH2: I_{DS} , 500 mA / div., 5 ms / div.

CH3: V_{DS} , 100 V / div., 5 ms / div.

Zoom: 5 μ s / div.

$V_{DS(MAX)}$ = 51.818 V, $I_{DS(MAX)}$ = 1.3737 A.



Figure 40 – 60 VDC Input.

CH2: I_{DS} , 500 mA / div., 5 ms / div.

CH3: V_{DS} , 100 V / div., 5 ms / div.

Zoom: 5 μ s / div.

$V_{DS(MAX)}$ = 67.628 V, $I_{DS(MAX)}$ = 1.3342 A.

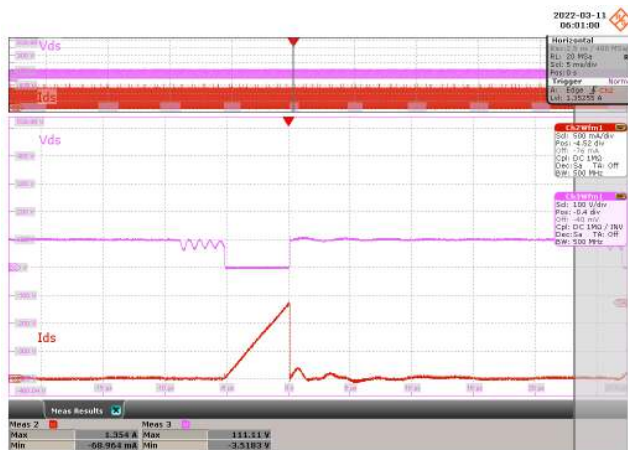

Figure 41 – 100 VDC Input.

CH2: I_{DS} , 500 mA / div., 5 ms / div.

CH3: V_{DS} , 100 V / div., 5 ms / div.

Zoom: 5 μ s / div.

$V_{DS(MAX)}$ = 111.11 V, $I_{DS(MAX)}$ = 1.354 A.



Figure 42 – 200 VDC Input.

CH2: I_{DS} , 500 mA / div., 5 ms / div.

CH3: V_{DS} , 100 V / div., 5 ms / div.

Zoom: 5 μ s / div.

$V_{DS(MAX)}$ = 213.87 V, $I_{DS(MAX)}$ = 1.4528 A.



Figure 43 – 300 VDC Input.
 CH2: I_{DS} , 500 mA / div., 5 ms / div.
 CH3: V_{DS} , 150 V / div., 5 ms / div.
 Zoom: 5 μ s / div.
 $V_{DS(MAX)}$ = 314.9 V, $I_{DS(MAX)}$ = 1.5318 A.

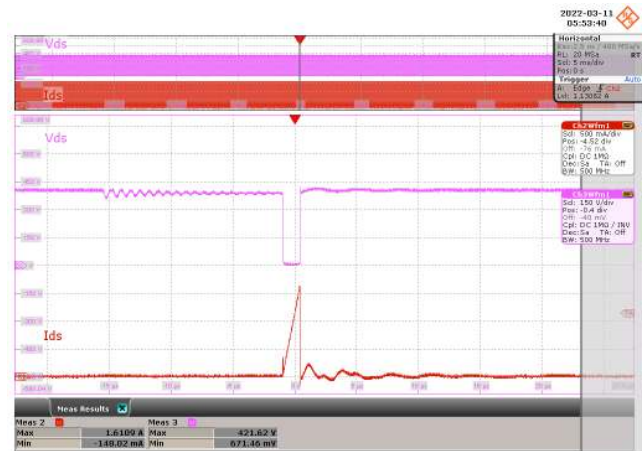

Figure 44 – 400 VDC Input.
 CH2: I_{DS} , 500 mA / div., 5 ms / div.
 CH3: V_{DS} , 150 V / div., 5 ms / div.
 Zoom: 5 μ s / div.
 $V_{DS(MAX)}$ = 421.62 V, $I_{DS(MAX)}$ = 1.6109 A.



Figure 45 – 500 VDC Input.
 CH2: I_{DS} , 500 mA / div., 5 ms / div.
 CH3: V_{DS} , 150 V / div., 5 ms / div.
 Zoom: 5 μ s / div.
 $V_{DS(MAX)}$ = 516.48 V, $I_{DS(MAX)}$ = 1.7097 A.

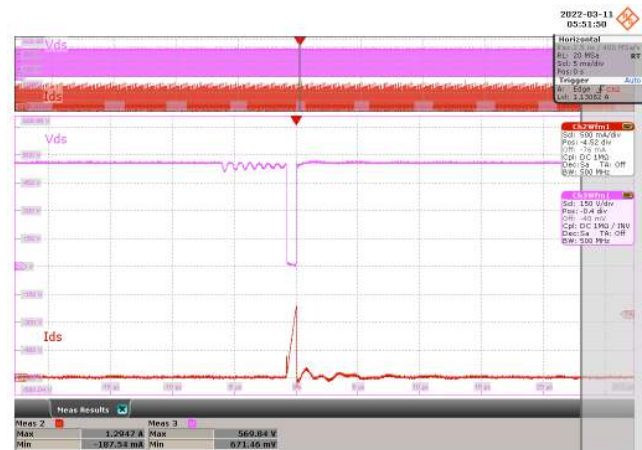

Figure 46 – 550 VDC Input.
 CH2: I_{DS} , 500 mA / div., 5 ms / div.
 CH3: V_{DS} , 150 V / div., 5 ms / div.
 Zoom: 5 μ s / div.
 $V_{DS(MAX)}$ = 569.84 V, $I_{DS(MAX)}$ = 1.2947 A.

10.2.1.2 10% Load CC

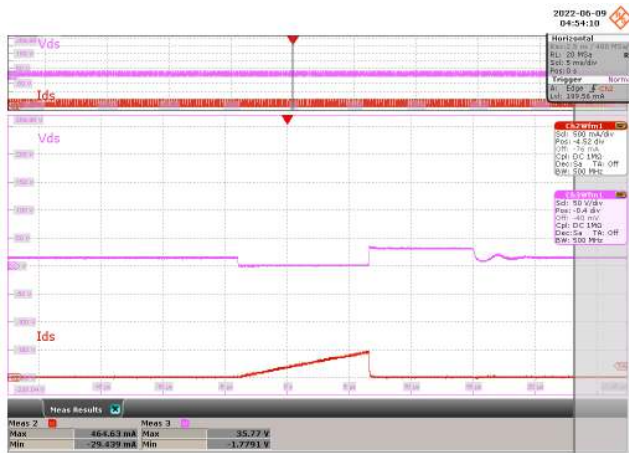

Figure 47 – 30 VDC Input.
 CH2: I_{DS} , 500 mA / div., 5 ms / div.
 CH3: V_{DS} , 50 V / div., 5 ms / div.
 Zoom: 5 μ s / div.
 $V_{DS(MAX)}$ = 35.77 V, $I_{DS(MAX)}$ = 0.46463 A.

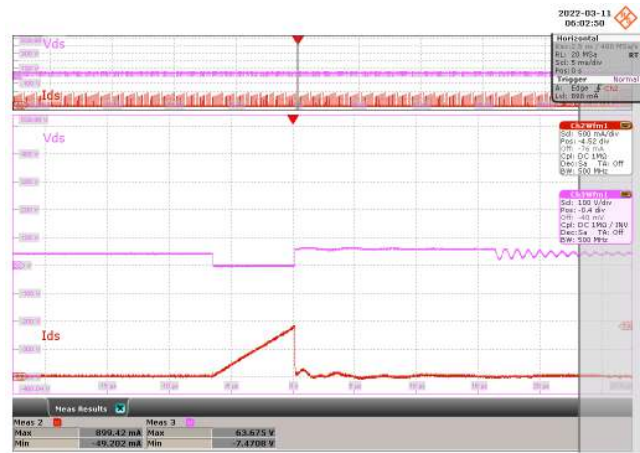

Figure 48 – 60 VDC Input.
 CH2: I_{DS} , 500 mA / div., 5 ms / div.
 CH3: V_{DS} , 100 V / div., 5 ms / div.
 Zoom: 5 μ s / div.
 $V_{DS(MAX)}$ = 63.675 V, $I_{DS(MAX)}$ = 0.89942 A.

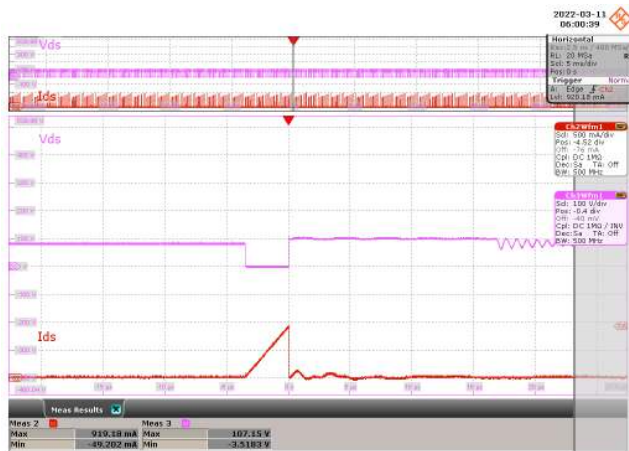

Figure 49 – 100 VDC Input.
 CH2: I_{DS} , 500 mA / div., 5 ms / div.
 CH3: V_{DS} , 100 V / div., 5 ms / div.
 Zoom: 5 μ s / div.
 $V_{DS(MAX)}$ = 107.15 V, $I_{DS(MAX)}$ = 0.91918 A.



Figure 50 – 200 VDC Input.
 CH2: I_{DS} , 500 mA / div., 5 ms / div.
 CH3: V_{DS} , 100 V / div., 5 ms / div.
 Zoom: 5 μ s / div.
 $V_{DS(MAX)}$ = 209.92 V, $I_{DS(MAX)}$ = 1.018 A.

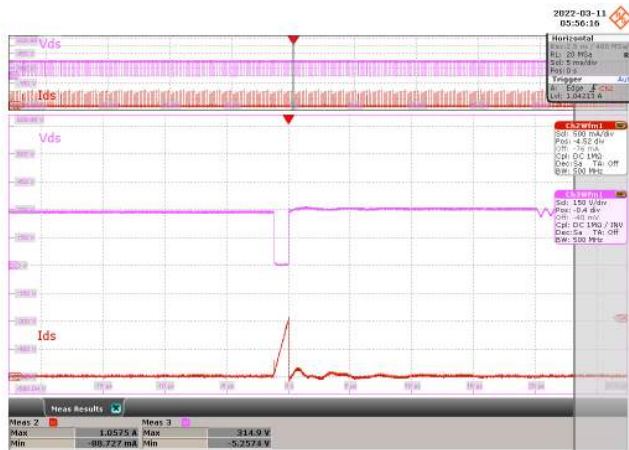

Figure 51 – 300 VDC Input.
 CH2: I_{DS} , 500 mA / div., 5 ms / div.
 CH3: V_{DS} , 150 V / div., 5 ms / div.
 Zoom: 5 μ s / div.
 $V_{DS(MAX)} = 314.9$ V, $I_{DS(MAX)} = 1.0575$ A.



Figure 52 – 400 VDC Input.
 CH2: I_{DS} , 500 mA / div., 5 ms / div.
 CH3: V_{DS} , 150 V / div., 5 ms / div.
 Zoom: 5 μ s / div.
 $V_{DS(MAX)} = 415.69$ V, $I_{DS(MAX)} = 1.1761$ A.



Figure 53 – 500 VDC Input.
 CH2: I_{DS} , 500 mA / div., 5 ms / div.
 CH3: V_{DS} , 150 V / div., 5 ms / div.
 Zoom: 5 μ s / div.
 $V_{DS(MAX)} = 516.48$ V, $I_{DS(MAX)} = 1.1761$ A.



Figure 54 – 550 VDC Input.
 CH2: I_{DS} , 500 mA / div., 5 ms / div.
 CH3: V_{DS} , 150 V / div., 5 ms / div.
 Zoom: 5 μ s / div.
 $V_{DS(MAX)} = 563.91$ V, $I_{DS(MAX)} = 1.2749$ A.

10.2.2 Primary MOSFET Drain-Source Voltage and Current at Start-up Operation

10.2.2.1 100% Load CC

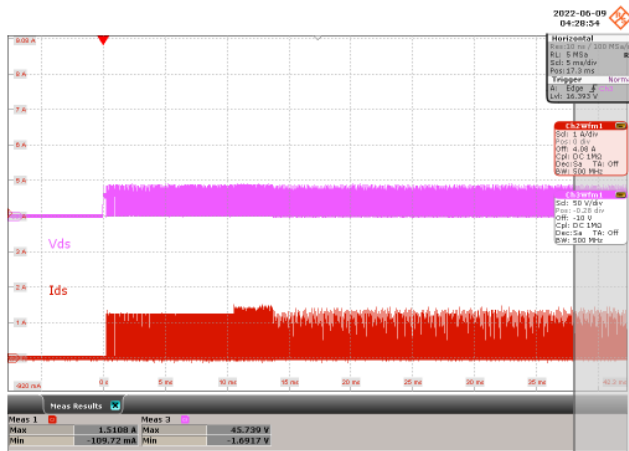

Figure 55 – 30 VDC Input.
 CH2: I_{DS} , 1 A / div., 5 ms / div.
 CH3: V_{DS} , 50 V / div., 5 ms / div.
 $V_{DS(MAX)} = 45.739$ V, $I_{DS(MAX)} = 1.5108$ A.

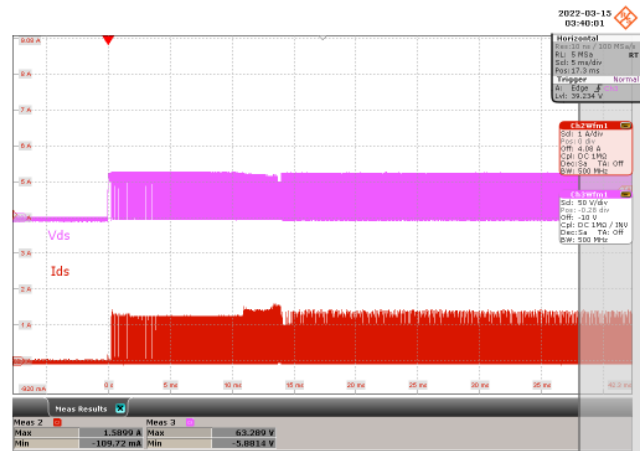

Figure 56 – 60 VDC Input.
 CH2: I_{DS} , 1 A / div., 5 ms / div.
 CH3: V_{DS} , 50 V / div., 5 ms / div.
 $V_{DS(MAX)} = 63.289$ V, $I_{DS(MAX)} = 1.5899$ A.

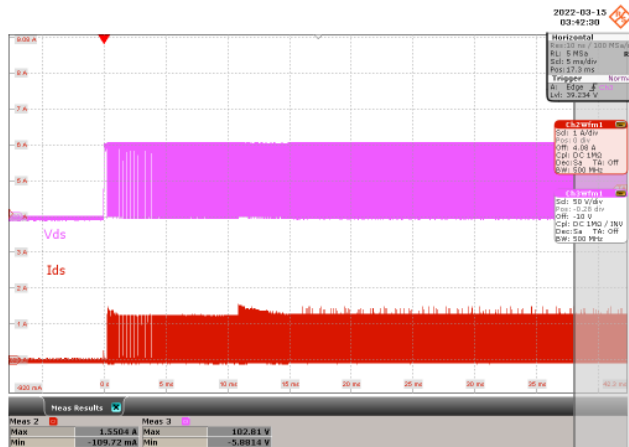

Figure 57 – 100 VDC Input.
 CH2: I_{DS} , 1 A / div., 5 ms / div.
 CH3: V_{DS} , 50 V / div., 5 ms / div.
 $V_{DS(MAX)} = 102.81$ V, $I_{DS(MAX)} = 1.5504$ A.

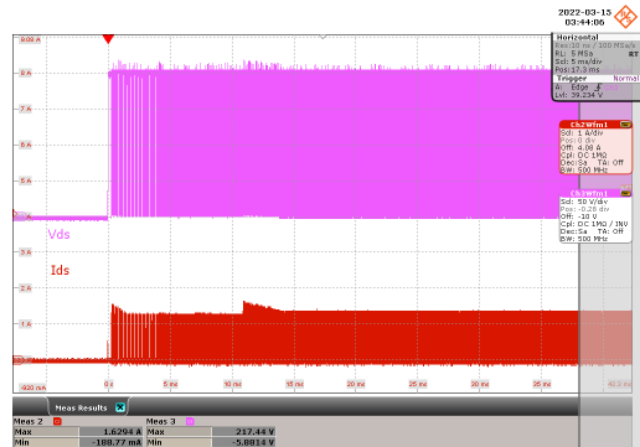

Figure 58 – 200 VDC Input.
 CH2: I_{DS} , 1 A / div., 5 ms / div.
 CH3: V_{DS} , 50 V / div., 5 ms / div.
 $V_{DS(MAX)} = 217.44$ V, $I_{DS(MAX)} = 1.6294$ A.

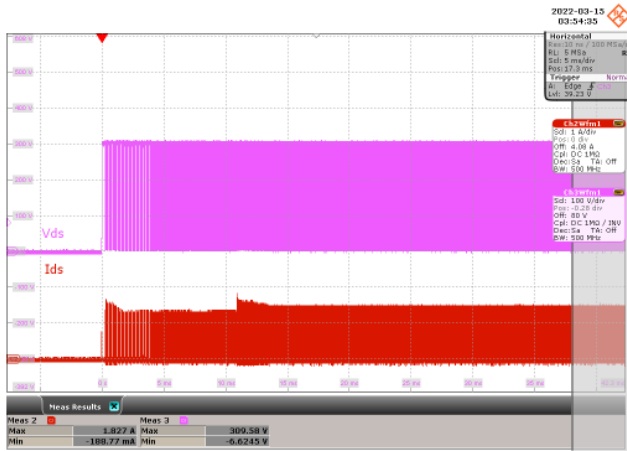

Figure 59 – 300 VDC Input.
 CH2: I_{DS} , 1 A / div., 5 ms / div.
 CH3: V_{DS} , 100 V / div., 5 ms / div.
 $V_{DS(MAX)} = 309.58\text{ V}$, $I_{DS(MAX)} = 1.827\text{ A}$.

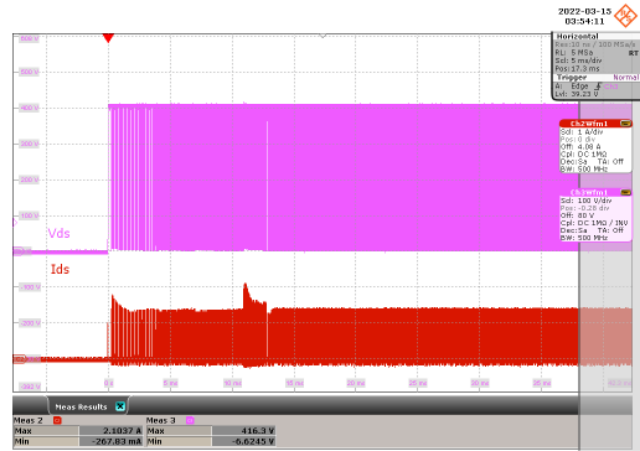

Figure 60 – 400 VDC Input.
 CH2: I_{DS} , 1 A / div., 5 ms / div.
 CH3: V_{DS} , 100 V / div., 5 ms / div.
 $V_{DS(MAX)} = 416.3\text{ V}$, $I_{DS(MAX)} = 2.1037\text{ A}$.

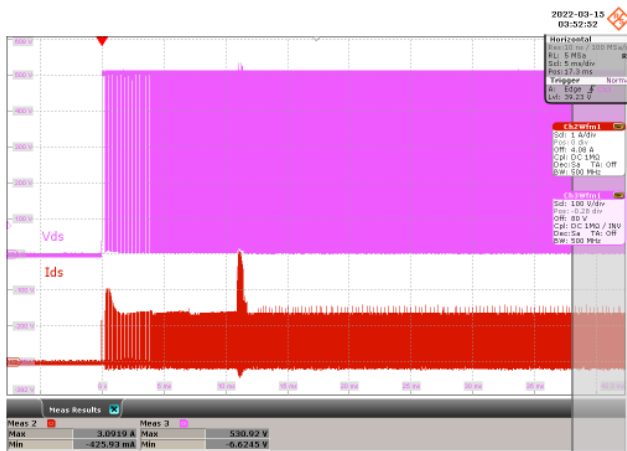

Figure 61 – 500 VDC Input.
 CH2: I_{DS} , 1 A / div., 5 ms / div.
 CH3: V_{DS} , 100 V / div., 5 ms / div.
 $V_{DS(MAX)} = 530.92\text{ V}$, $I_{DS(MAX)} = 3.0919\text{ A}$.

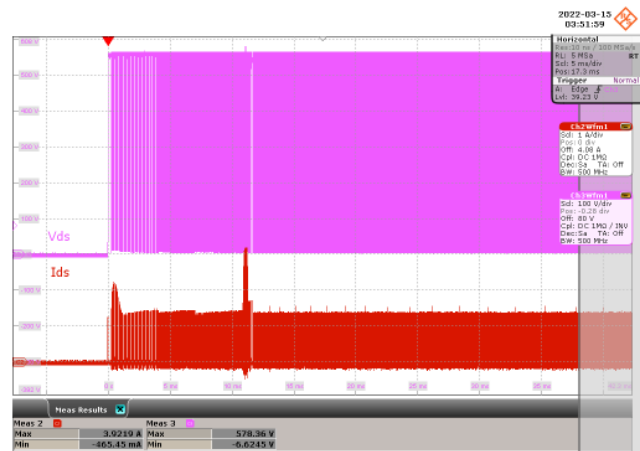

Figure 62 – 550 VDC Input.
 CH2: I_{DS} , 1 A / div., 5 ms / div.
 CH3: V_{DS} , 100 V / div., 5 ms / div.
 $V_{DS(MAX)} = 578.36\text{ V}$, $I_{DS(MAX)} = 3.9219\text{ A}$.

10.2.2.2 10% Load CC

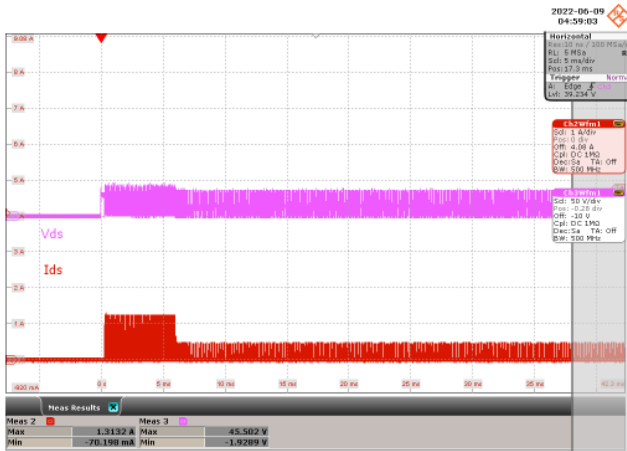

Figure 63 – 30 VDC Input.
 CH2: I_{DS} , 1 A / div., 5 ms / div.
 CH3: V_{DS} , 50 V / div., 5 ms / div.
 $V_{DS(MAX)} = 45.502$ V, $I_{DS(MAX)} = 1.3132$ A.

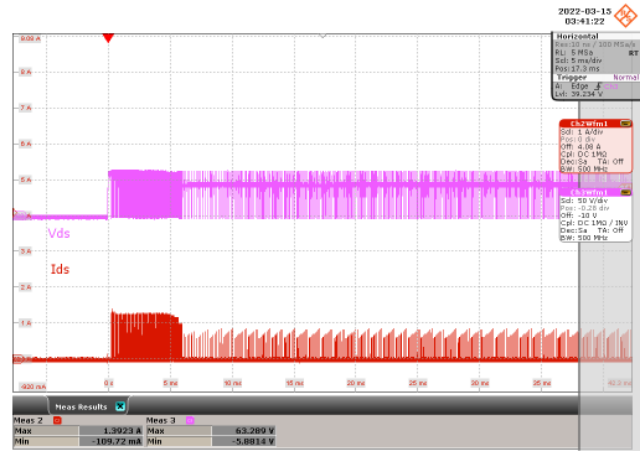

Figure 64 – 60 VDC Input.
 CH2: I_{DS} , 1 A / div., 5 ms / div.
 CH3: V_{DS} , 50 V / div., 5 ms / div.
 $V_{DS(MAX)} = 63.289$ V, $I_{DS(MAX)} = 1.3923$ A.

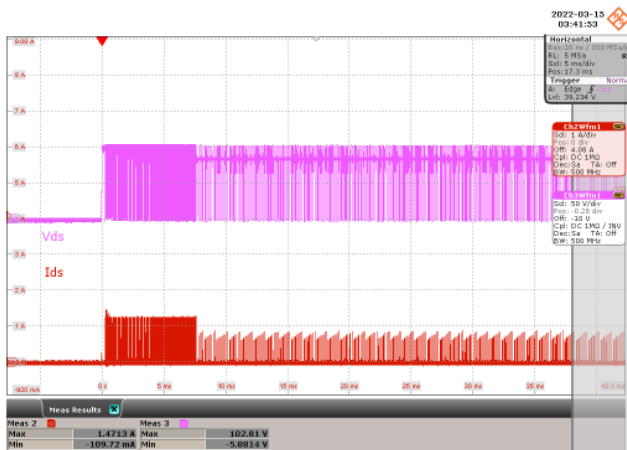

Figure 65 – 100 VDC Input.
 CH2: I_{DS} , 1 A / div., 5 ms / div.
 CH3: V_{DS} , 50 V / div., 5 ms / div.
 $V_{DS(MAX)} = 102.81$ V, $I_{DS(MAX)} = 1.4713$ A.

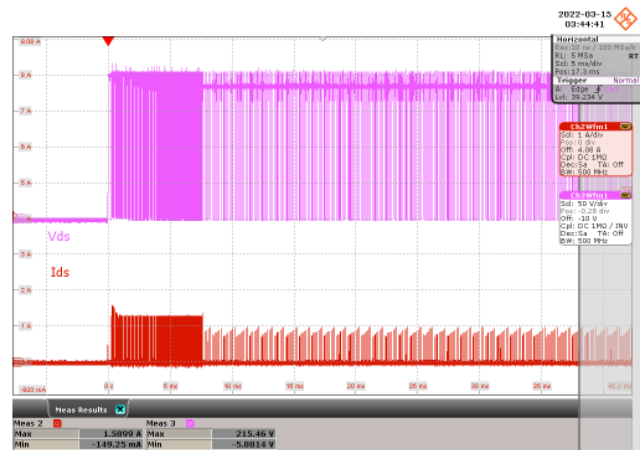

Figure 66 – 200 VDC Input.
 CH2: I_{DS} , 1 A / div., 5 ms / div.
 CH3: V_{DS} , 50 V / div., 5 ms / div.
 $V_{DS(MAX)} = 215.46$ V, $I_{DS(MAX)} = 1.5899$ A.

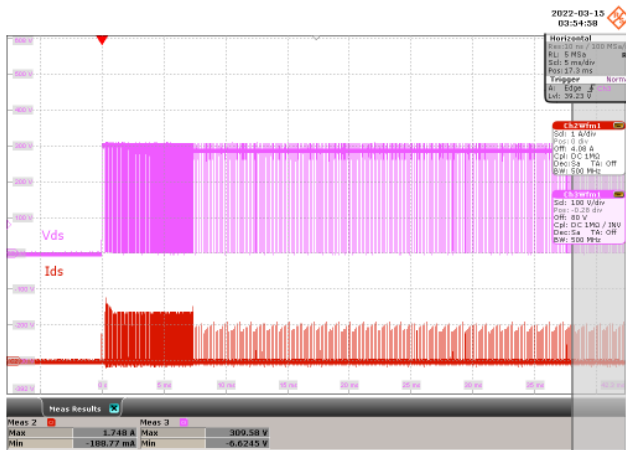

Figure 67 – 300 VDC Input.
 CH2: I_{DS} , 1 A / div., 5 ms / div.
 CH3: V_{DS} , 100 V / div., 5 ms / div.
 $V_{DS(MAX)} = 309.58\text{ V}$, $I_{DS(MAX)} = 1.748\text{ A}$.

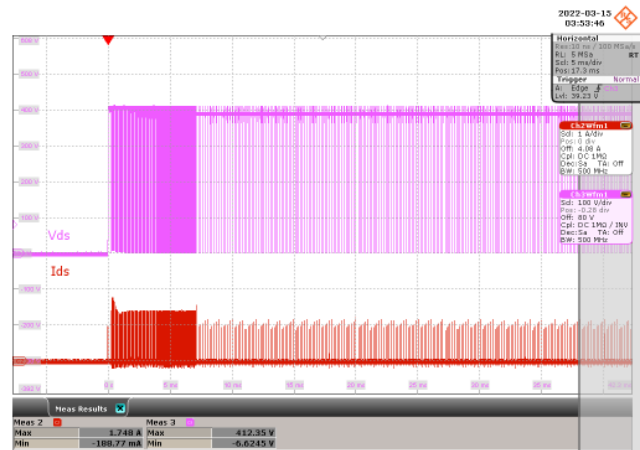

Figure 68 – 400 VDC Input.
 CH2: I_{DS} , 1 A / div., 5 ms / div.
 CH3: V_{DS} , 100 V / div., 5 ms / div.
 $V_{DS(MAX)} = 412.35\text{ V}$, $I_{DS(MAX)} = 1.748\text{ A}$.

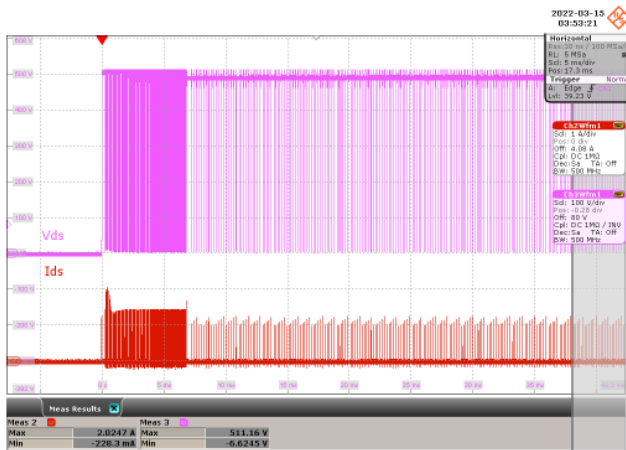

Figure 69 – 500 VDC Input.
 CH2: I_{DS} , 1 A / div., 5 ms / div.
 CH3: V_{DS} , 100 V / div., 5 ms / div.
 $V_{DS(MAX)} = 511.16\text{ V}$, $I_{DS(MAX)} = 2.0247\text{ A}$.

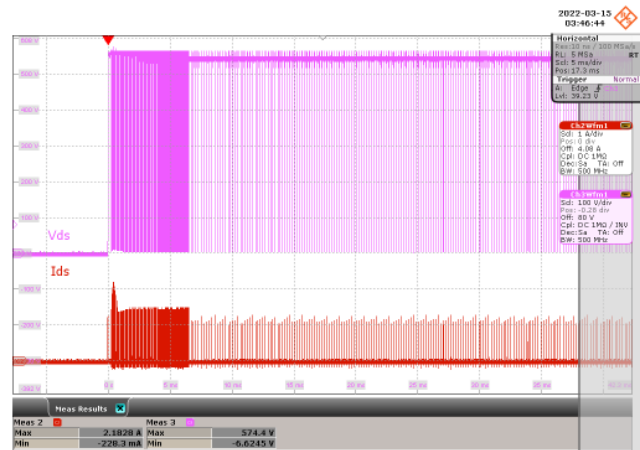

Figure 70 – 550 VDC Input.
 CH2: I_{DS} , 1 A / div., 5 ms / div.
 CH3: V_{DS} , 100 V / div., 5 ms / div.
 $V_{DS(MAX)} = 574.4\text{ V}$, $I_{DS(MAX)} = 2.1828\text{ A}$.

10.2.3 Free Wheeling Diode Voltage at Normal Operation

10.2.3.1 100% Load CC

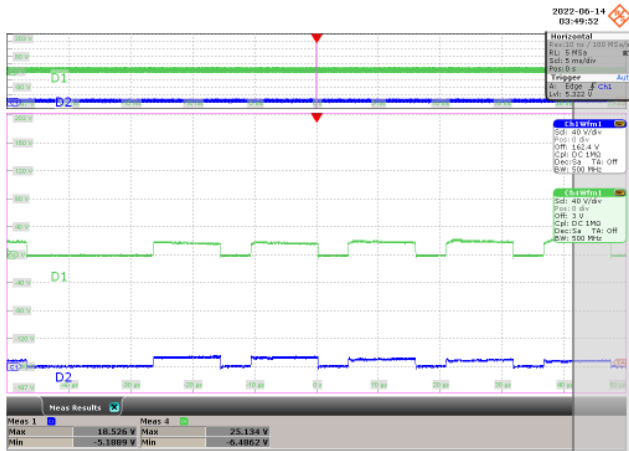

Figure 71 – 30 VDC Input.
 CH1: $V_{R,DIODE2}$, 40 V / div., 5 ms / div.
 CH4: $V_{R,DIODE1}$, 40 V / div., 5 ms / div.
 $PIV_{D1} = 25.134$ V, $PIV_{D2} = 18.526$ V.

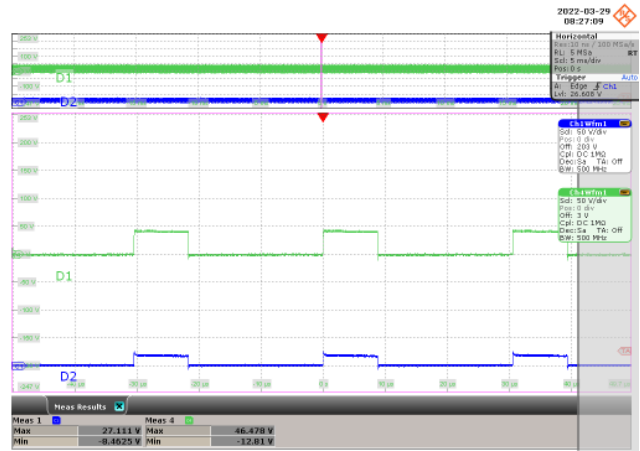

Figure 72 – 60 VDC Input.
 CH1: $V_{R,DIODE2}$, 50 V / div., 5 ms / div.
 CH4: $V_{R,DIODE1}$, 50 V / div., 5 ms / div.
 $PIV_{D1} = 46.478$ V, $PIV_{D2} = 27.111$ V.

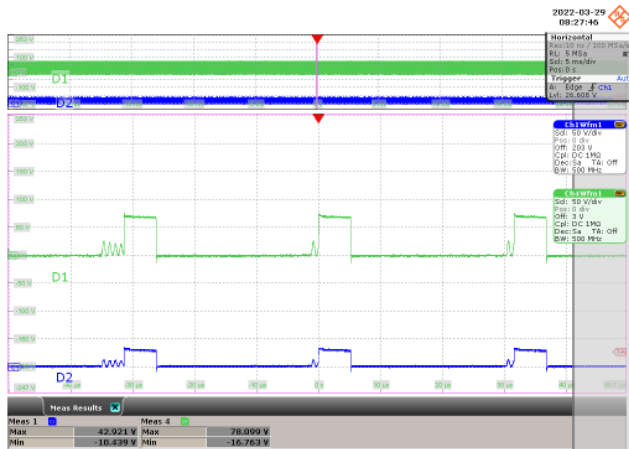

Figure 73 – 100 VDC Input.
 CH1: $V_{R,DIODE2}$, 50 V / div., 5 ms / div.
 CH4: $V_{R,DIODE1}$, 50 V / div., 5 ms / div.
 $PIV_{D1} = 78.099$ V, $PIV_{D2} = 42.921$ V.

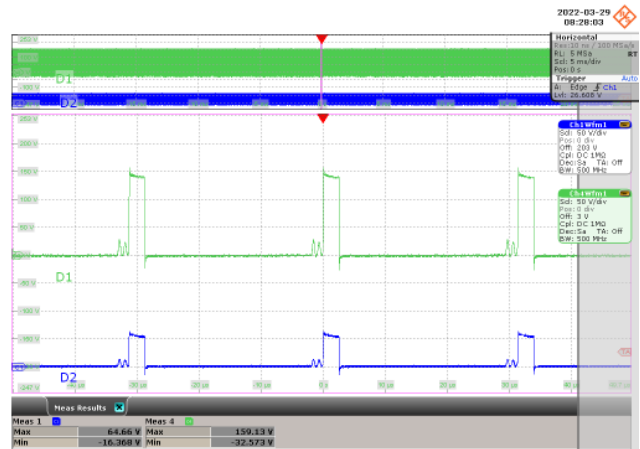

Figure 74 – 200 VDC Input.
 CH1: $V_{R,DIODE2}$, 50 V / div., 5 ms / div.
 CH4: $V_{R,DIODE1}$, 50 V / div., 5 ms / div.
 $PIV_{D1} = 159.13$ V, $PIV_{D2} = 64.66$ V.

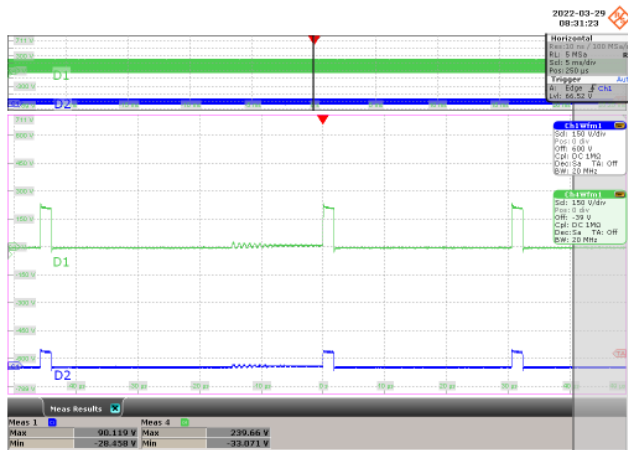

Figure 75 – 300 VDC Input.
 CH1: $V_{R,DIODE2}$, 150 V / div., 5 ms / div.
 CH4: $V_{R,DIODE1}$, 150 V / div., 5 ms / div.
 $PIV_{D1} = 239.66\text{ V}$, $PIV_{D2} = 90.119\text{ V}$.

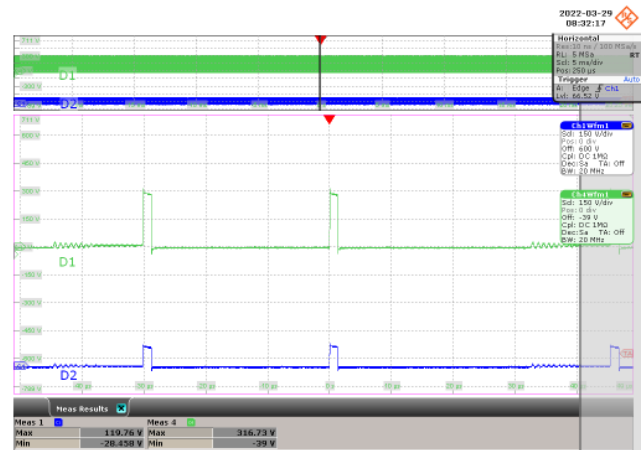

Figure 76 – 400 VDC Input.
 CH1: $V_{R,DIODE2}$, 150 V / div., 5 ms / div.
 CH4: $V_{R,DIODE1}$, 150 V / div., 5 ms / div.
 $PIV_{D1} = 316.73\text{ V}$, $PIV_{D2} = 119.76\text{ V}$.

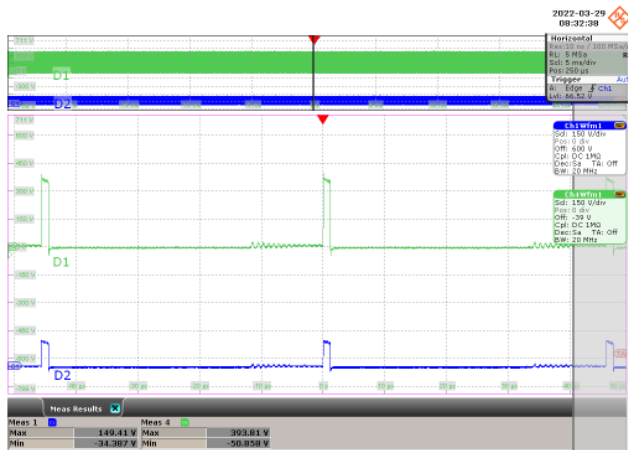

Figure 77 – 500 VDC Input.
 CH1: $V_{R,DIODE2}$, 150 V / div., 5 ms / div.
 CH4: $V_{R,DIODE1}$, 150 V / div., 5 ms / div.
 $PIV_{D1} = 393.81\text{ V}$, $PIV_{D2} = 149.41\text{ V}$.

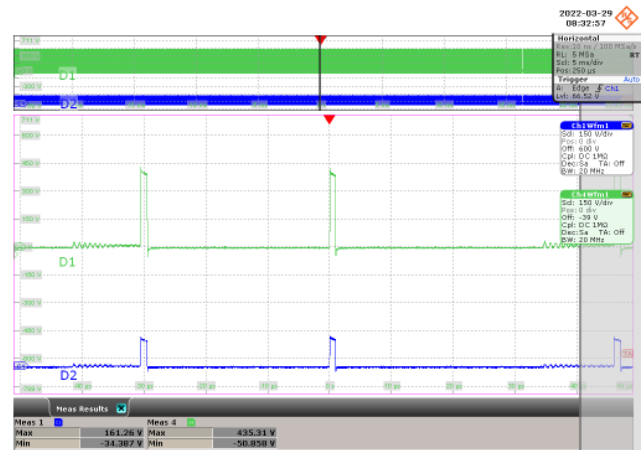

Figure 78 – 550 VDC Input.
 CH1: $V_{R,DIODE2}$, 150 V / div., 5 ms / div.
 CH4: $V_{R,DIODE1}$, 150 V / div., 5 ms / div.
 $PIV_{D1} = 435.31\text{ V}$, $PIV_{D2} = 161.26\text{ V}$.

10.2.3.2 10% Load CC

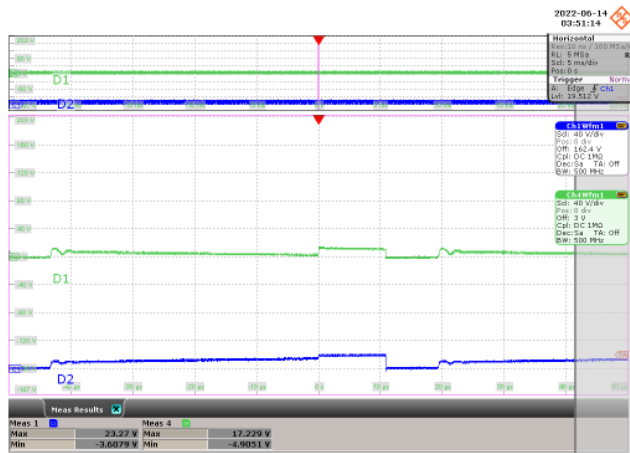

Figure 79 – 30 VDC Input.
 CH1: $V_{R,DIODE2}$, 40 V / div., 5 ms / div.
 CH4: $V_{R,DIODE1}$, 40 V / div., 5 ms / div.
 $PIV_{D1} = 17.229\text{ V}$, $PIV_{D2} = 23.27\text{ V}$.

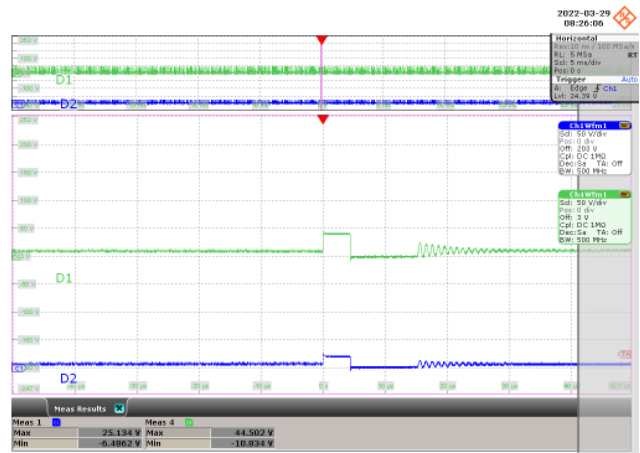

Figure 80 – 60 VDC Input.
 CH1: $V_{R,DIODE2}$, 50 V / div., 5 ms / div.
 CH4: $V_{R,DIODE1}$, 50 V / div., 5 ms / div.
 $PIV_{D1} = 44.502\text{ V}$, $PIV_{D2} = 25.134\text{ V}$.

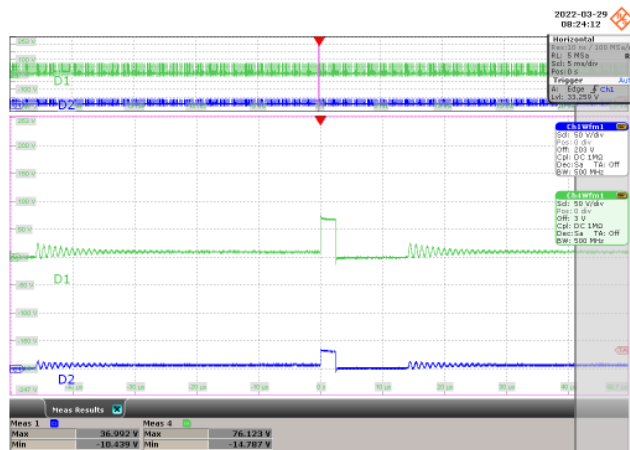

Figure 81 – 100 VDC Input.
 CH1: $V_{R,DIODE2}$, 50 V / div., 5 ms / div.
 CH4: $V_{R,DIODE1}$, 50 V / div., 5 ms / div.
 $PIV_{D1} = 76.123\text{ V}$, $PIV_{D2} = 36.992\text{ V}$.

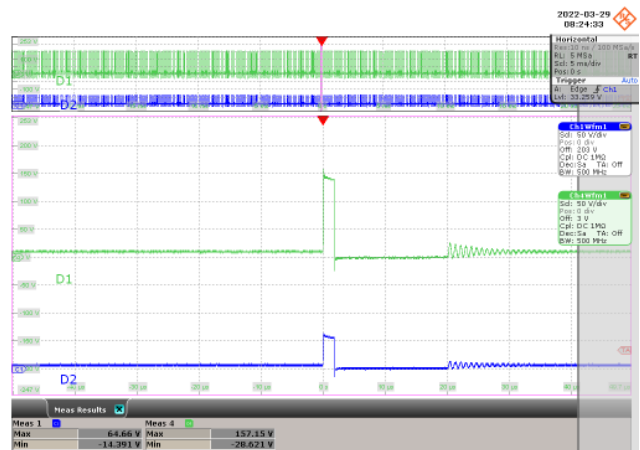

Figure 82 – 200 VDC Input.
 CH1: $V_{R,DIODE2}$, 50 V / div., 5 ms / div.
 CH4: $V_{R,DIODE1}$, 50 V / div., 5 ms / div.
 $PIV_{D1} = 157.15\text{ V}$, $PIV_{D2} = 64.66\text{ V}$.

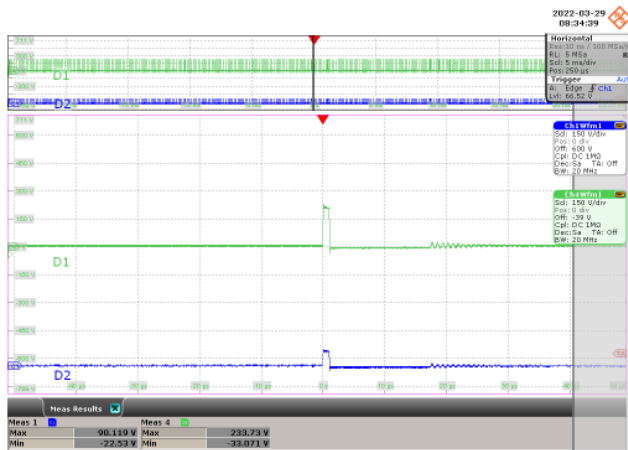

Figure 83 – 300 VDC Input.
 CH1: $V_{R,DIODE2}$, 150 V / div., 5 ms / div.
 CH4: $V_{R,DIODE1}$, 150 V / div., 5 ms / div.
 $PIV_{D1} = 223.73\text{ V}$, $PIV_{D2} = 90.119\text{ V}$.

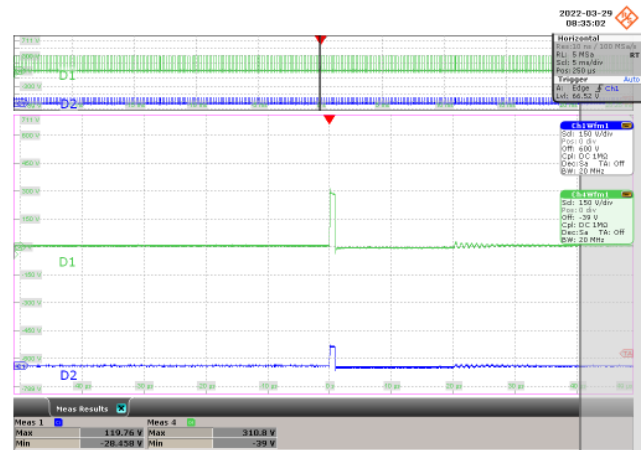

Figure 84 – 400 VDC Input.
 CH1: $V_{R,DIODE2}$, 150 V / div., 5 ms / div.
 CH4: $V_{R,DIODE1}$, 150 V / div., 5 ms / div.
 $PIV_{D1} = 310.8\text{ V}$, $PIV_{D2} = 119.76\text{ V}$.

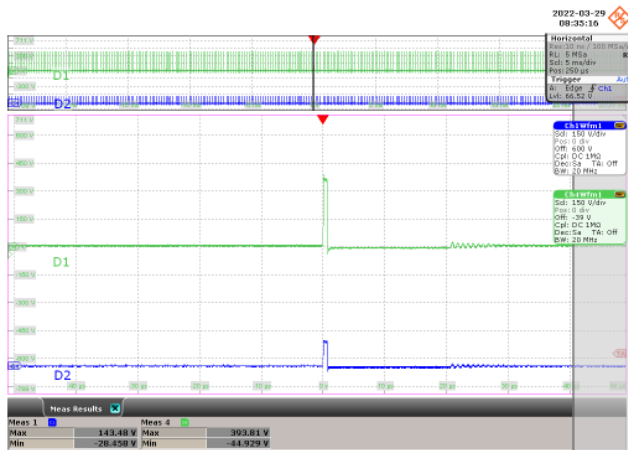

Figure 85 – 500 VDC Input.
 CH1: $V_{R,DIODE2}$, 150 V / div., 5 ms / div.
 CH4: $V_{R,DIODE1}$, 150 V / div., 5 ms / div.
 $PIV_{D1} = 393.81\text{ V}$, $PIV_{D2} = 143.48\text{ V}$.

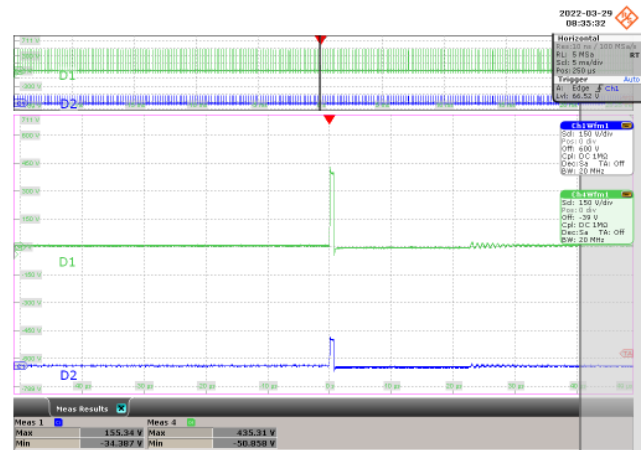

Figure 86 – 550 VDC Input.
 CH1: $V_{R,DIODE2}$, 150 V / div., 5 ms / div.
 CH4: $V_{R,DIODE1}$, 150 V / div., 5 ms / div.
 $PIV_{D1} = 435.31\text{ V}$, $PIV_{D2} = 155.34\text{ V}$.

10.2.4 Free Wheeling Diode Voltage at Start-up

10.2.4.1 100% Load CC

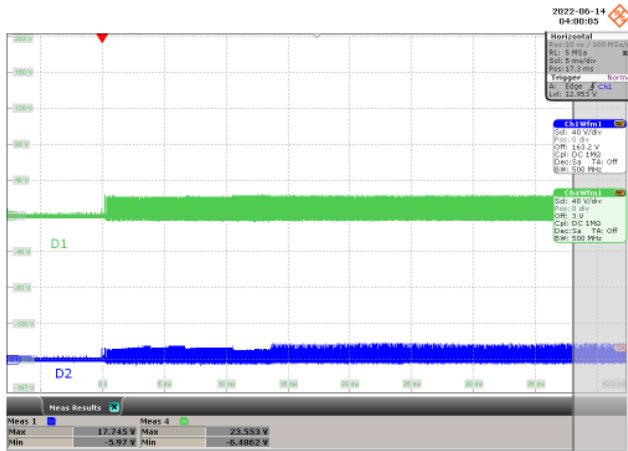

Figure 87 – 30 VDC Input.
 CH1: $V_{R,DIODE1}$, 40 V / div., 5 ms / div.
 CH4: $V_{R,DIODE2}$, 40 V / div., 5 ms / div.
 $PIV_{D1} = 23.553$ V, $PIV_{D2} = 17.745$ V.

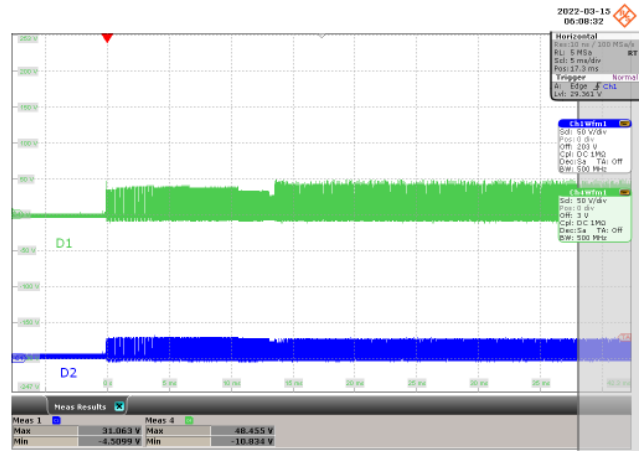

Figure 88 – 60 VDC Input.
 CH1: $V_{R,DIODE1}$, 50 V / div., 5 ms / div.
 CH4: $V_{R,DIODE2}$, 50 V / div., 5 ms / div.
 $PIV_{D1} = 48.455$ V, $PIV_{D2} = 31.063$ V.

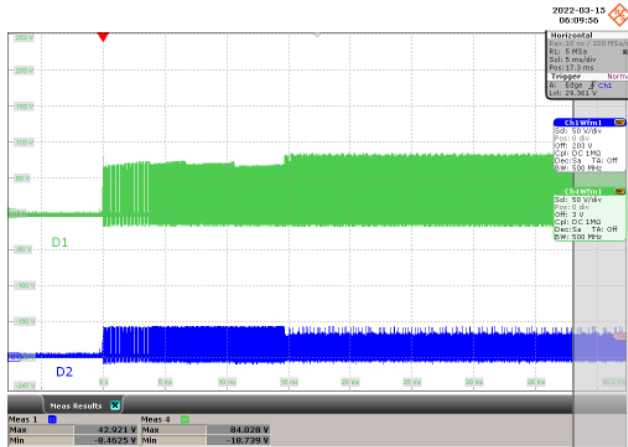

Figure 89 – 100 VDC Input.
 CH1: $V_{R,DIODE1}$, 50 V / div., 5 ms / div.
 CH4: $V_{R,DIODE2}$, 50 V / div., 5 ms / div.
 $PIV_{D1} = 84.028$ V, $PIV_{D2} = 42.921$ V.

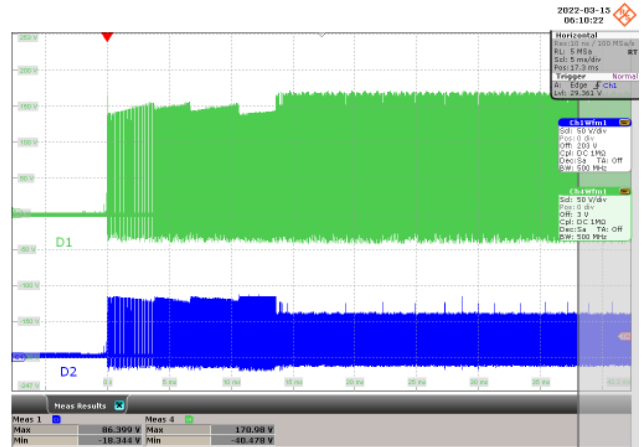

Figure 90 – 200 VDC Input.
 CH1: $V_{R,DIODE1}$, 50 V / div., 5 ms / div.
 CH4: $V_{R,DIODE2}$, 50 V / div., 5 ms / div.
 $PIV_{D1} = 170.98$ V, $PIV_{D2} = 86.399$ V.

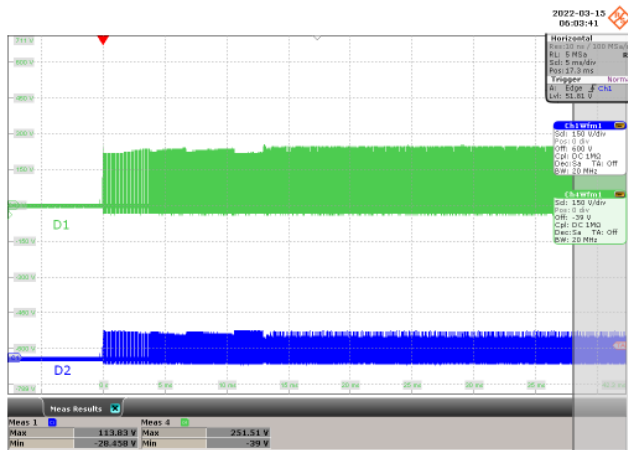

Figure 91 – 300 VDC Input.
 CH1: $V_{R,DIODE1}$, 150 V / div., 5 ms / div.
 CH4: $V_{R,DIODE2}$, 150 V / div., 5 ms / div.
 $PIV_{D1} = 251.51\text{ V}$, $PIV_{D2} = 113.83\text{ V}$.

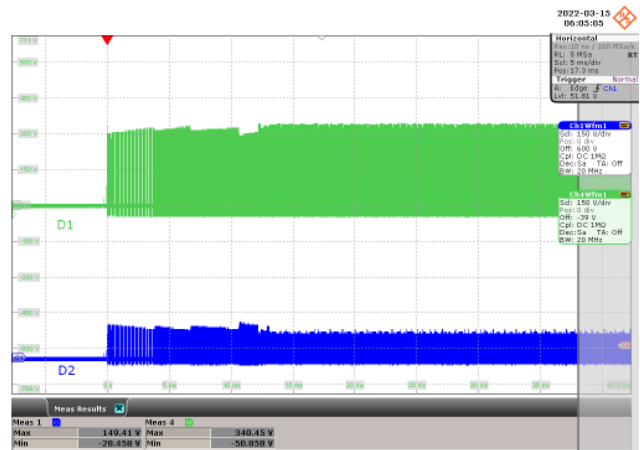

Figure 92 – 400 VDC Input.
 CH1: $V_{R,DIODE1}$, 150 V / div., 5 ms / div.
 CH4: $V_{R,DIODE2}$, 150 V / div., 5 ms / div.
 $PIV_{D1} = 340.45\text{ V}$, $PIV_{D2} = 149.41\text{ V}$.

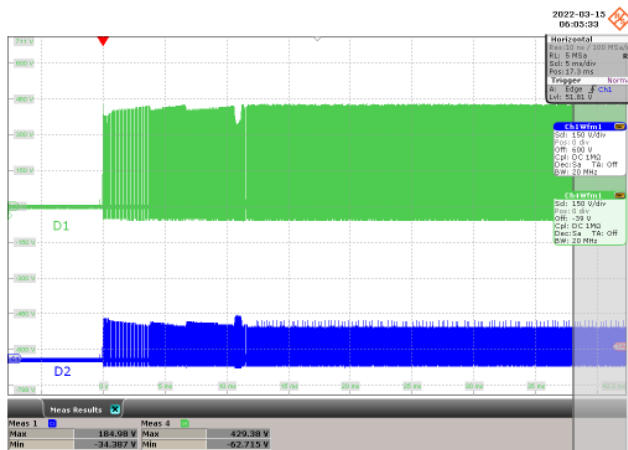

Figure 93 – 500 VDC Input.
 CH1: $V_{R,DIODE1}$, 150 V / div., 5 ms / div.
 CH4: $V_{R,DIODE2}$, 150 V / div., 5 ms / div.
 $PIV_{D1} = 429.38\text{ V}$, $PIV_{D2} = 184.98\text{ V}$.

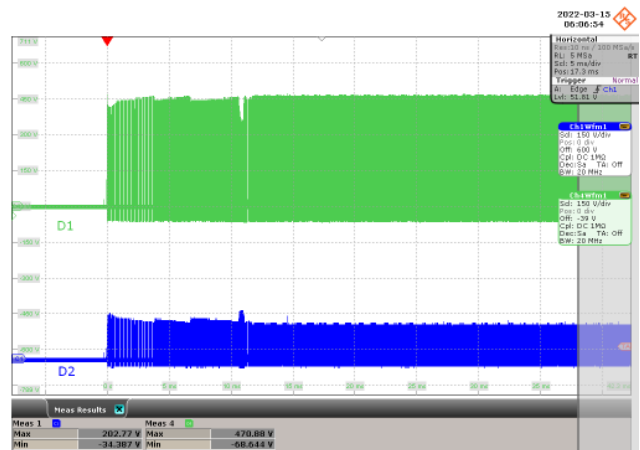

Figure 94 – 550 VDC Input.
 CH1: $V_{R,DIODE1}$, 150 V / div., 5 ms / div.
 CH4: $V_{R,DIODE2}$, 150 V / div., 5 ms / div.
 $PIV_{D1} = 470.88\text{ V}$, $PIV_{D2} = 202.77\text{ V}$.

10.2.4.2 10% Load CC

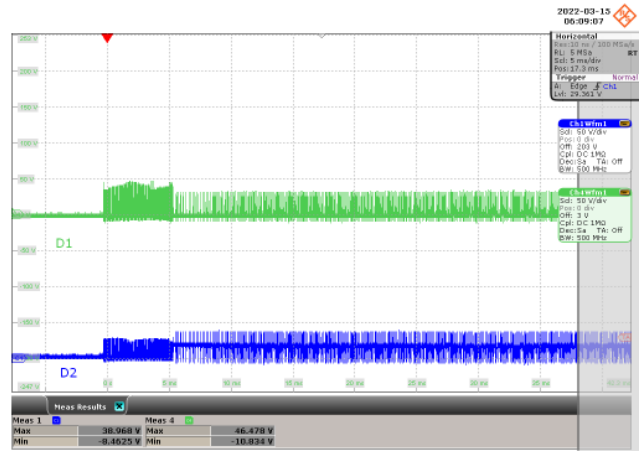
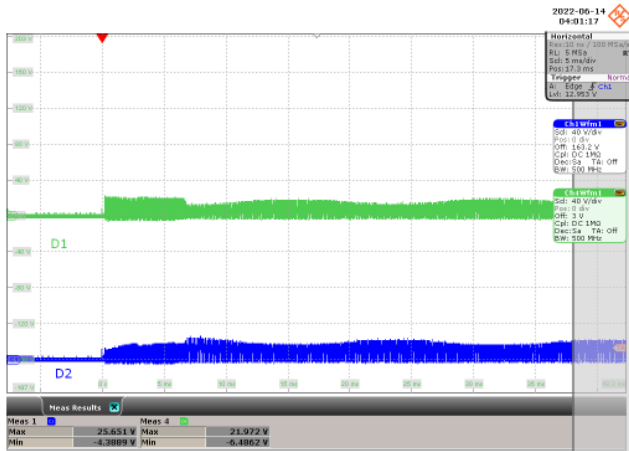

Figure 95 – 30 VDC Input.
 CH1: $V_{R,DIODE1}$, 40 V / div., 5 ms / div.
 CH4: $V_{R,DIODE2}$, 40 V / div., 5 ms / div.
 $PIV_{D1} = 21.972$ V, $PIV_{D2} = 25.651$ V.

Figure 96 – 60 VDC Input.
 CH1: $V_{R,DIODE1}$, 50 V / div., 5 ms / div.
 CH4: $V_{R,DIODE2}$, 50 V / div., 5 ms / div.
 $PIV_{D1} = 46.478$ V, $PIV_{D2} = 38.968$ V.

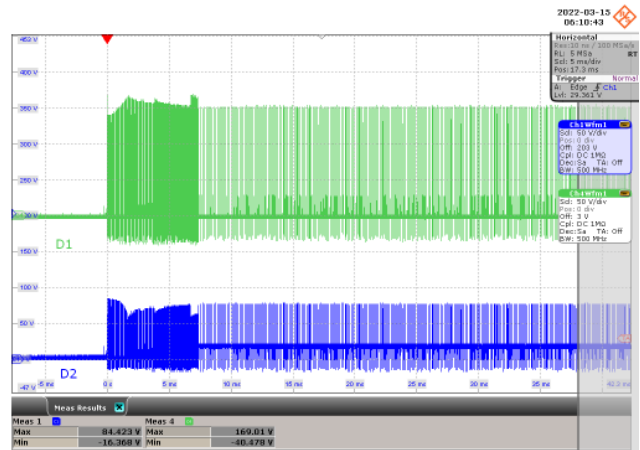
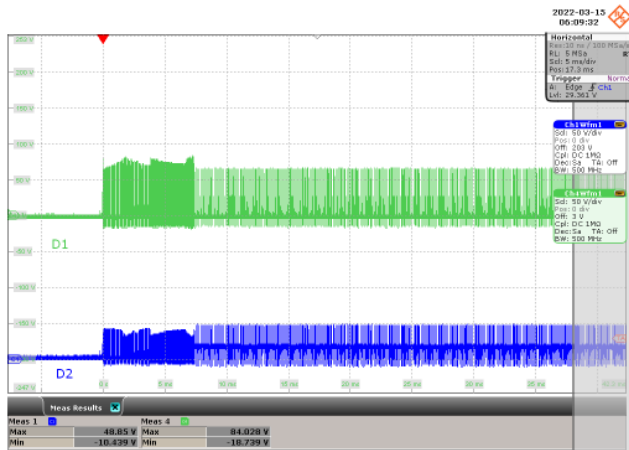

Figure 97 – 100 VDC Input.
 CH1: $V_{R,DIODE1}$, 50 V / div., 5 ms / div.
 CH4: $V_{R,DIODE2}$, 50 V / div., 5 ms / div.
 $PIV_{D1} = 84.028$ V, $PIV_{D2} = 48.85$ V.

Figure 98 – 200 VDC Input.
 CH1: $V_{R,DIODE1}$, 50 V / div., 5 ms / div.
 CH4: $V_{R,DIODE2}$, 50 V / div., 5 ms / div.
 $PIV_{D1} = 169.01$ V, $PIV_{D2} = 84.423$ V.

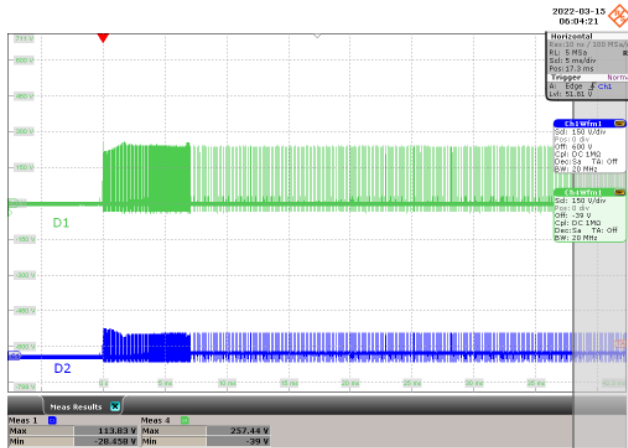

Figure 99 – 300 VDC Input.
 CH1: $V_{R,DIODE1}$, 150 V / div., 5 ms / div.
 CH4: $V_{R,DIODE2}$, 150 V / div., 5 ms / div.
 $PIV_{D1} = 257.44$ V, $PIV_{D2} = 113.83$ V.

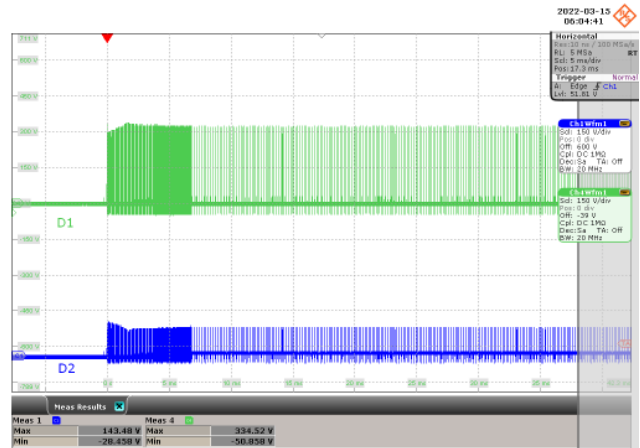

Figure 100 – 400 VDC Input.
 CH1: $V_{R,DIODE1}$, 150 V / div., 5 ms / div.
 CH4: $V_{R,DIODE2}$, 150 V / div., 5 ms / div.
 $PIV_{D1} = 334.52$ V, $PIV_{D2} = 143.48$ V.

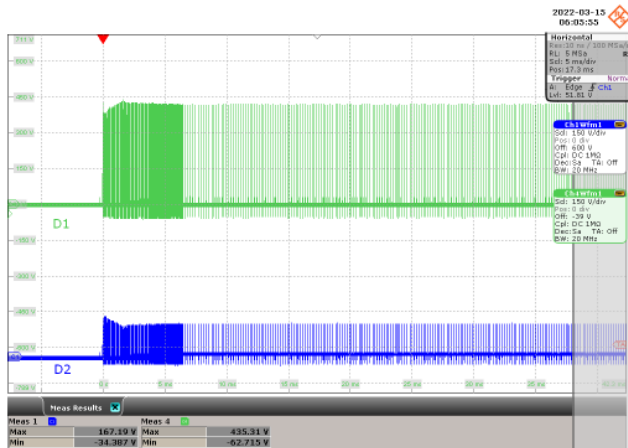

Figure 101 – 500 VDC Input.
 CH1: $V_{R,DIODE1}$, 150 V / div., 5 ms / div.
 CH4: $V_{R,DIODE2}$, 150 V / div., 5 ms / div.
 $PIV_{D1} = 435.31$ V, $PIV_{D2} = 167.19$ V.

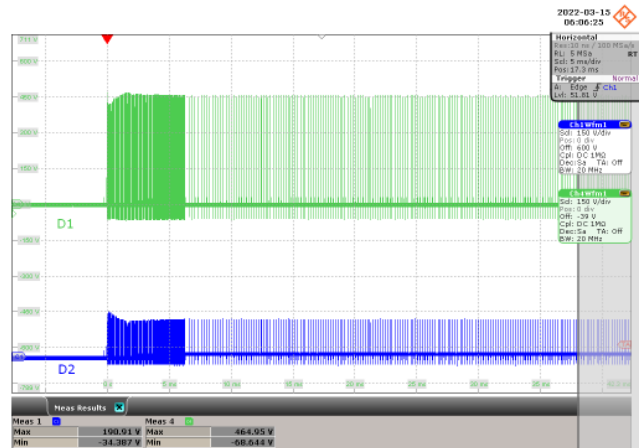

Figure 102 – 550 VDC Input.
 CH1: $V_{R,DIODE1}$, 150 V / div., 5 ms / div.
 CH4: $V_{R,DIODE2}$, 150 V / div., 5 ms / div.
 $PIV_{D1} = 464.95$ V, $PIV_{D2} = 190.91$ V.

10.3 Output Start-up

10.3.1 Output Start-up 85 °C Ambient

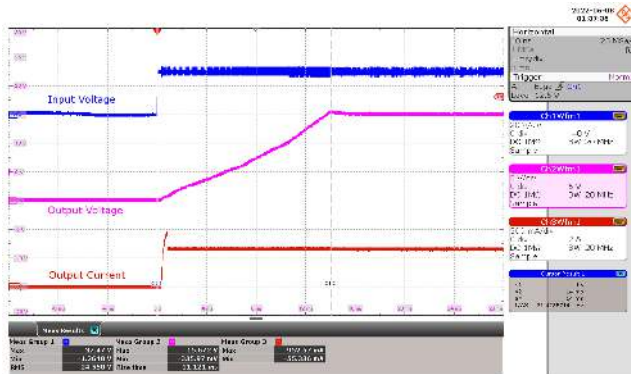

Figure 103 – 30 VDC Input. CC Full Load.
 CH1: V_{INPUT} , 20 V / div., 4 ms / div.
 CH3: V_{OUT} , 5 V / div., 4 ms / div.
 CH4: I_{OUT} , 500 mA / div., 4 ms / div.
 Rise Time V_{OUT} = 11.121 ms.

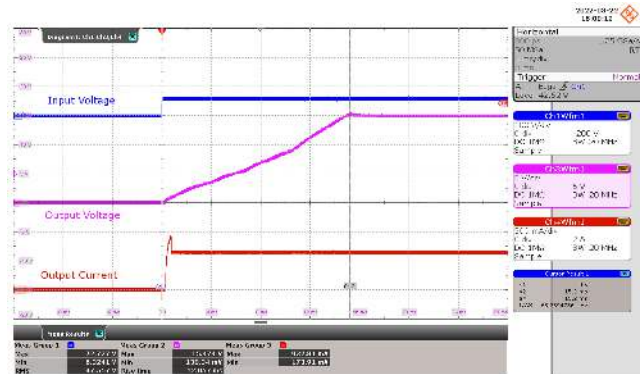

Figure 104 – 60 VDC Input. CC Full Load.
 CH1: V_{INPUT} , 100 V / div., 4 ms / div.
 CH3: V_{OUT} , 5 V / div., 4 ms / div.
 CH4: I_{OUT} , 500 mA / div., 4 ms / div.
 Rise Time V_{OUT} = 12.057 ms.

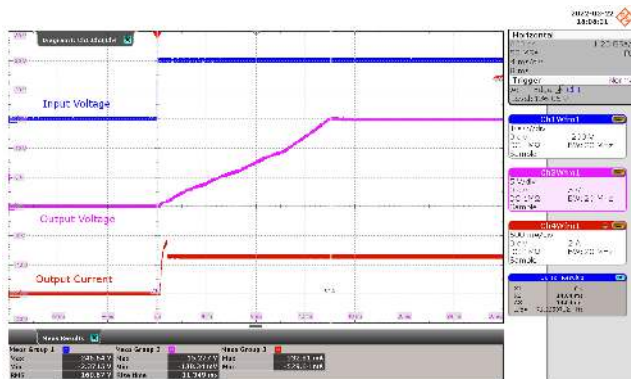

Figure 105 – 200 VDC Input. CC Full Load.
 CH1: V_{INPUT} , 100 V / div., 4 ms / div.
 CH3: V_{OUT} , 5 V / div., 4 ms / div.
 CH4: I_{OUT} , 500 mA / div., 4 ms / div.
 Rise Time V_{OUT} = 11.349 ms.

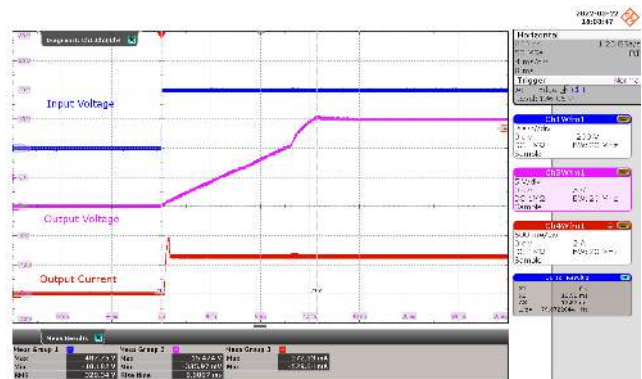

Figure 106 – 400 VDC Input. CC Full Load.
 CH1: V_{INPUT} , 200 V / div., 4 ms / div.
 CH3: V_{OUT} , 5 V / div., 4 ms / div.
 CH4: I_{OUT} , 500 mA / div., 4 ms / div.
 Rise Time V_{OUT} = 9.900 ms.

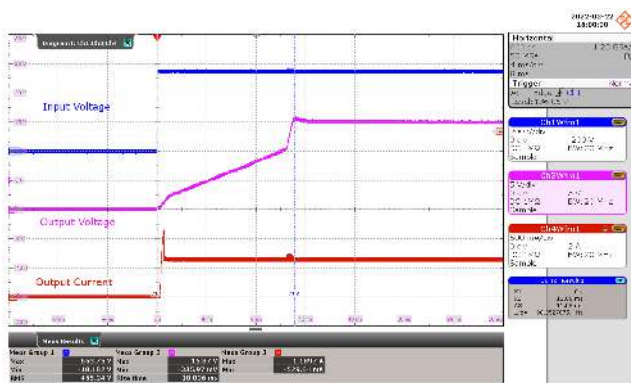

Figure 107 – 550 VDC Input. CC Full Load.
 CH1: V_{INPUT} , 200 V / div., 4 ms / div.
 CH3: V_{OUT} , 5 V / div., 4 ms / div.
 CH4: I_{OUT} , 500 mA / div., 4 ms / div.
 Rise Time V_{OUT} = 10.036 ms.

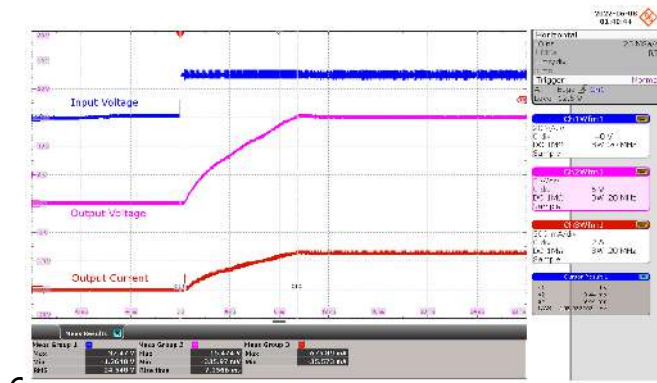

Figure 108 – 30 VDC Input. CR Full Load.
 CH1: V_{INPUT} , 20 V / div., 4 ms / div.
 CH3: V_{OUT} , 5 V / div., 4 ms / div.
 CH4: I_{OUT} , 500 mA / div., 4 ms / div.
 Rise Time V_{OUT} = 7.1566 ms.

6

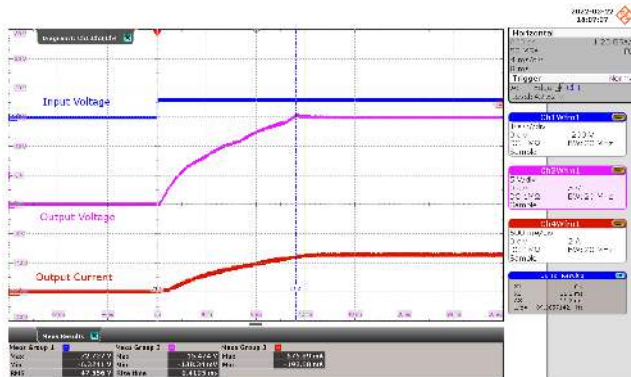

Figure 109 – 60 VDC Input. CR Full Load.
 CH1: V_{INPUT} , 100 V / div., 4 ms / div.
 CH3: V_{OUT} , 5 V / div., 4 ms / div.
 CH4: I_{OUT} , 500 mA / div., 4 ms / div.
 Rise Time V_{OUT} = 8.419 ms.

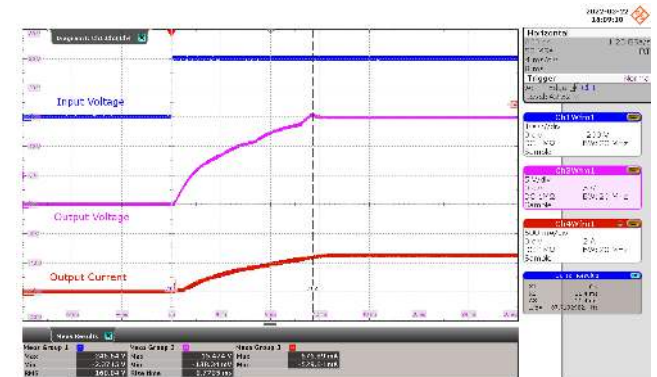

Figure 110 – 200 VDC Input. CR Full Load.
 CH1: V_{INPUT} , 100 V / div., 4 ms / div.
 CH3: V_{OUT} , 5 V / div., 4 ms / div.
 CH4: I_{OUT} , 500 mA / div., 4 ms / div.
 Rise Time V_{OUT} = 8.770 ms.



Figure 111 – 400 VDC Input. CR Full Load.
 CH1: V_{INPUT} , 200 V / div., 4 ms / div.
 CH3: V_{OUT} , 5 V / div., 4 ms / div.
 CH4: I_{OUT} , 500 mA / div., 4 ms / div.
 Rise Time V_{OUT} = 7.449 ms.

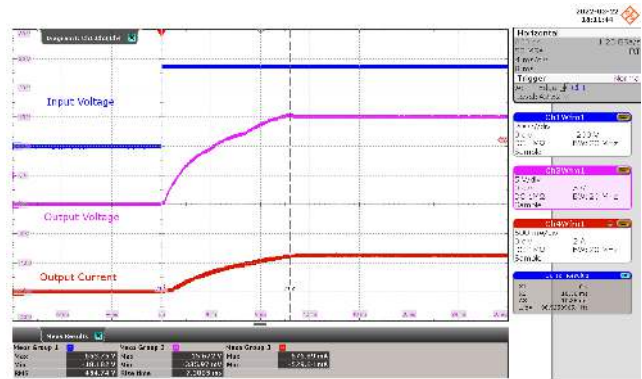

Figure 112 – 550 VDC Input. CR Full Load.
 CH1: V_{INPUT} , 200 V / div., 4 ms / div.
 CH3: V_{OUT} , 5 V / div., 4 ms / div.
 CH4: I_{OUT} , 500 mA / div., 4 ms / div.
 Rise Time V_{OUT} = 7.300 ms.

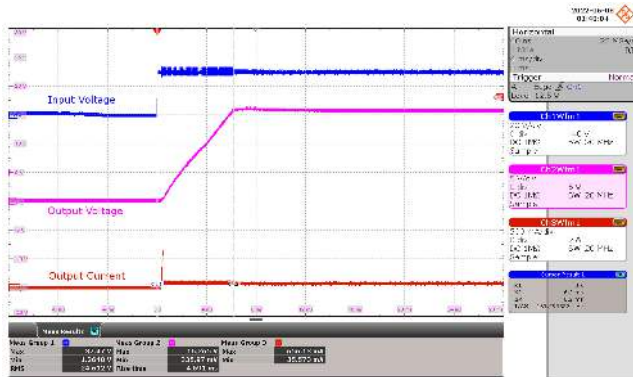

Figure 113 – 30 VDC Input. CC 10% Load.
 CH1: V_{INPUT} , 20 V / div., 4 ms / div.
 CH3: V_{OUT} , 5 V / div., 4 ms / div.
 CH4: I_{OUT} , 500 mA / div., 4 ms / div.
 Rise Time V_{OUT} = 4.691 ms.

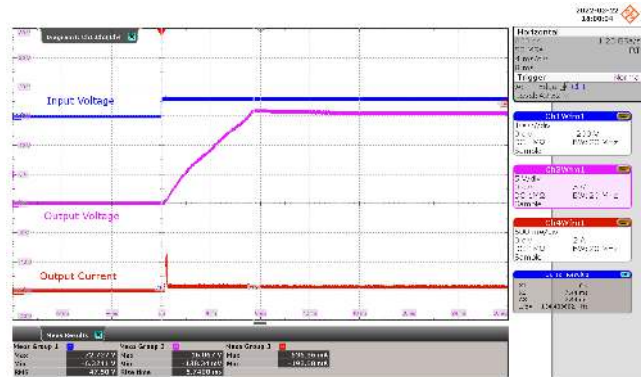

Figure 114 – 60 VDC Input. CC 10% Load.
 CH1: V_{INPUT} , 100 V / div., 4 ms / div.
 CH3: V_{OUT} , 5 V / div., 4 ms / div.
 CH4: I_{OUT} , 500 mA / div., 4 ms / div.
 Rise Time V_{OUT} = 5.748 ms.

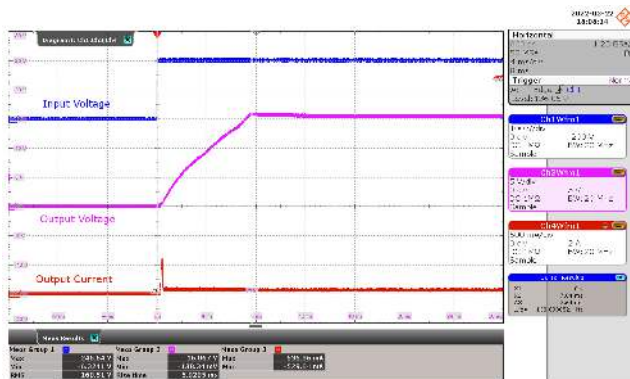

Figure 115 – 200 VDC Input. CC 10% Load.
 CH1: V_{INPUT} , 100 V / div., 4 ms / div.
 CH3: V_{OUT} , 5 V / div., 4 ms / div.
 CH4: I_{OUT} , 500 mA / div., 4 ms / div.
 Rise Time V_{OUT} = 5.928 ms.

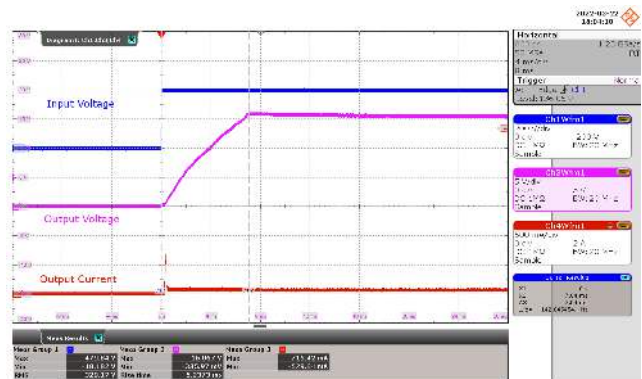

Figure 116 – 400 VDC Input. CC 10% Load.
 CH1: V_{INPUT} , 200 V / div., 4 ms / div.
 CH3: V_{OUT} , 5 V / div., 4 ms / div.
 CH4: I_{OUT} , 500 mA / div., 4 ms / div.
 Rise Time V_{OUT} = 5.2373 ms.

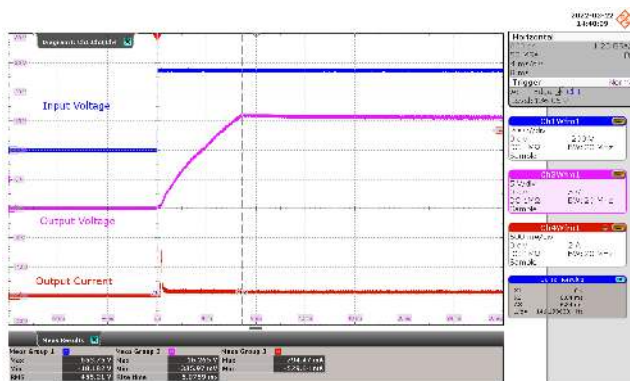

Figure 117 – 550 VDC Input. CC 10% Load.
 CH1: V_{INPUT} , 200 V / div., 4 ms / div.
 CH3: V_{OUT} , 5 V / div., 4 ms / div.
 CH4: I_{OUT} , 500 mA / div., 4 ms / div.
 Rise Time V_{OUT} = 5.075 ms.

10.3.2 Output Start-up 25 °C Ambient

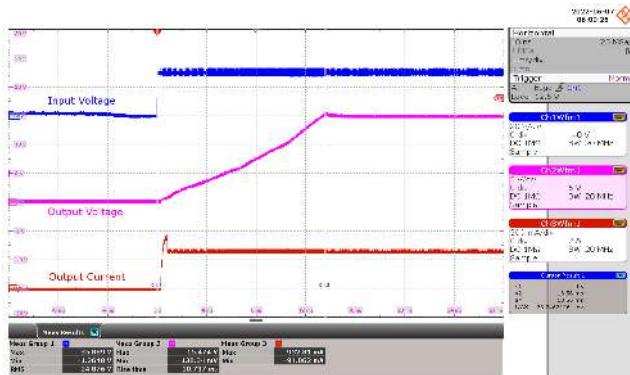

Figure 118 – 30 VDC Input. CC Full Load.
 CH1: V_{INPUT} , 20 V / div., 4 ms / div.
 CH3: V_{OUT} , 5 V / div., 4 ms / div.
 CH4: I_{OUT} , 500 mA / div., 4 ms / div.
 Rise Time V_{OUT} = 10.737 ms.

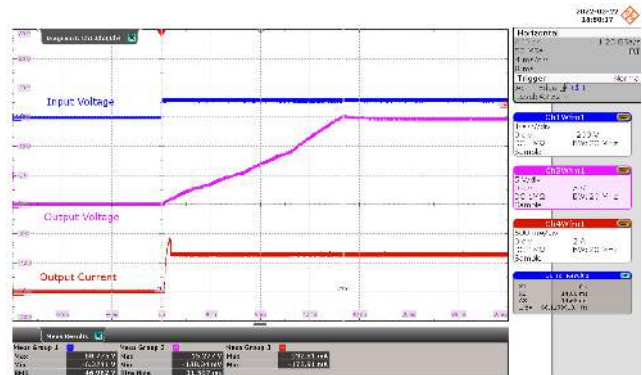

Figure 119 – 60 VDC Input. CC Full Load.
 CH1: V_{INPUT} , 100 V / div., 4 ms / div.
 CH3: V_{OUT} , 5 V / div., 4 ms / div.
 CH4: I_{OUT} , 500 mA / div., 4 ms / div.
 Rise Time V_{OUT} = 11.597 ms.

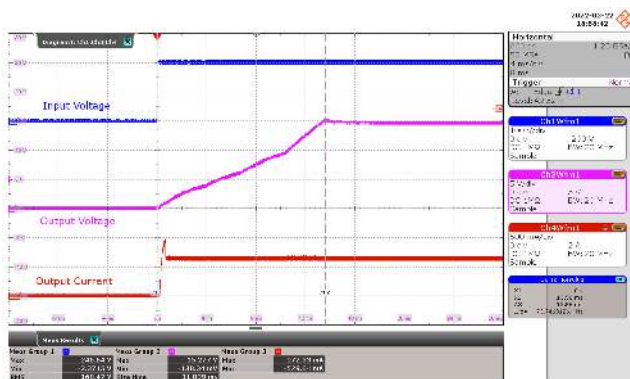

Figure 120 – 200 VDC Input. CC Full Load.
 CH1: V_{INPUT} , 100 V / div., 4 ms / div.
 CH3: V_{OUT} , 5 V / div., 4 ms / div.
 CH4: I_{OUT} , 500 mA / div., 4 ms / div.
 Rise Time V_{OUT} = 11.039 ms.

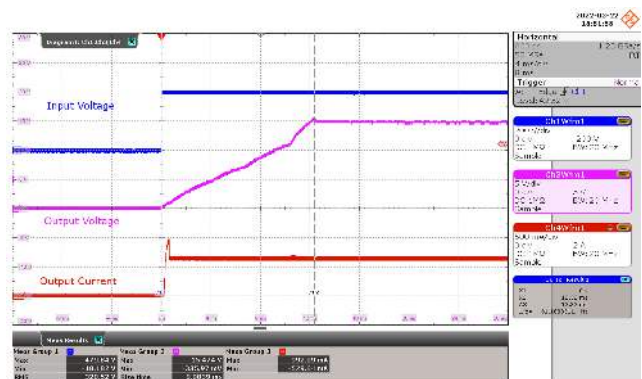

Figure 121 – 400 VDC Input. CC Full Load.
 CH1: V_{INPUT} , 200 V / div., 4 ms / div.
 CH3: V_{OUT} , 5 V / div., 4 ms / div.
 CH4: I_{OUT} , 500 mA / div., 4 ms / div.
 Rise Time V_{OUT} = 9.983 ms.

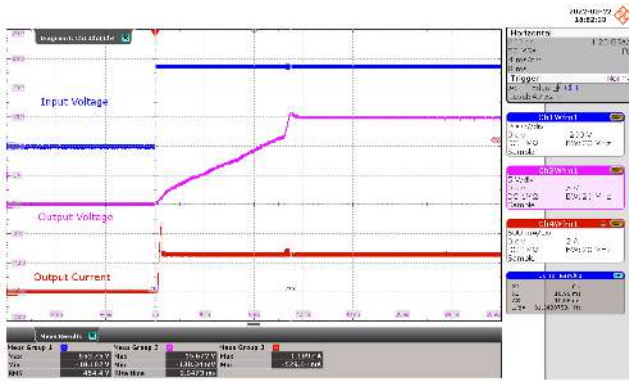

Figure 122 – 550 VDC Input. CC Full Load.
 CH1: V_{INPUT} , 200 V / div., 4 ms / div.
 CH3: V_{OUT} , 5 V / div., 4 ms / div.
 CH4: I_{OUT} , 500 mA / div., 4 ms / div.
 Rise Time V_{OUT} = 9.947 ms.

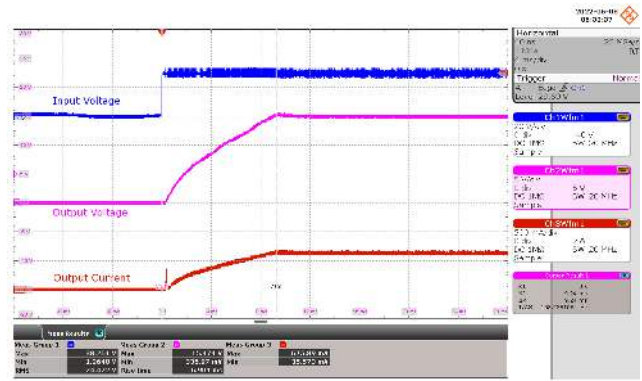

Figure 123 – 30 VDC Input. CR Full Load.
 CH1: V_{INPUT} , 20 V / div., 4 ms / div.
 CH3: V_{OUT} , 5 V / div., 4 ms / div.
 CH4: I_{OUT} , 500 mA / div., 4 ms / div.
 Rise Time V_{OUT} = 6.901 ms.

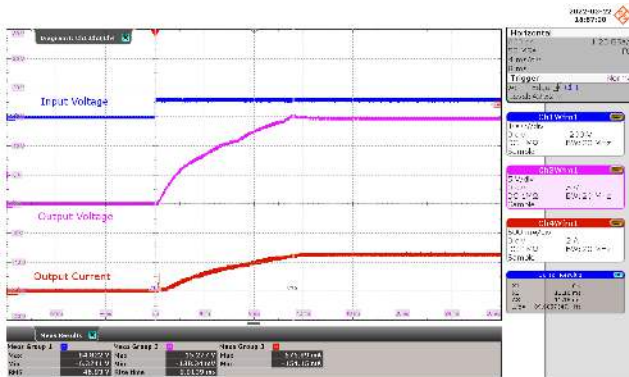

Figure 124 – 60 VDC Input. CR Full Load.
 CH1: V_{INPUT} , 100 V / div., 4 ms / div.
 CH3: V_{OUT} , 5 V / div., 4 ms / div.
 CH4: I_{OUT} , 500 mA / div., 4 ms / div.
 Rise Time V_{OUT} = 8.013 ms.

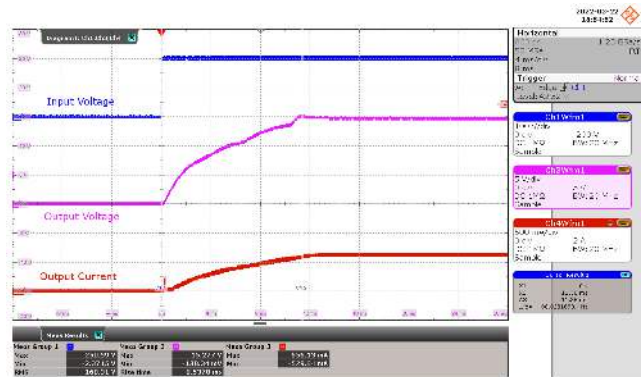

Figure 125 – 200 VDC Input. CR Full Load.
 CH1: V_{INPUT} , 100 V / div., 4 ms / div.
 CH3: V_{OUT} , 5 V / div., 4 ms / div.
 CH4: I_{OUT} , 500 mA / div., 4 ms / div.
 Rise Time V_{OUT} = 8.537 ms.

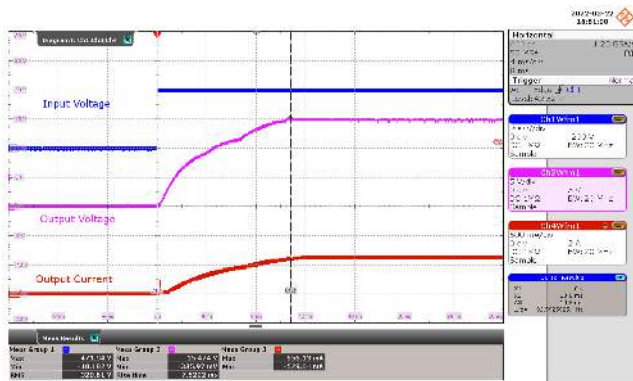

Figure 126 – 400 VDC Input. CR Full Load.
 CH1: V_{INPUT} , 200 V / div., 4 ms / div.
 CH3: V_{OUT} , 5 V / div., 4 ms / div.
 CH4: I_{OUT} , 500 mA / div., 4 ms / div.
 Rise Time V_{OUT} = 7.522 ms.

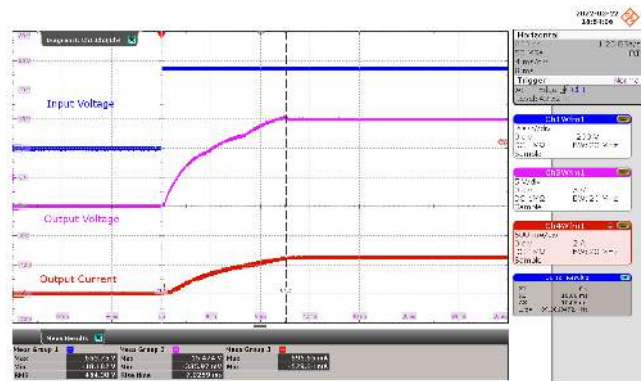

Figure 127 – 550 VDC Input. CR Full Load.
 CH1: V_{INPUT} , 200 V / div., 4 ms / div.
 CH3: V_{OUT} , 5 V / div., 4 ms / div.
 CH4: I_{OUT} , 500 mA / div., 4 ms / div.
 Rise Time V_{OUT} = 7.025 ms.

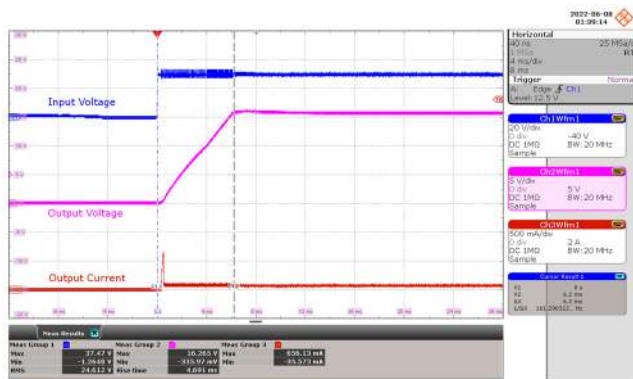

Figure 128 – 30 VDC Input. CC 10% Load.
 CH1: V_{INPUT} , 20 V / div., 4 ms / div.
 CH3: V_{OUT} , 5 V / div., 4 ms / div.
 CH4: I_{OUT} , 500 mA / div., 4 ms / div.
 Rise Time V_{OUT} = 4.691 ms.

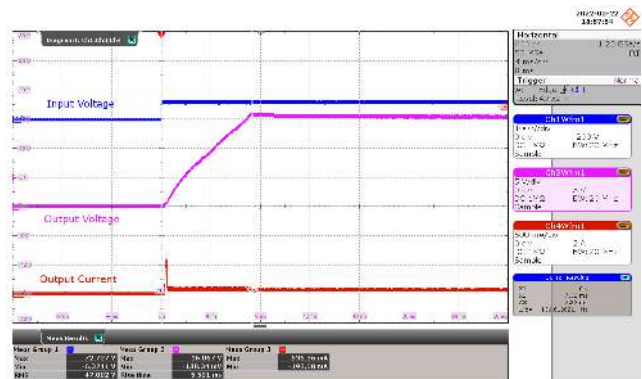

Figure 129 – 60 VDC Input. CC 10% Load.
 CH1: V_{INPUT} , 100 V / div., 4 ms / div.
 CH3: V_{OUT} , 5 V / div., 4 ms / div.
 CH4: I_{OUT} , 500 mA / div., 4 ms / div.
 Rise Time V_{OUT} = 5.581 ms.

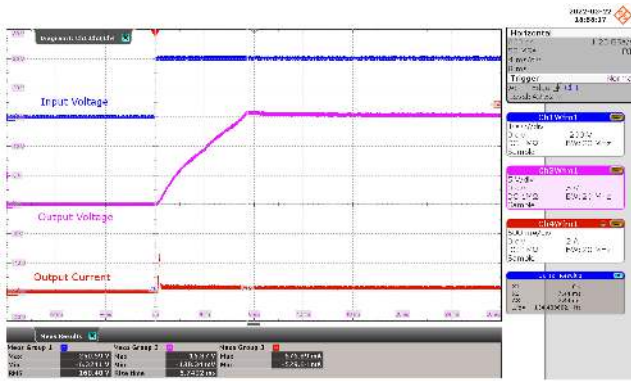

Figure 130 – 200 VDC Input. CC 10% Load.
 CH1: V_{INPUT} , 100 V / div., 4 ms / div.
 CH3: V_{OUT} , 5 V / div., 4 ms / div.
 CH4: I_{OUT} , 500 mA / div., 4 ms / div.
 Rise Time V_{OUT} = 5.743 ms.

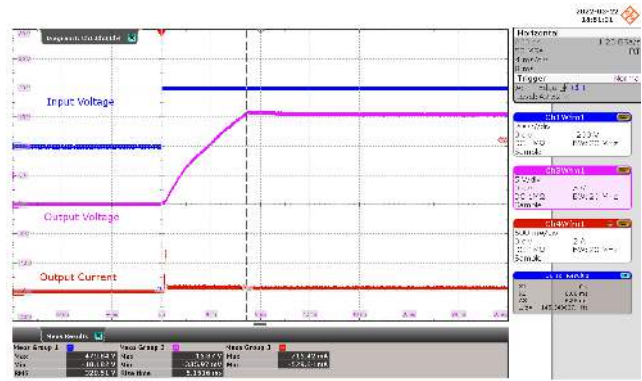

Figure 131 – 400 VDC Input. CC 10% Load.
 CH1: V_{INPUT} , 200 V / div., 4 ms / div.
 CH3: V_{OUT} , 5 V / div., 4 ms / div.
 CH4: I_{OUT} , 500 mA / div., 4 ms / div.
 Rise Time V_{OUT} = 5.151 ms.

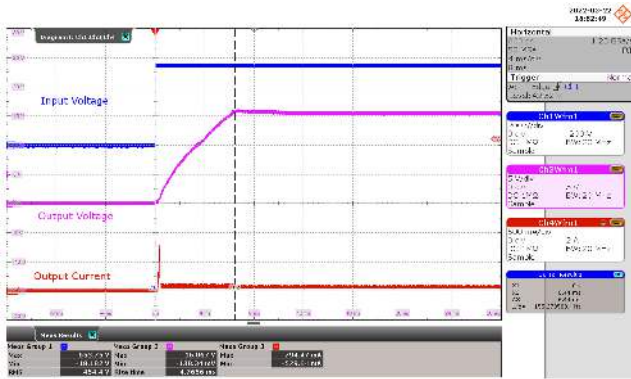

Figure 132 – 550 VDC Input. CC 10% Load.
 CH1: V_{INPUT} , 200 V / div., 4 ms / div.
 CH3: V_{OUT} , 5 V / div., 4 ms / div.
 CH4: I_{OUT} , 500 mA / div., 4 ms / div.
 Rise Time V_{OUT} = 4.765 ms.

10.3.3 Output Start-up -40 °C Ambient

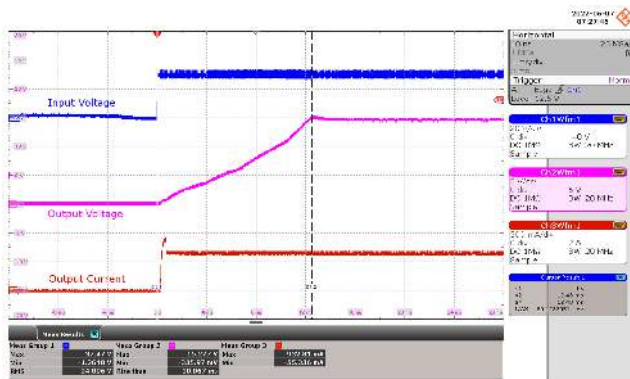

Figure 133 – 30 VDC Input. CC Full Load.
 CH1: V_{INPUT} , 20 V / div., 4 ms / div.
 CH3: V_{OUT} , 5 V / div., 4 ms / div.
 CH4: I_{OUT} , 500 mA / div., 4 ms / div.
 Rise Time V_{OUT} = 10.067 ms.

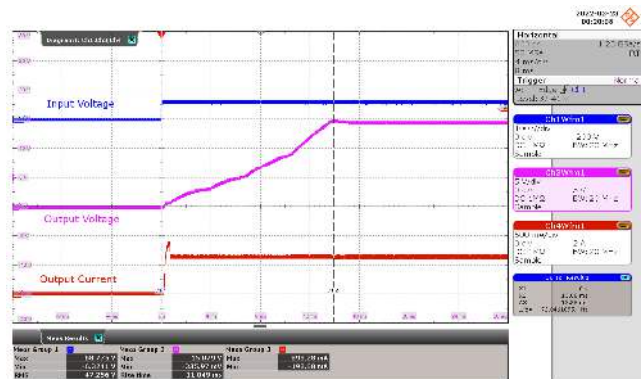

Figure 134 – 60 VDC Input. CC Full Load.
 CH1: V_{INPUT} , 100 V / div., 4 ms / div.
 CH3: V_{OUT} , 5 V / div., 4 ms / div.
 CH4: I_{OUT} , 500 mA / div., 4 ms / div.
 Rise Time V_{OUT} = 11.049 ms.

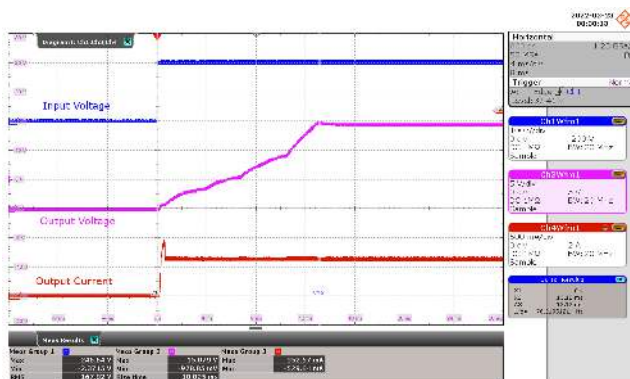

Figure 135 – 200 VDC Input. CC Full Load.
 CH1: V_{INPUT} , 100 V / div., 4 ms / div.
 CH3: V_{OUT} , 5 V / div., 4 ms / div.
 CH4: I_{OUT} , 500 mA / div., 4 ms / div.
 Rise Time V_{OUT} = 10.825 ms.

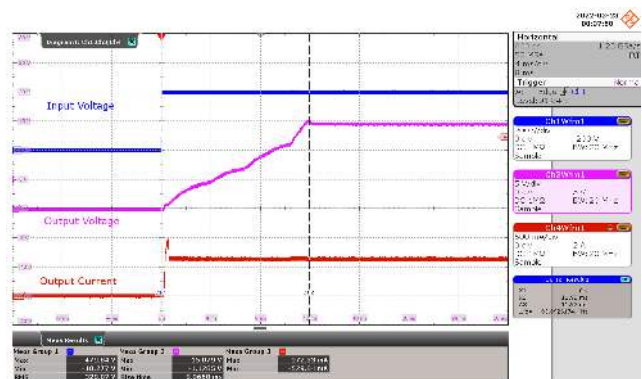

Figure 136 – 400 VDC Input. CC Full Load.
 CH1: V_{INPUT} , 200 V / div., 4 ms / div.
 CH3: V_{OUT} , 5 V / div., 4 ms / div.
 CH4: I_{OUT} , 500 mA / div., 4 ms / div.
 Rise Time V_{OUT} = 9.966 ms.

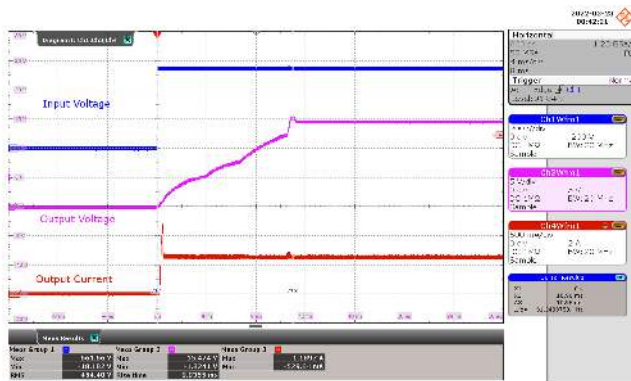

Figure 137 – 550 VDC Input. CC Full Load.
 CH1: V_{INPUT} , 200 V / div., 4 ms / div.
 CH3: V_{OUT} , 5 V / div., 4 ms / div.
 CH4: I_{OUT} , 500 mA / div., 4 ms / div.
 Rise Time V_{OUT} = 9.935 ms.

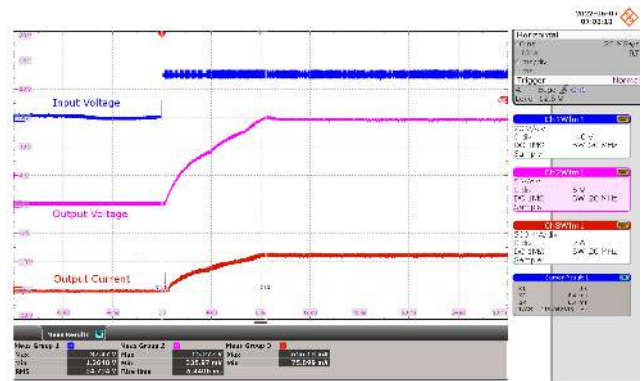

Figure 138 – 30 VDC Input. CR Full Load.
 CH1: V_{INPUT} , 20 V / div., 4 ms / div.
 CH3: V_{OUT} , 5 V / div., 4 ms / div.
 CH4: I_{OUT} , 500 mA / div., 4 ms / div.
 Rise Time V_{OUT} = 6.4406 ms.

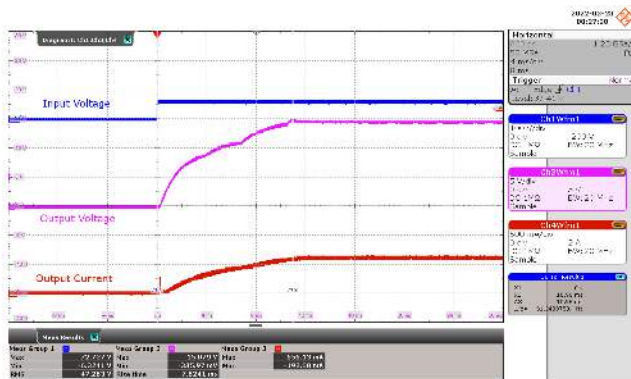

Figure 139 – 60 VDC Input. CR Full Load.
 CH1: V_{INPUT} , 100 V / div., 4 ms / div.
 CH3: V_{OUT} , 5 V / div., 4 ms / div.
 CH4: I_{OUT} , 500 mA / div., 4 ms / div.
 Rise Time V_{OUT} = 7.624 ms.

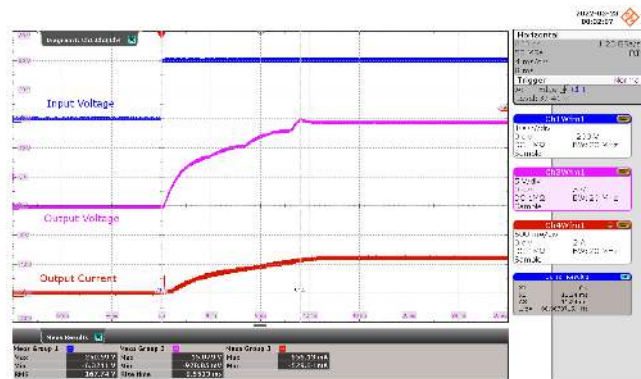

Figure 140 – 200 VDC Input. CR Full Load.
 CH1: V_{INPUT} , 100 V / div., 4 ms / div.
 CH3: V_{OUT} , 5 V / div., 4 ms / div.
 CH4: I_{OUT} , 500 mA / div., 4 ms / div.
 Rise Time V_{OUT} = 8.551 ms.

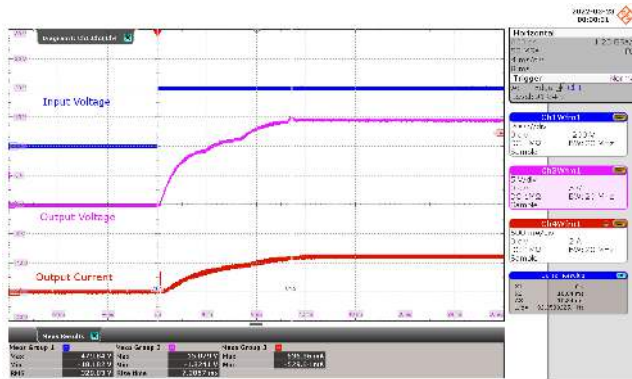

Figure 141 – 400 VDC Input. CR Full Load.
 CH1: V_{INPUT} , 200 V / div., 4 ms / div.
 CH3: V_{OUT} , 5 V / div., 4 ms / div.
 CH4: I_{OUT} , 500 mA / div., 4 ms / div.
 Rise Time V_{OUT} = 7.205 ms.

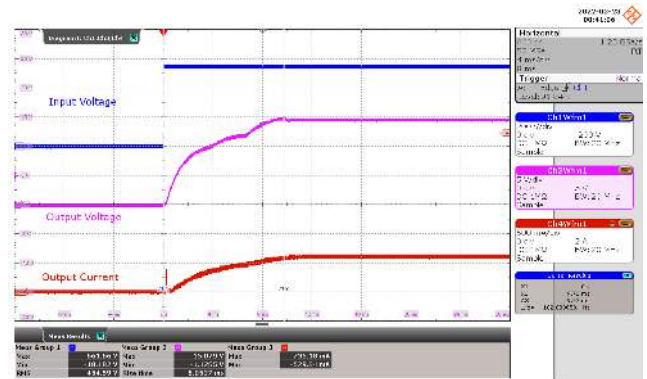

Figure 142 – 550 VDC Input. CR Full Load.
 CH1: V_{INPUT} , 200 V / div., 4 ms / div.
 CH3: V_{OUT} , 5 V / div., 4 ms / div.
 CH4: I_{OUT} , 500 mA / div., 4 ms / div.
 Rise Time V_{OUT} = 6.853 ms.

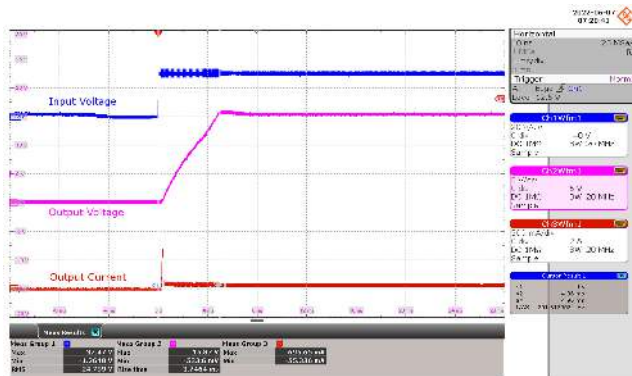

Figure 143 – 30 VDC Input. CC 10% Load.
 CH1: V_{INPUT} , 20 V / div., 4 ms / div.
 CH3: V_{OUT} , 5 V / div., 4 ms / div.
 CH4: I_{OUT} , 500 mA / div., 4 ms / div.
 Rise Time V_{OUT} = 3.7464 ms.

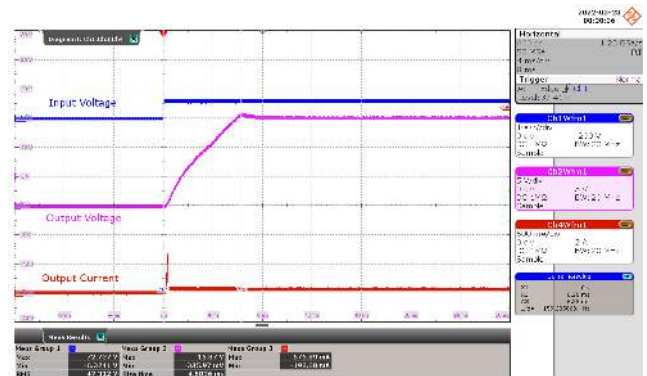

Figure 144 – 60 VDC Input. CC 10% Load.
 CH1: V_{INPUT} , 100 V / div., 4 ms / div.
 CH3: V_{OUT} , 5 V / div., 4 ms / div.
 CH4: I_{OUT} , 500 mA / div., 4 ms / div.
 Rise Time V_{OUT} = 4.603 ms.

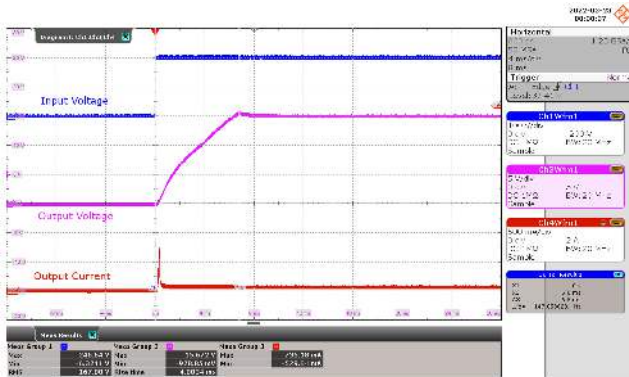

Figure 145 – 200 VDC Input. CC 10% Load.
 CH1: V_{INPUT} , 100 V / div., 4 ms / div.
 CH3: V_{OUT} , 5 V / div., 4 ms / div.
 CH4: I_{OUT} , 500 mA / div., 4 ms / div.
 Rise Time V_{OUT} = 4.803 ms.

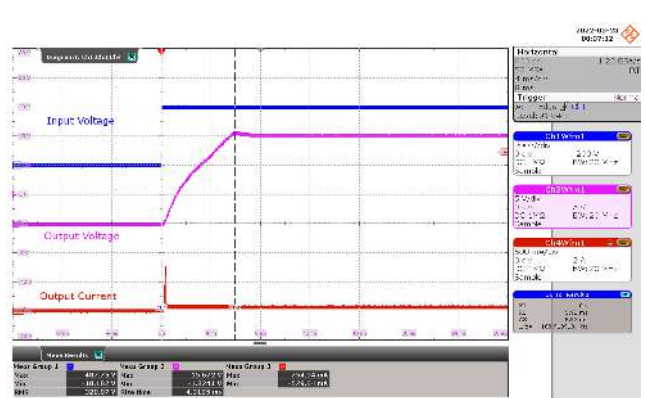

Figure 146 – 400 VDC Input. CC 10% Load.
 CH1: V_{INPUT} , 200 V / div., 4 ms / div.
 CH3: V_{OUT} , 5 V / div., 4 ms / div.
 CH4: I_{OUT} , 500 mA / div., 4 ms / div.
 Rise Time V_{OUT} = 4.310 ms.

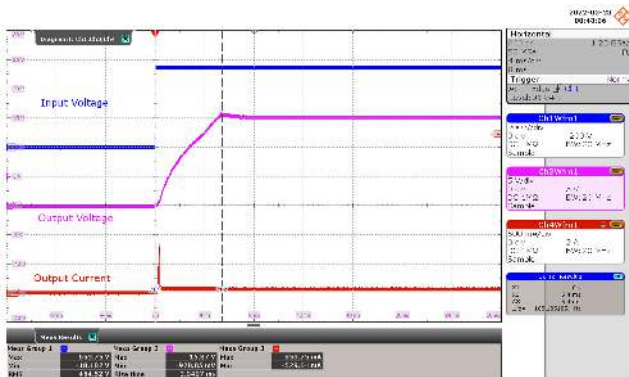

Figure 147 – 550 VDC Input. CC 10% Load.
 CH1: V_{INPUT} , 200 V / div., 4 ms / div.
 CH3: V_{OUT} , 5 V / div., 4 ms / div.
 CH4: I_{OUT} , 500 mA / div., 4 ms / div.
 Rise Time V_{OUT} = 3.940 ms.

10.4 Fault Conditions

10.4.1 15 V Output Short-Circuit

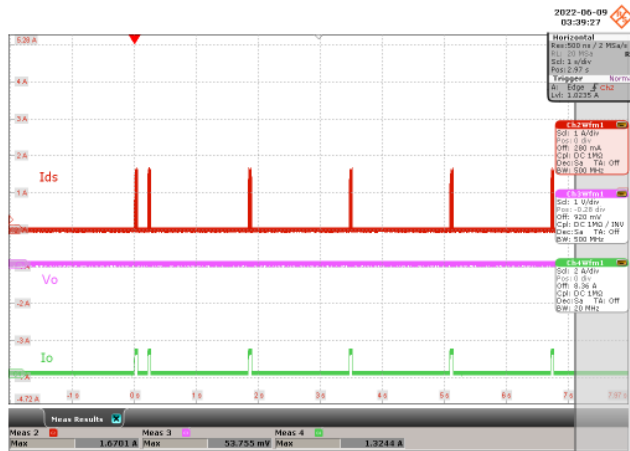

Figure 148 – 30 VDC Input. Output Short.
 CH2: I_{DS} , 1 A / div., 1 s / div.
 CH3: V_{OUT} , 1 V / div., 1 s / div.
 CH4: I_{OUT} , 2 A / div., 1 s / div.
 $V_{OUT(MAX)} = 53.755$ mV.
 $I_{OUT(MAX)} = 1.3244$ A.
 $I_{DS(MAX)} = 1.6701$ A.

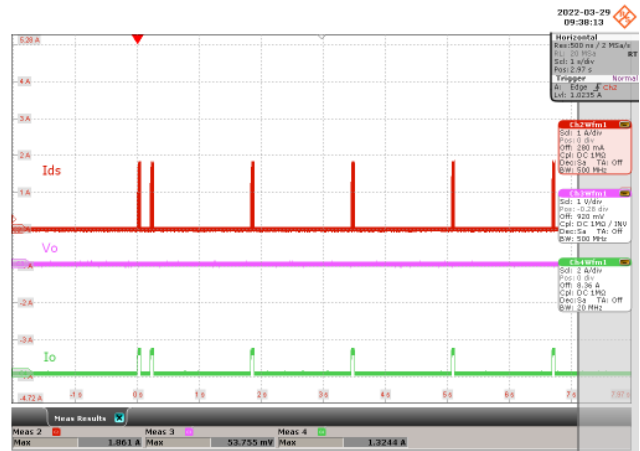

Figure 149 – 60 VDC Input. Output Short.
 CH2: I_{DS} , 1 A / div., 1 s / div.
 CH3: V_{OUT} , 1 V / div., 1 s / div.
 CH4: I_{OUT} , 2 A / div., 1 s / div.
 $V_{OUT(MAX)} = 53.755$ mV.
 $I_{OUT(MAX)} = 1.3244$ A.
 $I_{DS(MAX)} = 1.861$ A.

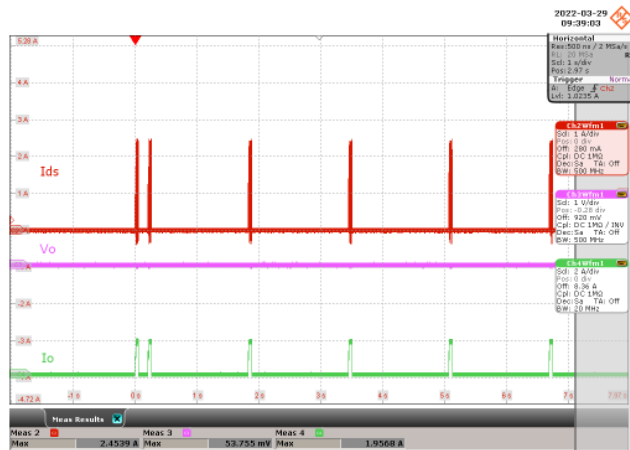

Figure 150 – 100 VDC Input. Output Short.
 CH2: I_{DS} , 1 A / div., 1 s / div.
 CH3: V_{OUT} , 1 V / div., 1 s / div.
 CH4: I_{OUT} , 2 A / div., 1 s / div.
 $V_{OUT(MAX)} = 53.755$ mV.
 $I_{OUT(MAX)} = 1.9568$ A.
 $I_{DS(MAX)} = 2.4539$ A.

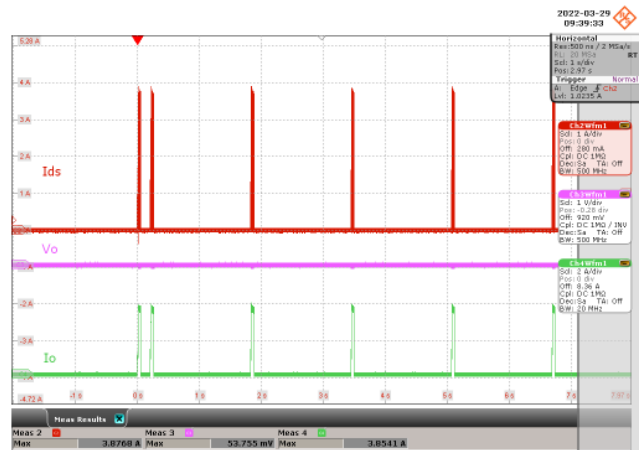

Figure 151 – 200 VDC Input. Output Short.
 CH2: I_{DS} , 1 A / div., 1 s / div.
 CH3: V_{OUT} , 1 V / div., 1 s / div.
 CH4: I_{OUT} , 2 A / div., 1 s / div.
 $V_{OUT(MAX)} = 53.755$ mV.
 $I_{OUT(MAX)} = 3.8541$ A.
 $I_{DS(MAX)} = 3.8768$ A.

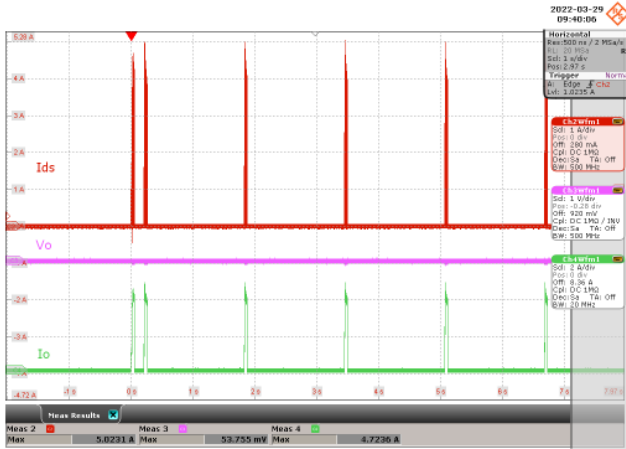

Figure 152 – 300 VDC Input. Output Short.
 CH2: I_{DS} , 1 A / div., 1 s / div.
 CH3: V_{OUT} , 1 V / div., 1 s / div.
 CH4: I_{OUT} , 2 A / div., 1 s / div.
 $V_{OUT(MAX)}$ = 53.755 mV.
 $I_{OUT(MAX)}$ = 4.7236 A.
 $I_{DS(MAX)}$ = 5.0231 A.

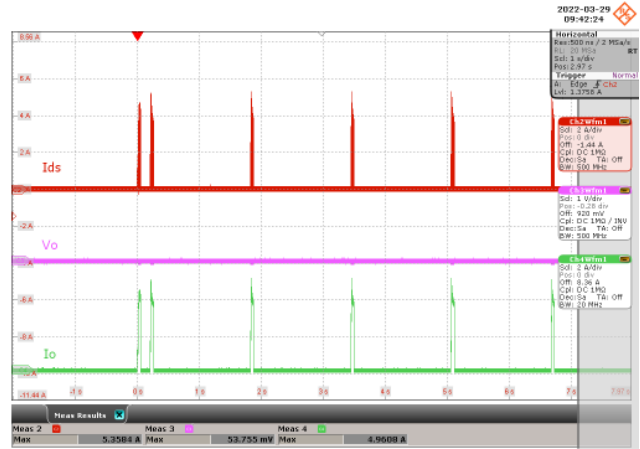

Figure 153 – 400 VDC Input. Output Short.
 CH2: I_{DS} , 2 A / div., 1 s / div.
 CH3: V_{OUT} , 1 V / div., 1 s / div.
 CH4: I_{OUT} , 2 A / div., 1 s / div.
 $V_{OUT(MAX)}$ = 53.755 mV.
 $I_{OUT(MAX)}$ = 4.9608 A.
 $I_{DS(MAX)}$ = 5.3584 A.

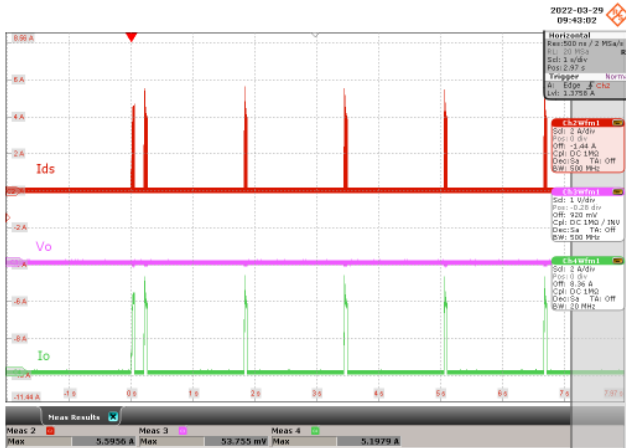

Figure 154 – 500 VDC Input. Output Short.
 CH2: I_{DS} , 2 A / div., 1 s / div.
 CH3: V_{OUT} , 1 V / div., 1 s / div.
 CH4: I_{OUT} , 2 A / div., 1 s / div.
 $V_{OUT(MAX)}$ = 53.755 mV.
 $I_{OUT(MAX)}$ = 5.1979 A.
 $I_{DS(MAX)}$ = 5.5956 A.

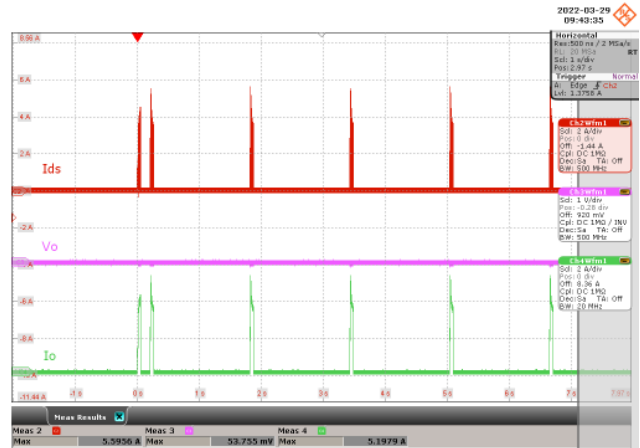

Figure 155 – 550 VDC Input. Output Short.
 CH2: I_{DS} , 2 A / div., 1 s / div.
 CH3: V_{OUT} , 1 V / div., 1 s / div.
 CH4: I_{OUT} , 2 A / div., 1 s / div.
 $V_{OUT(MAX)}$ = 53.755 mV.
 $I_{OUT(MAX)}$ = 5.1979 A.
 $I_{DS(MAX)}$ = 5.5956 A.

10.5 Output Voltage Ripple

10.5.1 Ripple Measurement Technique

For DC output ripple measurements, a modified oscilloscope test probe must be utilized to reduce spurious signals due to pick-up. Details of the probe modification are provided in the Figures below.

The 4987BA probe adapter is affixed with two capacitors tied in parallel across the probe tip. The capacitors include one (1) 0.1 μF / 50 V ceramic type and one (1) 47 μF / 50 V aluminum electrolytic. The aluminum electrolytic type capacitor is polarized, so proper polarity across DC outputs must be maintained (see below).

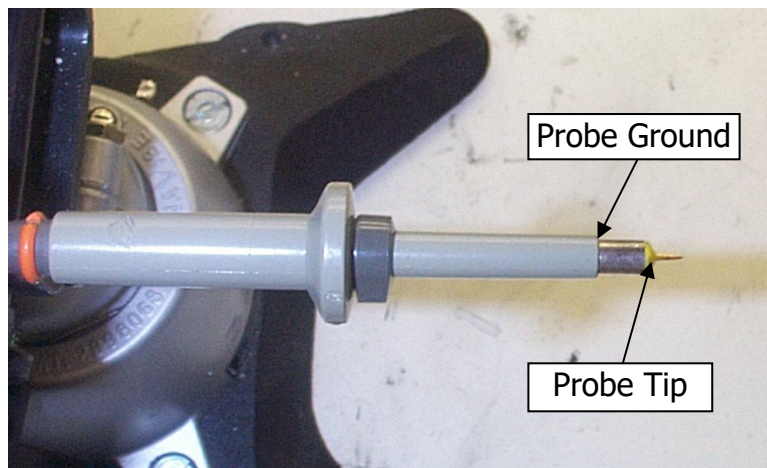

Figure 156 – Oscilloscope Probe Prepared for Ripple Measurement. (End Cap and Ground Lead Removed.)

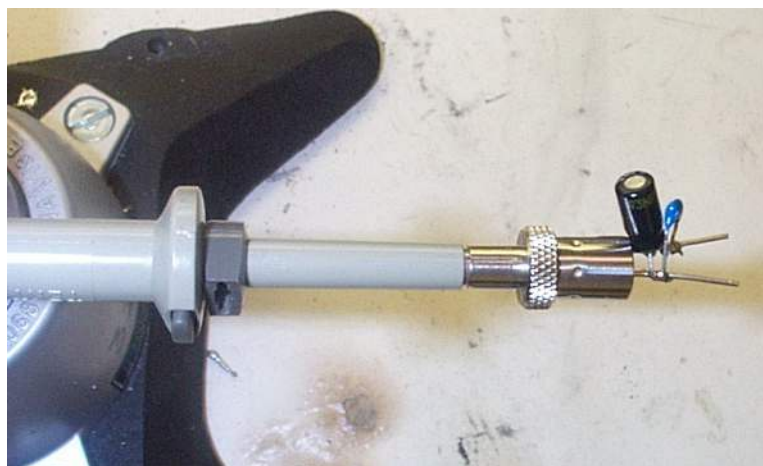

Figure 157 – Oscilloscope Probe with Probe Master (www.probemaster.com) 4987A BNC Adapter. (Modified with wires for ripple measurement, and two parallel decoupling capacitors added.)

10.5.2 Measurement Results

Note: All ripple measurements were taken at PCB end.

10.5.2.1 100% Load Condition

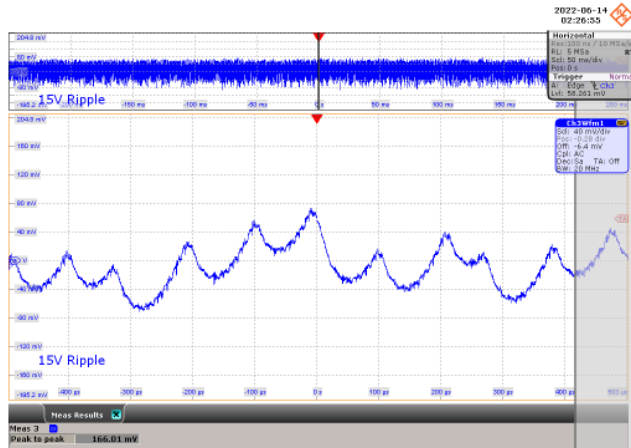

Figure 158 – 30 VDC Input.
 CH3: V_{OUT} , 40 mV / div., 50 ms / div.
 Zoom: 100 μ s / div.
 15 V Output Ripple = 166.01 mV.

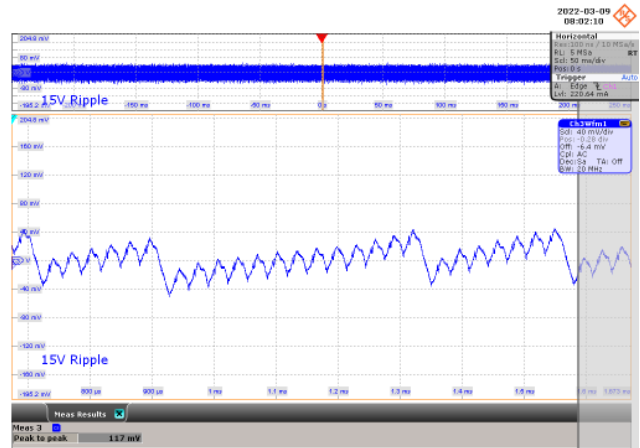

Figure 159 – 60 VDC Input.
 CH3: V_{OUT} , 40 mV / div., 50 ms / div.
 Zoom: 100 μ s / div.
 15 V Output Ripple = 117 mV.

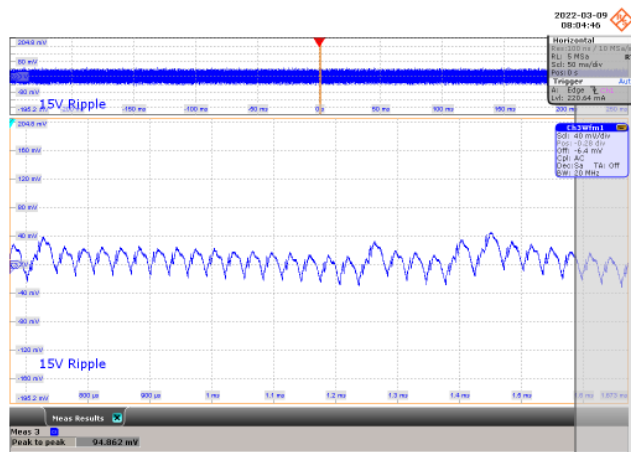

Figure 160 – 100 VDC Input.
 CH3: V_{OUT} , 40 mV / div., 50 ms / div.
 Zoom: 100 μ s / div.
 15 V Output Ripple = 94.862 mV.

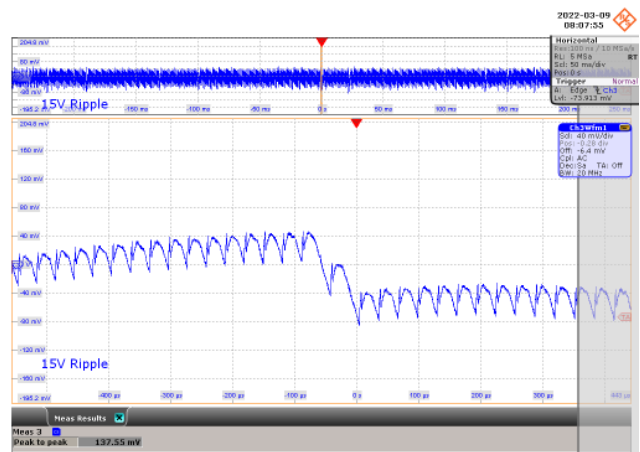

Figure 161 – 200 VDC Input.
 CH3: V_{OUT} , 40 mV / div., 50 ms / div.
 Zoom: 100 μ s / div.
 15 V Output Ripple = 137.55 mV.

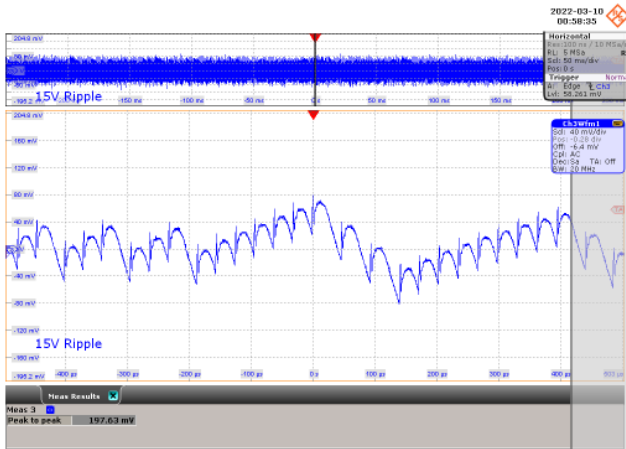

Figure 162 – 300 VDC Input.
 CH3: V_{OUT} , 40 mV / div., 50 ms / div.
 Zoom: 100 μ s / div.
 15 V Output Ripple = 197.63 mV.

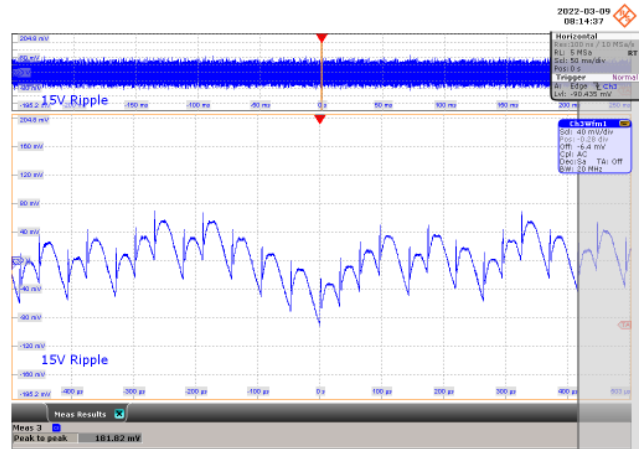

Figure 163 – 400 VDC Input.
 CH3: V_{OUT} , 40 mV / div., 50 ms / div.
 Zoom: 100 μ s / div.
 15 V Output Ripple = 181.82 mV.

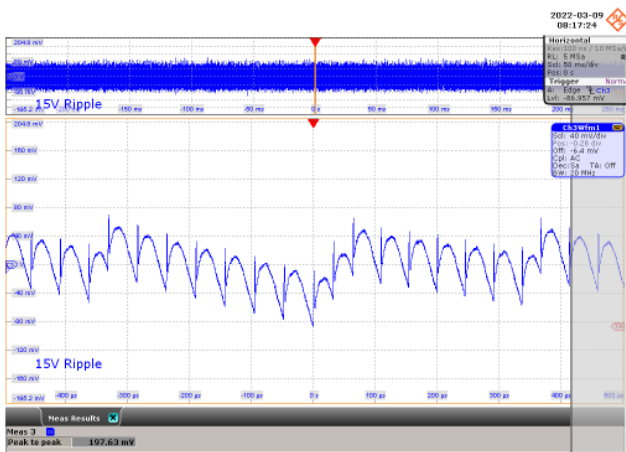

Figure 164 – 500 VDC Input.
 CH3: V_{OUT} , 40 mV / div., 50 ms / div.
 Zoom: 100 μ s / div.
 15 V Output Ripple = 197.63 mV.

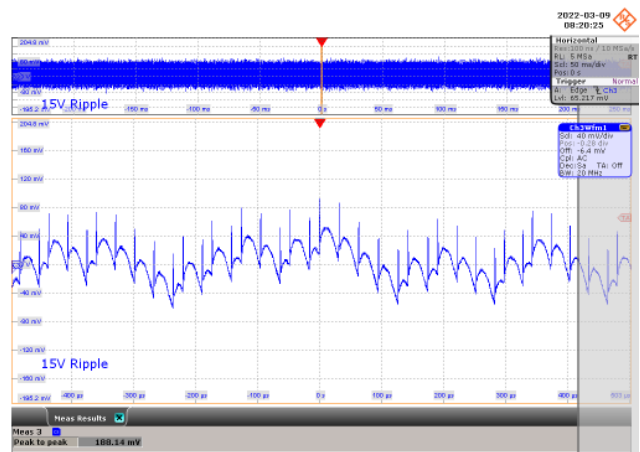

Figure 165 – 550 VDC Input.
 CH3: V_{OUT} , 40 mV / div., 50 ms / div.
 Zoom: 100 μ s / div.
 15 V Output Ripple = 188.14 mV.

10.5.2.2 75% Load Condition

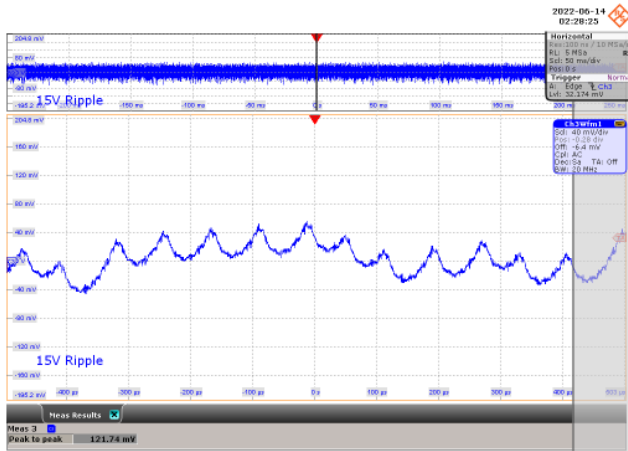

Figure 166 – 30 VDC Input.
 CH3: V_{OUT} , 40 mV / div., 50 ms / div.
 Zoom: 100 μ s / div.
 15 V Output Ripple = 121.74 mV.

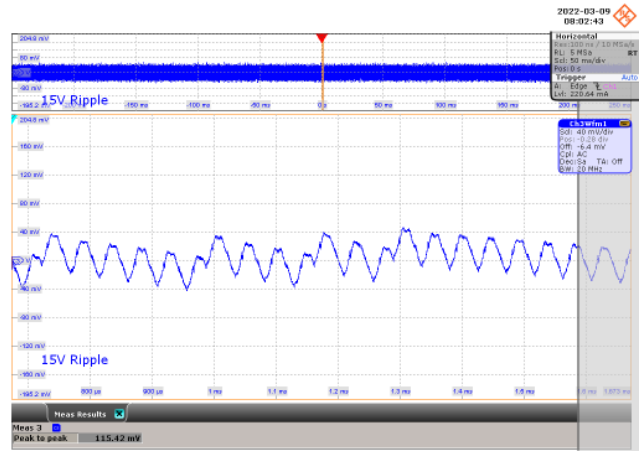

Figure 167 – 60 VDC Input.
 CH3: V_{OUT} , 40 mV / div., 50 ms / div.
 Zoom: 100 μ s / div.
 15 V Output Ripple = 115.42 mV.

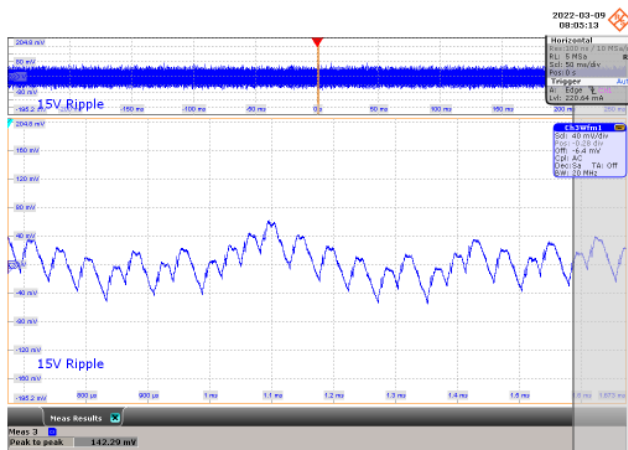

Figure 168 – 100 VDC Input.
 CH3: V_{OUT} , 40 mV / div., 50 ms / div.
 Zoom: 100 μ s / div.
 15 V Output Ripple = 142.29 mV.

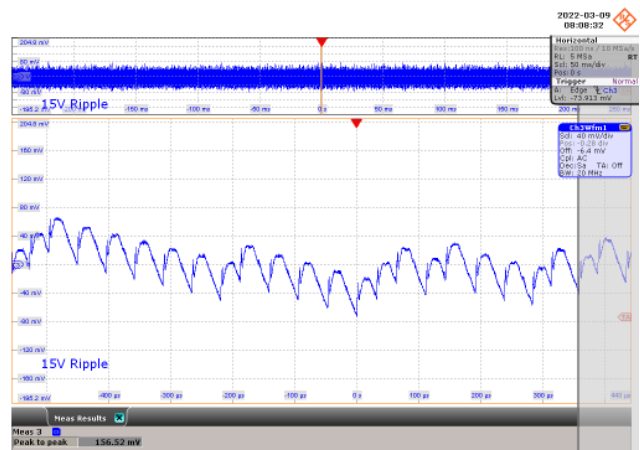

Figure 169 – 200 VDC Input.
 CH3: V_{OUT} , 40 mV / div., 50 ms / div.
 Zoom: 100 μ s / div.
 15 V Output Ripple = 156.52 mV.

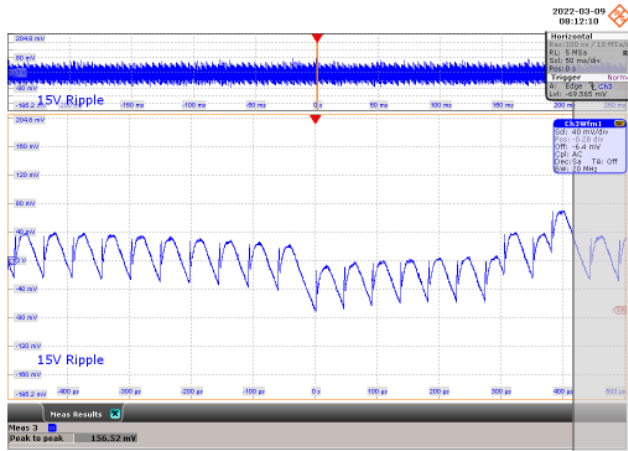

Figure 170 – 300 VDC Input.
 CH3: V_{OUT} , 40 mV / div., 50 ms / div.
 Zoom: 100 μ s / div.
 15 V Output Ripple = 156.52 mV.

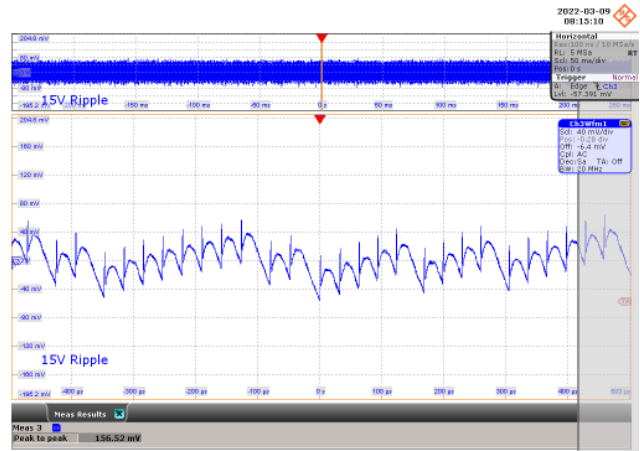

Figure 171 – 400 VDC Input.
 CH3: V_{OUT} , 40 mV / div., 50 ms / div.
 Zoom: 100 μ s / div.
 15 V Output Ripple = 156.52 mV.

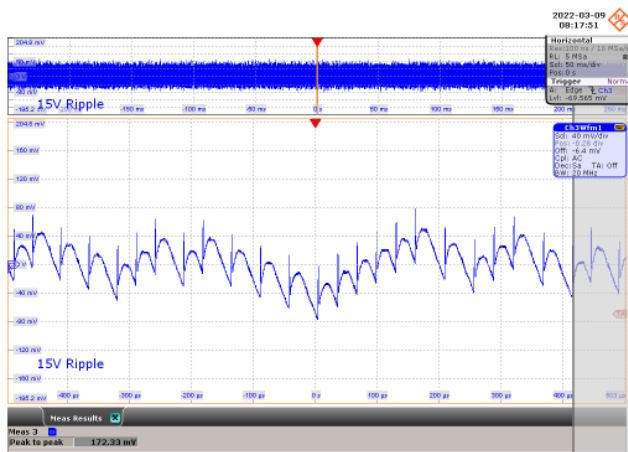

Figure 172 – 500 VDC Input.
 CH3: V_{OUT} , 40 mV / div., 50 ms / div.
 Zoom: 100 μ s / div.
 15 V Output Ripple = 172.33 mV.

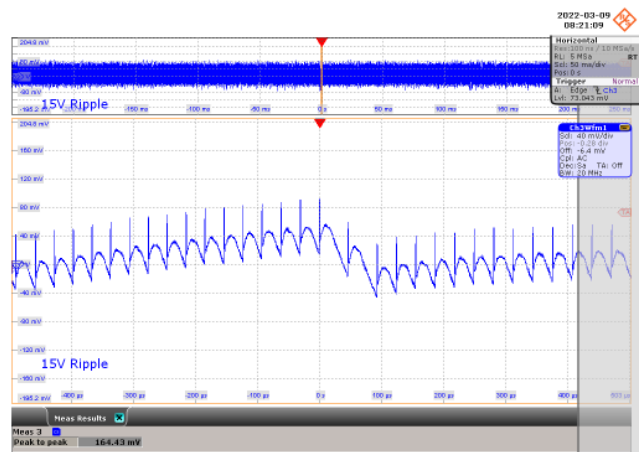

Figure 173 – 550 VDC Input.
 CH3: V_{OUT} , 40 mV / div., 50 ms / div.
 Zoom: 100 μ s / div.
 15 V Output Ripple = 164.43 mV.

10.5.2.3 50% Load Condition

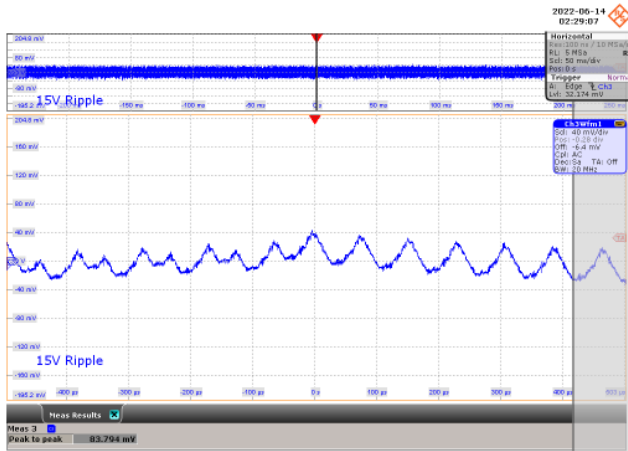

Figure 174 – 30 VDC Input.
 CH3: V_{OUT} , 40 mV / div., 50 ms / div.
 Zoom: 100 μ s / div.
 15 V Output Ripple = 83.794 mV.

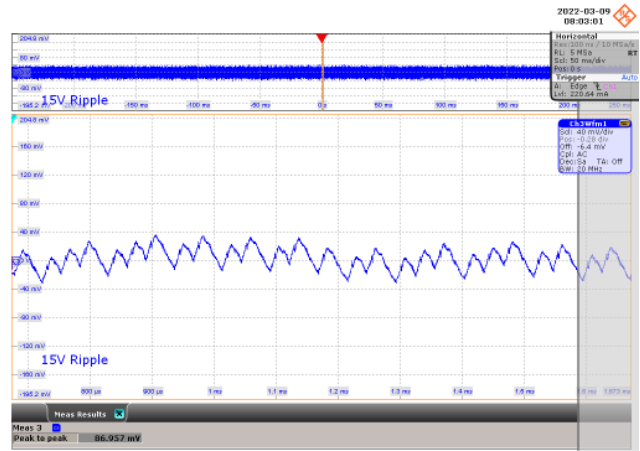

Figure 175 – 60 VDC Input.
 CH3: V_{OUT} , 40 mV / div., 50 ms / div.
 Zoom: 100 μ s / div.
 15 V Output Ripple = 86.957 mV.

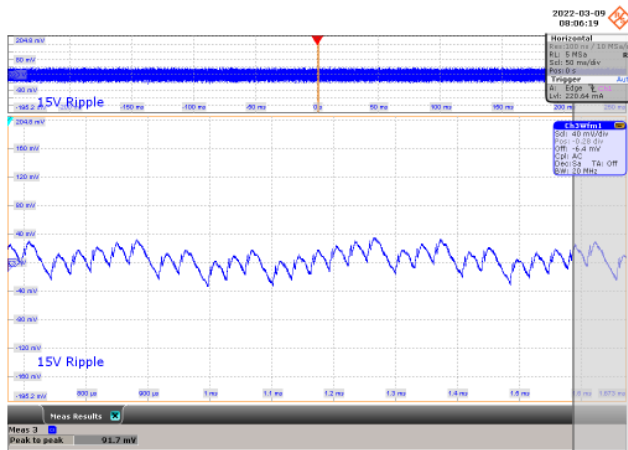

Figure 176 – 100 VDC Input.
 CH3: V_{OUT} , 40 mV / div., 50 ms / div.
 Zoom: 100 μ s / div.
 15 V Output Ripple = 91.7 mV.

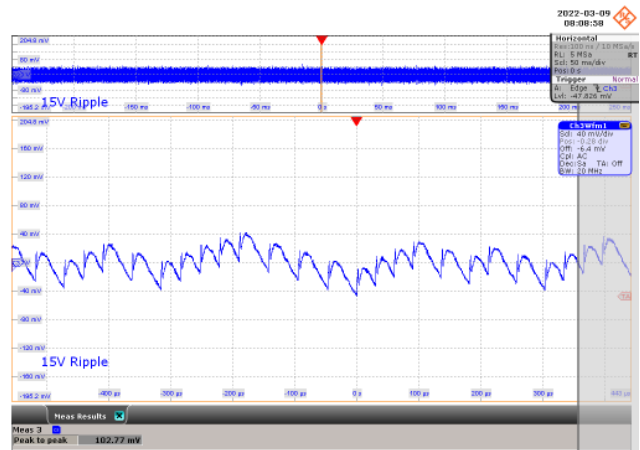

Figure 177 – 200 VDC Input.
 CH3: V_{OUT} , 40 mV / div., 50 ms / div.
 Zoom: 100 μ s / div.
 15 V Output Ripple = 102.77 mV.

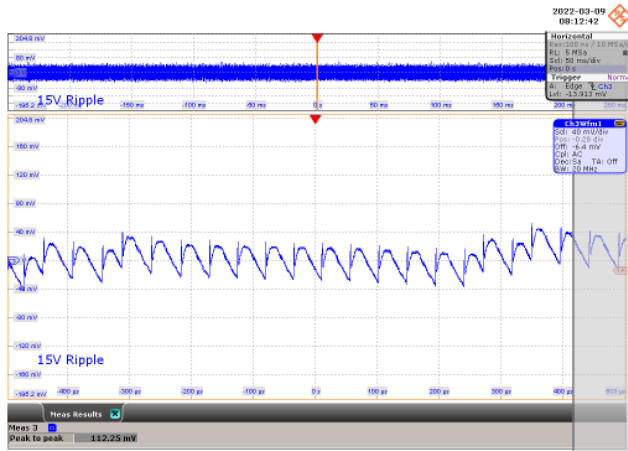

Figure 178 – 300 VDC Input.
 CH3: V_{OUT} , 40 mV / div., 50 ms / div.
 Zoom: 100 μ s / div.
 15 V Output Ripple = 112.25 mV.

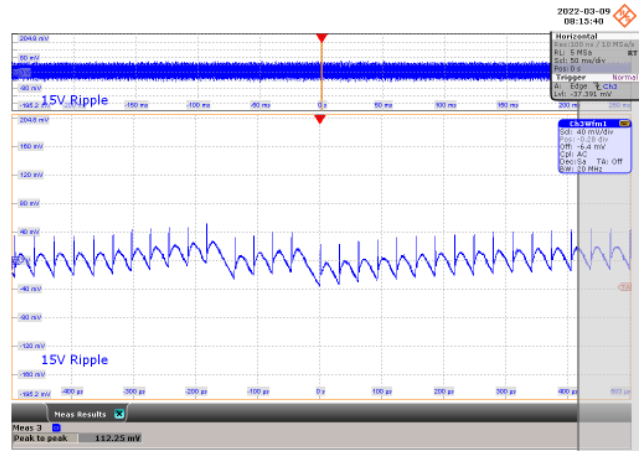

Figure 179 – 400 VDC Input.
 CH3: V_{OUT} , 40 mV / div., 50 ms / div.
 Zoom: 100 μ s / div.
 15 V Output Ripple = 112.25 mV.

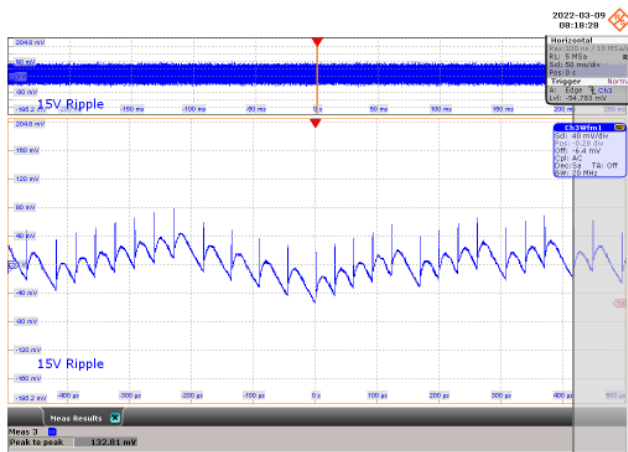

Figure 180 – 500 VDC Input.
 CH3: V_{OUT} , 40 mV / div., 50 ms / div.
 Zoom: 100 μ s / div.
 15 V Output Ripple = 132.81 mV.

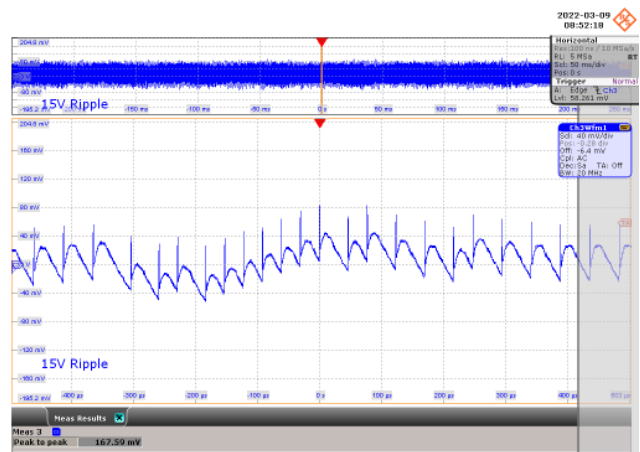

Figure 181 – 550 VDC Input.
 CH3: V_{OUT} , 40 mV / div., 50 ms / div.
 Zoom: 100 μ s / div.
 15 V Output Ripple = 167.59 mV.

10.5.2.4 25% Load Condition

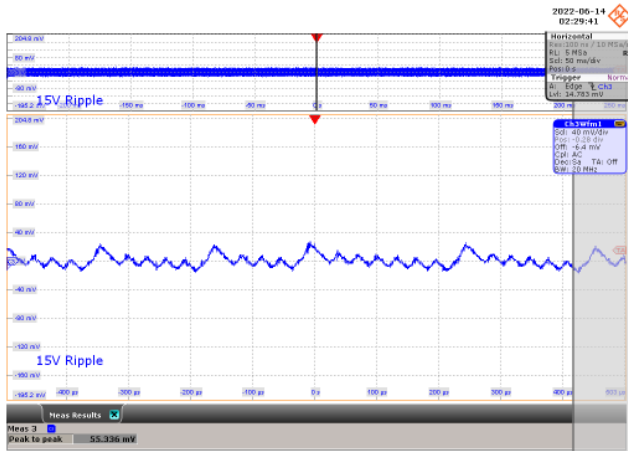

Figure 182 – 30 VDC Input.
 CH3: V_{OUT} , 40 mV / div., 50 ms / div.
 Zoom: 100 μ s / div.
 15 V Output Ripple = 55.336 mV.

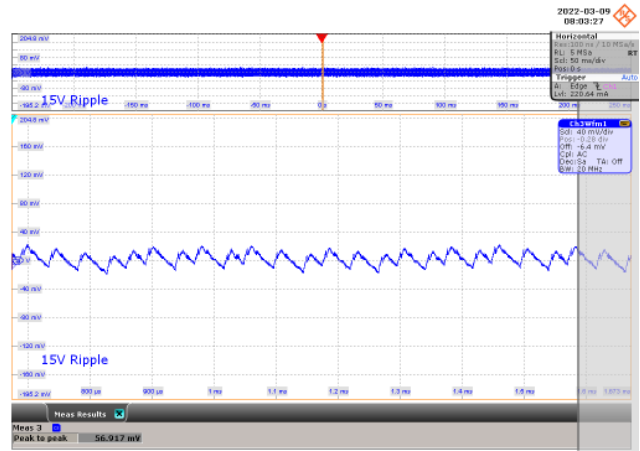

Figure 183 – 60 VDC Input.
 CH3: V_{OUT} , 40 mV / div., 50 ms / div.
 Zoom: 100 μ s / div.
 15 V Output Ripple = 56.917 mV.

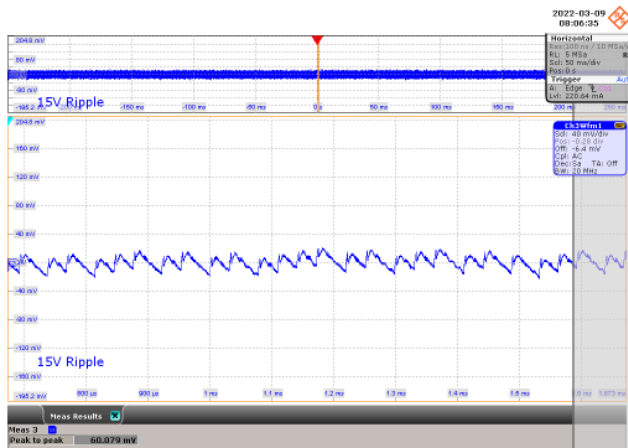

Figure 184 – 100 VDC Input.
 CH3: V_{OUT} , 40 mV / div., 50 ms / div.
 Zoom: 100 μ s / div.
 15 V Output Ripple = 60.079 mV.

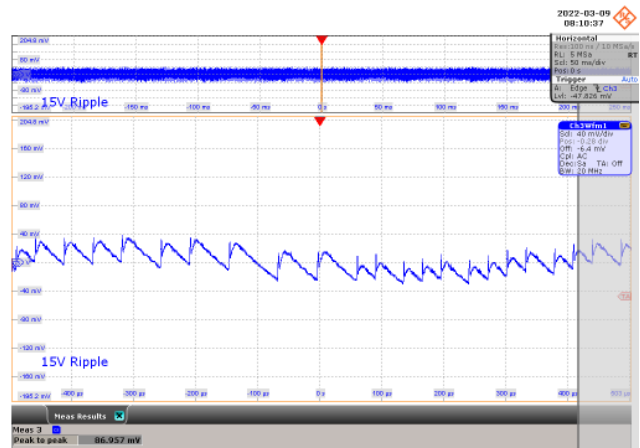

Figure 185 – 200 VDC Input.
 CH3: V_{OUT} , 40 mV / div., 50 ms / div.
 Zoom: 100 μ s / div.
 15 V Output Ripple = 86.957 mV.

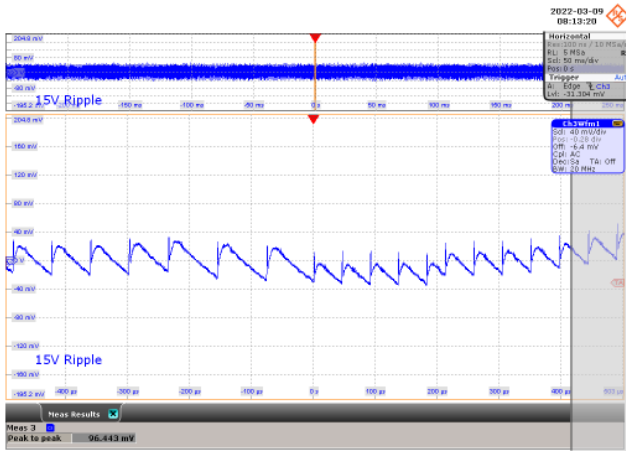

Figure 186 – 300 VDC Input.
 CH3: V_{OUT} , 40 mV / div., 50 ms / div.
 Zoom: 100 μ s / div.
 15 V Output Ripple = 96.443 mV.

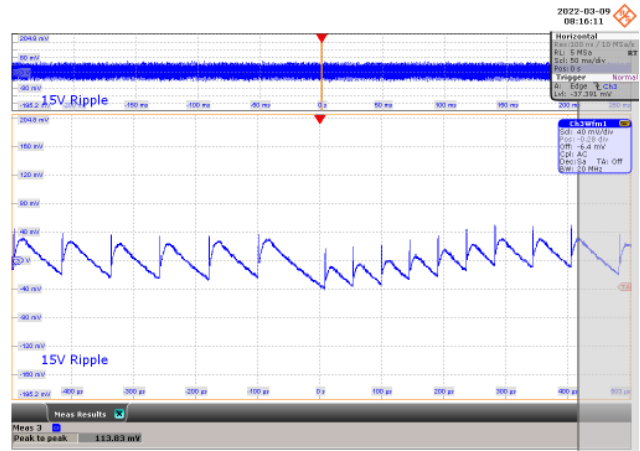

Figure 187 – 400 VDC Input.
 CH3: V_{OUT} , 40 mV / div., 50 ms / div.
 Zoom: 100 μ s / div.
 15 V Output Ripple = 113.83 mV.

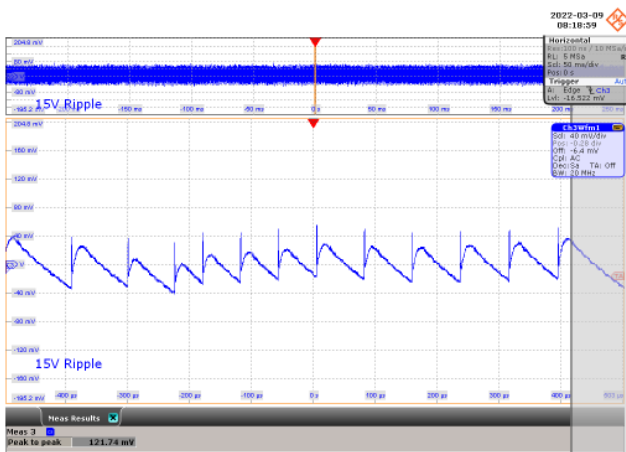

Figure 188 – 500 VDC Input.
 CH3: V_{OUT} , 40 mV / div., 50 ms / div.
 Zoom: 100 μ s / div.
 15 V Output Ripple = 121.74 mV.

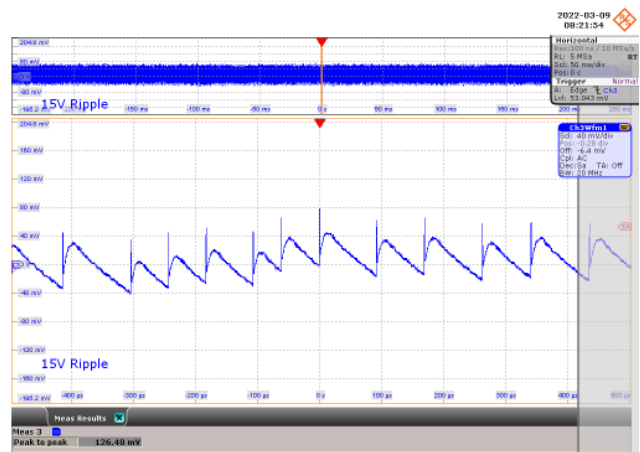

Figure 189 – 550 VDC Input.
 CH3: V_{OUT} , 40 mV / div., 50 ms / div.
 Zoom: 100 μ s / div.
 15 V Output Ripple = 126.48 mV.

10.5.2.5 10% Load Condition

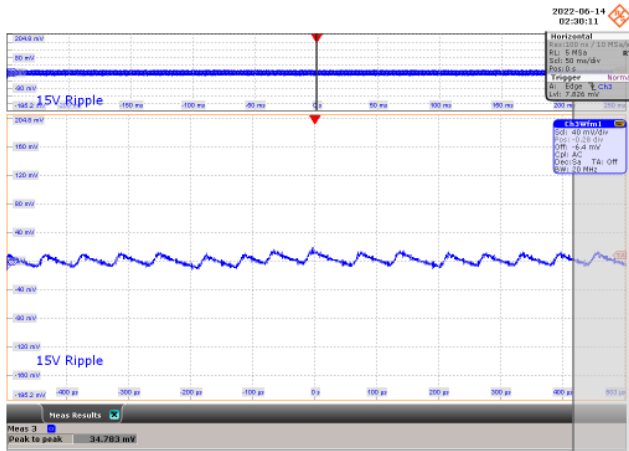

Figure 190 – 30 VDC Input.
 CH3: V_{OUT} , 40 mV / div., 50 ms / div.
 Zoom: 100 μ s / div.
 15 V Output Ripple = 34.783 mV.

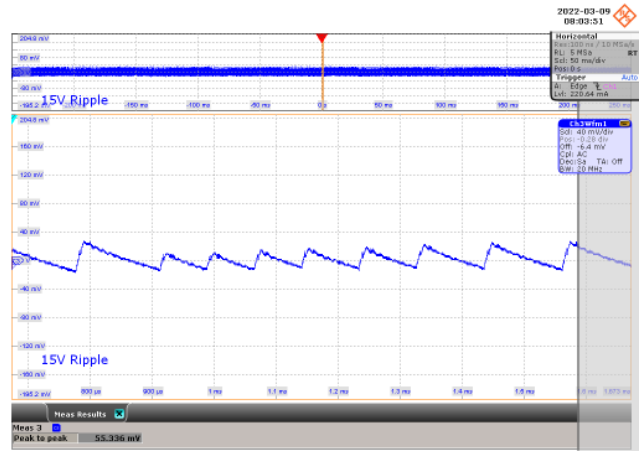

Figure 191 – 60 VDC Input.
 CH3: V_{OUT} , 40 mV / div., 50 ms / div.
 Zoom: 100 μ s / div.
 15 V Output Ripple = 55.336 mV.

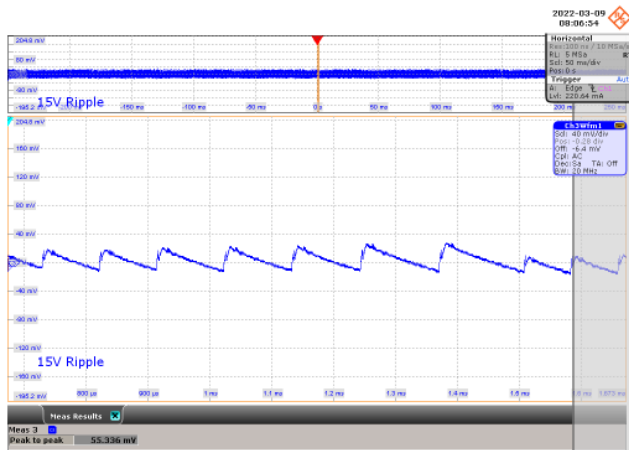

Figure 192 – 100 VDC Input.
 CH3: V_{OUT} , 40 mV / div., 50 ms / div.
 Zoom: 100 μ s / div.
 15 V Output Ripple = 55.336 mV.

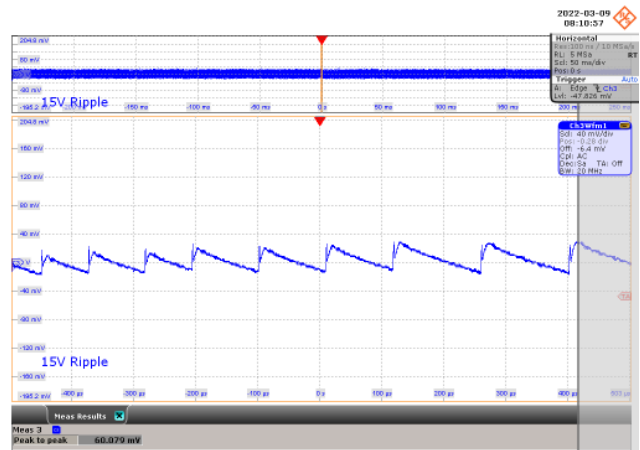

Figure 193 – 200 VDC Input.
 CH3: V_{OUT} , 40 mV / div., 50 ms / div.
 Zoom: 100 μ s / div.
 15 V Output Ripple = 60.079 mV.

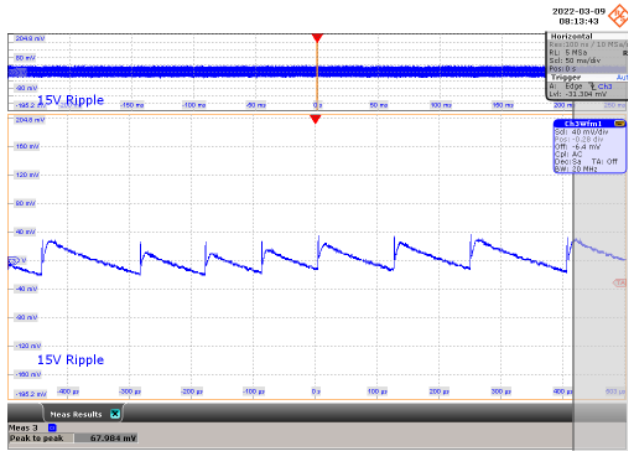

Figure 194 – 300 VDC Input.
 CH3: V_{OUT} , 40 mV / div., 50 ms / div.
 Zoom: 100 μ s / div.
 15 V Output Ripple = 67.984 mV.

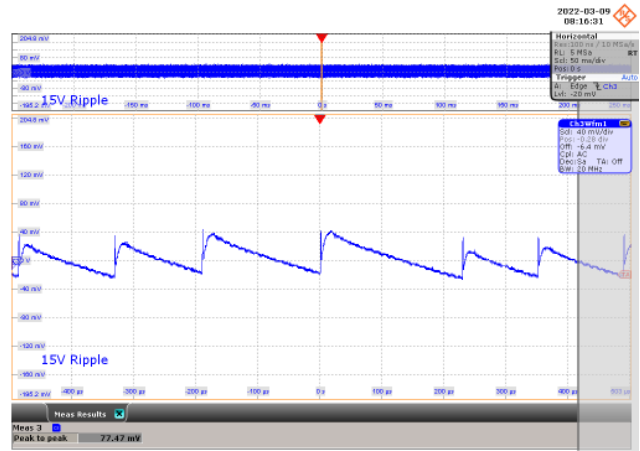

Figure 195 – 400 VDC Input.
 CH3: V_{OUT} , 40 mV / div., 50 ms / div.
 Zoom: 100 μ s / div.
 15 V Output Ripple = 77.47 mV.

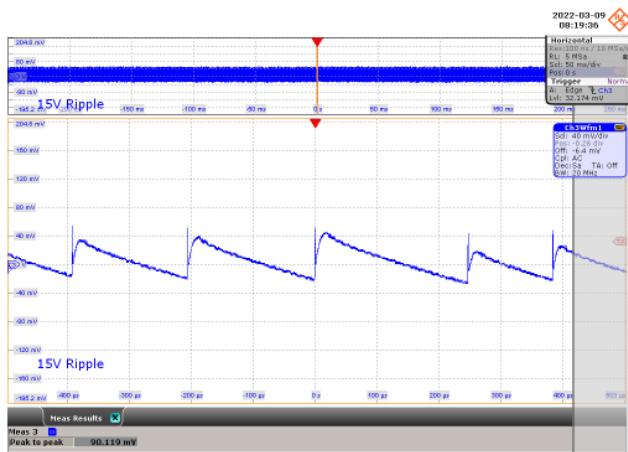

Figure 196 – 500 VDC Input.
 CH3: V_{OUT} , 40 mV / div., 50 ms / div.
 Zoom: 100 μ s / div.
 15 V Output Ripple = 90.119 mV.

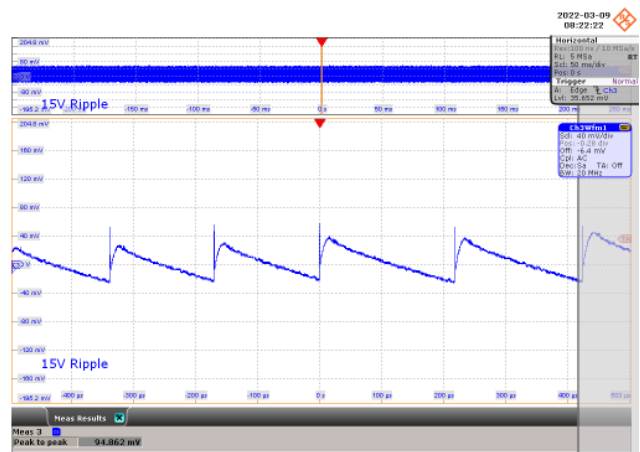

Figure 197 – 550 VDC Input.
 CH3: V_{OUT} , 40 mV / div., 50 ms / div.
 Zoom: 100 μ s / div.
 15 V Output Ripple = 94.862 mV.

10.5.3 15 V Output Ripple Voltage Graph from 0% - 100% with 10% Increment

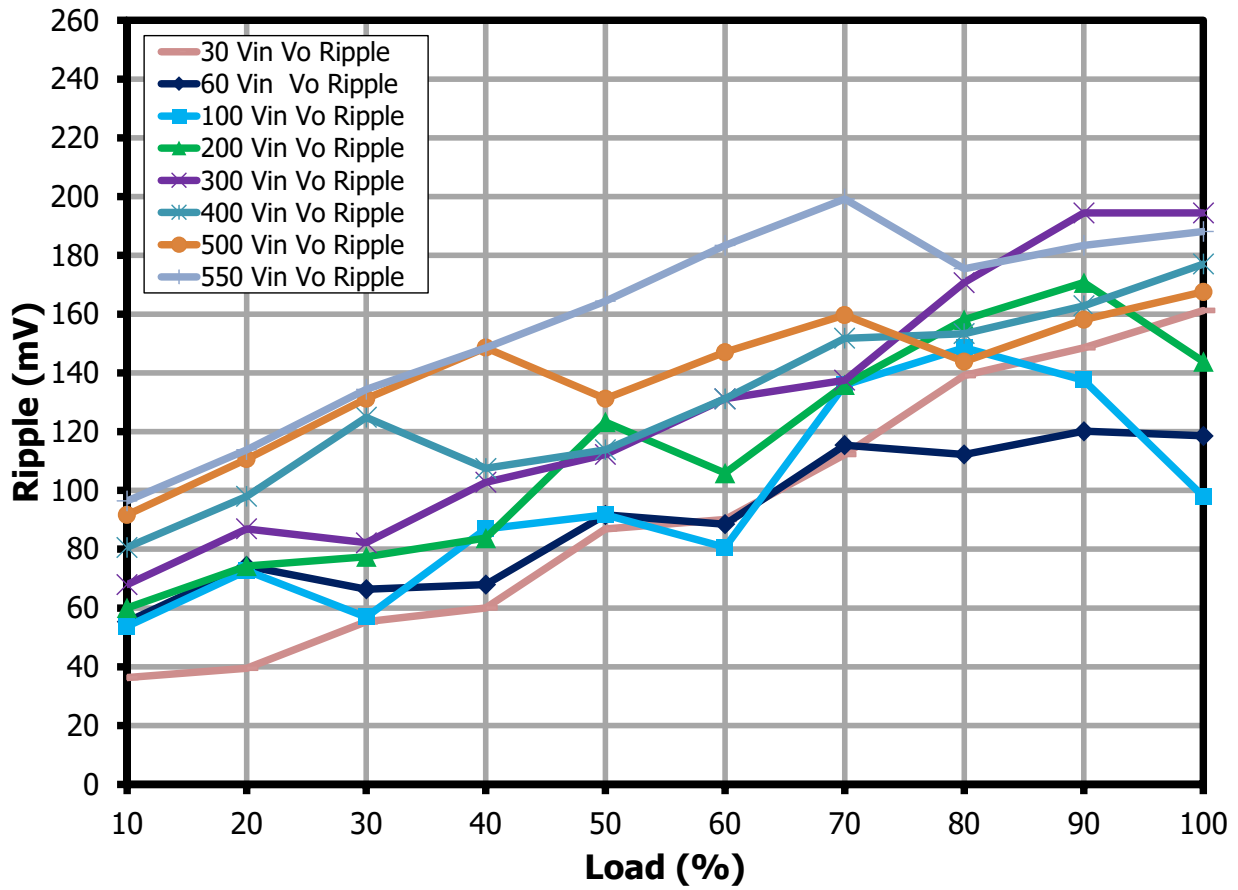

Figure 198 – 15 V Voltage Ripple (Measured at PCB End at Room Temperature).

11 Thermal Performance

11.1 Thermal Performance at Room Temperature

Soak time = 60 minutes, full load.

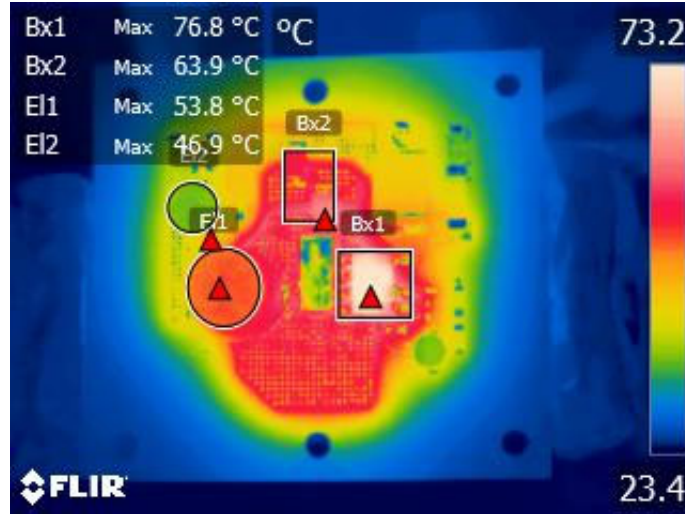

Figure 199 – Thermal Performance at 30 VDC Input.

Component	Temperature (°C)
LNK3209GQ (U1)	76.8
Freewheel Diode (D1/D2)	63.9
Output Inductor (L1)	53.8
Output Capacitor (C4)	46.9
Ambient	23.4

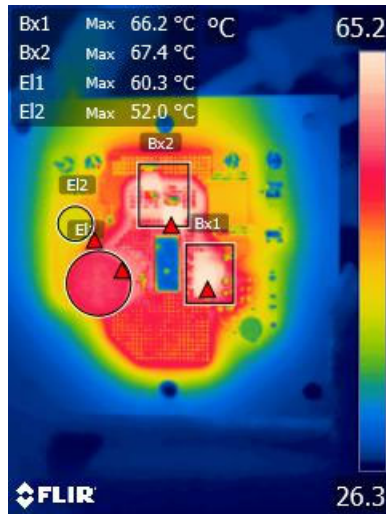

Figure 200 – Thermal Performance at 60 VDC Input.

Component	Temperature (°C)
LNK3209GQ (U1)	66.2
Freewheel Diode (D1/D2)	67.4
Output Inductor (L1)	60.3
Output Capacitor (C4)	52.0
Ambient	26.3

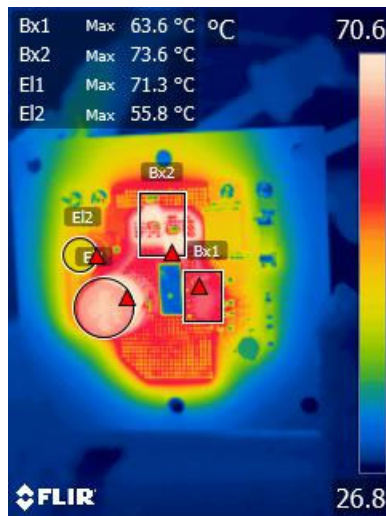

Figure 201 – Thermal Performance at 200 VDC Input.

Component	Temperature (°C)
LNK3209GQ (U1)	63.6
Freewheel Diode (D1/D2)	73.6
Output Inductor (L1)	71.3
Output Capacitor (C4)	55.8
Ambient	26.8

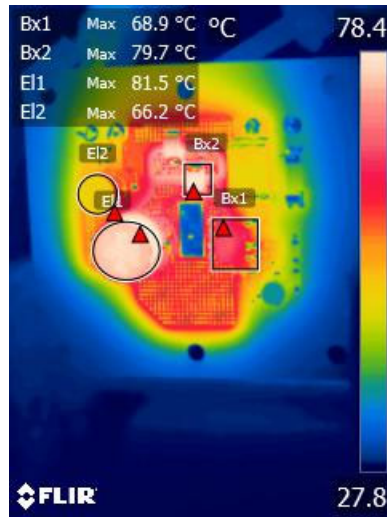

Figure 202 – Thermal Performance at 400 VDC Input.

Component	Temperature (°C)
LNK3209GQ (U1)	68.9
Freewheel Diode (D1/D2)	79.7
Output Inductor (L1)	81.5
Output Capacitor (C4)	66.2
Ambient	27.8

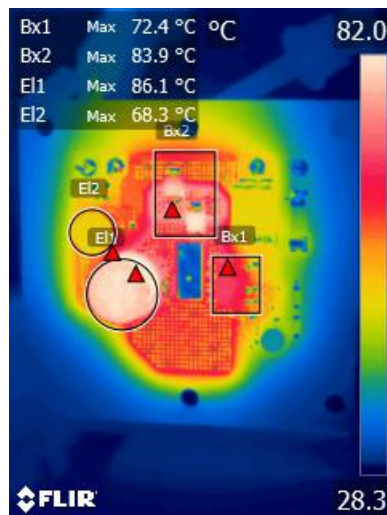

Figure 203 – Thermal Performance at 500 VDC Input.

Component	Temperature (°C)
LNK3209GQ (U1)	72.4
Freewheel Diode (D1/D2)	83.9
Output Inductor (L1)	86.1
Output Capacitor (C4)	68.3
Ambient	28.3

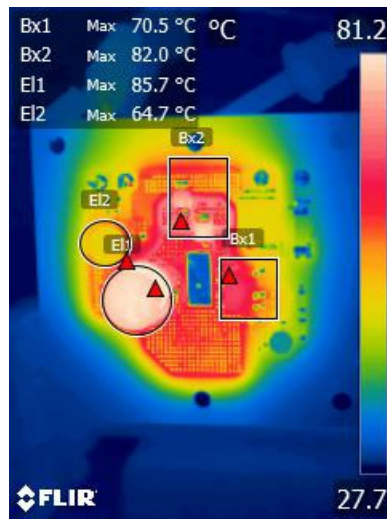

Figure 204 – Thermal Performance at 550 VDC Input.

Component	Temperature (°C)
LNK3209GQ (U1)	70.5
Freewheel Diode (D1/D2)	82.0
Output Inductor (L1)	85.7
Output Capacitor (C4)	64.7
Ambient	27.7

11.2 Thermal Performance at 85 °C

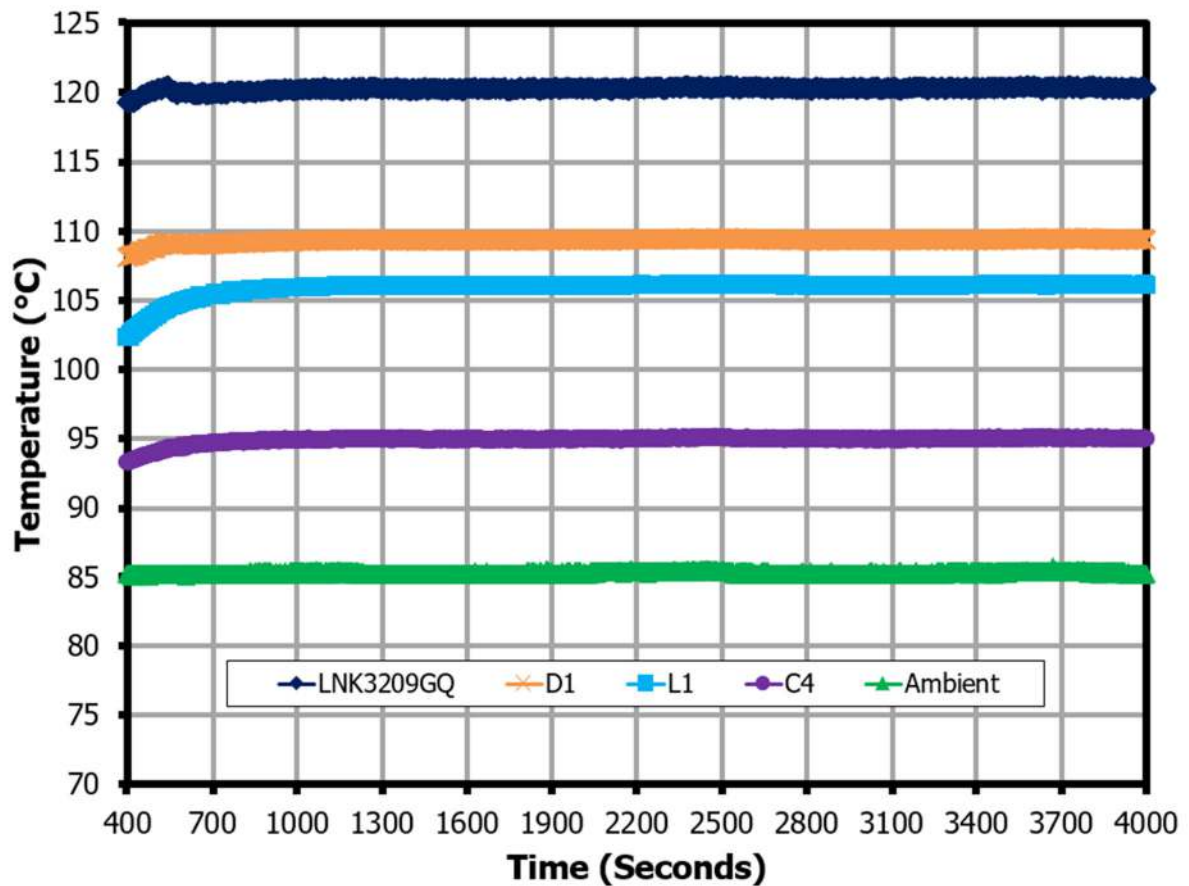

Figure 205 – 30 VDC Input with 570 mA Load Thermal Performance at 85 °C.

Component	Temperature (°C)
LNK3209GQ (U1)	120.3
Freewheel Diode (D1)	109.4
Output Inductor (L1)	106.1
Output Capacitor (C4)	95
Ambient	85.3

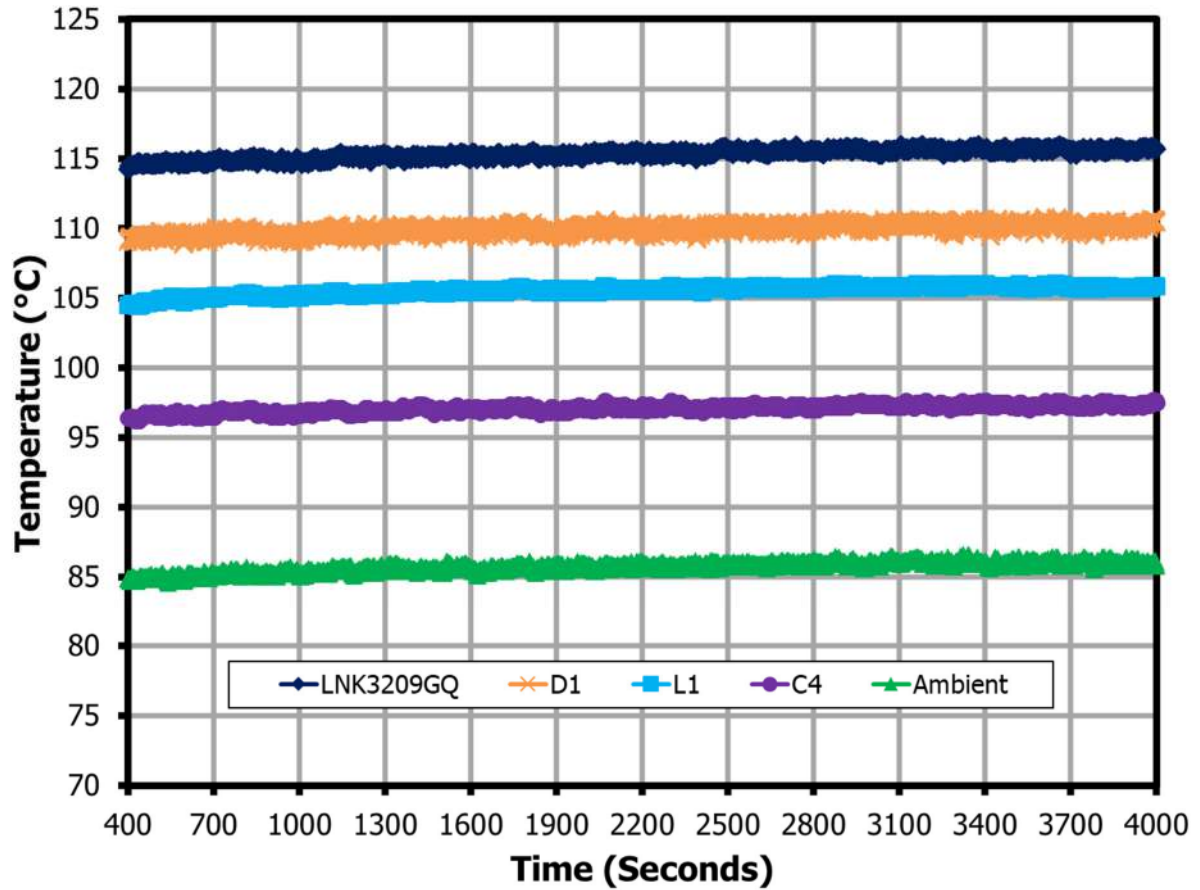

Figure 206 – 60 VDC Input with 650 mA Load Thermal Performance at 85 °C.

Component	Temperature (°C)
LNK3209GQ (U1)	116.2
Freewheel Diode (D1)	110.8
Output Inductor (L1)	106.1
Output Capacitor (C4)	97.6
Ambient	86.4

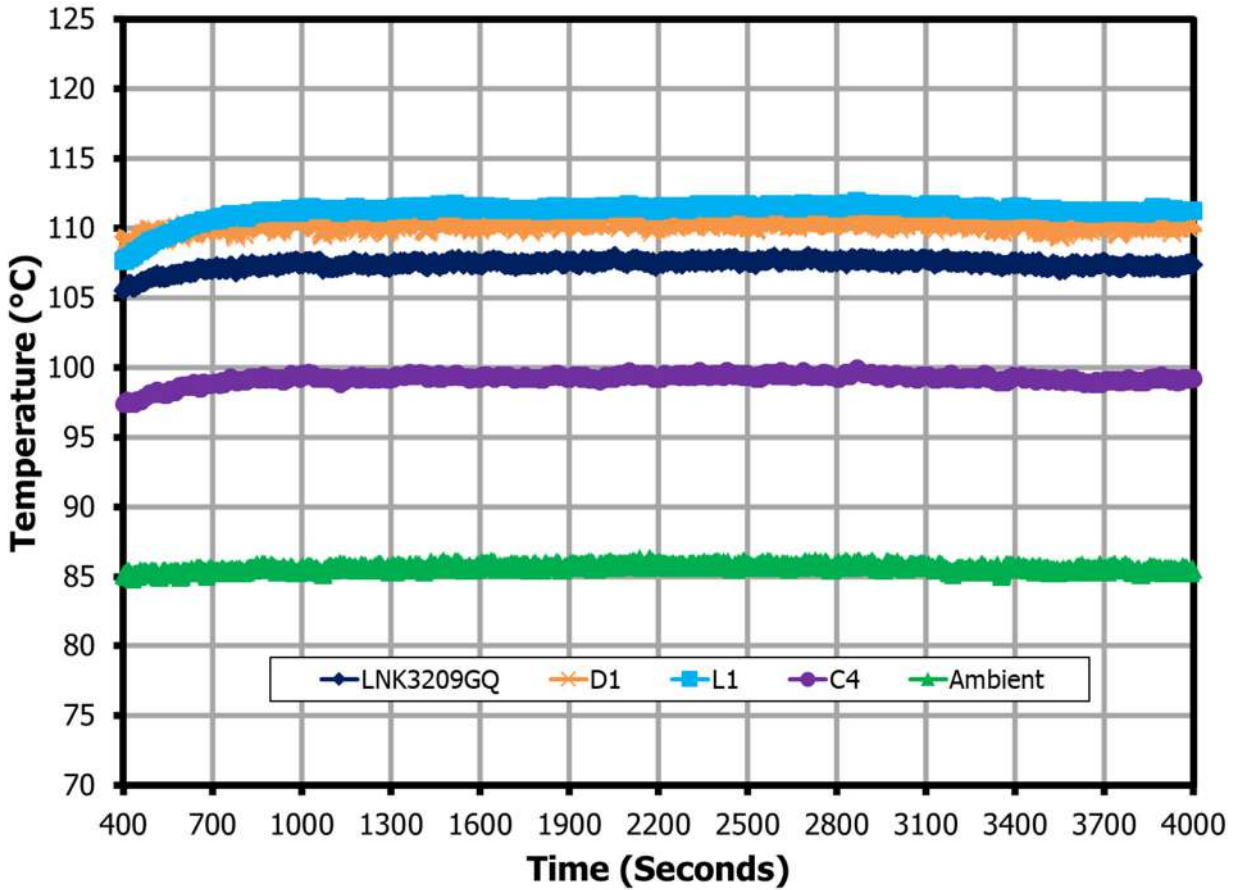

Figure 207 – 200 VDC Input with 650 mA Load Thermal Performance at 85 °C.

Component	Temperature (°C)
LNK3209GQ (U1)	107.4
Freewheel Diode (D1)	110.2
Output Inductor (L1)	11.2
Output Capacitor (C4)	99
Ambient	85.6

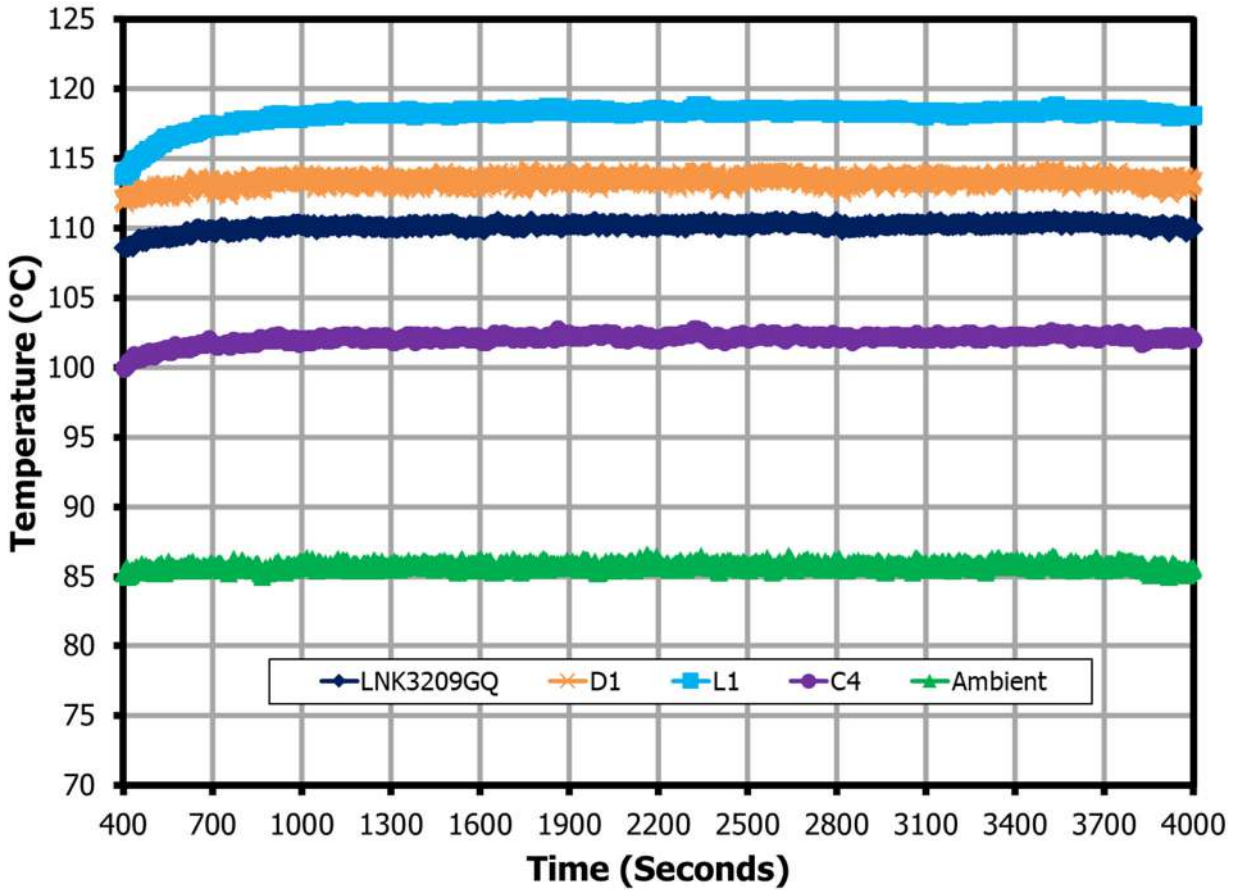

Figure 208 – 400 VDC Input with 650 mA Load Thermal Performance at 85 °C.

Component	Temperature (°C)
LNK3209GQ (U1)	110.2
Freewheel Diode (D1)	113.8
Output Inductor (L1)	118.1
Output Capacitor (C4)	102
Ambient	85.5

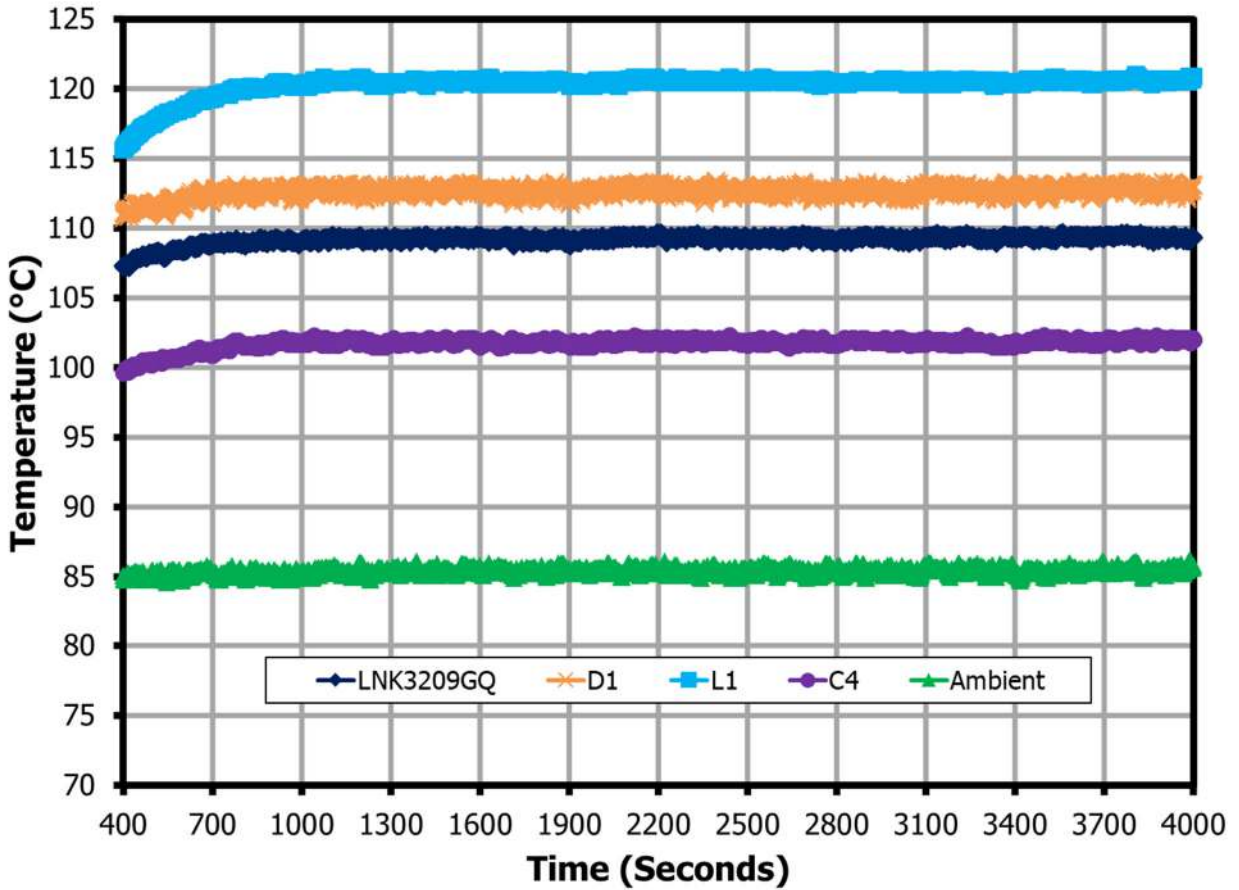

Figure 209 – 550 VDC Input with 650 mA Load Thermal Performance at 85 °C.

Component	Temperature (°C)
LNK3209GQ (U1)	109.4
Freewheel Diode (D1)	113.2
Output Inductor (L1)	120.6
Output Capacitor (C4)	101.8
Ambient	85.7

11.3 Thermal Performance at 105 °C with Thermal Pad to Enclosure

To simulate placing a thermal pad between the board and the enclosure the following test was performed. This is specifically applicable to automotive subsystems like the traction inverter where the enclosure surface temperature is significantly lower (~65 °C) than the internal ambient air temperature inside the enclosure (~105 °C)

11.3.1 RD-707Q Assembly with Thermal Pad

11.3.1.1 Material List

Item	Qty	Description
1	72 mm x 67 mm	Aluminum Sheet Thickness 1.5 mm.
2	6 pcs	1.4 mm Spacer (MFG P/N: MSW1020A).
3	7 2 mm x 67 mm	Thermal Pad (MFG P/N: TG-A126X-150-150-1.5).
4	6 sets	Screws, Nuts, Washer.

Cut aluminum sheet to 72 mm x 67 mm and drill holes based on the outer holes of RD-707Q PCB.



Figure 210 – Cut Aluminum Sheet with Hole.

Cut thermal pad to 72 mm x 67 mm.



Figure 211 – Cut Thermal Pad.

Assemble aluminum sheet, thermal pad, and spacer as shown.



Figure 212 – Assembled Aluminum Sheet, Thermal Pad, and spacer.

Assemble RD-707Q to the thermal pad heat sink with screws, nuts, and washer.

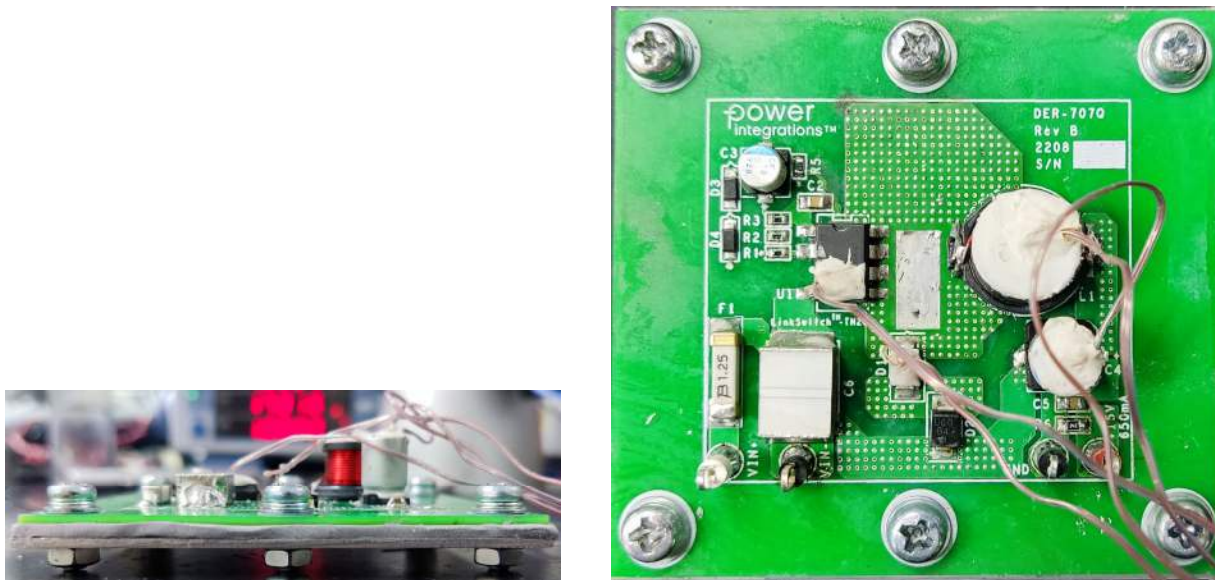

Figure 213 – RD-707Q Assembled to Simulate Thermal Pad to Enclosure.

11.3.2 RD-707Q Thermal Data at 105 °C

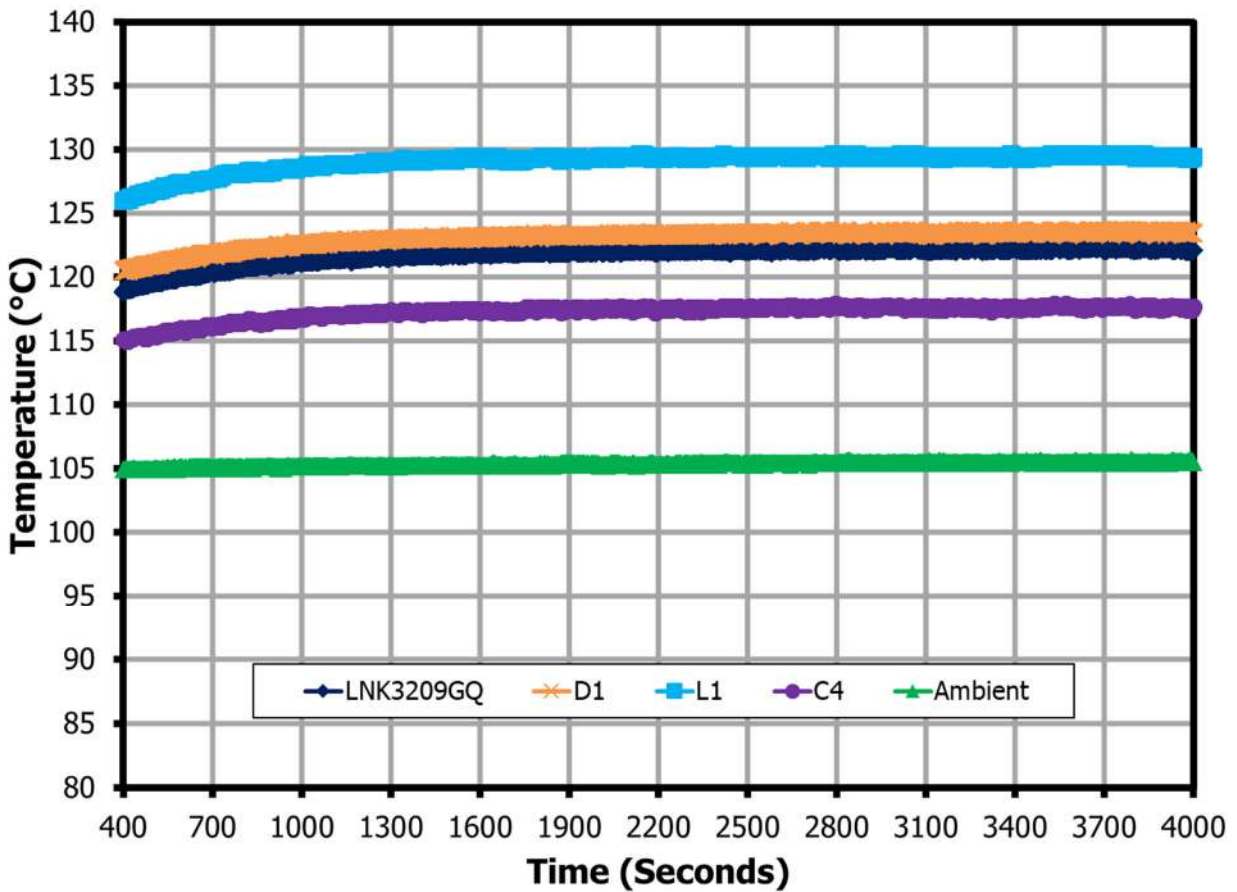

Figure 214 – 200 VDC Input with 650 mA Load Thermal Performance at 105 °C.

Component	Temperature (°C)
LNK3209GQ (U1)	122.1
Freewheel Diode (D1)	123.4
Output Inductor (L1)	129.4
Output Capacitor (C4)	117.7
Ambient	105.5

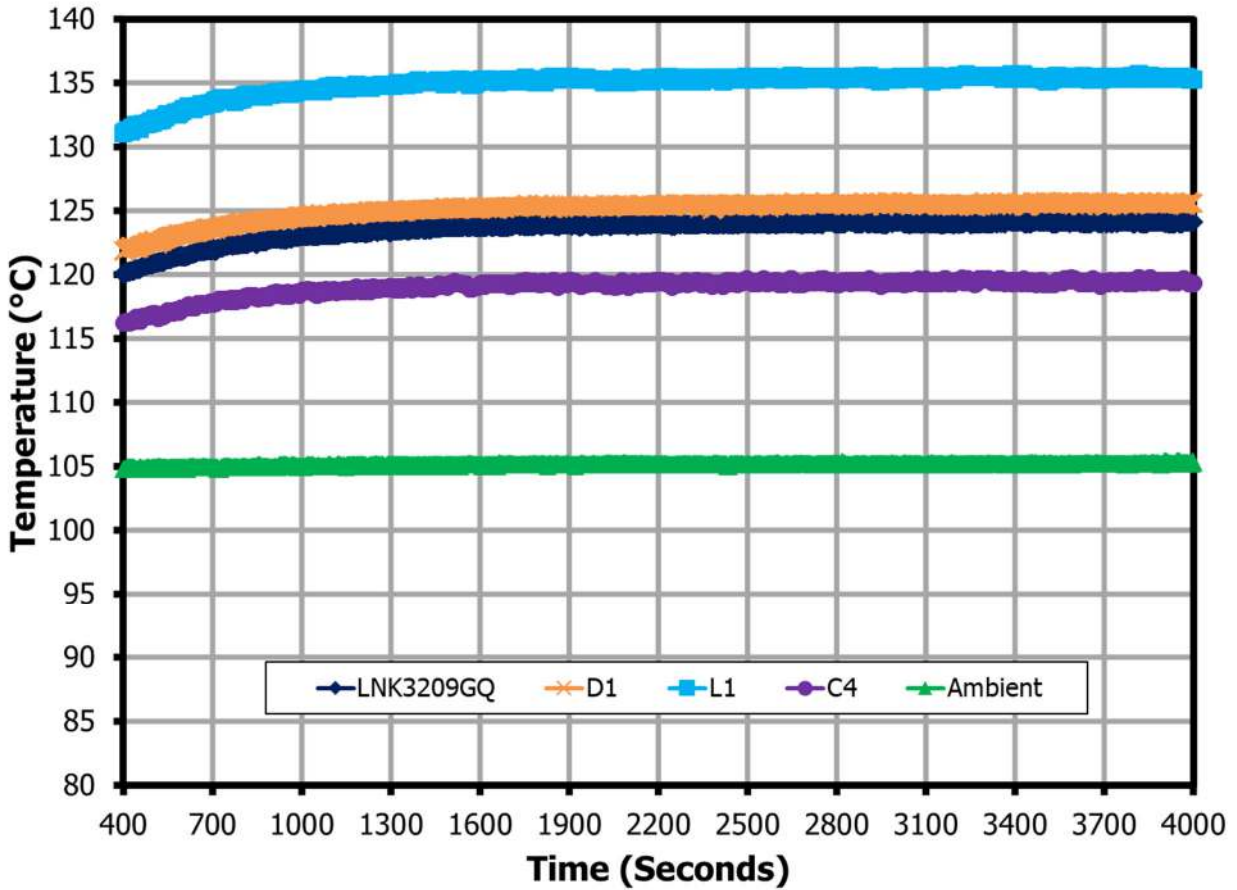

Figure 215 – 400 VDC Input with 650 mA Load Thermal Performance at 105 °C.

Component	Temperature (°C)
LNK3209GQ (U1)	124.1
Freewheel Diode (D1)	125.6
Output Inductor (L1)	135.3
Output Capacitor (C4)	119.4
Ambient	105.3

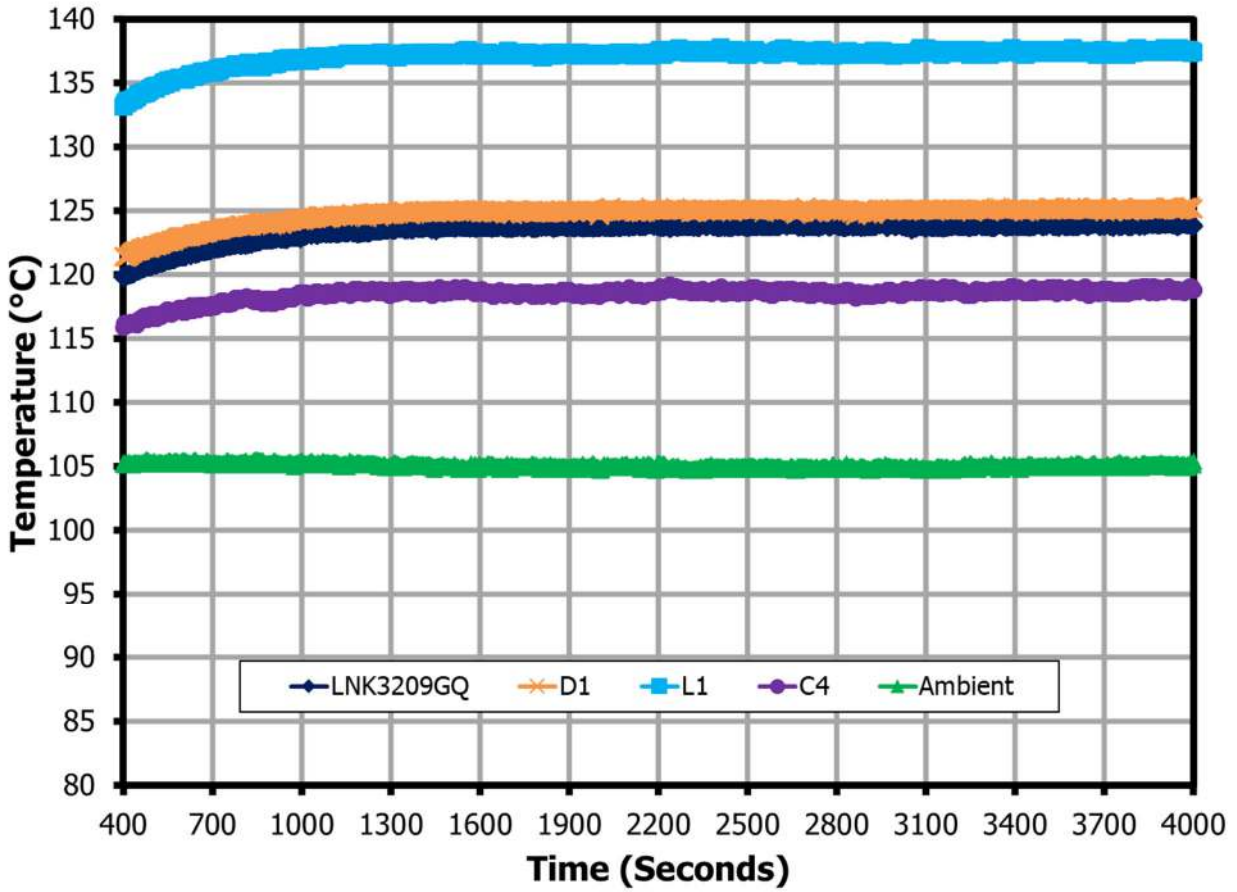

Figure 216 – 550 VDC Input with 650 mA Load Thermal Performance at 105 °C.

Component	Temperature (°C)
LNK3209GQ (U1)	123.8
Freewheel Diode (D1)	125.2
Output Inductor (L1)	137.4
Output Capacitor (C4)	118.8
Ambient	105.4

12 Revision History

Date	Author	Revision	Description and Changes	Reviewed
10-Aug-22	RPA / JKB / MMT	1.5	Converted to a RDK	Apps & Mktg



For the latest updates, visit our website: www.power.com

Reference Designs are technical proposals concerning how to use Power Integrations' gate drivers in particular applications and/or with certain power modules. These proposals are "as is" and are not subject to any qualification process. The suitability, implementation and qualification are the sole responsibility of the end user. The statements, technical information and recommendations contained herein are believed to be accurate as of the date hereof. All parameters, numbers, values and other technical data included in the technical information were calculated and determined to our best knowledge in accordance with the relevant technical norms (if any). They may base on assumptions or operational conditions that do not necessarily apply in general. We exclude any representation or warranty, express or implied, in relation to the accuracy or completeness of the statements, technical information and recommendations contained herein. No responsibility is accepted for the accuracy or sufficiency of any of the statements, technical information, recommendations or opinions communicated and any liability for any direct, indirect or consequential loss or damage suffered by any person arising therefrom is expressly disclaimed.

Power Integrations reserves the right to make changes to its products at any time to improve reliability or manufacturability. Power Integrations does not assume any liability arising from the use of any device or circuit described herein. POWER INTEGRATIONS MAKES NO WARRANTY HEREIN AND SPECIFICALLY DISCLAIMS ALL WARRANTIES INCLUDING, WITHOUT LIMITATION, THE IMPLIED WARRANTIES OF MERCHANTABILITY, FITNESS FOR A PARTICULAR PURPOSE, AND NON-INFRINGEMENT OF THIRD PARTY RIGHTS.

Patent Information

The products and applications illustrated herein (including transformer construction and circuits' external to the products) may be covered by one or more U.S. and foreign patents, or potentially by pending U.S. and foreign patent applications assigned to Power Integrations. A complete list of Power Integrations' patents may be found at www.power.com. Power Integrations grants its customers a license under certain patent rights as set forth at <http://www.power.com/ip.htm>.

Power Integrations, the Power Integrations logo, CAPZero, ChiPhy, CHY, DPA-Switch, EcoSmart, E-Shield, eSIP, eSOP, HiperPLC, HiperPFS, HiperTFS, InnoSwitch, Innovation in Power Conversion, InSOP, LinkSwitch, LinkZero, LYTSwitch, SENZero, TinySwitch, TOPSwitch, PI, PI Expert, SCALE, SCALE-1, SCALE-2, SCALE-3 and SCALE-iDriver, are trademarks of Power Integrations, Inc. Other trademarks are property of their respective companies. ©2019, Power Integrations, Inc.

Power Integrations Worldwide Sales Support Locations**WORLD HEADQUARTERS**

5245 Hellyer Avenue
San Jose, CA 95138, USA.
Main: +1-408-414-9200
Customer Service:
Worldwide: +1-65-635-64480
Americas: +1-408-414-9621
e-mail: usasales@power.com

CHINA (SHANGHAI)

Rm 2410, Charity Plaza, No. 88,
North Caoxi Road,
Shanghai, PRC 200030
Phone: +86-21-6354-6323
e-mail: chinasales@power.com

CHINA (SHENZHEN)

17/F, Hivac Building, No. 2, Keji
Nan 8th Road, Nanshan District,
Shenzhen, China, 518057
Phone: +86-755-8672-8689
e-mail: chinasales@power.com

GERMANY (AC-DC/LED Sales)

Einsteinring 24
85609 Dornach/Aschheim
Germany
Tel: +49-89-5527-39100
e-mail: eurosales@power.com

GERMANY (Gate Driver Sales)

HellwegForum 1
59469 Ense
Germany
Tel: +49-2938-64-39990
e-mail: igbt-driver.sales@power.com

INDIA

#1, 14th Main Road
Vasanthanagar
Bangalore-560052
India
Phone: +91-80-4113-8020
e-mail: indiasales@power.com

ITALY

Via Milanese 20, 3rd. Fl.
20099 Sesto San Giovanni (MI) Italy
Phone: +39-024-550-8701
e-mail: eurosales@power.com

JAPAN

Yusen Shin-Yokohama 1-chome Bldg.
1-7-9, Shin-Yokohama, Kohoku-ku
Yokohama-shi,
Kanagawa 222-0033 Japan
Phone: +81-45-471-1021
e-mail: japansales@power.com

KOREA

RM 602, 6FL
Korea City Air Terminal B/D,
159-6
Samsung-Dong, Kangnam-Gu,
Seoul, 135-728 Korea
Phone: +82-2-2016-6610
e-mail: koreasales@power.com

SINGAPORE

51 Newton Road,
#19-01/05 Goldhill Plaza
Singapore, 308900
Phone: +65-6358-2160
e-mail: singaporesales@power.com

TAIWAN

5F, No. 318, Nei Hu Rd.,
Sec. 1
Nei Hu District
Taipei 11493, Taiwan R.O.C.
Phone: +886-2-2659-4570
e-mail: taiwansales@power.com

UK

Building 5, Suite 21
The Westbrook Centre
Milton Road
Cambridge
CB4 1YG
Phone: +44 (0) 7823-557484
e-mail: eurosales@power.com

