

## HGTP14N44G3VL / HGT1S14N44G3VLS

### 300mJ, 440V, N-Channel Ignition IGBT

#### General Description

This N-Channel IGBT is a MOS gated, logic level device which is intended to be used as an ignition coil driver in automotive ignition circuits. Unique features include an active voltage clamp between the collector and the gate and ESD protection for the logic level gate. Some specifications are unique to this automotive application and are intended to assure device survival in this harsh environment.

Formerly Developmental Type 49238

#### Applications

- Automotive Ignition Coil Driver Circuits
- Coil-On Plug Applications

#### Features

- Logic Level Gate Drive
- Internal Voltage Clamp
- ESD Gate Protection
- Max  $T_J = 175^\circ\text{C}$
- SCIS Energy = 300mJ at  $T_J = 25^\circ\text{C}$

#### Package

JEDEC TO-263AB  
D<sup>2</sup>-Pak

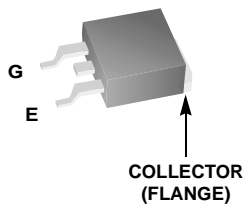

JEDEC TO-220AB

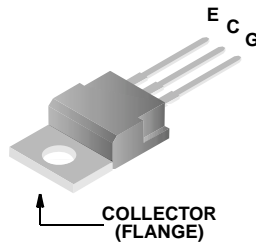

#### Symbol

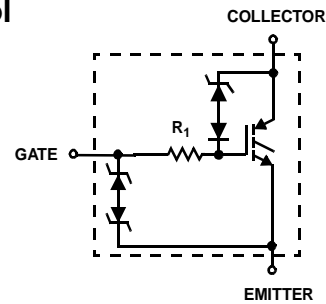

#### Device Maximum Ratings $T_A = 25^\circ\text{C}$ unless otherwise noted

Symbol	Parameter	Ratings	Units
$BV_{CES}$	Collector to Emitter Breakdown Voltage ( $I_C = 10\text{ mA}$ )	490	V
$E_{SCIS25}$	Drain to Source Avalanche Energy at $L = 2.3\text{mH}$ , $T_C = 25^\circ\text{C}$	300	mJ
$I_{C25}$	Collector Current Continuous, at $T_C = 25^\circ\text{C}$ , $V_{GE} = 4.5\text{V}$	27	A
$I_{C90}$	Collector Current Continuous, at $T_C = 90^\circ\text{C}$ , $V_{GE} = 4.5\text{V}$	21	A
$V_{GES}$	Gate to Emitter Voltage Continuous	$\pm 10$	V
$V_{GEM}$	Gate to Emitter Voltage Pulsed	$\pm 12$	V
$I_{CO}$	$L = 2.3\text{mH}$ , $T_C = 25^\circ\text{C}$	20	A
$I_{CO}$	$L = 2.3\text{mH}$ , $T_C = 150^\circ\text{C}$	15	A
$P_D$	Power Dissipation Total $T_C = 25^\circ\text{C}$	231	W
	Power Dissipation Derating $T_C > 25^\circ\text{C}$	1.54	W/ $^\circ\text{C}$
$T_J, T_{STG}$	Operating and Storage Junction Temperature Range	-40 to 175	$^\circ\text{C}$
$T_L$	Max Lead Temp for Soldering (Leads at 1.6mm from Case for 10s)	300	$^\circ\text{C}$
$T_{pkg}$	Max Lead Temp for Soldering (Package Body for 10s)	260	$^\circ\text{C}$
ESD	Electrostatic Discharge Voltage at 100pF, 1500 $\Omega$	6	KV

## Package Marking and Ordering Information

Device Marking	Device	Package	Reel Size	Tape Width	Quantity
14N44GV	HGT1S14N44G3VLT	TO-263AB	24mm	24mm	800 units
14N44GV	HGT1S14N44G3VLS	TO-263AB	Tube	N/A	50 units
14N44GV	HGTP14N44G3VL	TO-220AB	Tube	N/A	50 units

## Electrical Characteristics $T_A = 25^\circ\text{C}$ unless otherwise noted

Symbol	Parameter	Test Conditions	Min	Typ	Max	Units
--------	-----------	-----------------	-----	-----	-----	-------

### Off State Characteristics

$BV_{CES}$	Collector to Emitter Breakdown Voltage	$I_C = 2\text{mA}$ , $V_{GE} = 0$	$T_C = -40^\circ\text{C}$ to $175^\circ\text{C}$	400	-	480	V
$BV_{CER}$	Collector to Emitter Breakdown Voltage	$I_C = 10\text{mA}$ , $R_G = 1\text{K}\Omega$	$T_C = 150^\circ\text{C}$	390	-	470	V
$BV_{ECS}$	Emitter to Collector Breakdown Voltage	$I_C = 1\text{mA}$	$T_C = 25^\circ\text{C}$	24	-	-	V
$BV_{GES}$	Gate to Emitter Breakdown Voltage	$I_{GES} = \pm 1\text{mA}$		$\pm 14$	-	-	V
$I_{CES}$	Collector to Emitter Leakage Current	$V_{CE} = 300\text{V}$ ,	$T_C = 25^\circ\text{C}$	-	-	10	$\mu\text{A}$
			$T_C = 150^\circ\text{C}$	-	-	250	$\mu\text{A}$
$I_{GES}$	Gate to Emitter Leakage Current	$V_{GE} = \pm 10\text{V}$	$T_C = 25^\circ\text{C}$	-	-	$\pm 5$	$\mu\text{A}$
$R_1$	Series Gate Resistance			-	1000	-	$\Omega$

### On State Characteristics

$V_{CE(SAT)}$	Collector to Emitter Saturation Voltage	$I_C = 8\text{A}$ , $V_{GE} = 4.5\text{V}$	$T_C = 25^\circ\text{C}$	-	1.3	1.9	V
			$T_C = 150^\circ\text{C}$	-	1.4	2.2	V
$V_{GE(TH)}$	Gate to Emitter Threshold Voltage	$I_C = 1\text{mA}$ , $V_{CE} = V_{GE}$	$T_C = -40^\circ\text{C}$	-	-	2.5	V
			$T_C = 150^\circ\text{C}$	0.6	-	-	V

### Switching Characteristics

$t_{d(off)}$	Current Turn-Off Delay Time-Inductive Load	$I_C = 7.5\text{A}$ , $R_G = 1\text{K}\Omega$ , $L = 1.0\text{mH}$ , $V_{CL} = 300\text{V}$ , $V_{GE} = 5\text{V}$ , $T_C = 25^\circ\text{C}$ , See Fig. 12		3	-	18	$\mu\text{s}$
$t_f$	Current Turn-Off Fall Time-Inductive Load	$I_C = 7.5\text{A}$ , $R_G = 1\text{K}\Omega$ , $L = 1.0\text{mH}$ , $V_{CL} = 300\text{V}$ , $V_{GE} = 5\text{V}$ , $T_C = 25^\circ\text{C}$ , See Fig. 12		3	-	15	$\mu\text{s}$
SCIS	Self Clamped Inductive Switching	$L = 2.3\text{mH}$ , $V_{GE} = 5\text{V}$ , See Fig. 1 & 2	$T_C = 25^\circ\text{C}$	20	-	-	A
			$T_C = 150^\circ\text{C}$	15	-	-	A

### Thermal Characteristics

$R_{\theta JC}$	Thermal Resistance Junction to Case		-	-	0.70	$^\circ\text{C/W}$
-----------------	-------------------------------------	--	---	---	------	--------------------

Typical Performance Curves (Continued)

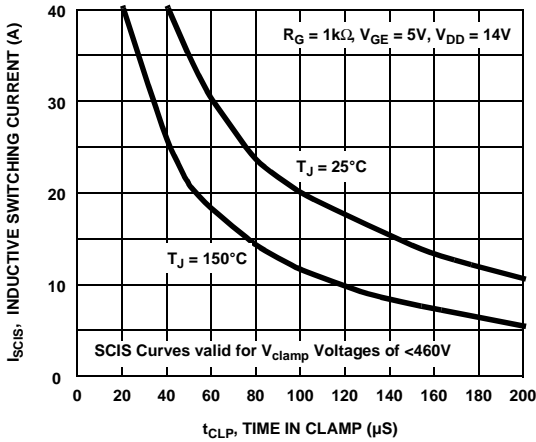

Figure 1. Self Clamped Inductive Switching Current vs Time

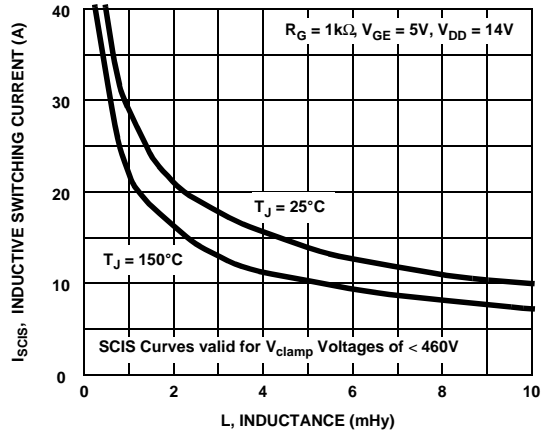

Figure 2. Self Clamped Inductive Switching Current vs Inductance

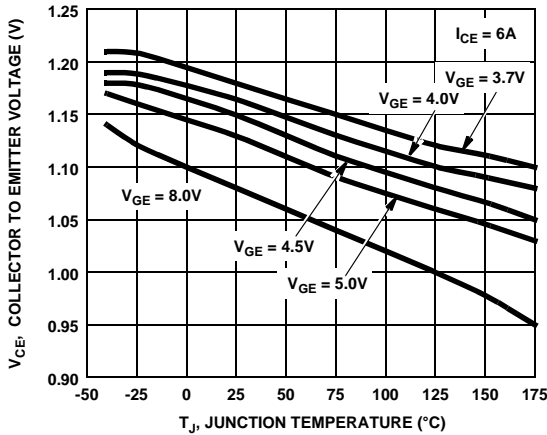

Figure 3. Collector to Emitter On-State Voltage vs Junction Temperature

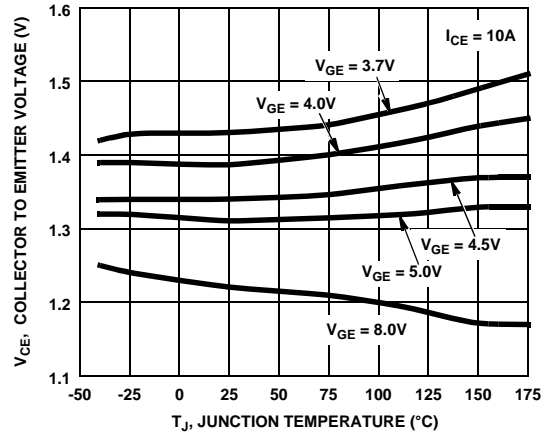

Figure 4. Collector to Emitter On-State Voltage vs Junction Temperature

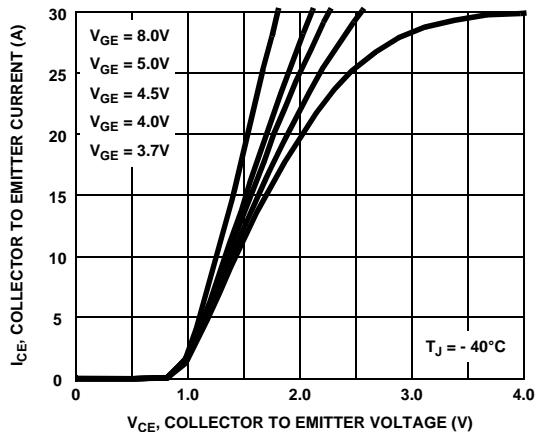

Figure 5. Collector to Emitter Current vs Collector to Emitter On-State Voltage

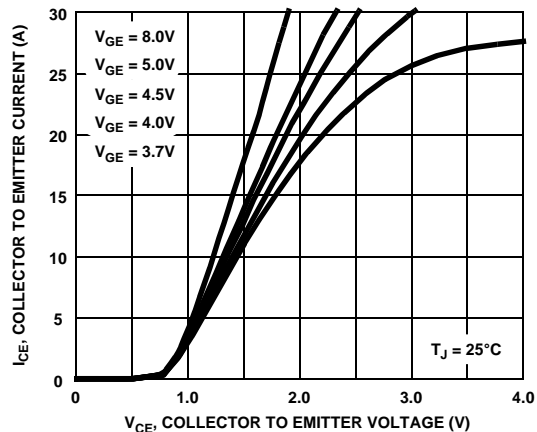

Figure 6. Collector to Emitter Current vs Collector to Emitter On-State Voltage

Typical Performance Curves (Continued)

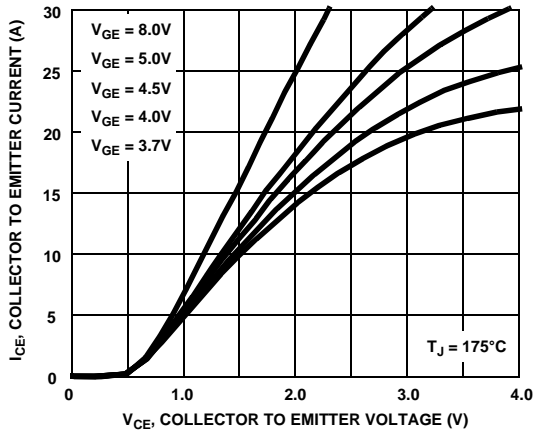

Figure 7. Collector to Emitter Current vs Collector to Emitter On-State Voltage

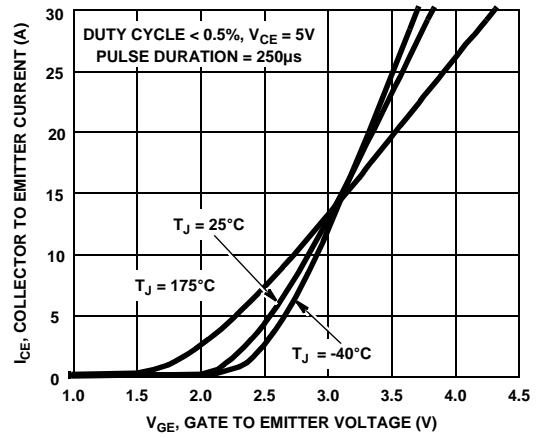

Figure 8. Transfer Characteristics

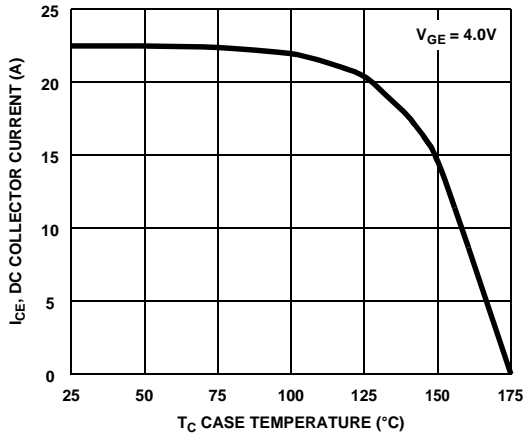

Figure 9. DC Collector Current vs Case Temperature

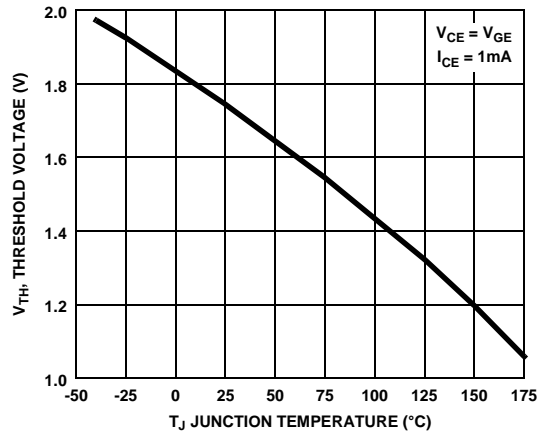

Figure 10. Threshold Voltage vs Junction Temperature

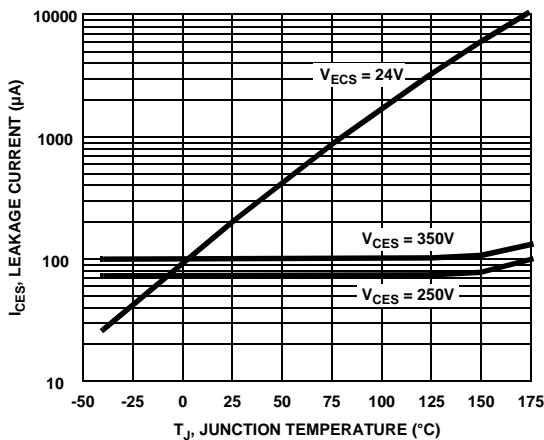

Figure 11. Leakage Current vs Junction Temperature

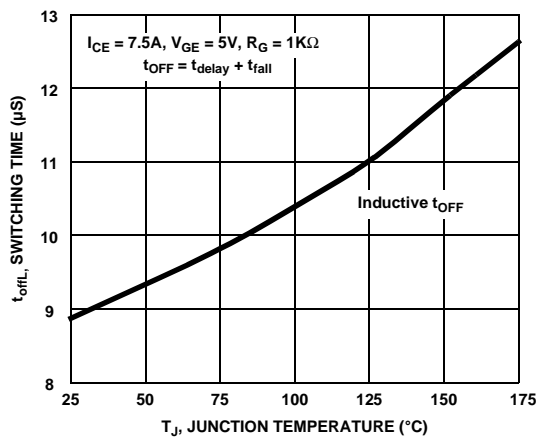

Figure 12. Switching Time vs Junction Temperature

Test Circuit and Waveforms

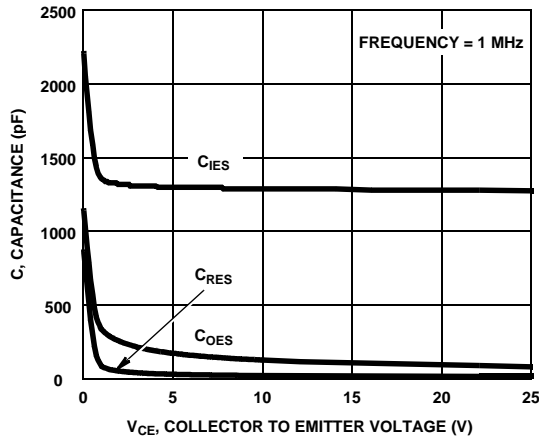

Figure 13. Capacitance vs Collector to Emitter Voltage

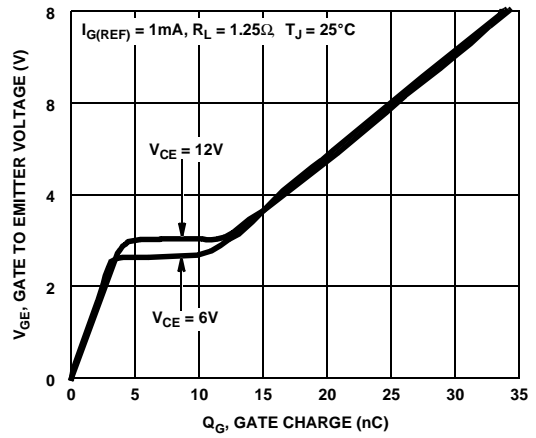

Figure 14. Gate Charge

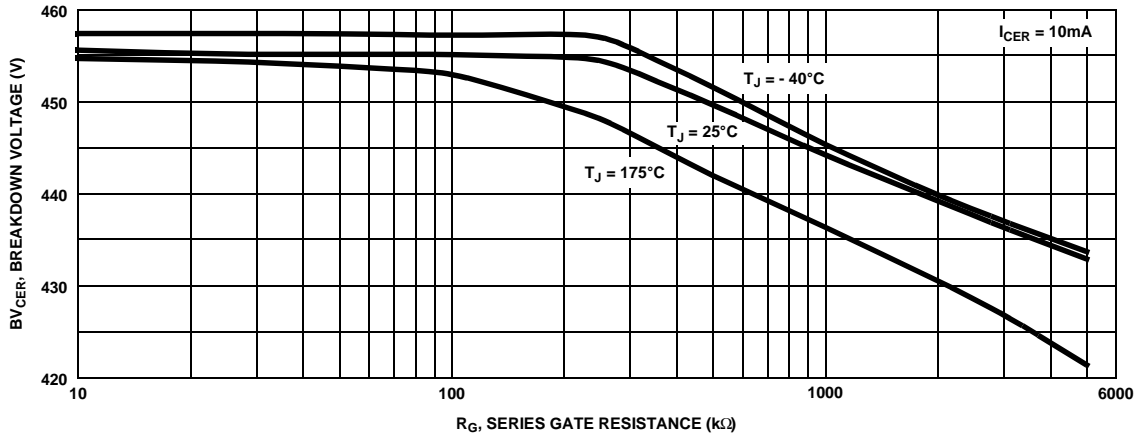

Figure 15. Breakdown Voltage vs Series Gate Resistance

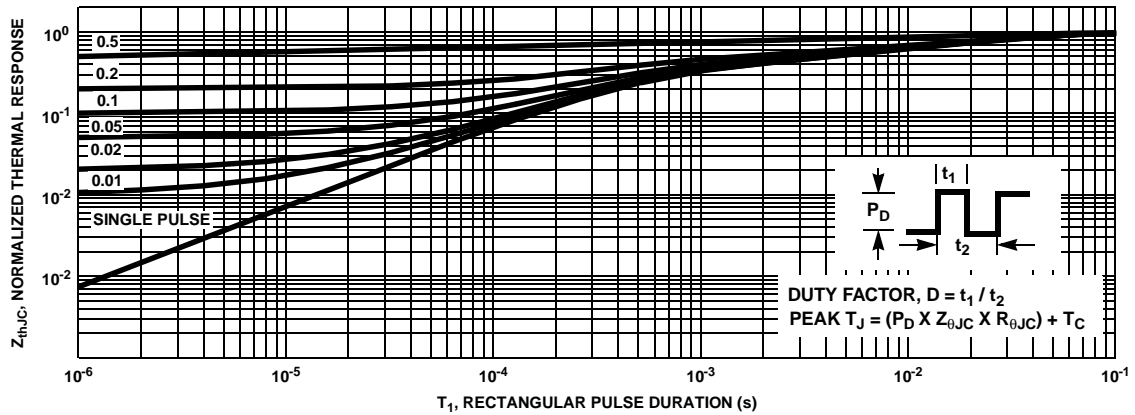

Figure 16. Normalized Transient Thermal Impedance

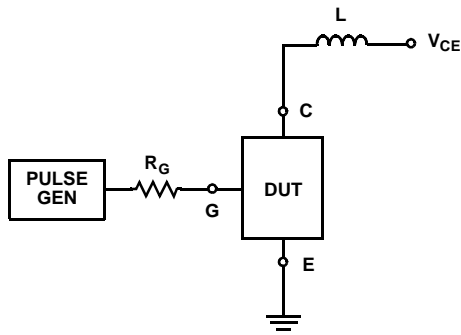

Figure 17. SCIS Test Circuit

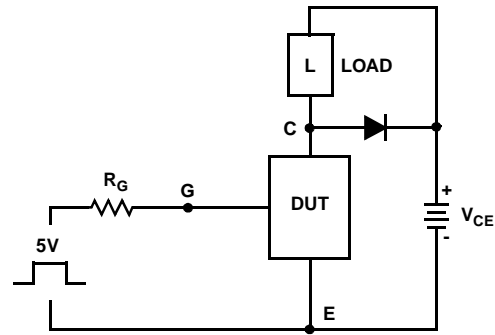

Figure 18.  $t_{OFF}$  Switching Test Circuit

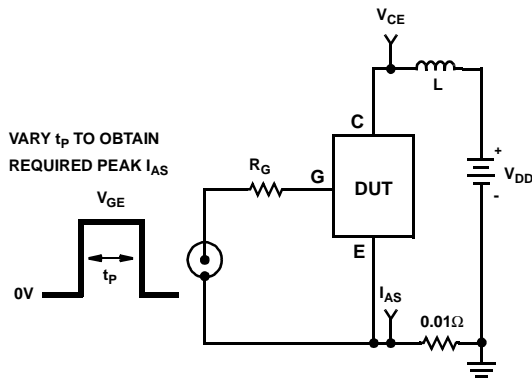

Figure 19. Unclamped Energy Test Circuit

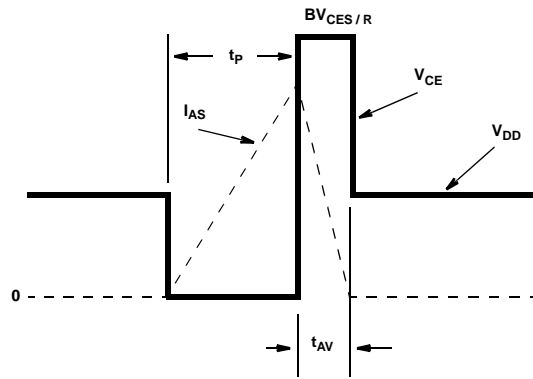

Figure 20. Unclamped Energy Waveforms

**SPICE Thermal Model**

REV April 2002

HGTP14N44G3VL / HGT1S14N44G3VLS

CTHERM1 th 6 3.2e-3  
 CTHERM2 6 5 1.7e-2  
 CTHERM3 5 4 2.6e-2  
 CTHERM4 4 3 4.8e-1  
 CTHERM5 3 2 1.8e-1  
 CTHERM6 2 tl 7.2e-1

RTHERM1 th 6 6.8e-2  
 RTHERM2 6 5 1.3e-1  
 RTHERM3 5 4 1.0e-1  
 RTHERM4 4 3 6.0e-2  
 RTHERM5 3 2 1.4e-1  
 RTHERM6 2 tl 3.6e-2

**SABER Thermal Model**

SABER thermal model  
 HGTP14N44G3VL / HGT1S14N44G3VLS  
 template thermal\_model th tl  
 thermal\_c th, tl

```
{
ctherm.ctherm1 th 6 = 3.2e-3
ctherm.ctherm2 6 5 = 1.7e-2
ctherm.ctherm3 5 4 = 2.6e-2
ctherm.ctherm4 4 3 = 4.8e-1
ctherm.ctherm5 3 2 = 1.8e-1
ctherm.ctherm6 2 tl = 7.2e-2
```

```
rtherm.rtherm1 th 6 = 6.8e-2
rtherm.rtherm2 6 5 = 1.3e-1
rtherm.rtherm3 5 4 = 1.0e-1
rtherm.rtherm4 4 3 = 6.0e-2
rtherm.rtherm5 3 2 = 1.4e-1
rtherm.rtherm6 2 tl = 3.6e-2
}
```

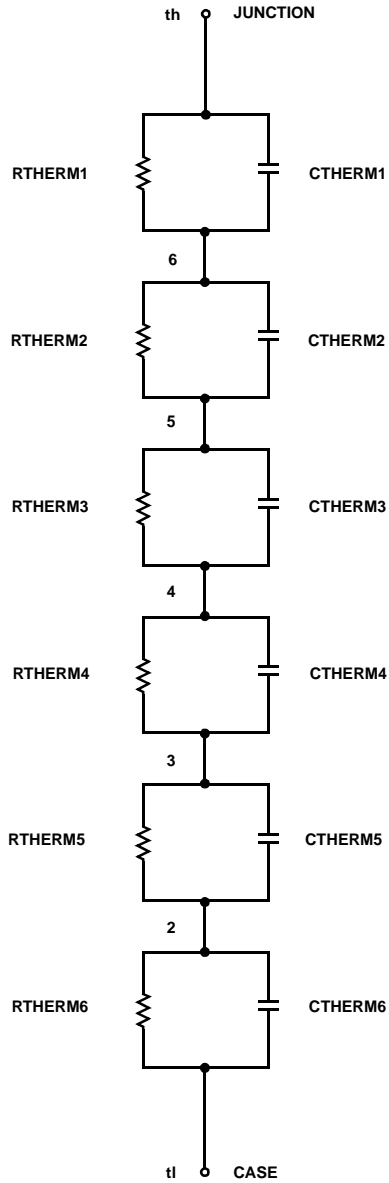

## TRADEMARKS

The following are registered and unregistered trademarks Fairchild Semiconductor owns or is authorized to use and is not intended to be an exhaustive list of all such trademarks.

ACE <sub>x</sub> ™	FAST®	MICROWIRE™	SILENT SWITCHER®	UHC™
Bottomless™	FAST <sub>r</sub> ™	OPTOLOGIC®	SMART START™	UltraFET®
CoolFET™	FRFET™	OPTOPLANAR™	SPM™	VCX™
CROSSVOLT™	GlobalOptoisolator™	PACMAN™	STAR*POWER™	
DenseTrench™	GTO™	POP™	Stealth™	
DOME™	HiSeC™	Power247™	SuperSOT™-3	
EcoSPARK™	I <sup>2</sup> C™	PowerTrench®	SuperSOT™-6	
E <sup>2</sup> CMOS™	ISOPLANAR™	QFET™	SuperSOT™-8	
EnSigna™	LittleFET™	QS™	SyncFET™	
FACT™	MicroFET™	QT Optoelectronics™	TinyLogic™	
FACT Quiet Series™	MicroPak™	Quiet Series™	TruTranslation™	

STAR\*POWER is used under license

## DISCLAIMER

FAIRCHILD SEMICONDUCTOR RESERVES THE RIGHT TO MAKE CHANGES WITHOUT FURTHER NOTICE TO ANY PRODUCTS HEREIN TO IMPROVE RELIABILITY, FUNCTION OR DESIGN. FAIRCHILD DOES NOT ASSUME ANY LIABILITY ARISING OUT OF THE APPLICATION OR USE OF ANY PRODUCT OR CIRCUIT DESCRIBED HEREIN; NEITHER DOES IT CONVEY ANY LICENSE UNDER ITS PATENT RIGHTS, NOR THE RIGHTS OF OTHERS.

## LIFE SUPPORT POLICY

FAIRCHILD'S PRODUCTS ARE NOT AUTHORIZED FOR USE AS CRITICAL COMPONENTS IN LIFE SUPPORT DEVICES OR SYSTEMS WITHOUT THE EXPRESS WRITTEN APPROVAL OF FAIRCHILD SEMICONDUCTOR CORPORATION. As used herein:

1. Life support devices or systems are devices or systems which, (a) are intended for surgical implant into the body, or (b) support or sustain life, or (c) whose failure to perform when properly used in accordance with instructions for use provided in the labeling, can be reasonably expected to result in significant injury to the user.
2. A critical component is any component of a life support device or system whose failure to perform can be reasonably expected to cause the failure of the life support device or system, or to affect its safety or effectiveness.

## PRODUCT STATUS DEFINITIONS

### Definition of Terms

Datasheet Identification	Product Status	Definition
Advance Information	Formative or In Design	This datasheet contains the design specifications for product development. Specifications may change in any manner without notice.
Preliminary	First Production	This datasheet contains preliminary data, and supplementary data will be published at a later date. Fairchild Semiconductor reserves the right to make changes at any time without notice in order to improve design.
No Identification Needed	Full Production	This datasheet contains final specifications. Fairchild Semiconductor reserves the right to make changes at any time without notice in order to improve design.
Obsolete	Not In Production	This datasheet contains specifications on a product that has been discontinued by Fairchild semiconductor. The datasheet is printed for reference information only.



Fairchild Semiconductor

SEARCH | [Parametric](#) | [Cross Reference](#)

[Product Folders and](#)  [Applies](#)

[find products](#)

[Home >>](#) [Find products >>](#)

[Products groups](#)

[Analog and Mixed](#)

[Signal](#)

[Discrete](#)

[Interface](#)

[Logic](#)

[Microcontrollers](#)

[Non-Volatile](#)

[Memory](#)

[Optoelectronics](#)

[Markets and](#)

[applications](#)

[New products](#)

[Product selection and](#)

[parametric search](#)

[Cross-reference](#)

[search](#)

HGTP14N44G3VL

21A, 440V N-Channel Logic Level , Voltage Clamped, Avalanche Energy Rated, ESD Protected Ignition IGBT, TO-220 Package

Contents

[General description](#) | [Features](#) | [Applications](#) | [Product status/pricing/packaging](#)

General description

This N-Channel IGBT is a MOS gated, logic level device which is intended to be used as an ignition coil driver in automotive ignition circuits. Unique features include an active voltage clamp between the collector and the gate and ESD protection for the logic level gate. Some specifications are unique to this automotive application and are intended to assure device survival in this harsh environment.

Formerly Developmental Type 49238

[back to top](#)

Features

- Logic Level Gate Drive
- Internal Voltage Clamp
- ESD Gate Protection
- Max T<sub>J</sub> = 175°C
- SCIS Energy = 300mJ at T<sub>J</sub> = 25°C

[back to top](#)

Applications

Related Links

[Request samples](#)

[How to order products](#)

[Product Change Notices \(PCNs\)](#)

[Support](#)

[Distributor and field sales representatives](#)

[Quality and reliability](#)

[Design tools](#)

Datasheet

[Download this datasheet](#)



[e-mail this datasheet](#)



This page [Print version](#)

[technical information](#)

[buy products](#)

[technical support](#)

[my Fairchild](#)

[company](#)

- Automotive Ignition Coil Driver Circuits
- Coil-On Plug Applications

[back to top](#)

Product status/pricing/packaging

Product	Product status	Package type	Leads	Package marking	Packing method
HGTP14N44G3VL	Full Production	TO-220	3	\$Y&Z&3&T 14N44GV	RAIL

[back to top](#)

[Home](#) | [Find products](#) | [Technical information](#) | [Buy products](#) | [Support](#) | [Company](#) | [Contact us](#) | [Site index](#) | [Privacy policy](#)

[© Copyright 2002 Fairchild Semiconductor](#)