

# EAC10

## 10 x 32 mm high breaking capacity fuse



### Product features

- 10 x 32 mm fuse
- Current rating: 40 A to 63 A
- Up to 500 Vac rating
- High breaking capacity for high energy application
- Cartridge, bolt-down terminal and PCB terminal options available

### Applications

- Uninterruptible power supplies (UPS)
- 3-phase EVSE and charging infrastructure
- Motor protection
- Vac input protection in rectifiers
- Vac output in inverters

### Agency information

cURus Recognition file number: E91958 for for EAC10-XX-PCB



### Environmental compliance



### Ordering part number

**EAC10-40-PCB**

Family code

Ampere rating

Option code

### Option code

None - Cartridge fuse without lead terminal

PCB - PCB terminal

T - Bolt-down terminal

**Electrical characteristics**

**Current and time characteristics**

1.0 I <sub>n</sub>	1 hour minimum
2.0 I <sub>n</sub>	120 seconds maximum

**Product specifications**

Part number	Rated voltage	Rated current	Breaking capacity	Typical cold resistance <sup>1</sup> (mOhms)	Power Loss at 1.0 I <sub>n</sub> (W)
EAC10-40	500 Vac 250 Vac	40 A	2000 A @ 500 Vac 10000 A @ 250 Vac	1.71	4.7
EAC10-50	500 Vac 250 Vac	50 A	2000 A @ 500 Vac 10000 A @ 250 Vac	1.33	5.7
EAC10-63	500 Vac 250 Vac	63 A	2000 A @ 500 Vac 10000 A @ 250 Vac	1.05	7.5

1. DC Cold Resistance measured at <10% of rated current in the ambient temperature of +25 °C

**Dimensions- mm**

Drawing not to scale

**Cartridge version**

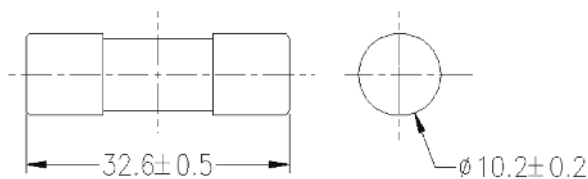

**PCB terminal version**

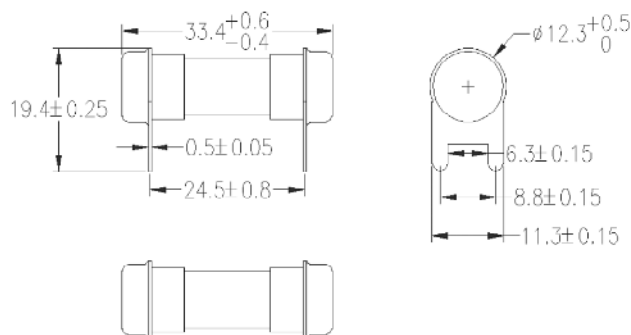

**Bolt version**

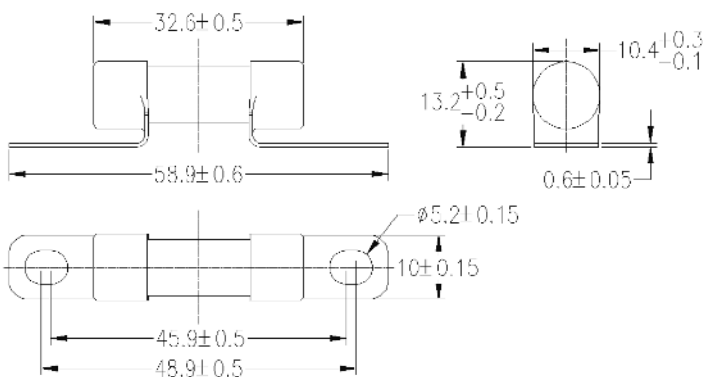

**Recommended PCB layout**

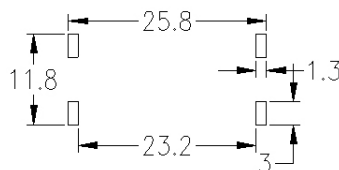

**Part marking** (Example: EAC10-63)



Note: recommend tightening torque is 3.5-4 Nm for M5 screw

### General specifications

---

Mechanical vibration: MIL-STD-202, Method 201, For EAC10-XX; EAC10-XX-PCB and EAC10-XX-T

---

Thermal shock: MIL-STD-202, Method 107, Test Condition B (5 cycles -65°C to 125°C), For EAC10-XX; EAC10-XX-PCB and EAC10-XX-T

---

Humidity: MIL-STD-202, Method 103, Test Condition A: 95% RH and 40 °C for 240 hours, For EAC10-XX; EAC10-XX-PCB and EAC10-XX-T

---

Salt spray: MIL-STD-202, Method 101 Test condition B, For EAC10-XX; EAC10-XX-PCB and EAC10-XX-T

---

Thermal shock resistance: JASO D622 6.3.6, For EAC10-XX-PCB and EAC10-XX-T only

---

Transient current intermittent cycle durability: JASO D622 6.3.2, For EAC10-XX-PCB and EAC10-XX-T only

---

Heat resistance to soldering: MIL-STD-202 Method 210, For EAC10-XX-PCB only

---

Terminal strength: MIL-STD-202, Method 211, Test Condition A, For EAC10-XX-T only

---

Lead solderability: MIL-STD-202, Method 208, For EAC10-XX-PCB only

---

### Packaging information - mm

45 pcs in a plastic tray, 10 trays (450 pcs) in a carton

**Temperature derating curve**

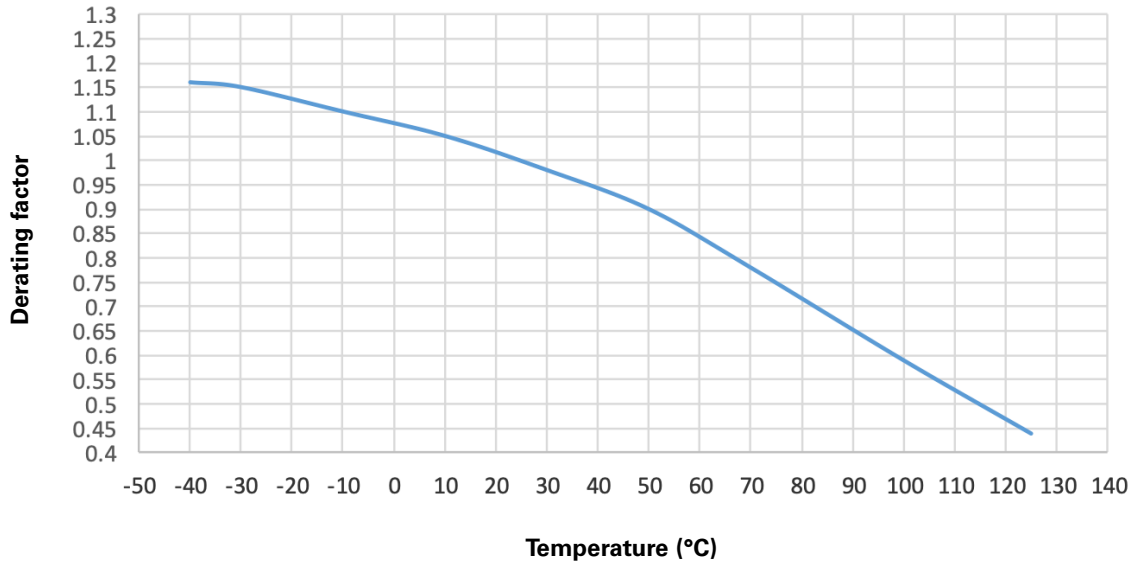

**Current vs. time curve**

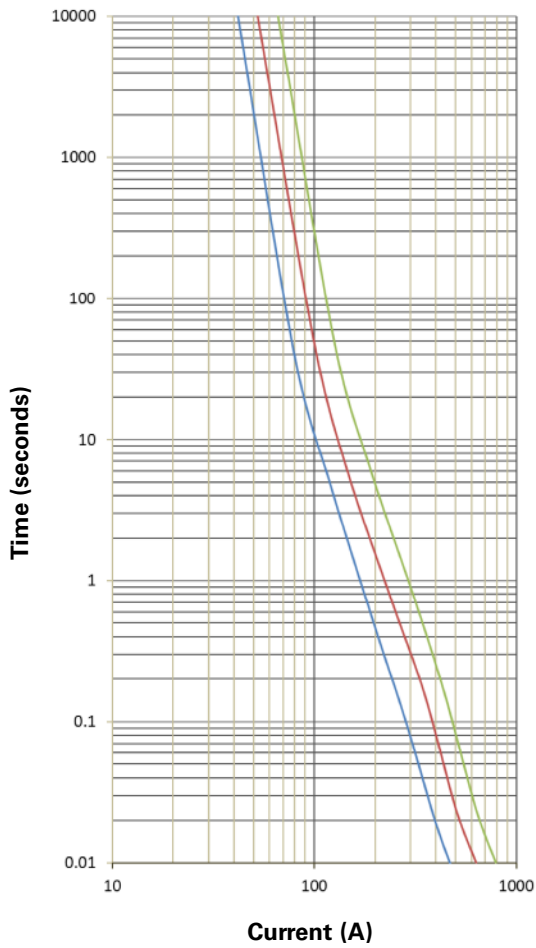

**I²t and time curve**

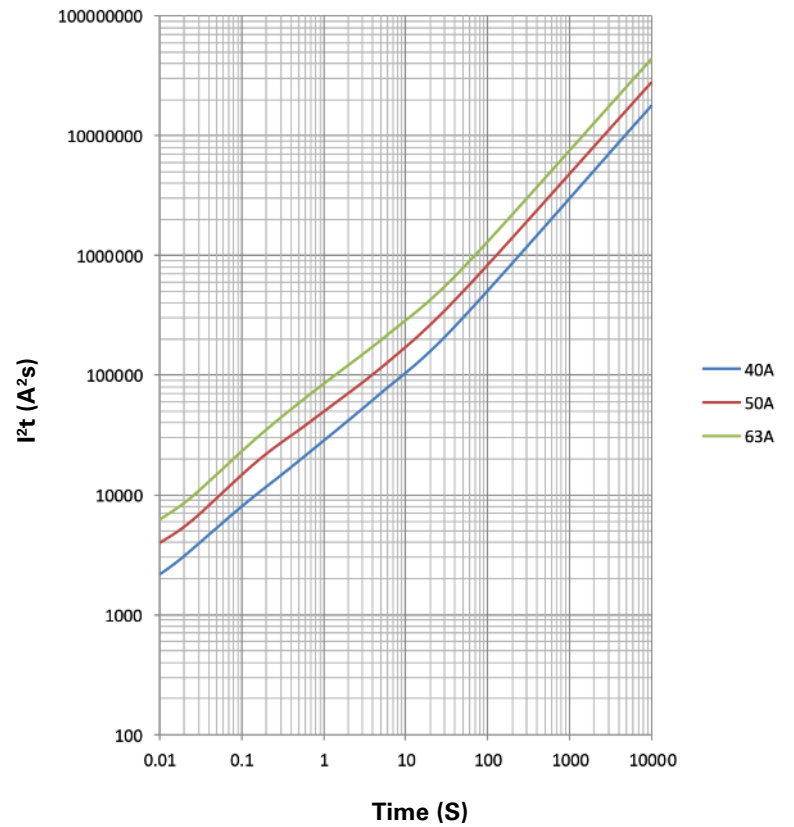

**I<sup>2</sup>t and current curve**

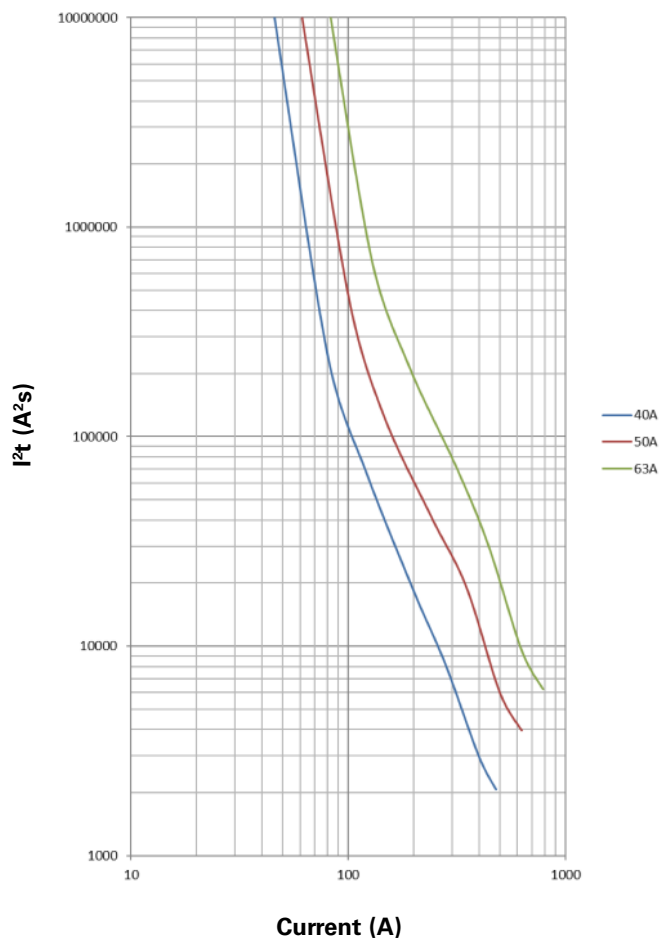

**Wave solder profile--PCB version only**

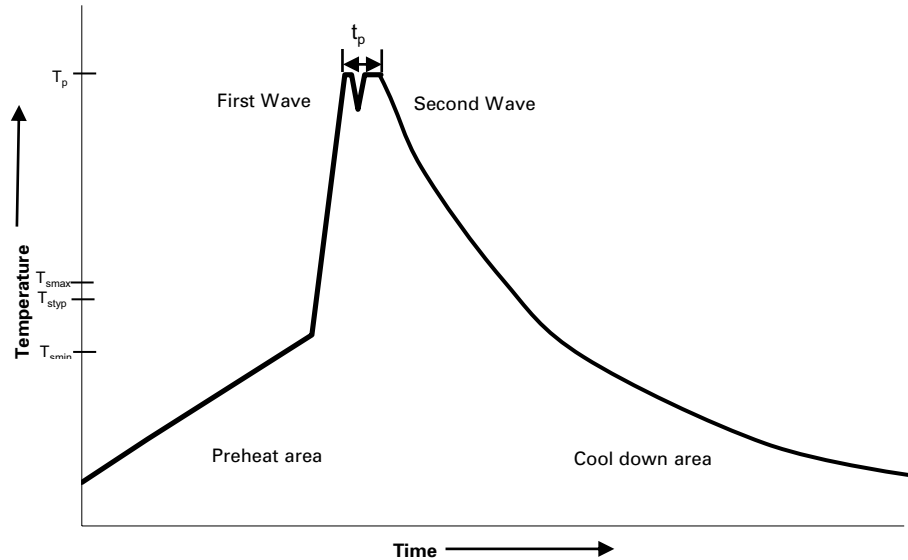

**Reference EN 61760-1:2006**

Profile feature	Standard SnPb solder	Lead (Pb) free solder
Preheat		
• Temperature min. ( $T_{smin}$ )	100 °C	100 °C
• Temperature typ. ( $T_{styp}$ )	120 °C	120 °C
• Temperature max. ( $T_{smax}$ )	130 °C	130 °C
• Time ( $T_{smin}$ to $T_{smax}$ ) ( $t_s$ )	70 seconds	70 seconds
$\Delta$ preheat to max Temperature	150 °C max.	150 °C max.
Peak temperature ( $T_p$ )*	235 °C – 260 °C	250 °C – 260 °C
Time at peak temperature ( $t_p$ )	10 seconds max 5 seconds max each wave	10 seconds max 5 seconds max each wave
Ramp-down rate	~ 2 K/s min ~3.5 K/s typ ~5 K/s max	~ 2 K/s min ~3.5 K/s typ ~5 K/s max
Time 25 °C to 25 °C	4 minutes	4 minutes

**Manual solder**

+350 °C (4-5 seconds by soldering iron), generally manual/hand soldering is not recommended.

Life Support Policy: Eaton does not authorize the use of any of its products for use in life support devices or systems without the express written approval of an officer of the Company. Life support systems are devices which support or sustain life, and whose failure to perform, when properly used in accordance with instructions for use provided in the labeling, can be reasonably expected to result in significant injury to the user.

Eaton reserves the right, without notice, to change design or construction of any products and to discontinue or limit distribution of any products. Eaton also reserves the right to change or update, without notice, any technical information contained in this bulletin.

**Eaton**  
**Electronics Division**  
1000 Eaton Boulevard  
Cleveland, OH 44122  
United States  
Eaton.com/electronics

© 2022 Eaton  
All Rights Reserved  
Printed in USA  
Publication No. ELX1216 BU-ELX22076  
August 2022

Eaton is a registered trademark.  
All other trademarks are property of their respective owners.

Follow us on social media to get the latest product and support information.

