

UNLESS OTHERWISE NOTED  
 DIMENSIONS ARE IN INCHES TOLERANCES ARE:  
 ONE PLACE DECIMALS ± .1[.25] THREE PLACE DECIMALS ± .005[.127]  
 TWO PLACE DECIMALS ± .01[.25] FOUR PLACE DECIMALS ± .0020[.051] ANGLES ± 2°

TITLE:  
 .200 SOCKET  
 POWER ASSEMBLY

DWG NO:  
 PSS-XX-XX-X-X-XX  
 SHEET 1 OF 2

DO NOT SCALE FROM THIS PRINT

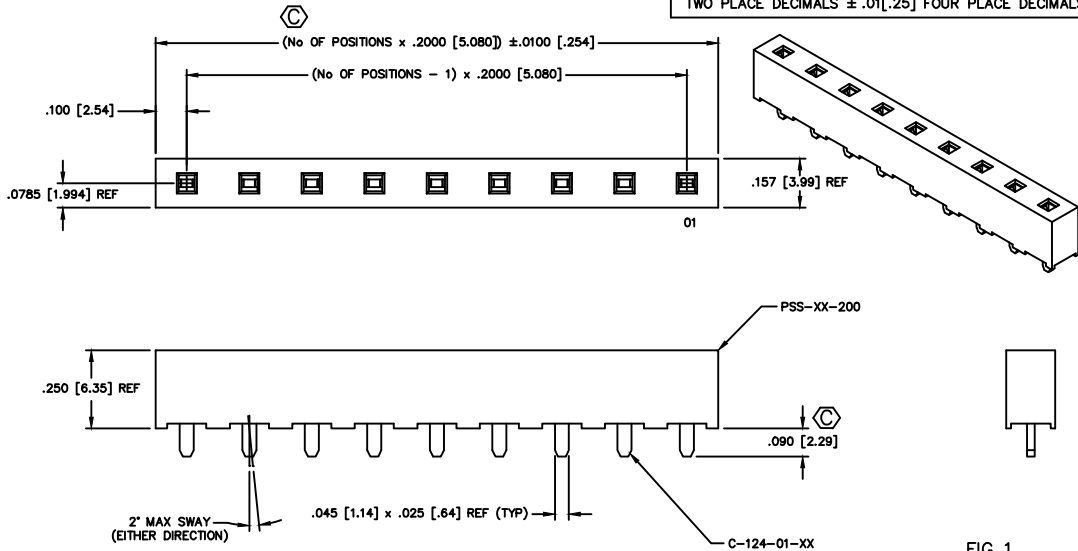

FIG 1  
 -01 LEAD STYLE

PSS-XX-XX-X-X-X-XX

No OF POSITIONS  
 -02 THRU -20

LEAD STYLE  
 -01: .090 TAIL (SEE FIG 1)  
 (USE C-124-XX-XX)  
 -02: SURFACE MOUNT (SEE FIG 2)  
 (USE C-124-XX-XX)

PACKAGING  
 BLANK: TUBES (SEE NOTE 7)  
 -TR: TAPE & REEL  
 (SEE NOTES 8 & 9)  
 (AVAILABLE ON -02 LEAD  
 STYLE, -02 THRU -14  
 POSITIONS ONLY)  
 -FR: FULL REEL QTY TAPE & REEL  
 (SEE NOTES 8 & 9)  
 (AVAILABLE ON -02 LEAD  
 STYLE, -02 THRU -14  
 POSITIONS ONLY)  
 PICK & PLACE OPTION  
 -K: POLYIMIDE  
 FILM PAD (SEE  
 SHEET TWO)

PLATING SPECIFICATION  
 -T: TIN (USE C-124-XX-T)  
 -TM: MATTE TIN (USE C-124-XX-T)  
 -H: HEAVY GOLD (USE C-124-XX-H)

ROW SPECIFICATION  
 -S: SINGLE ROW  
 (USE PSS-20-200)

- NOTES:
1. MAX ALLOWABLE BOW: .005 IN/IN AFTER ASSEMBLY
  2. PUSHOUT FORCE SHALL BE: 2 lb MINIMUM.
  3. (C) REPRESENTS A CRITICAL DIMENSION.
  4. INSERTION FORCE: 1.75 LB AVG
  5. WITHDRAWAL FORCE: 1.25 LB AVG
  6. ENDWALL THICKNESS: .021
  7. TUBES ARE STANDARD PACKAGING.
  8. ORDERS WILL BE PACKAGED ACCORDING TO THE SAMTEC PACKAGING EFFICIENCY STANDARDS (SPES) FOUND ON WWW.SAMTEC.COM.
  9. ATTACH LABEL TO EACH REEL.

FIG 2  
 -02: SURFACE MOUNT  
 (SAME AS FIG 1 UNLESS OTHERWISE STATED)

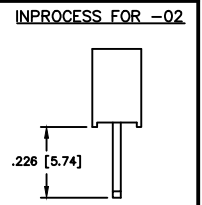
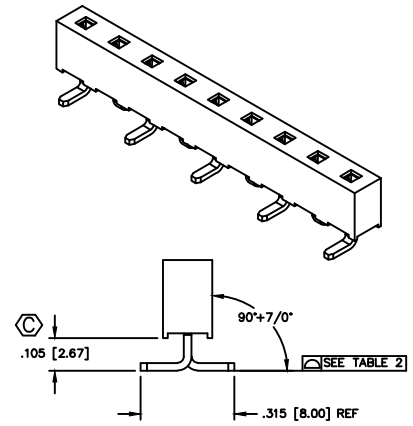
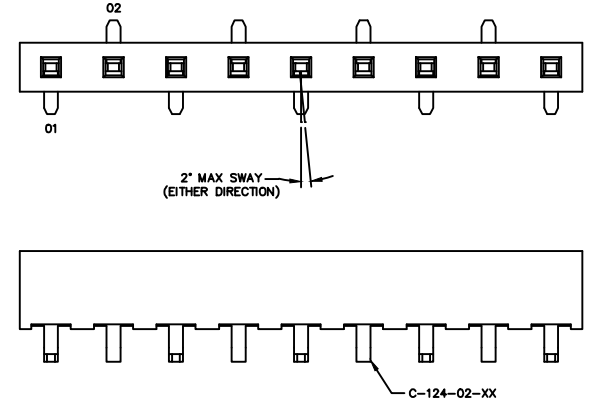

TABLE 2

No OF POS	COPLANARITY
02-14	.006
15-20	.008

PACKAGING VIEWS

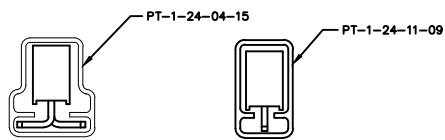

TABLE 1

LEAD STYLE	PACKAGING TUBE	PLUG
-01	PT-1-24-11-09	TP-09
-02	PT-1-24-04-15	TP-03

**PROPRIETARY NOTE**  
 THIS DOCUMENT CONTAINS INFORMATION CONFIDENTIAL AND PROPRIETARY TO SAMTEC INC. AND SHALL NOT BE REPRODUCED OR TRANSMITTED IN ANY FORM OR BY ANY MEANS, ELECTRONIC OR MECHANICAL, INCLUDING PHOTOCOPYING, RECORDING, OR BY ANY INFORMATION STORAGE AND RETRIEVAL SYSTEM, WITHOUT THE EXPRESS WRITTEN CONSENT OF SAMTEC INC.

MATERIAL:  
 INSULATOR: VECTRA E130i  
 COLOR: BLACK  
 CONTACT: BeCu 174 HT

MAX FLASH ALLOWED: .020 [.51]



520 PARK EAST BLVD. NEW ALBANY, INDIANA 47150  
 PHONE (812) 944-6733 P.O. BOX 1147  
 CODE 55322

MADE BY:  
 PURVIS 08-13-98  
 PSS-XX-XX-X-X-XX  
 SHEET 1 OF 2