

# ***User's Guide for bq25505 Battery Charger Evaluation Module for Energy Harvesting***

This user's guide describes the bq25505 evaluation module (EVM), how to perform a stand-alone evaluation and how to allow the EVM to interface with the system and host. The boost charger output is configured to deliver up to 4.2-V maximum voltage to its output, VSTOR, using external resistors. This voltage is applied to the storage element as long as the storage element voltage at VBAT\_SEC is above the internally programmed undervoltage of 2 V. The VBAT\_OK indicator toggles high when VSTOR ramps up to 3 V and toggles low when VSTOR ramps down to 2.8 V.

### **Contents**

1	Introduction .....	2
	1.1 EVM Features .....	2
	1.2 General Description .....	2
	1.3 Design and Evaluation Considerations .....	3
	1.4 bq25505EVM Schematic.....	4
	1.5 EVM I/O Connections .....	5
2	EVM Performance Specification Summary.....	7
3	Test and Measurement Summary .....	7
	3.1 Test Setups and Results.....	8
4	Bill of Materials and Board Layout .....	15
	4.1 Bill of Materials .....	15
	4.2 EVM Board Layout .....	16
5	PCB Layout Guideline .....	20

### **List of Figures**

1	bq25505EVM Schematic.....	4
2	Test Setup for Measuring Boost Charger Efficiency .....	9
3	Charger Efficiency versus Input Voltage.....	9
4	Charger Efficiency versus Input Current .....	10
5	Test Setup for Measuring Charger Operation .....	11
6	Charger Operational Waveforms During Battery Charging .....	11
7	Test Setup.....	12
8	Switching from Primary to Secondary Battery.....	13
9	Test Setup for Charging a Super Capacitor on VBAT_SEC.....	13
10	Charging a Super Cap on VBAT_SEC .....	14
11	EVM PCB Top Silk .....	16
12	EVM PCB Top Assembly.....	17
13	EVM PCB Top Layer .....	18
14	EVM PCB Bottom Layer.....	19

### **List of Tables**

1	I/O Connections and Configuration for Evaluation of bq25505 EVM .....	5
2	Bill of Materials .....	15

## 1 Introduction

### 1.1 EVM Features

- Evaluation module for bq25505
- Ultra-low power boost converter/charger with battery management for energy harvester applications
- Resistor-programmable settings for overvoltage providing flexible battery management
- Programmable push-pull output indicator for battery status (VBAT\_OK)
- Test points for key signals available for testing purpose – easy probe hook-up
- Jumpers available – easy to change settings

### 1.2 General Description

The bq25505 is an integrated energy harvesting Nano-Power management solution that is well suited for meeting the special needs of ultra-low power applications. The product is specifically designed to efficiently acquire and manage the microwatts ( $\mu\text{W}$ ) to milliwatts (mW) of power generated from a variety of high output impedance (Hi-Z) DC sources like photovoltaic (solar) or thermal electric generators; or with an AC/DC rectifier, a piezoelectric generator. The bq25505 implements a highly efficient, pulse-frequency modulated (PFM) boost converter/charger targeted toward products and systems, such as wireless sensor networks (WSN) which have stringent power and operational demands. Assuming a depleted storage element has been attached, the bq25505 DC-DC boost converter/charger that requires only microwatts of power to begin operating in cold-start mode. Once the boost converter output, VSTOR, reaches  $\sim 1.8\text{ V}$  and can now power the converter, the main boost converter can now more efficiently extract power from low voltage output harvesters such as thermoelectric generators (TEGs) or single- and dual-cell solar panels. For example, assuming the Hi-Z input source can provide at least  $5\ \mu\text{W}$  typical and the load on VSTOR (including the storage element leakage current) is less than  $1\ \mu\text{A}$  of leakage current, the boost converter can be started with VIN\_DC as low as  $330\text{ mV}$  typical, and once VSTOR reaches  $1.8\text{ V}$ , can continue to harvest energy down to  $\text{VIN\_DC} = 120\text{ mV}$ .

Hi-Z DC sources have a maximum output power point (MPP) that varies with ambient conditions. For example, a solar panel's MPP varies with the amount of light on the panel and with temperature. The MPP is listed by the harvesting source manufacturer as a percentage of its open circuit (OC) voltage. Therefore, the bq25505 implements a programmable maximum power point tracking (MPPT) sampling network to optimize the transfer of power into the device. The bq25505 periodically samples the open circuit input voltage every 16 seconds by disabling the boost converter for 256 ms and stores the programmed MPP ratio of the OC voltage on the external reference capacitor (C2) at VREF\_SAMP. Typically, solar cells are at their MPP when loaded to  $\sim 70\text{--}80\%$  of their OC voltage and TEGs at  $\sim 50\%$ . While the storage element is less than the user programmed maximum voltage (VBAT\_OV), the boost converter loads the harvesting source until VIN\_DC reaches the MPP (voltage at VREF\_SAMP). This results in the boost charger regulating the input voltage of the converter until the output reaches VBAT\_SEC\_OV, thus transferring the maximum amount of power currently available per ambient conditions to the output.

The battery undervoltage, VBAT\_UV, threshold is checked continuously to ensure that the internal battery FET, connecting VSTOR to VBAT\_SEC, does not turn on until VSTOR is above the VBAT\_UV threshold ( $2\text{ V}$ ). The overvoltage (VBAT\_OV) setting initially is lower than the programmed value at startup (varies on conditions) and is updated after the first  $\sim 32\text{ ms}$ . Subsequent updates are every  $\sim 64\text{ ms}$ . The VBAT\_OV threshold sets maximum voltage on VSTOR and the boost converter stops switching when the voltage on VSTOR reaches the VBAT\_OV threshold. The open circuit input voltage (VIN\_OC) is measured every  $\sim 16$  seconds in order for the Maximum Power Point Tracking (MPPT) circuit to sample and hold the input regulation voltage. This periodic update continually optimizes maximum power delivery based on the harvesting conditions.

The bq25505 was designed with the flexibility to support a variety of energy storage elements. The availability of the sources from which harvesters extract their energy can often be sporadic or time-varying. Systems will typically need some type of energy storage element, such as a re-chargeable battery, super capacitor, or conventional capacitor. The storage element will make certain constant power is available when needed for the systems. In general, the storage element also allows the system to handle any peak currents that can not directly come from the input source. It is important to remember that batteries and super capacitors can have significant leakage currents that need to be included with determining the loading on VSTOR.

To prevent damage to a customer's storage element, both maximum and minimum voltages are monitored against the internally programmed undervoltage (VBAT\_UV) and user programmed overvoltage (VBAT\_OV) levels.

To further assist users in the strict management of their energy budgets, the bq25505 toggles a user programmable battery good flag (VBAT\_OK), checked every 64 ms, to signal the microprocessor when the voltage on an energy storage element or capacitor has risen above (OK\_HYST threshold) or dropped below (OK\_PROG threshold) a pre-set critical level. To prevent the system from entering an undervoltage condition or if starting up into a depleted storage element, it is recommended to isolate the system load from VSTOR by using an NFET to invert the BAT\_OK signal so that it drives the gate of PFET, which isolates the system load from VSTOR.

For details, see bq25505 data sheet ([SLUSBJ3](#)).

### 1.3 Design and Evaluation Considerations

This user's guide is not a replacement for the data sheet. Reading the data sheet first will help in understanding the operations and features of this IC. In this document, "secondary rechargeable battery" or "VBAT\_SEC" will be used but one could substitute any appropriate storage element.

#### System Design Tips

Compared to designing systems powered from an AC/DC converter or large battery (for example, low impedance sources), designing systems powered by Hi-Z sources requires that the system load-per-unit time (for example, per day for solar panel) be compared to the expected loading per the same time unit. Often there is not enough real time input harvested power (for example, at night for a solar panel) to run the system in full operation. Therefore, the energy harvesting circuit collects more energy than being drawn by the system when ambient conditions allow and stores that energy in a storage element for later use to power the system. See [SLUC461](#) for an example spreadsheet on how to design a real solar-panel-powered system in three easy steps:

1. Referring the system rail power back to VSTOR
2. Referring the required VSTOR power back to bq255xx input power
3. Computing the minimum solar panel area from the input power requirement

As demonstrated in the spreadsheet, for any boost converter, you must perform a power balance:

$$P_{OUT} / P_{IN} = (V_{STOR} \times I_{STOR}) / (V_{IN} \times I_{IN}) = \eta \quad (1)$$

where  $\eta$  is the estimated efficiency for the same or similar configuration in order to determine the minimum input power needed to supply the desired output power.

This IC is a highly efficient charger for a storage element such as a battery or super capacitor. The main difference between a battery and a super capacitor is the capacity curve. The battery typically has little or no capacity below a certain voltage, whereas the capacitor does have capacity at lower voltages. Both can have significant leakage currents that will appear as a DC load on VSTOR/VBAT\_SEC.

### 1.4 bq25505EVM Schematic

Figure 1 is the schematic for this EVM.

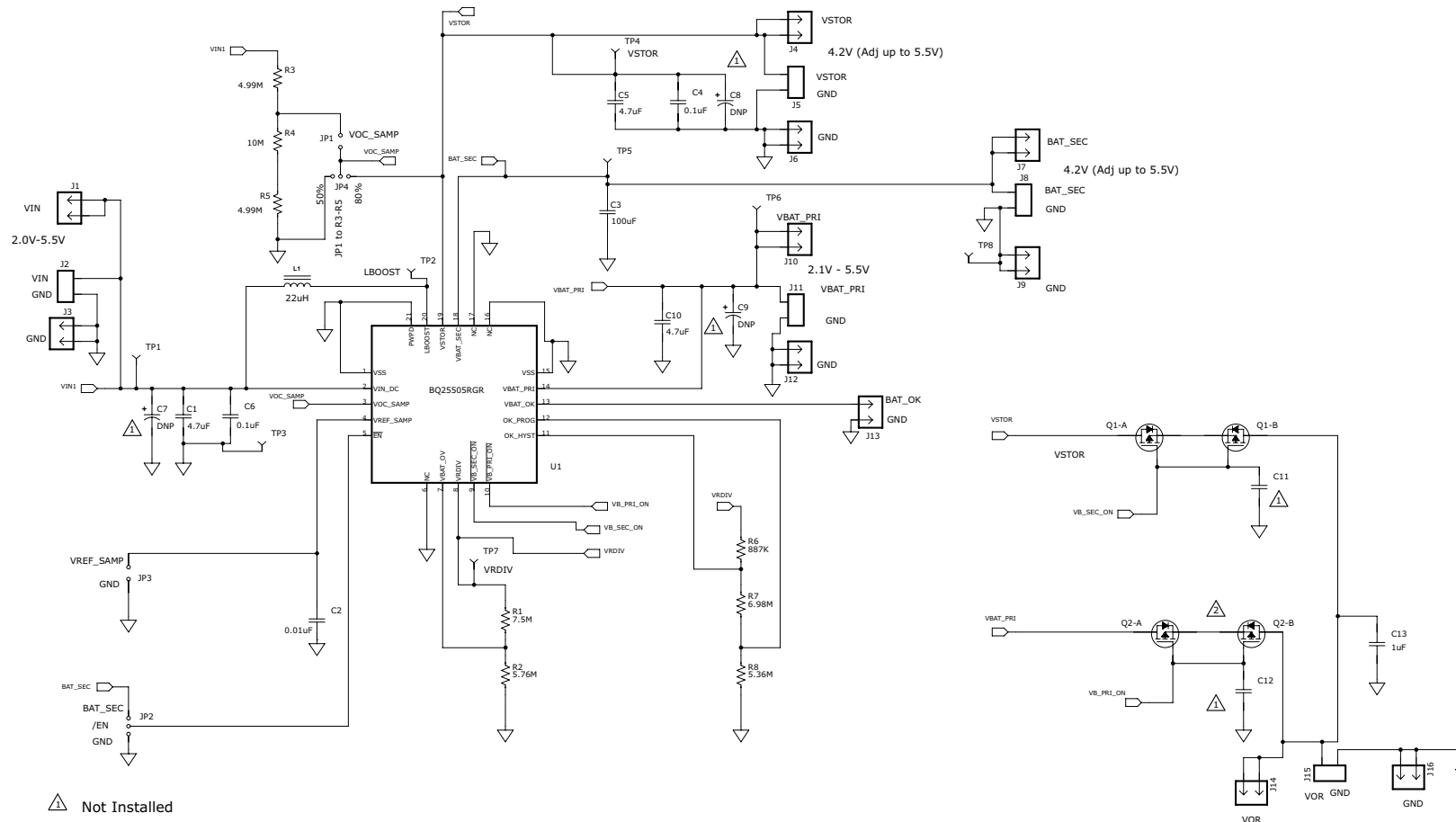

Figure 1. bq25505EVM Schematic

## 1.5 EVM I/O Connections

**Table 1. I/O Connections and Configuration for Evaluation of bq25505 EVM**

REFERENCE DESIGNATOR	DESCRIPTION	COMMENTS / DEFAULT SETTINGS
<b>HEADERS AND TERMINALS</b>		
J1 – VIN	Input source (+)	If VIN_DC is higher than VSTOR and VSTOR is equal to VBAT_OV, the input VIN_DC is pulled to ground through a small resistance to stop further charging of the attached battery or capacitor. It is critical that if this case is expected, the impedance of the source attached to VIN_DC be higher than 20 Ω and not a low impedance source.
J2 – VIN/GND	Input source terminal block	
J3 – GND	Input source return (–)	
J4 – VSTOR	Boost charger output (+)	
J5 – VSTOR/GND	Boost charger output terminal block	
J6 – GND	Boost charger return (–)	
J7– BAT_SEC	Rechargeable storage element connection (+)	
J8 – BAT_SEC/GND	Rechargeable storage element terminal block	
J9 – GND	Rechargeable storage element connection return (–)	
J10 – VBAT_PRI	Non-rechargeable storage element connection (+)	VBAT_PRI is an optional non-rechargeable battery that switches in to the power the system when BAT_SEC drops below the VBAT_OK threshold.
J11 – VBAT_PRI/GND	Non-rechargeable storage element connection terminal block	
J12 – GND	Non-rechargeable storage element connection return (–)	
J13 – BAT_OK/GND	Battery Status Indicator (+/–)	
J14 – VOR	Output of multiplexing switches, either VSTOR or VBAT_PRI (+)	
J15 – VOR/GND	Output of multiplexing switches terminal block	
J16 – GND	Return for output of multiplexing switches (–)	
<b>TEST POINTS</b>		
TP1	Input source, VIN_DC (+)	
TP2	Boost charger switching node	
TP3	Buck converter switching node	
TP4	Boost charger output, VSTOR (+)	
TP5	Rechargeable storage element, VBAT_SEC (+)	
TP6	Non-rechargeable storage element, VBAT_PRI(+)	
TP7	VRDIV node	CAUTION: Providing an additional low impedance current path in parallel with the feedback resistors , for example, with a 10-MΩ scope probe attached, will degrade regulation accuracy.
TP8	Output return (–)	
TP9	Input return (–)	

**Table 1. I/O Connections and Configuration for Evaluation of bq25505 EVM (continued)**

REFERENCE DESIGNATOR	DESCRIPTION	COMMENTS / DEFAULT SETTINGS
<b>JUMPERS</b>		
JP1 – VOC_SAMP	VOC_SAMP = external resistors sized to configure the IC to regulate VIN to 75% of VIN <sub>OC</sub> .	Uninstalled (NOTE: Do not install if JP4 shunt is installed)
JP2 - EN	EN = GND enables the IC. EN = BAT_SEC disables the IC.	EN = GND
JP3 - VREF_SAMP to GND	VREF_SAMP = GND	Uninstalled (NOTE: Providing an additional leakage path for the VREF_SAMP capacitor for example, through a 10-MΩ scope probe attached to VREF_SAMP, will degrade input voltage regulation performance).
JP4 - VOC_SAMP	VOC_SAMP = 80% configures the IC to regulate VIN to 80% of VIN <sub>OC</sub> . VOC_SAMP = 50% configures the IC to regulate VIN to 50% of VIN <sub>OC</sub> .	JP4 = 80% (NOTE: Do not install if JP1 shunt is installed)

## 2 EVM Performance Specification Summary

See Data Sheet “Recommended Operating Conditions” for component adjustments. For details about the resistor programmable settings, see bq25505 data sheet ([SLUSBJ3](#)).

		MIN	NOM	MAX	UNIT
VIN(DC)	DC input voltage into VIN_DC	0.13		4.0	V
VIN_STARTUP(DC)	DC minimum start-up voltage into depleted storage element, no load attached to VSTOR or VOUT and IBAT(LEAK) ≤ 1 μA		330		mV
VBAT_OV	Battery overvoltage Threshold –min and max values include ±2% set point accuracy and ±1% resistor tolerance but excludes effects of output ripple	4.04	4.18	4.32	V
VBAT_OK	OK_HYST indication toggles high when VSTOR ramps up - min and max values include ±2% set point accuracy and ±1% resistor tolerance	2.70	2.79	2.88	V
	OK_PROG indication toggles low when VSTOR ramps down - min and max values include ±2% set point accuracy and ±1% resistor tolerance	2.89	2.99	3.09	V
MPPT	Maximum Power Point Tracking, Resistor Programmed % of Open Circuit Voltage		80%		
CBAT	A 100-μF low leakage ceramic capacitor is installed on the EVM as the minimum recommended equivalent battery capacitance.	100			μF

See [SLUC484](#) spreadsheet tool to assist with modifying the MPPT, VBAT\_OV and VBAT\_OK resistors for your application.

### CAUTION

If changing the board resistors or the capacitor on VREF\_SAMP (C2), it is important to remember that residual solder flux on a board has a resistivity in the 1–20 MΩ range. Therefore, flux remaining in parallel with changed 1–20 MΩ resistors can result in a lower effective resistances, which will produce different operating thresholds than expected. Similarly, flux remaining in parallel with the VREF\_SAMP capacitor provides an additional leakage path, which results in the input voltage regulation set point drooping during the 16-s MPPT cycle. Therefore, it is highly recommended that boards be thoroughly cleaned twice, once after removing the old components and again after installing the new components. If possible, the boards should be cleaned until the wash solution measures ionic contamination greater than 50 MΩ.

## 3 Test and Measurement Summary

### Test Setup Tips

Energy harvesting power sources are high impedance sources. A source-meter configured as a current source with voltage compliance set to the harvester's open circuit voltage is the best way to simulate the harvester. When simulating a Hi-Z energy harvester with low output impedance lab power supply, it is necessary to simulate the harvester's impedance with a physical resistor between the supply, VPS, and VIN\_DC of the EVM. When the MPPT sampling circuit is active, VIN\_DC = VPS = the harvester open circuit voltage (VIN\_OC) because there is no input current to create a drop across the simulated impedance (that is, open circuit); therefore, VPS should be set to the intended harvester's open circuit voltage. When the boost converter is running, it draws only enough current until the voltage at VIN\_DC droops to the MPPT's sampled voltage that is stored at VREF\_SAMP.

The battery (storage element) can be replaced with a simulated battery. Often electronic 4 quadrant loads give erratic results with a “battery charger” due to the charger changing states (fast-charge to termination and refresh) while the electronic load is changing loads to maintain the “battery” voltage. The charging and loading get out of phase and create a large signal oscillation which is due to the 4 quadrant meter. A simple circuit can be used to simulate a battery and can be adjusted for voltage. It consists of load resistor (~10  $\Omega$ , 2 W) to pull the output down to some minimum storage voltage (sinking current part of battery) and a lab supply connected to the BAT pin via a diode. The lab supply biases up the battery voltage to the desired level. It may be necessary to add more capacitance across R1.

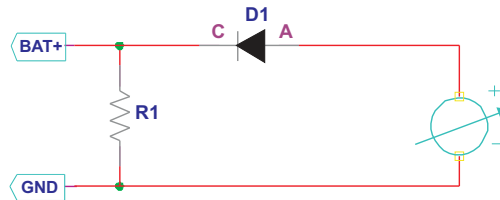

### 3.1 Test Setups and Results

#### 3.1.1 Boost Charger Efficiency

The test setup is shown in [Figure 2](#). The specific equipment used for the test results in [Figure 3](#) and [Figure 4](#) is listed below:

1. VIN\_DC was connected to a Keithley 2420 source-meter configured as a current source with voltage compliance (clamp) set to the open circuit voltage.
2. VSTOR was connected a Keithley 2420 source-meter configured as a voltage source set to the VSTOR voltage. The current sunk by the source-meter was the output current of the charger.
3. VREF\_SAMP was connected to a power supply configured to output the desired input voltage regulation point (that is, the MPPT% times the HiZ source's VOC). No jumper is required on JP4.



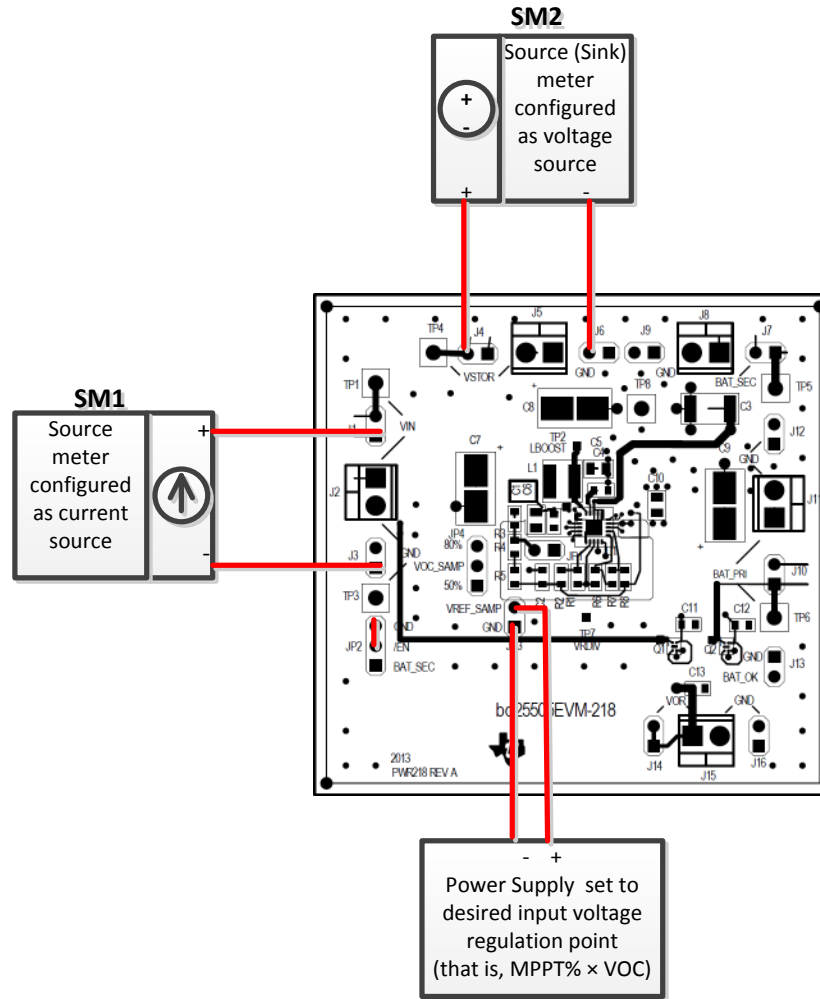

Figure 2. Test Setup for Measuring Boost Charger Efficiency

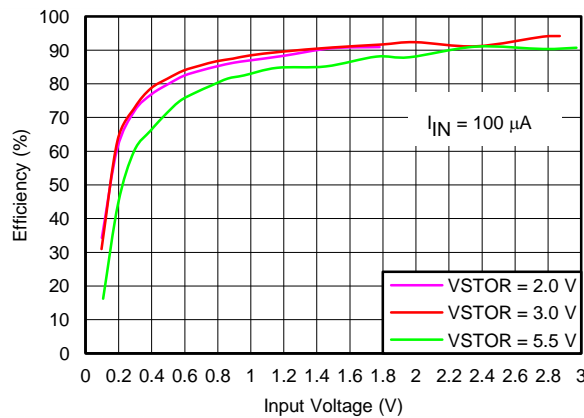
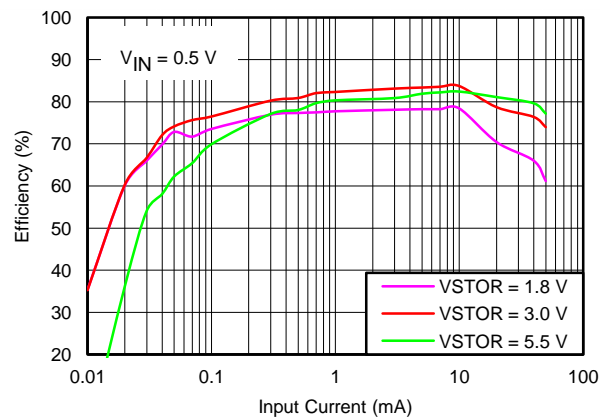

Figure 3. Charger Efficiency versus Input Voltage



**Figure 4. Charger Efficiency versus Input Current**

Because the boost converter regulates input voltage instead of output voltage, uses PFM switching, operates at very low currents, and has MPPT, efficiency cannot be measured using the same test setup as for an output regulating, higher power, fixed-frequency PWM switching boost converter. The VSTOR output must be held at a fixed voltage (below VBAT\_OV threshold) by an external source that is capable of sinking current, with that sunk current being the measured output current. In addition to filtering bursts of current due to PFM switching and the ripple voltage on VIN\_DC due to input voltage regulation, the series input current meter and input voltage meter must be set to filtering/averaging which will result in longer than usual measurement times, but not longer than the 16-s MPPT sample time. Measurements for both VIN and IN will be most accurate when taken at the midpoint of the 16-s MPPT period. Remote sensing by the source-meters is possible but, on the input side, the source-meter output regulation loop and the charger MPPT input regulation loop may interfere with each other and cause the input voltage to oscillate. Adding a large capacitor across VIN\_DC and GND will eliminate this oscillation but the capacitor's leakage current will inflate the input current measurement and result in lower efficiency.

See [SLUA691](#) for a detailed explanation on how to take these and other measurements with source-meters.

### 3.1.2 Boost Charger Operation during Battery Charging

The test setup is shown in [Figure 5](#). The specific equipment used for the test results in [Figure 6](#) is listed below:

1. VIN\_DC and VBAT\_SEC are configured as shown in [Section 3.1.2](#).
2. The boost charger inductor current (IL) was measured by using an oscilloscope current probe across a current loop that was inserted in series with inductor L1.
3. VSTOR's ripple voltage was measured using an oscilloscope voltage probe placed directly across the VSTOR capacitor (C5). The scope probe's standard ground lead was replaced with short lead.
4. VIN\_DC and the LBOOST pin (switching node of the boost charger) were measured by oscilloscope voltage probes connected to TP1 and TP2.

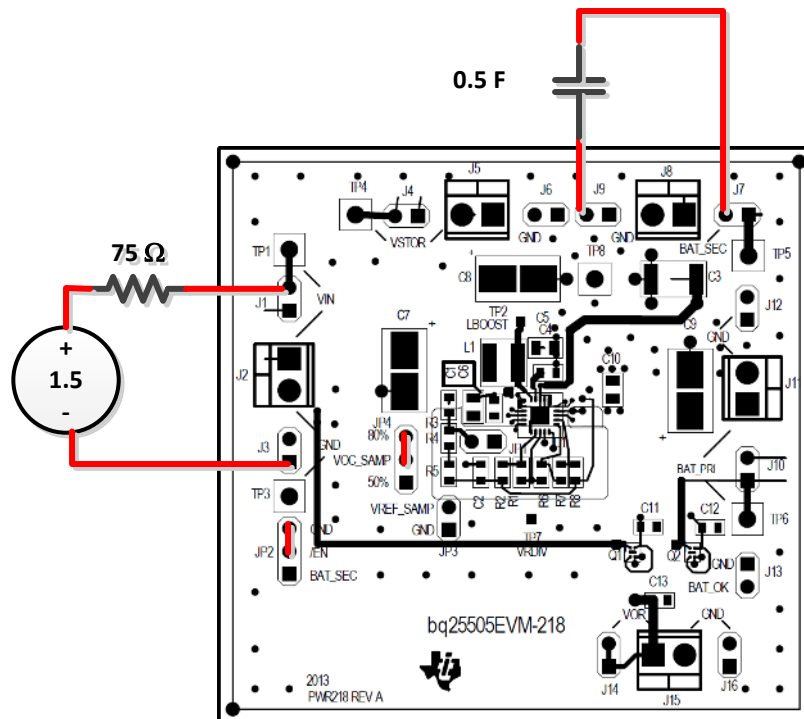

Figure 5. Test Setup for Measuring Charger Operation

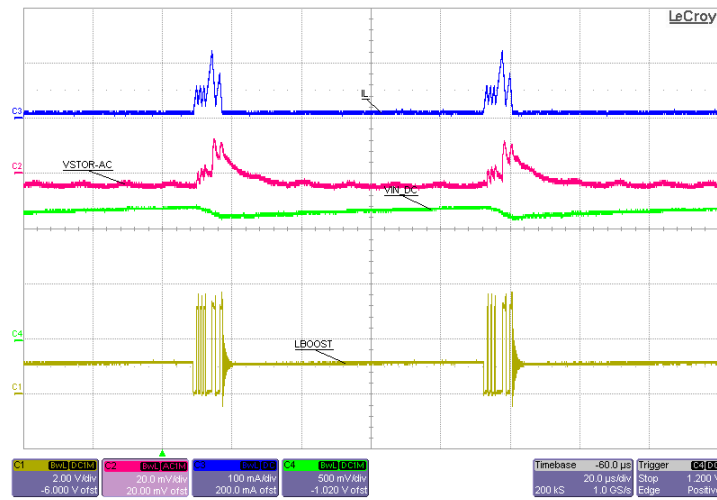

Figure 6. Charger Operational Waveforms During Battery Charging

### 3.1.3 Switching Between Primary and Secondary Batteries

The test setup is shown in [Figure 5](#). The specific equipment used for the test results in [Figure 8](#) is listed below:

1. VIN\_DC, VBAT\_SEC and VBAT\_PRI are configured as shown in [Section 3.1.2](#).
2. The function generator and power amplifier simulated VSTOR charging up and discharging.
3. VBAT\_SEC, VBAT\_PRI, VBAT\_OK and VOR were measured with oscilloscope voltage probes at TP5, TP6, J13 and J14, respectively.

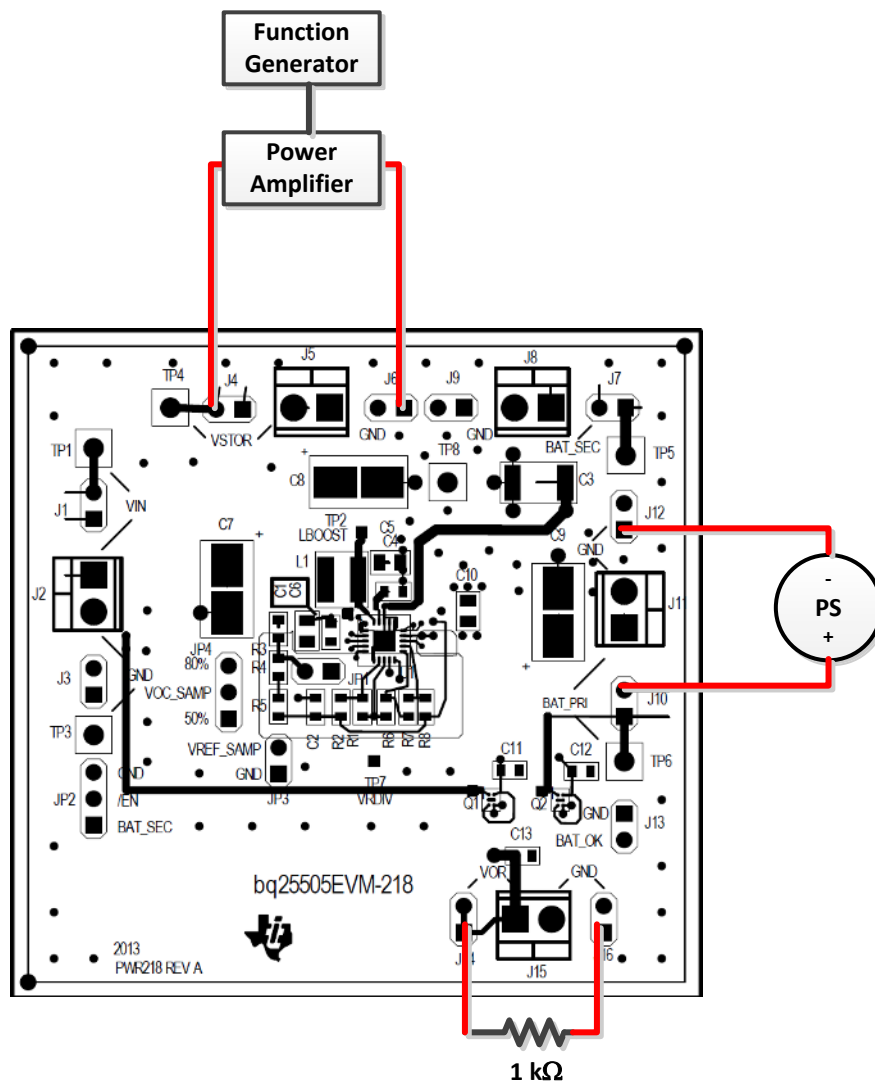

Figure 7. Test Setup

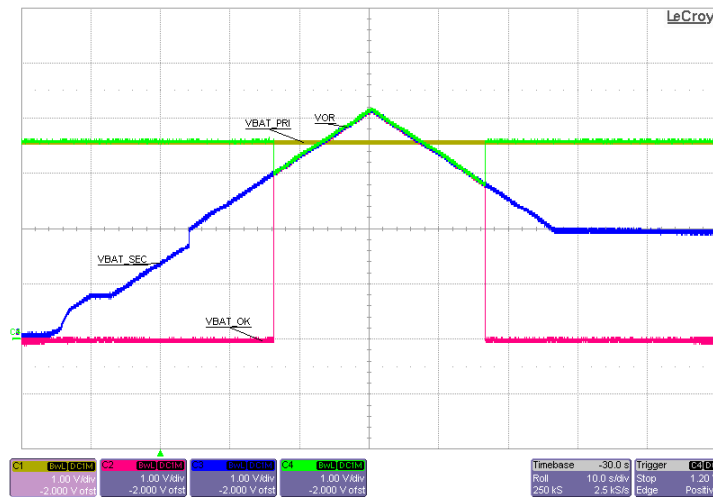

Figure 8. Switching from Primary to Secondary Battery

### Charging a Super Capacitor on VBAT\_SEC

The test setup is shown in Figure 9. The specific equipment used for the test results in Figure 10 is listed below:

1. VIN\_DC was connected to a Keithley 2420 configured as a 1.0-mA current source with 1.2-V voltage compliance.
2. VBAT\_SEC was connected to a 120-mF super capacitor. There were no other loads on VSTOR or VBAT\_SEC.
3. VIN\_DC, VSTOR and VBAT\_SEC were measured with oscilloscope voltage probes connected at TP1, TP4 and TP5 respectively.

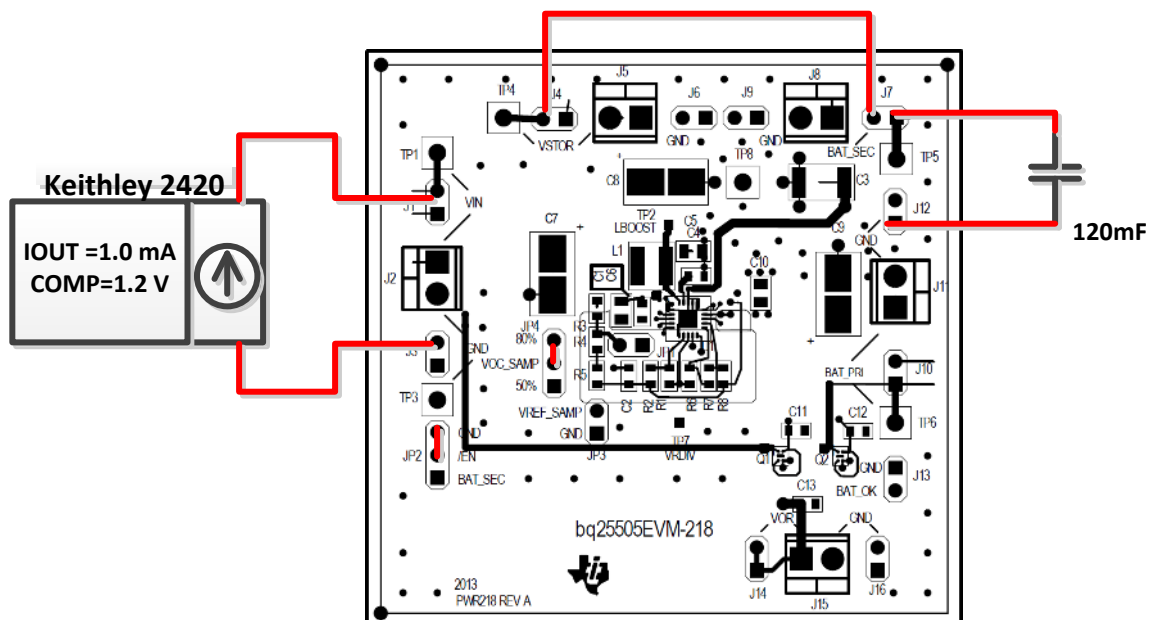
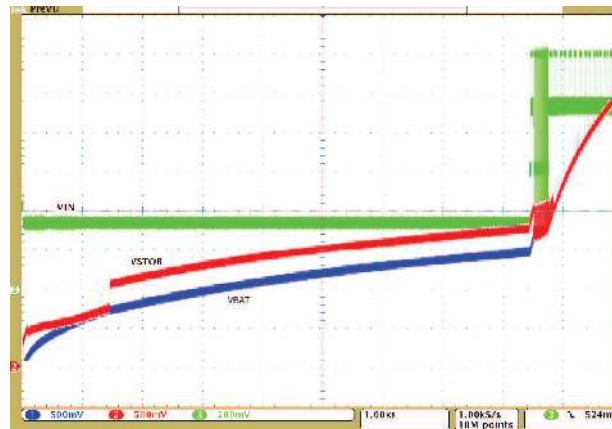

Figure 9. Test Setup for Charging a Super Capacitor on VBAT\_SEC



**Figure 10. Charging a Super Cap on VBAT\_SEC**

### Tips for other Tests and Measurements

The quiescent current during main boost operation, which is basically the current from the battery to the IC, is measured at the VSTOR pin. If a source-meter is not available to make the measurement, connect a 100-k $\Omega$  resistor to VSTOR and connect a 3-V supply from the other end of this resistor to the ground of the EVM. A 10-M $\Omega$  meter can be used to measure the voltage drop across the resistor and calculate the current. No other connections should be made to the EVM and the measurement should be taken after steady state conditions are reached (may take a few minutes). The reading should be much less than 100 nA.

## 4 Bill of Materials and Board Layout

This section contains the bq25505 bill of materials (BOM) and PCB board layout.

### 4.1 Bill of Materials

Table 2 lists the BOM for the bq25505EVM.

**Table 2. Bill of Materials**

COUNT	RefDes	Value	Description	Size	Part Number	MFR
1	C1	4.7uF	Capacitor, Ceramic Chip, 6.3V, X7R, ±10%	805	C0805C475K9RACTU	Kemet
1	C10	4.7uF	Capacitor, Ceramic Chip, 6.3V, X5R, ±20%	603	GRM188R60J475ME19D	Murata
0	C11-12	DNP	Capacitor, Ceramic Chip, 6.3V, X5R, ±20%	603	Engineering Only	n/a
1	C2	0.01u	Capacitor, Ceramic, 50V, X7R, 10%	0603	GRM188R71H103KA01D	Murata
1	C3	100u	Capacitor, Ceramic Chip, 6.3V, X5R, 20%	1812	GRM43SR60J107ME20L	Murata
2	C4 C6	0.1u	Capacitor, Ceramic Chip, 6.3V, X5R, 10%	603	06036D104KAT2A	AVX
1	C5	4.7uF	Capacitor, Ceramic Chip, 10V, X7R, ±10%	805	LMK212B7475KG-T	Taiyo Yuden
0	C7-9	DNP	Capacitor, Electrolytic, Snap Mt., vV	7343 (D)	Engineering Only	n/a
1	C13	1.0uF	Capacitor, Ceramic Chip, 10V, X5R, ±20%	603	GRM188R61A105MA61D	Murata
11	J1 J3-4 J6-7 J9-10 J12-14 J16	PEC02SAAN	Header, Male 2-pin, 100mil spacing,	0.100 inch x 2	PEC02SAAN	Sullins
5	J2 J5 J8 J11 J15	ED555/2DS	Terminal Block, 2-pin, 6-A, 3.5mm	0.27 x 0.25 inch	ED555/2DS	OST
2	JP1 JP3	PEC02SAAN	Header, Male 2-pin, 100mil spacing,	0.100 inch x 2	PEC02SAAN	Sullins
2	JP2 JP4	PEC03SAAN	Header, Male 3-pin, 100mil spacing,	0.100 inch x 3	PEC03SAAN	Sullins
1	L1	22uH	Inductor, SMT, 0.65A, 360mΩ Inductor SMT, 0.36A, 410mΩ	4.0mm x4.0mm x1.80mm 3.8mm x3.8mm x1.65mm	LPS4018-223M 744031220	Coilcraft Würth Elektronik
2	Q1-2	CSD75205W1015	MOSFET, Dual PChan, -20V, 1.2A, 190 milliOhm	CSP 1x1.5mm	CSD75205W1015	TI
1	R1	7.5M	Resistor, Chip, 1/16W, 1%	603	CRCW06037M50FKEA	Vishay Dale
1	R2	5.76M	Resistor, Chip, 1/16W, 1%	603	CRCW06035M76FKEA	Vishay Dale
2	R3 R5	4.99M	Resistor, Chip, 1/16W, 1%	603	CRCW06034M99FKEA	Vishay Dale
1	R4	10M	Resistor, Chip, 1/16W, 1%	603	CRCW060310M0FKEA	Vishay Dale
1	R6	887K	Resistor, Chip, 1/16W, 1%	603	CRCW0603887KFKEA	Vishay Dale
1	R7	6.98M	Resistor, Chip, 1/16W, 1%	603	CRCW06036M98FKEA	Vishay Dale
1	R8	5.36M	Resistor, Chip, 1/16W, 1%	603	CRCW06035M36FKEA	Vishay Dale
4	TP1 TP4-6	5002	Test Point, White, Thru Hole Color Keyed	0.100 x 0.100 inch	5002	Keystone
0	TP2 TP7	DNP	Test Point, 0.020 Hole	0.100 x 0.100 inch	n/a	n/a
2	TP3 TP8	5001	Test Point, Black, Thru Hole Color Keyed	0.100 x 0.100 inch	5001	Keystone
1	U1	BQ25505RGR	IC, Ultra-Low Power Harvester Charger	VQFN	BQ25505RGR	TI
2			Shunt, 100-mil, Black	0.1	929950-00	3M
1	--		PCB, 2.5212 in x 2.6039 in		PWR218	Any





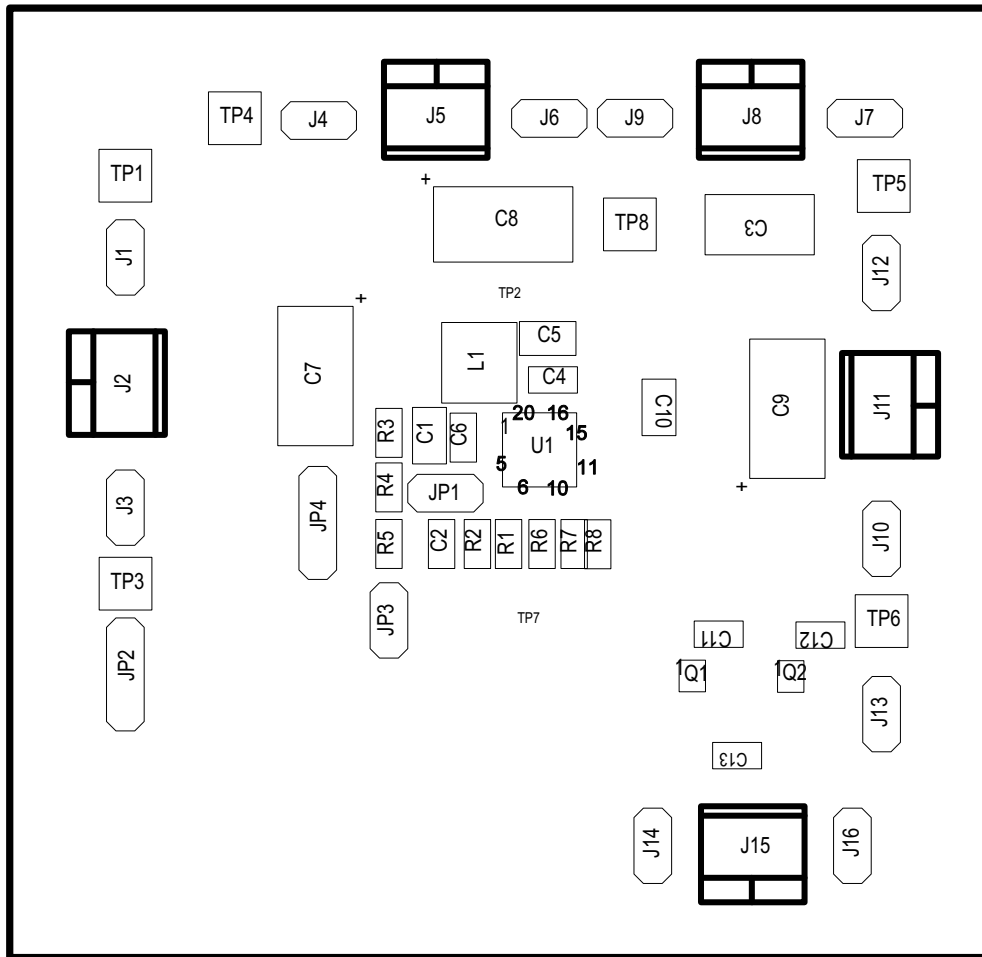

Figure 12. EVM PCB Top Assembly

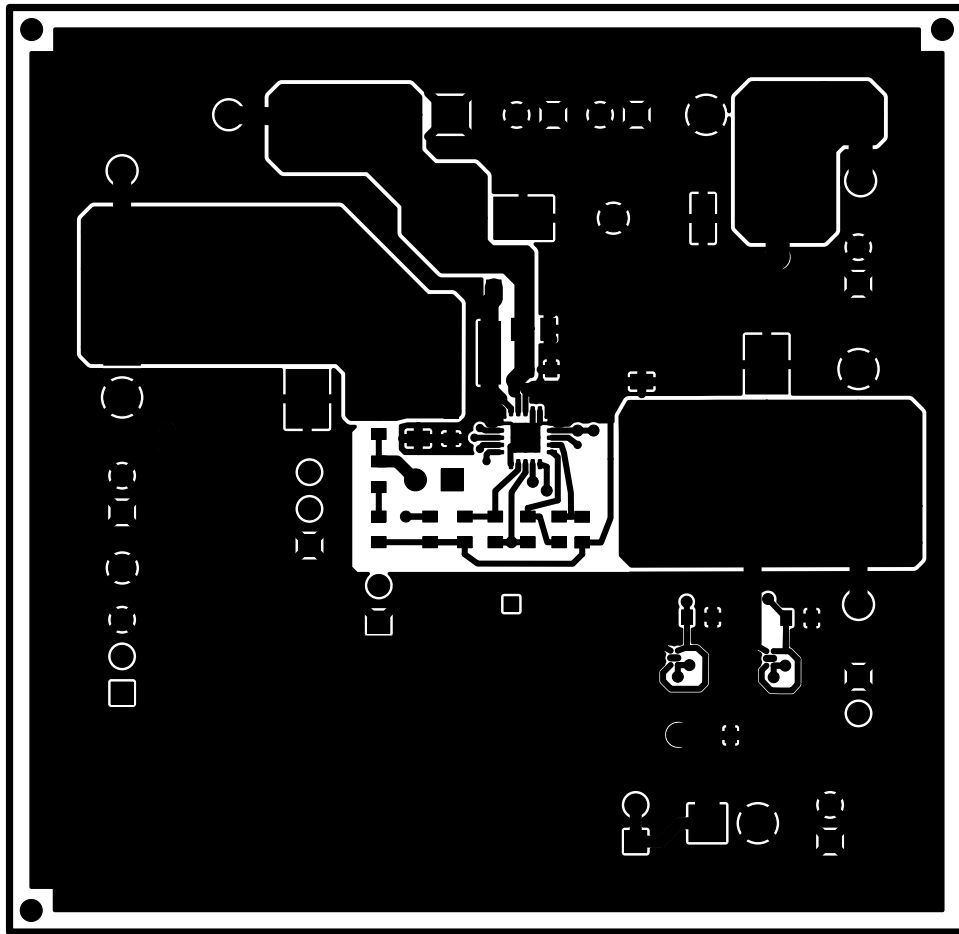

Figure 13. EVM PCB Top Layer

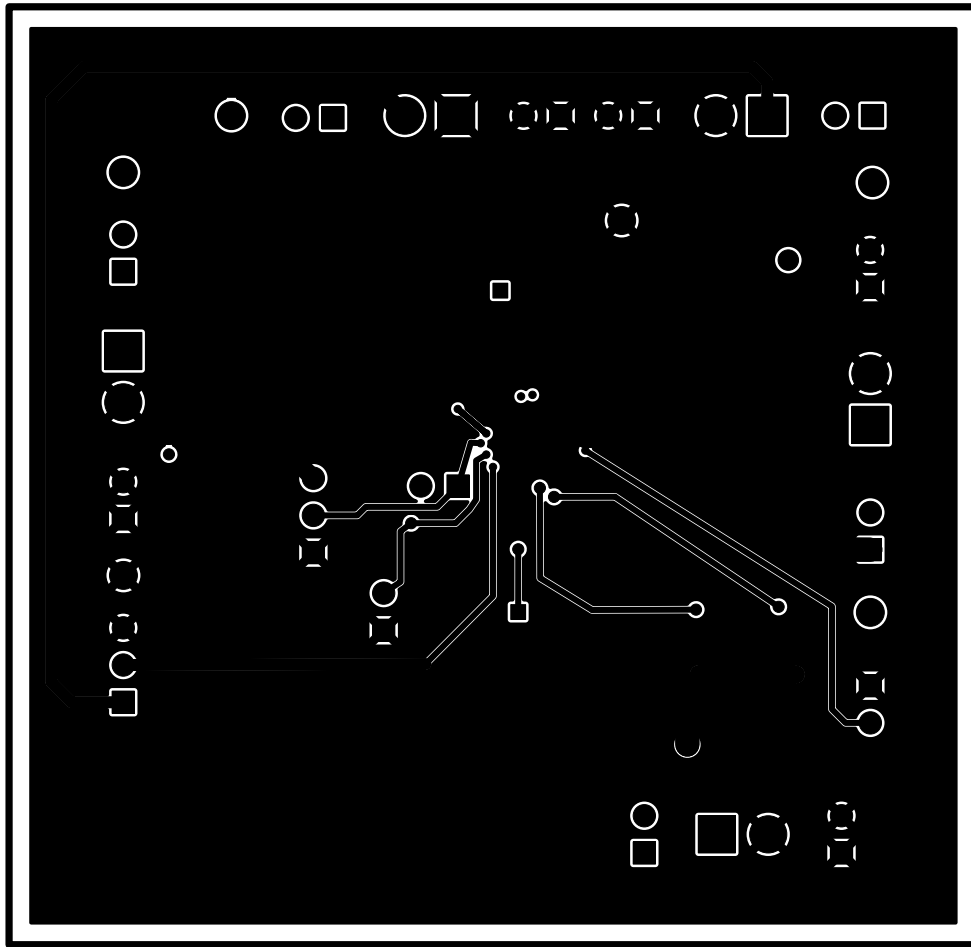

Figure 14. EVM PCB Bottom Layer

## 5 PCB Layout Guideline

As for all switching power supplies, the PCB layout is an important step in the design, especially at high peak currents and high switching frequencies. If the layout is not carefully done, the boost converter/charger and buck converter could show stability problems as well as EMI problems. Therefore, use wide and short traces for the main current path and for the power ground paths. The input and output capacitors as well as the inductors should be placed as close as possible to the IC. For the boost charger, the first priority are the output capacitors, including the 0.1- $\mu$ F bypass capacitor (CBYP), followed by CSTOR, which should be placed as close as possible between VSTOR, pin 19, and VSS, pin 1. Next, the input capacitor, CIN, should be placed as close as possible between VIN\_DC, pin 2, and VSS, pin 1. Last in priority is the boost converter inductor, L1, which should be placed close to LBOOST, pin 20, and VIN\_DC, pin 2. It is best to use vias and bottom traces for connecting the inductors to their respective pins instead of the capacitors.

To minimize noise pickup by the high impedance voltage setting nodes (VBAT\_OV, OK\_PROG, and OK\_HYST), the external resistors should be placed so that the traces connecting the midpoints of each divider to their respective pins are as short as possible. When laying out the non-power ground return paths (for example from resistors and CREF), it is recommended to use short traces as well, separated from the power ground traces and connected to VSS pin 15. This avoids ground shift problems, which can occur due to superimposition of power ground current and control ground current. The PowerPAD™ should not be used as a power ground return path.

The remaining pins are either NC pins, that should be connected to the PowerPad as shown below, or digital signals with minimal layout restrictions.

In order to maximize efficiency at light load, the use of voltage level setting resistors > 1 M $\Omega$  is recommended. However, during board assembly, contaminants such as solder flux and even some board cleaning agents can leave residue that may form parasitic resistors across the physical resistors or from one end of a resistor to ground, especially in humid, fast airflow environments. This can result in the voltage regulation and threshold levels changing significantly from those expected per the installed resistor values. Therefore, it is recommended that no ground planes be poured near the voltage setting resistors. In addition, the boards must be carefully cleaned, possibly rotated at least once during cleaning, and then rinsed with de-ionized water until the ionic contamination of that water is well above 50  $\Omega$ . If this is not feasible, then it is recommended that the sum of the voltage setting resistors be reduced to at least 5X below the measured ionic contamination.

### Revision History

Changes from Original (September 2013) to A Revision	Page
• Changed contents in the bill of materials .....	15

NOTE: Page numbers for previous revisions may differ from page numbers in the current version.

## ADDITIONAL TERMS AND CONDITIONS, WARNINGS, RESTRICTIONS, AND DISCLAIMERS FOR EVALUATION MODULES

Texas Instruments Incorporated (TI) markets, sells, and loans all evaluation boards, kits, and/or modules (EVMs) pursuant to, and user expressly acknowledges, represents, and agrees, and takes sole responsibility and risk with respect to, the following:

1. User agrees and acknowledges that EVMs are intended to be handled and used for feasibility evaluation only in laboratory and/or development environments. Notwithstanding the foregoing, in certain instances, TI makes certain EVMs available to users that do not handle and use EVMs solely for feasibility evaluation only in laboratory and/or development environments, but may use EVMs in a hobbyist environment. All EVMs made available to hobbyist users are FCC certified, as applicable. Hobbyist users acknowledge, agree, and shall comply with all applicable terms, conditions, warnings, and restrictions in this document and are subject to the disclaimer and indemnity provisions included in this document.
2. Unless otherwise indicated, EVMs are not finished products and not intended for consumer use. EVMs are intended solely for use by technically qualified electronics experts who are familiar with the dangers and application risks associated with handling electrical mechanical components, systems, and subsystems.
3. User agrees that EVMs shall not be used as, or incorporated into, all or any part of a finished product.
4. User agrees and acknowledges that certain EVMs may not be designed or manufactured by TI.
5. User must read the user's guide and all other documentation accompanying EVMs, including without limitation any warning or restriction notices, prior to handling and/or using EVMs. Such notices contain important safety information related to, for example, temperatures and voltages. For additional information on TI's environmental and/or safety programs, please visit [www.ti.com/esh](http://www.ti.com/esh) or contact TI.
6. User assumes all responsibility, obligation, and any corresponding liability for proper and safe handling and use of EVMs.
7. Should any EVM not meet the specifications indicated in the user's guide or other documentation accompanying such EVM, the EVM may be returned to TI within 30 days from the date of delivery for a full refund. THE FOREGOING LIMITED WARRANTY IS THE EXCLUSIVE WARRANTY MADE BY TI TO USER AND IS IN LIEU OF ALL OTHER WARRANTIES, EXPRESSED, IMPLIED, OR STATUTORY, INCLUDING ANY WARRANTY OF MERCHANTABILITY OR FITNESS FOR ANY PARTICULAR PURPOSE. TI SHALL NOT BE LIABLE TO USER FOR ANY INDIRECT, SPECIAL, INCIDENTAL, OR CONSEQUENTIAL DAMAGES RELATED TO THE HANDLING OR USE OF ANY EVM.
8. No license is granted under any patent right or other intellectual property right of TI covering or relating to any machine, process, or combination in which EVMs might be or are used. TI currently deals with a variety of customers, and therefore TI's arrangement with the user is not exclusive. TI assumes no liability for applications assistance, customer product design, software performance, or infringement of patents or services with respect to the handling or use of EVMs.
9. User assumes sole responsibility to determine whether EVMs may be subject to any applicable federal, state, or local laws and regulatory requirements (including but not limited to U.S. Food and Drug Administration regulations, if applicable) related to its handling and use of EVMs and, if applicable, compliance in all respects with such laws and regulations.
10. User has sole responsibility to ensure the safety of any activities to be conducted by it and its employees, affiliates, contractors or designees, with respect to handling and using EVMs. Further, user is responsible to ensure that any interfaces (electronic and/or mechanical) between EVMs and any human body are designed with suitable isolation and means to safely limit accessible leakage currents to minimize the risk of electrical shock hazard.
11. User shall employ reasonable safeguards to ensure that user's use of EVMs will not result in any property damage, injury or death, even if EVMs should fail to perform as described or expected.
12. User shall be solely responsible for proper disposal and recycling of EVMs consistent with all applicable federal, state, and local requirements.

**Certain Instructions.** User shall operate EVMs within TI's recommended specifications and environmental considerations per the user's guide, accompanying documentation, and any other applicable requirements. Exceeding the specified ratings (including but not limited to input and output voltage, current, power, and environmental ranges) for EVMs may cause property damage, personal injury or death. If there are questions concerning these ratings, user should contact a TI field representative prior to connecting interface electronics including input power and intended loads. Any loads applied outside of the specified output range may result in unintended and/or inaccurate operation and/or possible permanent damage to the EVM and/or interface electronics. Please consult the applicable EVM user's guide prior to connecting any load to the EVM output. If there is uncertainty as to the load specification, please contact a TI field representative. During normal operation, some circuit components may have case temperatures greater than 60°C as long as the input and output are maintained at a normal ambient operating temperature. These components include but are not limited to linear regulators, switching transistors, pass transistors, and current sense resistors which can be identified using EVMs' schematics located in the applicable EVM user's guide. When placing measurement probes near EVMs during normal operation, please be aware that EVMs may become very warm. As with all electronic evaluation tools, only qualified personnel knowledgeable in electronic measurement and diagnostics normally found in development environments should use EVMs.

**Agreement to Defend, Indemnify and Hold Harmless.** User agrees to defend, indemnify, and hold TI, its directors, officers, employees, agents, representatives, affiliates, licensors and their representatives harmless from and against any and all claims, damages, losses, expenses, costs and liabilities (collectively, "Claims") arising out of, or in connection with, any handling and/or use of EVMs. User's indemnity shall apply whether Claims arise under law of tort or contract or any other legal theory, and even if EVMs fail to perform as described or expected.

**Safety-Critical or Life-Critical Applications.** If user intends to use EVMs in evaluations of safety critical applications (such as life support), and a failure of a TI product considered for purchase by user for use in user's product would reasonably be expected to cause severe personal injury or death such as devices which are classified as FDA Class III or similar classification, then user must specifically notify TI of such intent and enter into a separate Assurance and Indemnity Agreement.

## **RADIO FREQUENCY REGULATORY COMPLIANCE INFORMATION FOR EVALUATION MODULES**

Texas Instruments Incorporated (TI) evaluation boards, kits, and/or modules (EVMs) and/or accompanying hardware that is marketed, sold, or loaned to users may or may not be subject to radio frequency regulations in specific countries.

### **General Statement for EVMs Not Including a Radio**

For EVMs not including a radio and not subject to the U.S. Federal Communications Commission (FCC) or Industry Canada (IC) regulations, TI intends EVMs to be used only for engineering development, demonstration, or evaluation purposes. EVMs are not finished products typically fit for general consumer use. EVMs may nonetheless generate, use, or radiate radio frequency energy, but have not been tested for compliance with the limits of computing devices pursuant to part 15 of FCC or the ICES-003 rules. Operation of such EVMs may cause interference with radio communications, in which case the user at his own expense will be required to take whatever measures may be required to correct this interference.

### **General Statement for EVMs including a radio**

*User Power/Frequency Use Obligations:* For EVMs including a radio, the radio included in such EVMs is intended for development and/or professional use only in legally allocated frequency and power limits. Any use of radio frequencies and/or power availability in such EVMs and their development application(s) must comply with local laws governing radio spectrum allocation and power limits for such EVMs. It is the user's sole responsibility to only operate this radio in legally acceptable frequency space and within legally mandated power limitations. Any exceptions to this are strictly prohibited and unauthorized by TI unless user has obtained appropriate experimental and/or development licenses from local regulatory authorities, which is the sole responsibility of the user, including its acceptable authorization.

### **U.S. Federal Communications Commission Compliance**

#### **For EVMs Annotated as FCC – FEDERAL COMMUNICATIONS COMMISSION Part 15 Compliant**

##### **Caution**

This device complies with part 15 of the FCC Rules. Operation is subject to the following two conditions: (1) This device may not cause harmful interference, and (2) this device must accept any interference received, including interference that may cause undesired operation. Changes or modifications could void the user's authority to operate the equipment.

##### **FCC Interference Statement for Class A EVM devices**

This equipment has been tested and found to comply with the limits for a Class A digital device, pursuant to part 15 of the FCC Rules. These limits are designed to provide reasonable protection against harmful interference when the equipment is operated in a commercial environment. This equipment generates, uses, and can radiate radio frequency energy and, if not installed and used in accordance with the instruction manual, may cause harmful interference to radio communications. Operation of this equipment in a residential area is likely to cause harmful interference in which case the user will be required to correct the interference at its own expense.

##### **FCC Interference Statement for Class B EVM devices**

This equipment has been tested and found to comply with the limits for a Class B digital device, pursuant to part 15 of the FCC Rules. These limits are designed to provide reasonable protection against harmful interference in a residential installation. This equipment generates, uses and can radiate radio frequency energy and, if not installed and used in accordance with the instructions, may cause harmful interference to radio communications. However, there is no guarantee that interference will not occur in a particular installation. If this equipment does cause harmful interference to radio or television reception, which can be determined by turning the equipment off and on, the user is encouraged to try to correct the interference by one or more of the following measures:

- Reorient or relocate the receiving antenna.
- Increase the separation between the equipment and receiver.
- Connect the equipment into an outlet on a circuit different from that to which the receiver is connected.
- Consult the dealer or an experienced radio/TV technician for help.

##### **Industry Canada Compliance (English)**

#### **For EVMs Annotated as IC – INDUSTRY CANADA Compliant:**

This Class A or B digital apparatus complies with Canadian ICES-003.

Changes or modifications not expressly approved by the party responsible for compliance could void the user's authority to operate the equipment.

##### **Concerning EVMs Including Radio Transmitters**

This device complies with Industry Canada licence-exempt RSS standard(s). Operation is subject to the following two conditions: (1) this device may not cause interference, and (2) this device must accept any interference, including interference that may cause undesired operation of the device.

##### **Concerning EVMs Including Detachable Antennas**

Under Industry Canada regulations, this radio transmitter may only operate using an antenna of a type and maximum (or lesser) gain approved for the transmitter by Industry Canada. To reduce potential radio interference to other users, the antenna type and its gain should be so chosen that the equivalent isotropically radiated power (e.i.r.p.) is not more than that necessary for successful communication.

This radio transmitter has been approved by Industry Canada to operate with the antenna types listed in the user guide with the maximum permissible gain and required antenna impedance for each antenna type indicated. Antenna types not included in this list, having a gain greater than the maximum gain indicated for that type, are strictly prohibited for use with this device.

## Canada Industry Canada Compliance (French)

Cet appareil numérique de la classe A ou B est conforme à la norme NMB-003 du Canada

Les changements ou les modifications pas expressément approuvés par la partie responsable de la conformité ont pu vider l'autorité de l'utilisateur pour actionner l'équipement.

### Concernant les EVMs avec appareils radio

Le présent appareil est conforme aux CNR d'Industrie Canada applicables aux appareils radio exempts de licence. L'exploitation est autorisée aux deux conditions suivantes : (1) l'appareil ne doit pas produire de brouillage, et (2) l'utilisateur de l'appareil doit accepter tout brouillage radioélectrique subi, même si le brouillage est susceptible d'en compromettre le fonctionnement.

### Concernant les EVMs avec antennes détachables

Conformément à la réglementation d'Industrie Canada, le présent émetteur radio peut fonctionner avec une antenne d'un type et d'un gain maximal (ou inférieur) approuvé pour l'émetteur par Industrie Canada. Dans le but de réduire les risques de brouillage radioélectrique à l'intention des autres utilisateurs, il faut choisir le type d'antenne et son gain de sorte que la puissance isotrope rayonnée équivalente (p.i.r.e.) ne dépasse pas l'intensité nécessaire à l'établissement d'une communication satisfaisante.

Le présent émetteur radio a été approuvé par Industrie Canada pour fonctionner avec les types d'antenne énumérés dans le manuel d'usage et ayant un gain admissible maximal et l'impédance requise pour chaque type d'antenne. Les types d'antenne non inclus dans cette liste, ou dont le gain est supérieur au gain maximal indiqué, sont strictement interdits pour l'exploitation de l'émetteur.

Mailing Address: Texas Instruments, Post Office Box 655303, Dallas, Texas 75265  
Copyright © 2014, Texas Instruments Incorporated

## Important Notice for Users of EVMs Considered “Radio Frequency Products” in Japan

### EVMs entering Japan are NOT certified by TI as conforming to Technical Regulations of Radio Law of Japan.

If user uses EVMs in Japan, user is required by Radio Law of Japan to follow the instructions below with respect to EVMs:

1. Use EVMs in a shielded room or any other test facility as defined in the notification #173 issued by Ministry of Internal Affairs and Communications on March 28, 2006, based on Sub-section 1.1 of Article 6 of the Ministry's Rule for Enforcement of Radio Law of Japan,
2. Use EVMs only after user obtains the license of Test Radio Station as provided in Radio Law of Japan with respect to EVMs, or
3. Use of EVMs only after user obtains the Technical Regulations Conformity Certification as provided in Radio Law of Japan with respect to EVMs. Also, do not transfer EVMs, unless user gives the same notice above to the transferee. Please note that if user does not follow the instructions above, user will be subject to penalties of Radio Law of Japan.

<http://www.tij.co.jp>

【無線電波を送信する製品の開発キットをお使いになる際の注意事項】本開発キットは技術基準適合証明を受けておりません。本製品のご使用に際しては、電波法遵守のため、以下のいずれかの措置を取っていただく必要がありますのでご注意ください。

1. 電波法施行規則第6条第1項第1号に基づく平成18年3月28日総務省告示第173号で定められた電波暗室等の試験設備でご使用いただく。
2. 実験局の免許を取得後ご使用いただく。
3. 技術基準適合証明を取得後ご使用いただく。。

なお、本製品は、上記の「ご使用にあたっての注意」を譲渡先、移転先に通知しない限り、譲渡、移転できないものとします

上記を遵守頂けない場合は、電波法の罰則が適用される可能性があることをご留意ください。

日本テキサス・インスツルメンツ株式会社

東京都新宿区西新宿6丁目24番1号

西新宿三井ビル

<http://www.tij.co.jp>

Texas Instruments Japan Limited

(address) 24-1, Nishi-Shinjuku 6 chome, Shinjuku-ku, Tokyo, Japan

## IMPORTANT NOTICE

Texas Instruments Incorporated and its subsidiaries (TI) reserve the right to make corrections, enhancements, improvements and other changes to its semiconductor products and services per JESD46, latest issue, and to discontinue any product or service per JESD48, latest issue. Buyers should obtain the latest relevant information before placing orders and should verify that such information is current and complete. All semiconductor products (also referred to herein as "components") are sold subject to TI's terms and conditions of sale supplied at the time of order acknowledgment.

TI warrants performance of its components to the specifications applicable at the time of sale, in accordance with the warranty in TI's terms and conditions of sale of semiconductor products. Testing and other quality control techniques are used to the extent TI deems necessary to support this warranty. Except where mandated by applicable law, testing of all parameters of each component is not necessarily performed.

TI assumes no liability for applications assistance or the design of Buyers' products. Buyers are responsible for their products and applications using TI components. To minimize the risks associated with Buyers' products and applications, Buyers should provide adequate design and operating safeguards.

TI does not warrant or represent that any license, either express or implied, is granted under any patent right, copyright, mask work right, or other intellectual property right relating to any combination, machine, or process in which TI components or services are used. Information published by TI regarding third-party products or services does not constitute a license to use such products or services or a warranty or endorsement thereof. Use of such information may require a license from a third party under the patents or other intellectual property of the third party, or a license from TI under the patents or other intellectual property of TI.

Reproduction of significant portions of TI information in TI data books or data sheets is permissible only if reproduction is without alteration and is accompanied by all associated warranties, conditions, limitations, and notices. TI is not responsible or liable for such altered documentation. Information of third parties may be subject to additional restrictions.

Resale of TI components or services with statements different from or beyond the parameters stated by TI for that component or service voids all express and any implied warranties for the associated TI component or service and is an unfair and deceptive business practice. TI is not responsible or liable for any such statements.

Buyer acknowledges and agrees that it is solely responsible for compliance with all legal, regulatory and safety-related requirements concerning its products, and any use of TI components in its applications, notwithstanding any applications-related information or support that may be provided by TI. Buyer represents and agrees that it has all the necessary expertise to create and implement safeguards which anticipate dangerous consequences of failures, monitor failures and their consequences, lessen the likelihood of failures that might cause harm and take appropriate remedial actions. Buyer will fully indemnify TI and its representatives against any damages arising out of the use of any TI components in safety-critical applications.

In some cases, TI components may be promoted specifically to facilitate safety-related applications. With such components, TI's goal is to help enable customers to design and create their own end-product solutions that meet applicable functional safety standards and requirements. Nonetheless, such components are subject to these terms.

No TI components are authorized for use in FDA Class III (or similar life-critical medical equipment) unless authorized officers of the parties have executed a special agreement specifically governing such use.

Only those TI components which TI has specifically designated as military grade or "enhanced plastic" are designed and intended for use in military/aerospace applications or environments. Buyer acknowledges and agrees that any military or aerospace use of TI components which have **not** been so designated is solely at the Buyer's risk, and that Buyer is solely responsible for compliance with all legal and regulatory requirements in connection with such use.

TI has specifically designated certain components as meeting ISO/TS16949 requirements, mainly for automotive use. In any case of use of non-designated products, TI will not be responsible for any failure to meet ISO/TS16949.

### Products

Audio	<a href="http://www.ti.com/audio">www.ti.com/audio</a>
Amplifiers	<a href="http://amplifier.ti.com">amplifier.ti.com</a>
Data Converters	<a href="http://dataconverter.ti.com">dataconverter.ti.com</a>
DLP® Products	<a href="http://www.dlp.com">www.dlp.com</a>
DSP	<a href="http://dsp.ti.com">dsp.ti.com</a>
Clocks and Timers	<a href="http://www.ti.com/clocks">www.ti.com/clocks</a>
Interface	<a href="http://interface.ti.com">interface.ti.com</a>
Logic	<a href="http://logic.ti.com">logic.ti.com</a>
Power Mgmt	<a href="http://power.ti.com">power.ti.com</a>
Microcontrollers	<a href="http://microcontroller.ti.com">microcontroller.ti.com</a>
RFID	<a href="http://www.ti-rfid.com">www.ti-rfid.com</a>
OMAP Applications Processors	<a href="http://www.ti.com/omap">www.ti.com/omap</a>
Wireless Connectivity	<a href="http://www.ti.com/wirelessconnectivity">www.ti.com/wirelessconnectivity</a>

### Applications

Automotive and Transportation	<a href="http://www.ti.com/automotive">www.ti.com/automotive</a>
Communications and Telecom	<a href="http://www.ti.com/communications">www.ti.com/communications</a>
Computers and Peripherals	<a href="http://www.ti.com/computers">www.ti.com/computers</a>
Consumer Electronics	<a href="http://www.ti.com/consumer-apps">www.ti.com/consumer-apps</a>
Energy and Lighting	<a href="http://www.ti.com/energy">www.ti.com/energy</a>
Industrial	<a href="http://www.ti.com/industrial">www.ti.com/industrial</a>
Medical	<a href="http://www.ti.com/medical">www.ti.com/medical</a>
Security	<a href="http://www.ti.com/security">www.ti.com/security</a>
Space, Avionics and Defense	<a href="http://www.ti.com/space-avionics-defense">www.ti.com/space-avionics-defense</a>
Video and Imaging	<a href="http://www.ti.com/video">www.ti.com/video</a>

### TI E2E Community

[e2e.ti.com](http://e2e.ti.com)