

Series 2000 Reader System

***Control Modules RI-CTL-MB2B
RI-CTL-MB6B***

Reference Guide

January 2008



SCBU044 (11-09-21-077)

Series 2000 Reader System

***Control Modules RI-CTL-MB2B
RI-CTL-MB6B***

Reference Guide



Literature Number: SCBU044 (11-09-21-077)

January 2008



Preface	7
1 Introduction	9
1.1 General	10
1.2 Product Description	11
1.3 Associated RFMs.....	11
2 Installation	13
2.1 General	14
2.2 Mechanical Installation	14
2.3 Electrical Installation	14
2.3.1 Connectors	15
2.4 Software Configuration	18
2.5 Power Supplies	19
2.5.1 Common DC Power Supply for Both Control and RF Modules	19
2.5.2 Non-Regulated DC Power Supply (Without Memory Backup)	20
2.5.3 Regulated DC Power Supply (Without Memory Battery Backup)	20
2.5.4 Battery Backup for Memory	20
2.6 Service/Configuration Interface.....	21
2.7 Serial Communication Interface	21
2.7.1 Interface Configuration	22
2.7.2 RS-232-C Interface	22
2.7.3 RS-422/485 Interface	22
2.8 Synchronization Interface	25
2.8.1 Synchronization Interface	25
2.8.2 Wired and Combined Wireless/Wired Synchronization	26
2.8.3 Master/ Slave Synchronization without Acknowledgement; Triggered Synchronization without Acknowledgement	26
2.8.4 Master/Slave Synchronization With Acknowledgement	27
2.9 Input/Reset	28
2.10 Indicator Outputs	29
2.11 RFM RXSS Tuning Inputs.....	29
2.12 General Purpose I/O	30
2.13 Open Collector Outputs	31
3 Specifications	33
3.1 General Data.....	34
3.1.1 Mechanical Dimensions	34
3.1.2 Temperature	35
3.2 Electrical Data	35
3.2.1 Recommended Operating Conditions, Electrical Characteristics	35
4 Terms and Abbreviations	39

List of Figures

1-1	Series 2000 Control Module	10
2-1	Bottom View of Series 2000 Control Board.....	14
2-2	Detailed View of Jumpers JP1 – JP5.....	15
2-3	Detailed View of Dip-Switch S1	15
2-4	Single Power Supply for Both Control and RF Modules	19
2-5	Non-Regulated Power Supply	20
2-6	5V Regulated Control-Logic Power Supply	20
2-7	Battery Backup for Memory	21
2-8	USB Interface	21
2-9	RS-232 9-Pin Interface Connection.....	22
2-10	RS-422/RS-485 Interface Circuitry.....	23
2-11	RS-422 Interface Connection.....	23
2-12	RS-485 Interface Connection.....	24
2-13	Synchronization Interface Circuitry.....	25
2-14	Synchronization Interface Connector	25
2-15	Wired and/or Combined Wireless/Wired Synchronization	26
2-16	Synchronization Interface Connection.....	27
2-17	Master/Slave Synchronization With Acknowledgment	28
2-18	Input/Reset Connection.....	28
2-19	Indicator Outputs	29
2-20	RFM Tuning Inputs.....	29
2-21	General Purpose I/O Port Pin Assignment.....	30
2-22	Open Collector Outputs	31
3-1	Mechanical Dimensions	34

List of Tables

1-1	Associated RFMs.....	11
2-1	ST21 – RS-232 Communication Interface (RI-CTL-MB2B).....	15
2-2	ST21 – RS-422 Communication Interface (RI-CTL-MB6B).....	16
2-3	ST21 – RS-485 Communication Interface (RI-CTL-MB6B).....	16
2-4	ST22 – Supply	16
2-5	ST23 – Mini-USB B Interface	16
2-6	ST24 – Synchronization Interface.....	16
2-7	ST31 – RXSS Inputs.....	17
2-8	ST32 – Indicator Outputs.....	17
2-9	ST33 – Input/Reset	17
2-10	ST34 – Input/Output Port 4 – 7.....	17
2-11	ST35 – Input/Output Port 0 – 3.....	17
2-12	ST36 – Open Collector Outputs	17
2-13	Wired and Combined Wireless/Wired Synchronization	26
2-14	Master/Slave Synchronization without Acknowledgement	27
2-15	Triggered Synchronization without Acknowledgement	27
2-16	Master/Slave Synchronization With Acknowledgement	28

Edition 001 – January 2008

This is the first edition of this Guide and describes the following Series 2000 Control Modules:

RI-CTL-MB2B Control Module with RS-232 interface

RI-CTL-MB6B Control Module with RS-422/485 interface

Both modules contain Firmware S2000 – REV 1.00

Texas Instruments (TI) reserves the right to make changes to its products or services or to discontinue any product or service at any time without notice. TI provides customer assistance in various technical areas, but does not have full access to data concerning the use and applications of customers' products.

Therefore, TI assumes no liability and is not responsible for Customer applications or product or software design or performance relating to systems or applications incorporating TI products. In addition, TI assumes no liability and is not responsible for infringement of patents and/or any other intellectual or industrial property rights of third parties, which may result from assistance provided by TI.

TI products are not designed, intended, authorized or warranted to be suitable for life support applications or any other life critical applications which could involve potential risk of death, personal injury, or severe property or environmental damage.

The TI-RFID logo, the words TI-RFID™ and Tag-it™ are trademarks or registered trademarks of Texas Instruments Incorporated (TI).

Copyright (C) 2008 Texas Instruments Incorporated (TI)

This document may be downloaded onto a computer, stored and duplicated as necessary to support the use of the related TI products. Any other type of duplication, circulation or storage on data carriers in any manner not authorized by TI represents a violation of the applicable copyright laws and shall be prosecuted.

About This Guide

This manual describes the Texas Instruments Series 2000 Control Modules RI-CTL-MB2B and RI-CTL-MB6B. It describes the modules themselves, how to install them and how to use them.

Conventions

WARNING

A warning is used where care must be taken or a certain procedure must be followed, in order to prevent injury or harm to your health.

CAUTION

This indicates information on conditions, which must be met, or a procedure, which must be followed, which if not heeded could cause permanent damage to the system.

Note: Indicates conditions, which must be met, or procedures, which must be followed, to ensure proper functioning of any hardware or software.

If You Need Assistance

For more information, please contact the sales office or distributor nearest you. This contact information can be found on our web site at: <http://www.ti-rfid.com>.

Introduction

The Chapter will introduce you to the Control Module and the products with which it works.

Topic	Page
1.1 General	10
1.2 Product Description	11
1.3 Associated RFMs	11

1.1 General

This document provides information about how to install the Texas Instruments Series 2000 Control Module. It also provides specifications of all the inputs and outputs of the following S2000 Control Modules:

RI-CTL-MB2B and RI-CTL-MB6B



Figure 1-1. Series 2000 Control Module

1.2 Product Description

The Series 2000 Control is the interface between a Texas Instruments' Radio Frequency Module (RFM) and a controlling host. It controls the transmit and receive functions of the RFM according to the commands from the host to send signals and to receive data from a transponder. It decodes the received RF signals into the transponder's identification number, checks the validity, and handles the protocol conversion to a standard serial interface.

The Control Module is offered with two different interfaces:

- RI-CTL-MB2B for point-to-point communication via an RS-232 interface
- RI-CTL-MB6B for point-to-point via an RS-422 interface or point-to-multipoint communications via an RS-422/485 interface.

There are two communications protocols available:

- TIRIS Bus Protocol (TBP) that can be used with point-to-point or point-to-multipoint systems
- ASCII Protocol for use with point-to-point systems.

For details regarding the communications protocol (ASCII or TBP) please refer to the ASCII Protocol and TBP Reference Guides which are available at Texas Instruments' RFID internet site: www.ti-rfid.com.

The Control Module can be configured via the USB or standard serial interface according to applicable specific requirements.

The Control Module has eight configurable digital input/outputs that can be defined by the user and two open collector outputs. It also includes a wireless synchronization feature and a port to allow wired synchronization to avoid interference between readers located close to each other.

Four indication LEDs show the status of the module.

1.3 Associated RFMs

The S2000 Control Module works together with the Radio Frequency Modules listed in [Table 1-1](#).

Table 1-1. Associated RFMs

RFM Type	Number	Reference Guide Number
High Performance RFM	RI-RFM-007B	11-06-21-042
High Performance RA-RFM	RI-RFM-008B	11-06-21-047

The RFM Reference Guides listed in [Table 1-1](#) can be found on Texas Instrument's website at www.ti-rfid.com.

Installation

The Chapter provides information about how to install the Series 2000 Control Module and set all the various switches and jumpers according to the system within which it is located.

Topic	Page
2.1 General	14
2.2 Mechanical Installation	14
2.3 Electrical Installation	14
2.3.1 Connectors	15
2.4 Software Configuration	18
2.5 Power Supplies	19
2.5.1 Common DC Power Supply for Both Control and RF Modules	19
2.5.2 Non-Regulated DC Power Supply (Without Memory Backup)	20
2.5.3 Regulated DC Power Supply (Without Memory Battery Backup)	20
2.5.4 Battery Backup for Memory	20
2.6 Service/Configuration Interface	21
2.7 Serial Communication Interface	21
2.7.1 Interface Configuration	22
2.7.2 RS-232-C Interface	22
2.7.3 RS-422/485 Interface	22
2.8 Synchronization Interface	25
2.8.1 Synchronization Interface	25
2.8.2 Wired and Combined Wireless/Wired Synchronization	26
2.8.3 Master/ Slave Synchronization without Acknowledgement; Triggered Synchronization without Acknowledgement	26
2.8.4 Master/Slave Synchronization With Acknowledgement	27
2.9 Input/Reset	28
2.10 Indicator Outputs	29
2.11 RFM RXSS Tuning Inputs	29
2.12 General Purpose I/O	30
2.13 Open Collector Outputs	31

2.1 General

CAUTION

Handle your S2000 Control Module only according to ESD handling requirements!

Since the human body can be charged up to thousands of volts (electrostatic charge) you should not touch any part or connector of the Control Module without taking appropriate precautions.

2.2 Mechanical Installation

Mount the RFM on top of the Control Module using four M3 hexagon spacing bolts so that the connector for the supply voltages and interface signal lines from the Control Module (ST4) with its counterpart on the RFM. Both High Performance RFMs require 2-mm spacers and 10-mm screws.

2.3 Electrical Installation

The Series 2000 Control Module has 10 plug and screw connectors which provide all connections necessary for supply and control (see [Figure 2-1](#)). The connections are given in Section 2.3.1.

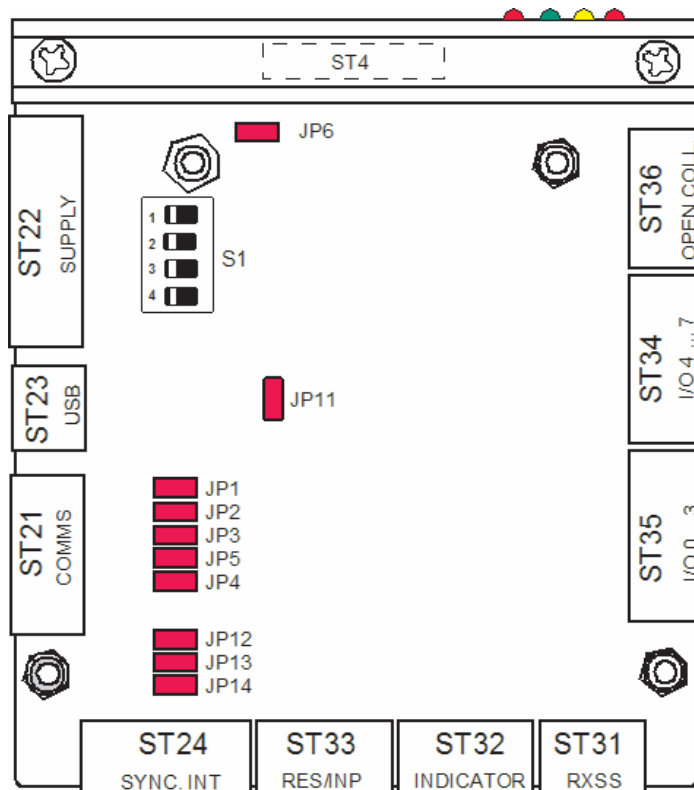

Figure 2-1. Bottom View of Series 2000 Control Board

Note: ST4 is the RFM connector and is accessible from the top.

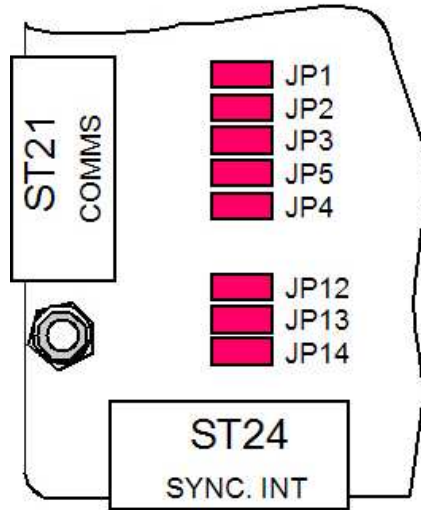

Figure 2-2. Detailed View of Jumpers JP1 – JP5

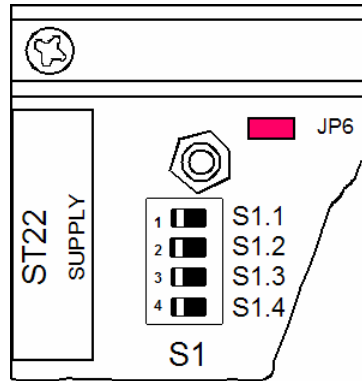

Figure 2-3. Detailed View of Dip-Switch S1

2.3.1 Connectors

Please refer to Section 3.2.1 "Recommended Operating Conditions, Electrical Characteristics" for electrical details and limits for all these connectors.

CAUTION

Always "power down" before connecting or disconnecting any of the cables.

Table 2-1. ST21 – RS-232 Communication Interface (RI-CTL-MB2B)

Signal Name	Pin	Comment
RXD	1	RS-232-C Serial Data Input
DTR	2	RS-232-C Data Terminal Ready Input
GND	3	Signal Ground
TXD	4	RS-232-C Serial Data Output
DSR	5	RS-232-C Data Set Ready Output

Table 2-2. ST21 – RS-422 Communication Interface (RI-CTL-MB6B)

Signal Name	Pin	Comment
RX+	1	RS-422 Non-inverted Data Input
RX–	2	RS-422 Inverted Data Input
GND	3	Signal Ground
TX+	4	RS-422 Non-inverted Data Output
TX–	5	RS-422 Inverted Data Output

Table 2-3. ST21 – RS-485 Communication Interface (RI-CTL-MB6B)

Signal Name	Pin	Comment
TX+/RX+	1	RS-485 Non-inverted Data Output/ Input
TX–/RX–	2	RS-485 Inverted Data Output/ Input
GND	3	Signal Ground

Table 2-4. ST22 – Supply

Signal Name	Pin	Comment
VSP	1	Supply voltage for the RF Module
GNDP	2	Ground line for the RF Module supply.
VDC	3	Non-regulated supply voltage for the control logic circuitry.
GND	4	Signal ground line for the control logic supply.
VCC2	5	Regulated supply voltage (5VDC) for the control logic circuitry.
VCC3	6	Memory data retention supply voltage
GND	7	Signal ground

Table 2-5. ST23 – Mini-USB B Interface

Signal Name	Pin	Comment
VCC	1	+5 VDC
DM	2	Data –
DP	3	Data +
	4	Not connected
GND	5	Ground

The red LED (furthest from the edge) will be lit to indicate that a USB Cable is connecting the Control Module to a host computer and is powered.

Table 2-6. ST24 – Synchronization Interface

Signal Name	Pin	Comment
SYNC. RX+	1	RS-422/485 Non-inverted Data Input
SYNC. RX–	2	RS-422/485 Inverted Data Input
GND	3	Signal Ground
SYNC. TX+	4	RS-422/485 Non-inverted Data Output
SYNC. TX–	5	RS-422/485 Inverted Data Output

Table 2-7. ST31 – RXSS Inputs

Signal Name	Pin	Comment
RSCA/RXSA1	1	RSCA/RXSA1 Receiver Signal Strength Control A Receiver Signal Strength Adjust refer to RFM Manual
RSCB	2	Receiver Signal Strength Control B (not used)
GND	3	Signal Ground

Table 2-8. ST32 – Indicator Outputs

Signal Name	Pin	Comment
VCC2	1	Regulated 5 VDC supply output
ACTIVE–	2	Open Collector Output: RF Module Transmitter Signal
OK–	3	Open Collector Output: OK Signal
EMI–	4	Open Collector Output: EMI Signal

Table 2-9. ST33 – Input/Reset

Signal Name	Pin	Comment
IN0	1	General Purpose Input 0
IN1	2	General Purpose Input 1
RESET	3	RESET Input/Output
GND	4	Signal Ground

Table 2-10. ST34 – Input/Output Port 4 – 7

Signal Name	Pin	Comment
I/O 4	1	General Purpose Input/Output 4
I/O 5	2	General Purpose Input/Output 5
I/O 6	3	General Purpose Input/Output 6
I/O 7	4	General Purpose Input/Output 7
GND	5	Signal Ground

Table 2-11. ST35 – Input/Output Port 0 – 3

Signal Name	Pin	Comment
I/O 0	1	General Purpose Input/Output 0
I/O 1	2	General Purpose Input/Output 1
I/O 2	3	General Purpose Input/Output 2
I/O 3	4	General Purpose Input/Output 3
GND	5	Signal Ground

Table 2-12. ST36 – Open Collector Outputs

Signal Name	Pin	Comment
VCC2	1	Regulated 5 VDC Supply Output
OC0	2	Open Collector Output 0
OC1	3	Open Collector Output 1
GND	4	Signal Ground

2.4 Software Configuration

The Texas Instruments utility "S2_Util.exe", which is available at www.ti-rfid.com, can be used to configure the Series 2000 Control Module according to the customers application specific requirements concerning:

- Communication protocol
- Communication parameters
- Default read mode
- RF Module parameters
- Synchronization type
- Default I/O settings

Dip-switch S1 (S1.1) determines the mode of operation of the Control Module. If Dip-switch S1.1 is in the OFF position, standard default parameters are used. These are:

- RI-CTL-MB2B
 - ASCII protocol
 - 9600 baud, eight databits, no parity, one stop bit, Xon/Xoff enabled
 - Normal mode
 - RF module power RFM-007 (also valid for RFM-008)
 - Wireless synchronization
 - I/O 0 to 3 defined as input
 - I/O 4 to 7 defined as output and logic high
 - Hardware interface RS-232
- RI-CTL-MB6B
 - ASCII protocol
 - 9600 baud, eight databits, no parity, one stop bit, Xon/Xoff enabled
 - Normal mode
 - RF module power RFM-007 (also valid for RFM-008)
 - Wireless synchronization
 - I/O 0 to 3 defined as input
 - I/O 4 to 7 defined as output and logic high
 - Hardware interface RS-422

If Dip-switch S1.1 is in the ON position, customer specific default parameters are used to operate the Control Module. These application specific parameters are stored in serial EEPROM on the Control Module.

Note: Dip-Switch S1.1 is checked at power-up, after a software RESET and during operation. Configuration changes will become active as soon as the switch is moved.

To enable the customer specific parameters to be changed the Control Module can be configured either via a communications port or via the USB service port. Connect one of these ports to the Host and get connection using the standard reader settings by switching S1.1 to the OFF position. Change the default parameters to customer parameters and save them. Then after moving Dip-switch S1.1 to the ON position, the Control Module will work with the customer specific parameters.

For details regarding the communication protocol (ASCII or TBP), please refer to the ASCII Protocol or TIRIS Bus Protocol Reference Guides which are available at Texas Instruments' RFID internet site: www.ti-rfid.com.

2.5 Power Supplies

In this section we describe the various Power Supply possibilities for the Series 2000 Control Module. These are:

- The Series 2000 Control Module and RF Module are both powered by a regulated Power Supply (see Section 2.5.1).
- The Control Module and the RF Module logic circuitry are powered by a non-regulated Power Supply, and the RF module power circuits are separately supplied by a regulated Power Supply (see Section 2.5.2).
- The Control Module and the RF Module logic circuitry are powered by a regulated (5 V) Power Supply, and the RF Module power circuits are separately supplied by a regulated Power Supply (see Section 2.5.3).

When the Series 2000 Control Module control logic circuitry is powered by an external regulated (5 V) Power Supply, Jumper JP6 must be left out.

CAUTION

The supply voltage range that can be used depends on the RFM used, therefore in all cases, refer to section 3.2.1 Recommended Operating Conditions. Electrical Characteristics for minimum, nominal and maximum input supply levels. For RFM power supply requirements please refer to the relevant RFM Reference Guide.

CAUTION

Please be very careful to ensure that you use the correct polarity in all of these methods of Power Supply as there is no reverse polarity protection built into the Control Module.

2.5.1 Common DC Power Supply for Both Control and RF Modules

Figure 2-4 shows how to connect a regulated power supply for both the Control Module and the RFM. Jumper JP6 must be closed.

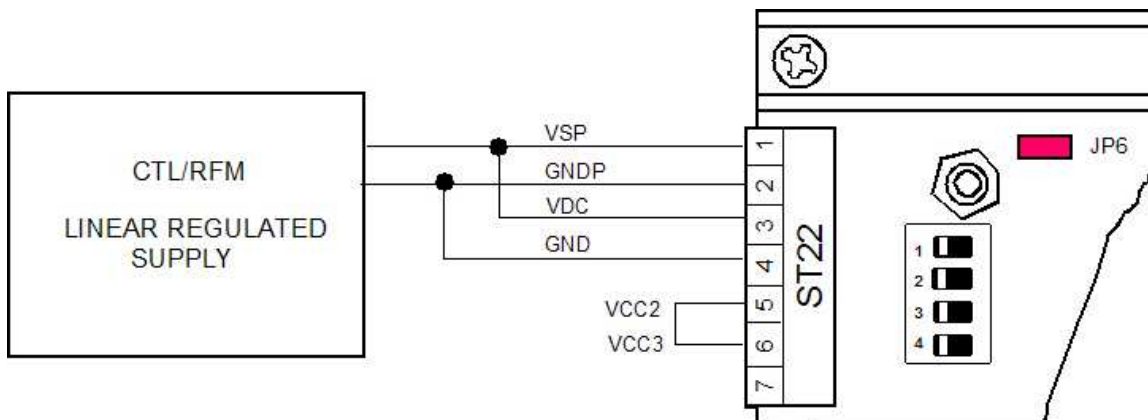

Figure 2-4. Single Power Supply for Both Control and RF Modules

2.5.2 Non-Regulated DC Power Supply (Without Memory Backup)

If a non-regulated DC Power Supply is used to supply the Control Module logic circuits, it should be connected to the reader as shown in [Figure 2-5](#). Jumper JP6 must be closed.

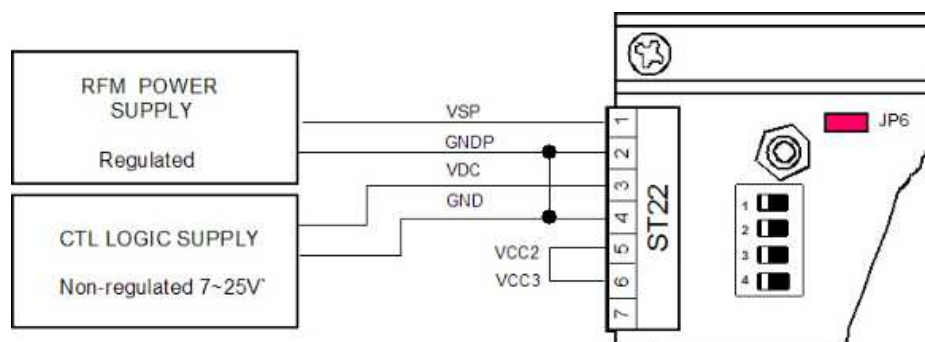

Figure 2-5. Non-Regulated Power Supply

2.5.3 Regulated DC Power Supply (Without Memory Battery Backup)

If you use a regulated (5 V) Power Supply for VCC2, it should be connected to the reader as shown in [Figure 2-6](#). Jumper JP6 must be removed.

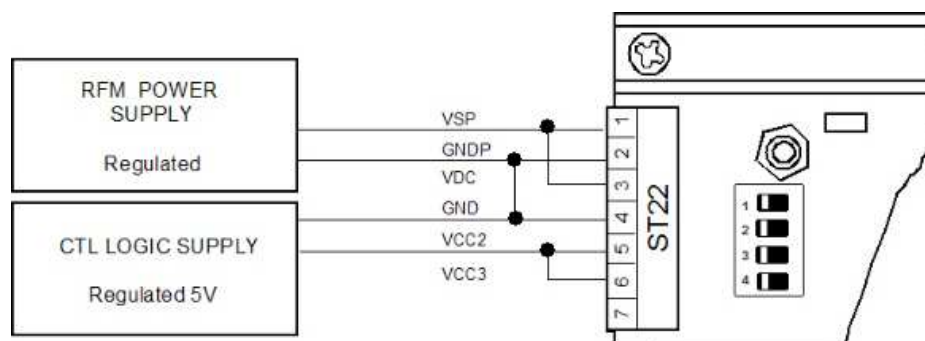

Figure 2-6. 5V Regulated Control-Logic Power Supply

2.5.4 Battery Backup for Memory

Even though the Series 2000 Control Module remains powered, it is possible the memory contents may be erased when the Control Module is reset. This occurs when power is temporarily removed from the RAM during reset.

A reset can be initiated in one of three ways:

- Internally by the reset/watchdog circuit
- Externally by using the reset input (pin 3 of ST33)
- Externally by the RS-232 DTR signal (RI-CTL-MB2B version only)

In order to prevent memory contents being lost during a reset, we recommend that the following precautions are taken:

- Connect VCC2 (pin 5 of ST22) and VCC3 (pin 6 of ST22) to each other.

In order to prevent memory contents being lost during a power-down, or during a reset, we recommend that you take the following precautions:

- Connect a battery (with VCC3 nominally 3.0 V) between pins 6 (+) and 7 (–) of ST22 as shown in [Figure 2-7](#), instead of a bridge between VCC2 and VCC3. Tolerances for the battery are given in Section 3.2.1.1.

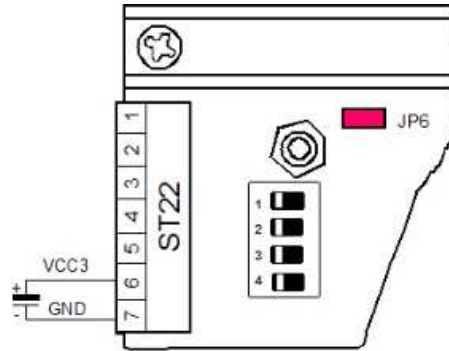

Figure 2-7. Battery Backup for Memory

2.6 Service/Configuration Interface

The Service/Configuration Interface allows both RI-CTL-MB2B and RI-CTL-MB6B to be configured via a USB serial port. A mini-USB B to USB A cable will be required for most connections.

For USB operation jumper, JP11 must be in place.

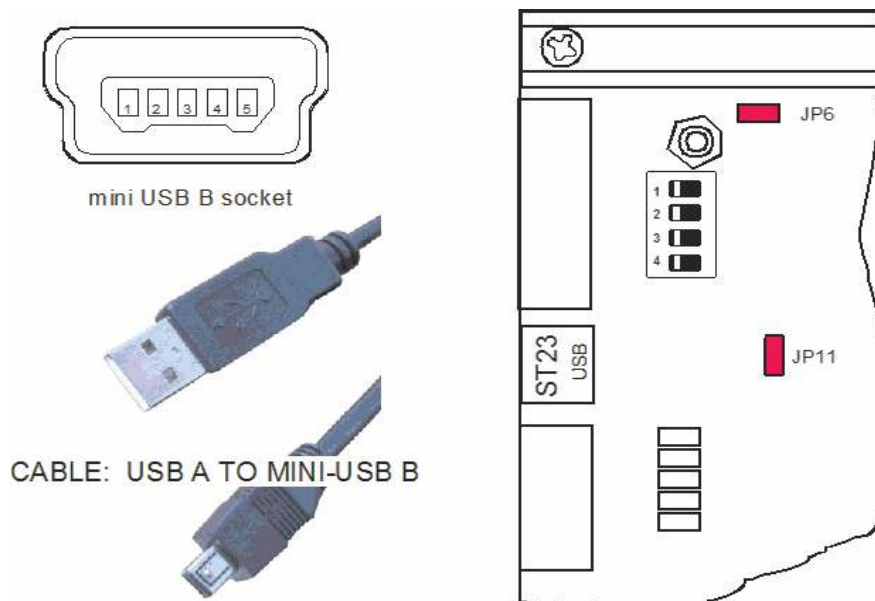

Figure 2-8. USB Interface

2.7 Serial Communication Interface

A host (usually a PC) is needed to control the Series 2000 Control module. The computer can either be situated at the reader site, or it can be at a remote location.

If the distance between the reader and the computer is less than 20 m, the RS-232 version of the Control Module (RI-CTL-MB2B) can be used; if it is further away the RS-422 or RS-485 version (RI-CTL-MB6B) should be used.

2.7.1 Interface Configuration

The Control Module firmware uses the following configuration:

Start/Stop bit

X_{ON} / X_{OFF} $X_{ON} = 17_{OEC}$; $X_{OFF} = 19_{DEC}$

The Data Rate, Parity, Data bits and Handshake can be configured using the S2_Util as described in Section 2.4.

2.7.2 RS-232-C Interface

The recommendation for connection to a 9-pin sub-D interface connector is given in Figure 2-9.

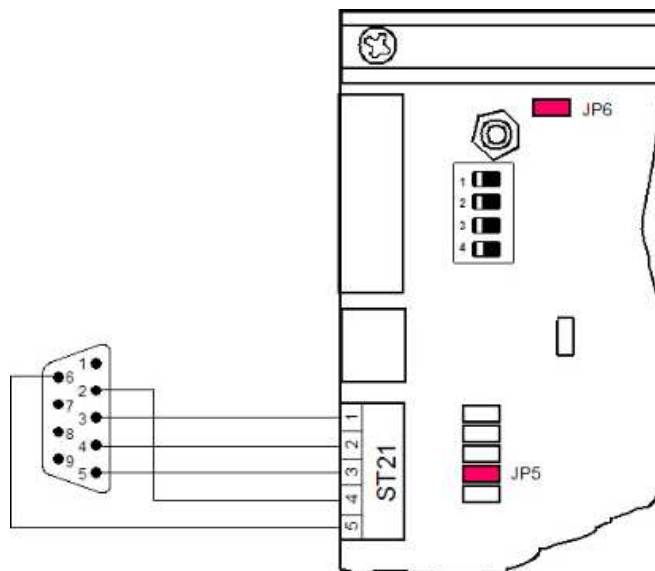

Figure 2-9. RS-232 9-Pin Interface Connection

2.7.2.1 Activation (RI-CTL-MB2B)

The Data Terminal Ready (DTR) signal is connected to the reset/watchdog circuit of the Control Module. This ensures a PC controlled microcomputer initialization before the default Read Mode is started.

If you want to run the Control module in a 3-wire connection (RXD, TXD, and GND), without remote controlled activation, Jumper 5 (JP5) must be closed. This connects DSR and DTR together.

When power is applied to the Control Module the Data Set Ready (DSR) of the RS-232, interface is activated.

2.7.3 RS-422/485 Interface

Figure 2-10 shows the circuitry of the RS-422/485 Interface. Jumper 2 (JP2) must be closed to provide line-to-line termination. If the PC is at one end of the line, it must be terminated at its RX+/RX- Inputs. The reader at the end of the line must be terminated. If the PC is connected somewhere in the middle of the line, then the readers at either end must be terminated.

Jumper JP4 and JP5 determine which of the two interface types is selected (RS-422 or RS-485). This is explained in detail in sections 2.7.3.1 and 2.7.3.2.

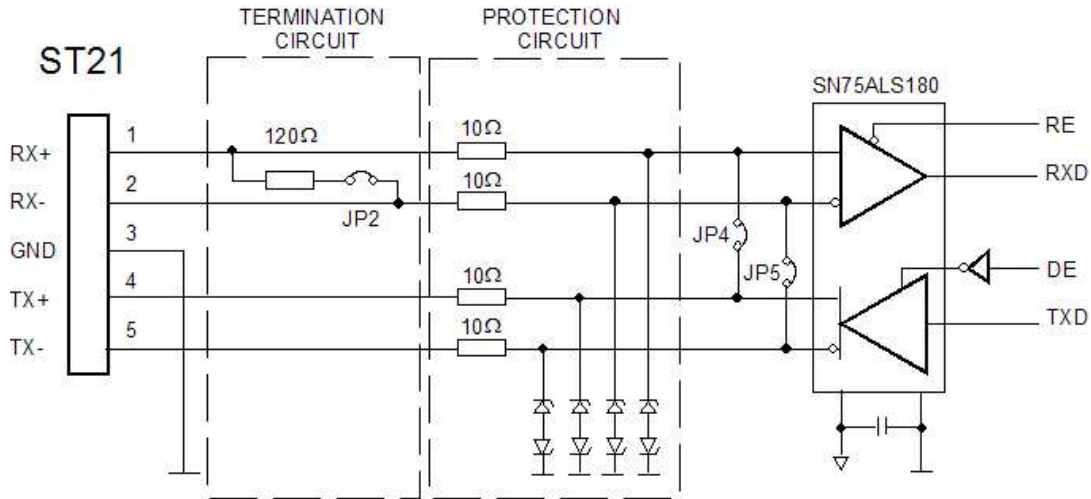

Figure 2-10. RS-422/RS-485 Interface Circuitry

2.7.3.1 RS-422 Interface

Recommendations for point-to-point RS-422 interface connection are given in [Figure 2-11](#). In this case, Jumper 2 (JP2) must be closed. Jumpers JP4 and JP5 must be open. For multi-point RS-422 communications, only the reader at the end of the line must be terminated.

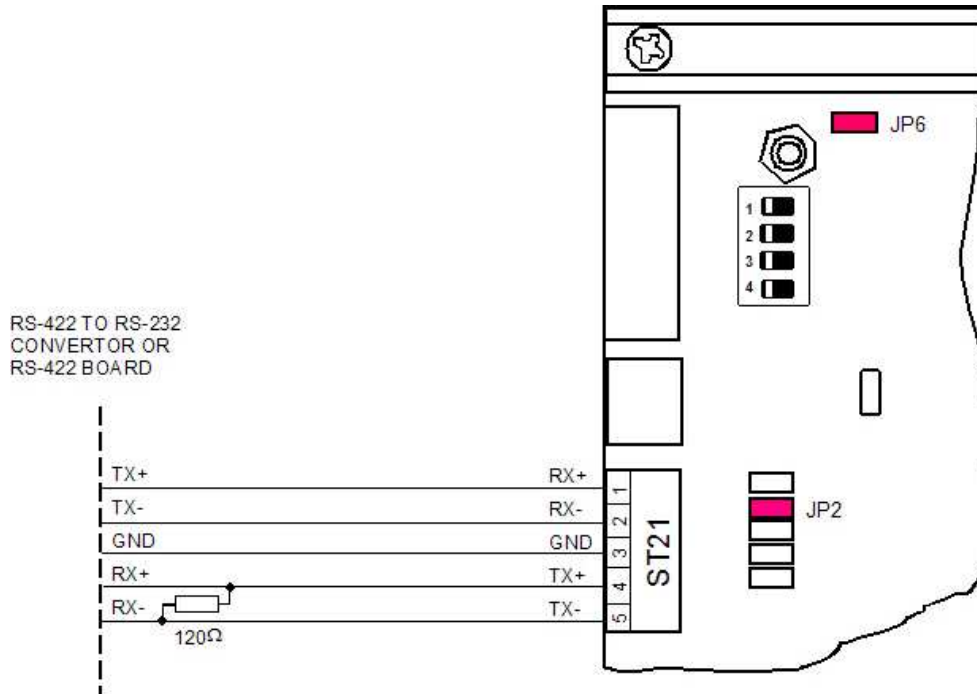

Figure 2-11. RS-422 Interface Connection

2.7.3.2 RS-485 Interface

When using the RS-485 interface, Jumper 4 and 5 (JP4, JP5) must be closed. Recommendations for an RS-485 interface connection to a twisted pair bus are given in [Figure 2-12](#). The last reader on the line must be terminated by connecting Jumper 2 (JP2).

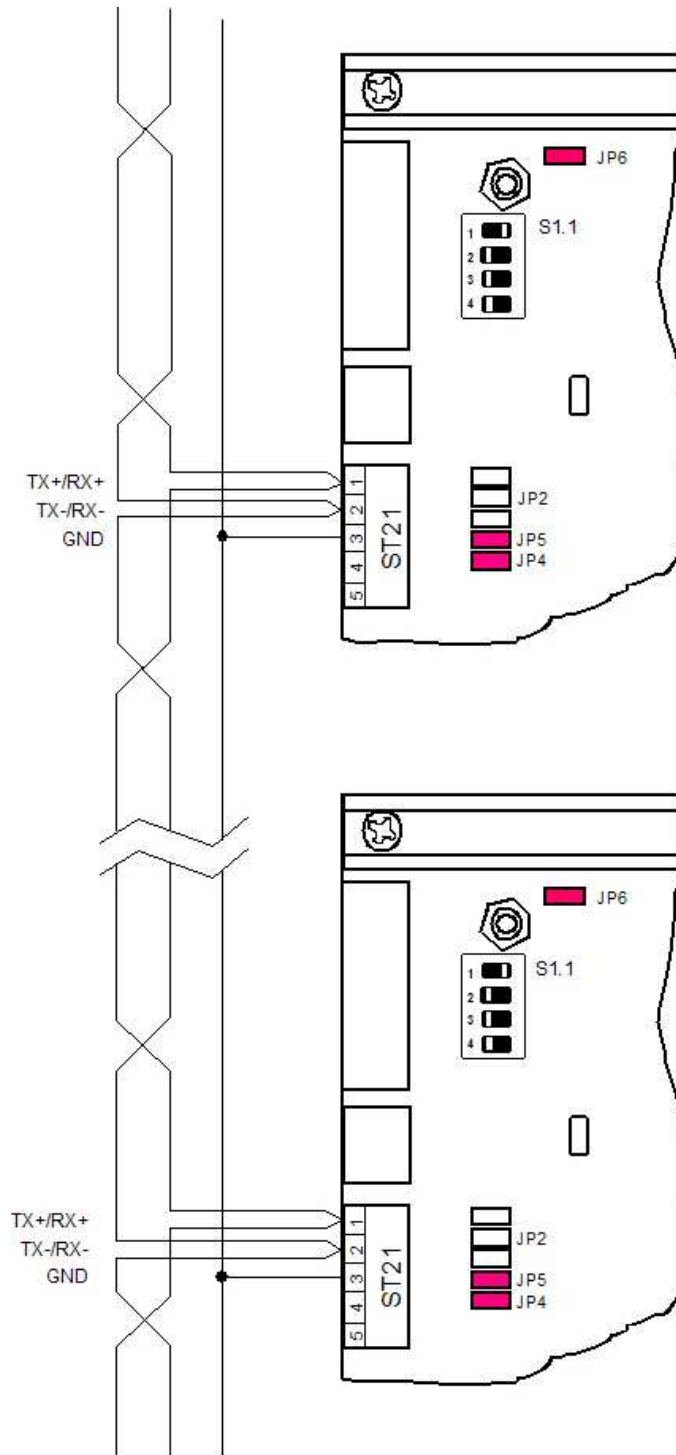

Figure 2-12. RS-485 Interface Connection

2.8 Synchronization Interface

2.8.1 Synchronization Interface

Figure 2-13 shows the circuitry of the synchronization Interface, and Figure 2-14 shows the connector to the interface.

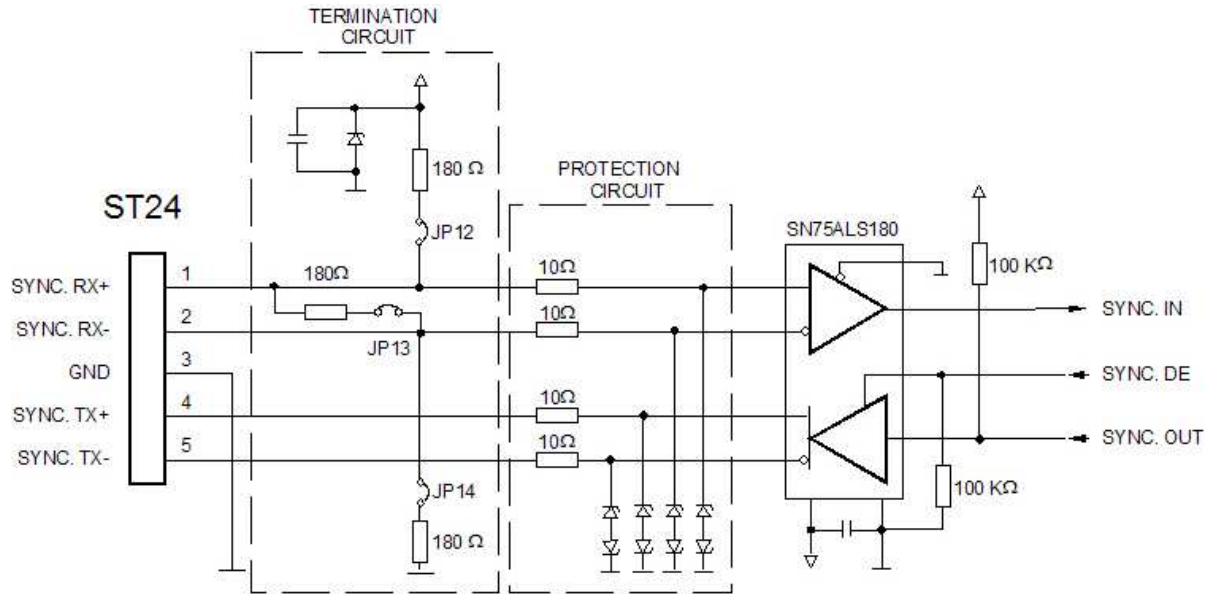

Figure 2-13. Synchronization Interface Circuitry

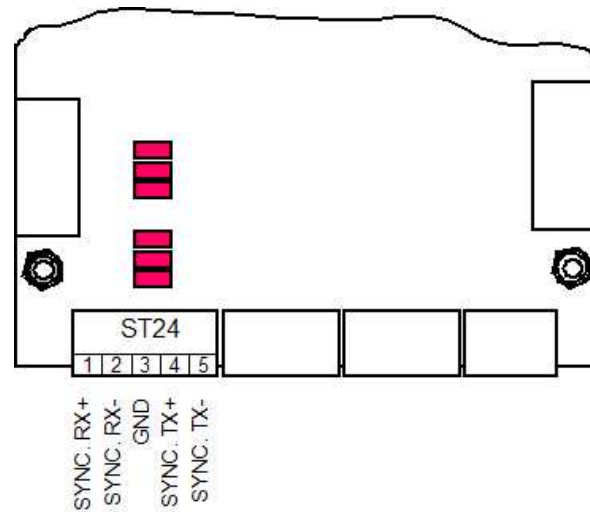

Figure 2-14. Synchronization Interface Connector

To allow the synchronization of up to 32 readers, the Series 2000 firmware provides six types of synchronization (or No Sync if you are not going to use synchronization)

- Wireless synchronization
- Wireless
- Wired
- Combined wireless/wired
- Master/slave (with or without acknowledgement)
- Triggered

This specification covers the way the readers have to be connected for the wired, combined wireless/wired, Master/Slave and triggered synchronization.

When you have completed the hardware synchronization, you must run the configuration utility (S2_Util.exe) as described in Section 2.4, in order to tell the system which synchronization method you have installed, and then set the dipswitch S1.1 to the ON position.

2.8.2 Wired and Combined Wireless/Wired Synchronization

Figure 2-15 shows the way in which the Control Module must be connected for a wired and combined wireless and wired synchronization. The Control Module also has to be software configured to the chosen synchronization method. Table 2-13 explains the setting of jumpers 12, 13 and 14 (JP12, JP13 and JP14).

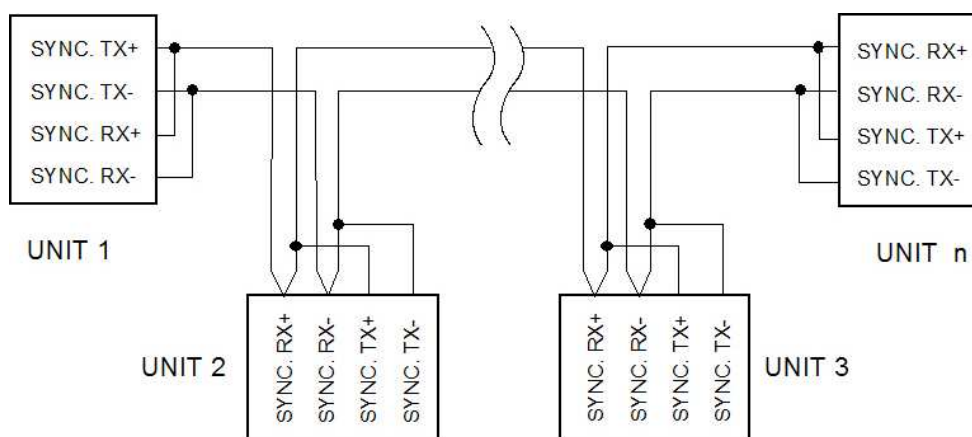

Figure 2-15. Wired and/or Combined Wireless/Wired Synchronization

Table 2-13. Wired and Combined Wireless/Wired Synchronization

	UNIT(1)	UNIT(2) to UNIT(n-1)	UNIT(n)
Jumper 12 (JP12)	Closed	Open	Closed
Jumper 13 (JP13)	Closed ⁽¹⁾	Open	Closed ⁽¹⁾
Jumper 14 (JP14)	Closed	Open	Closed

⁽¹⁾ If the distance between Unit(1) and Unit(n) is less than approximately 400 m, Jumper 13 (JP13) can be left out.

2.8.3 Master/ Slave Synchronization without Acknowledgement; Triggered Synchronization without Acknowledgement

Figure 2-16 shows the way that the Series 2000 readers have to be connected for Master/ Slave synchronization or Triggered synchronization, both without acknowledgement. The individual SW configuration (Master or Slave) is shown in Table 2-14 and Table 2-15. The tables also explain the setting of jumpers 12, 13 and 14 (JP12, JP13 and JP14).

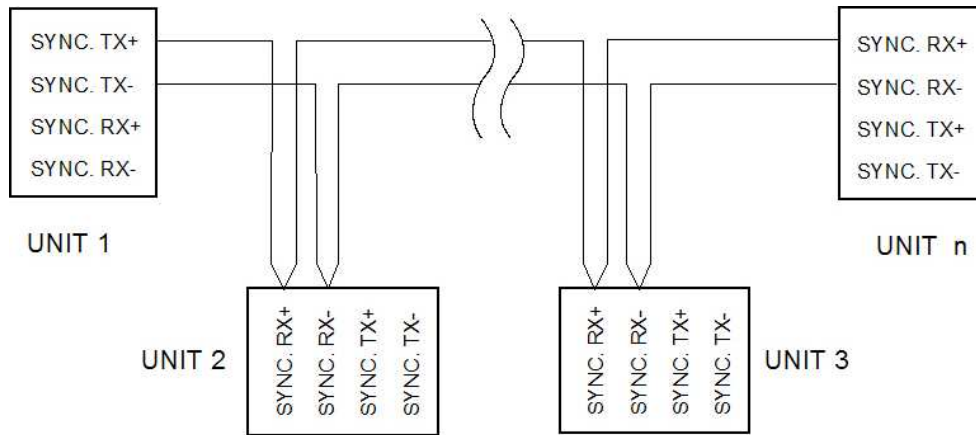

Figure 2-16. Synchronization Interface Connection

Table 2-14. Master/Slave Synchronization without Acknowledgement

	UNIT(1) Control Module MASTER	UNIT(2) to UNIT(n-1) Control Module SLAVES	UNIT(n) Control Module SLAVE
Jumper 12 (JP12)	Closed	Open	Closed
Jumper 13 (JP13)	Open	Open	Closed ⁽¹⁾
Jumper 14 (JP14)	Closed	Open	Closed

⁽¹⁾ If the distance between Unit(1) and Unit(n) is less than approximately 400 m, Jumper 13 (JP13) can be left out.

Table 2-15. Triggered Synchronization without Acknowledgement

	UNIT(1) Trigger Unit	UNIT(2) to UNIT(n-1) Control Module MASTERS	UNIT(n) Control Module MASTER
Jumper 12 (JP12)	Termination not required	Open	Closed
Jumper 13 (JP13)	Termination not required	Open	Closed ⁽¹⁾
Jumper 14 (JP14)	Termination not required	Open	Closed

⁽¹⁾ If the distance between Unit(1) and Unit(n) is less than approximately 400 m, Jumper 13 (JP13) can be left out.

2.8.4 Master/Slave Synchronization With Acknowledgement

Figure 2-17 shows the way that the Control Module must be connected for Master/Slave synchronization with acknowledgement. The individual SW configuration (Master or Slave) is shown in Table 2-16 which also explains the setting of jumpers 12, 13 and 14 (JP12, JP13 and JP14).

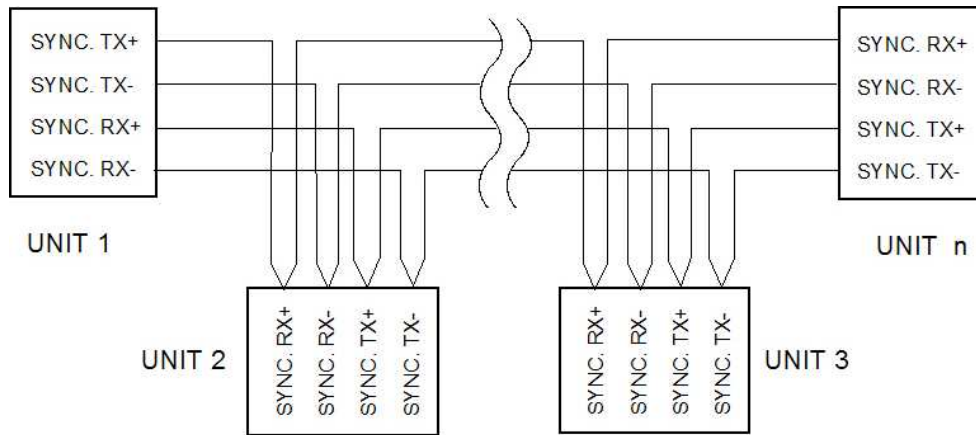

Figure 2-17. Master/Slave Synchronization With Acknowledgment

Table 2-16. Master/Slave Synchronization With Acknowledgement

	UNIT(1) Control Module MASTER	UNIT(2) to UNIT(n-1) Control Module SLAVES	UNIT(n) Control Module SLAVE
Jumper 12 (JP12)	Closed	Open	Closed
Jumper 13 (JP13)	Closed ⁽¹⁾	Open	Closed ⁽¹⁾
Jumper 14 (JP14)	Closed	Open	Closed

⁽¹⁾ If the distance between Unit(1) and Unit(n) is less than approximately 400 m, Jumper 13 (JP13) can be left out.

2.9 Input/Reset

The Control Module provides two general purpose input lines. Each of these input lines is pulled up to VCC2 (+ 5V) by a 100 kΩ resistor.

The Reset-terminal at this connector can be used to reset external circuitry or to reset the Control Module externally. [Figure 2-18](#) shows an example to reset the Control Module with an external push button.

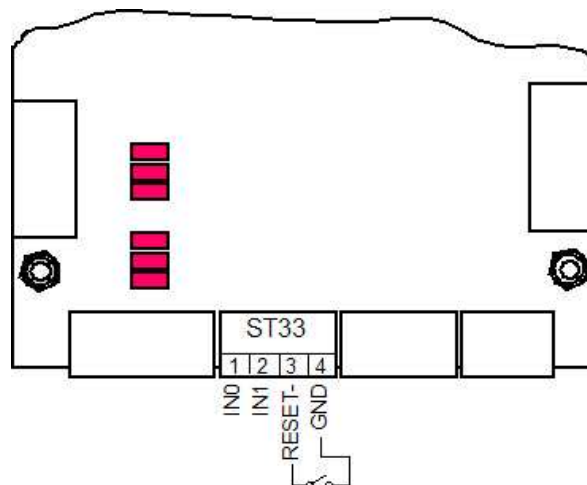

Figure 2-18. Input/Reset Connection

2.10 Indicator Outputs

The signals of the indicator LEDs are available at ST32. They can be used to drive external LEDs which can be mounted on a front Panel. A current limiting resistor is required for each LED. An example is shown in [Figure 2-19](#).

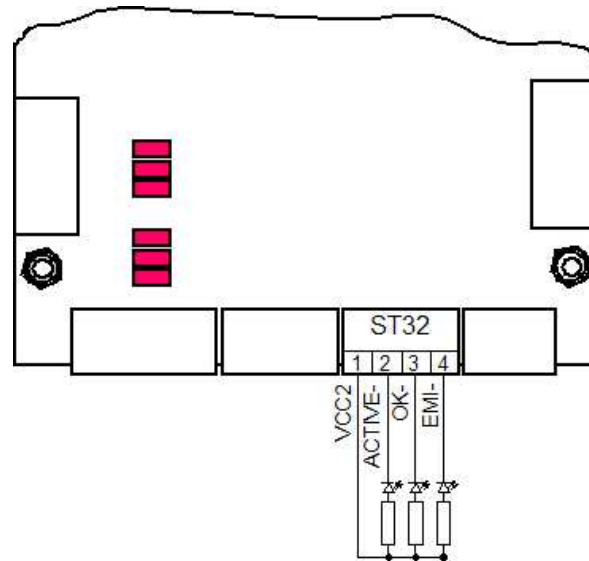

Figure 2-19. Indicator Outputs

2.11 RFM RXSS Tuning Inputs

The signal RXSA is made available at ST31 terminal 1 to allow adjustment of the signal strength threshold level for the S2000 RFM. To adjust the signal strength threshold level please refer to the RFM manual (RSCA and RSCB are not used).

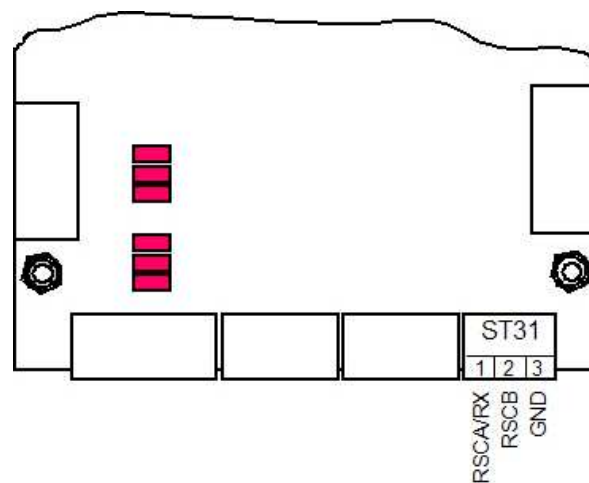

Figure 2-20. RFM Tuning Inputs

2.12 General Purpose I/O

The Control Module provides two I/O ports which can be configured in the following way:

I/O ⁽¹⁾				I/O			
0	1	2	3	4	5	6	7
I	I	I	I	I	I	I	I
I	I	I	I	O	O	O	O
O	O	O	O	I	I	I	I
O	O	O	O	O	O	O	O

(1) I = Input, O = Output

The Control Module firmware configures I/O ports 0 – 3 as Inputs and I/O ports 4 – 7 as Outputs by default.

S2_Util.exe can be used to reconfigure the system as required.

Please do not exceed the values given under Electrical Characteristics in Chapter 3 of this guide. The pin assignments for the I/O are shown in [Figure 2-21](#).

These I/O lines are TTL compatible and are connected via a 220 Ω series resistor to the input terminals of the 82C55A CMOS Programmable Peripheral Interface IC (Port C).

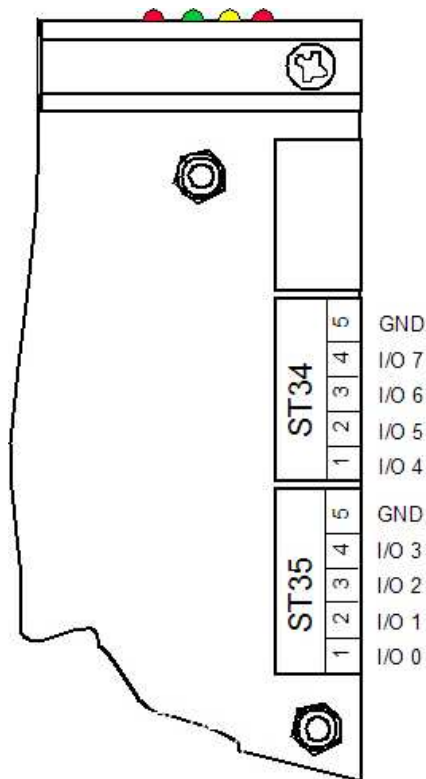

Figure 2-21. General Purpose I/O Port Pin Assignment

2.13 Open Collector Outputs

The Control Module Provides two general purpose open collector output lines. They can be used for a Wiegand interface or to drive relays.

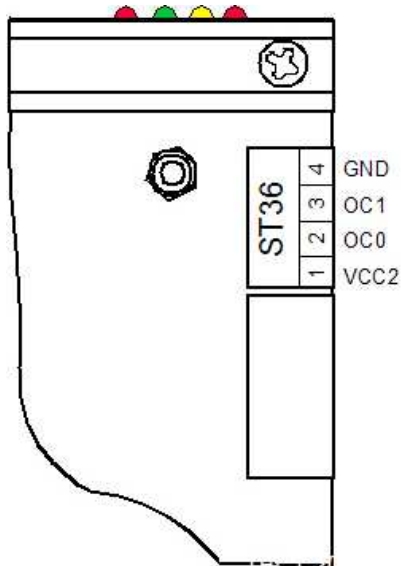

Figure 2-22. Open Collector Outputs

Specifications

The Chapter provides the mechanical and electrical specifications for the Series 2000 Control Module.

Topic	Page
3.1 General Data	34
3.1.1 Mechanical Dimensions	34
3.1.2 Temperature	35
3.2 Electrical Data	35
3.2.1 Recommended Operating Conditions, Electrical Characteristics	35

3.1 General Data

3.1.1 Mechanical Dimensions

Length	:93 mm (3.66 inches)
Width	:82 mm (3.23 inches)
Height	:33 mm (1.14 inches)
Weight	:78 g (2.76 oz)

The dimensions for the holes are given in [Figure 3-1](#). All dimensions are in mm and are given for the Printed Circuit Board (PCB) without the heat sink.

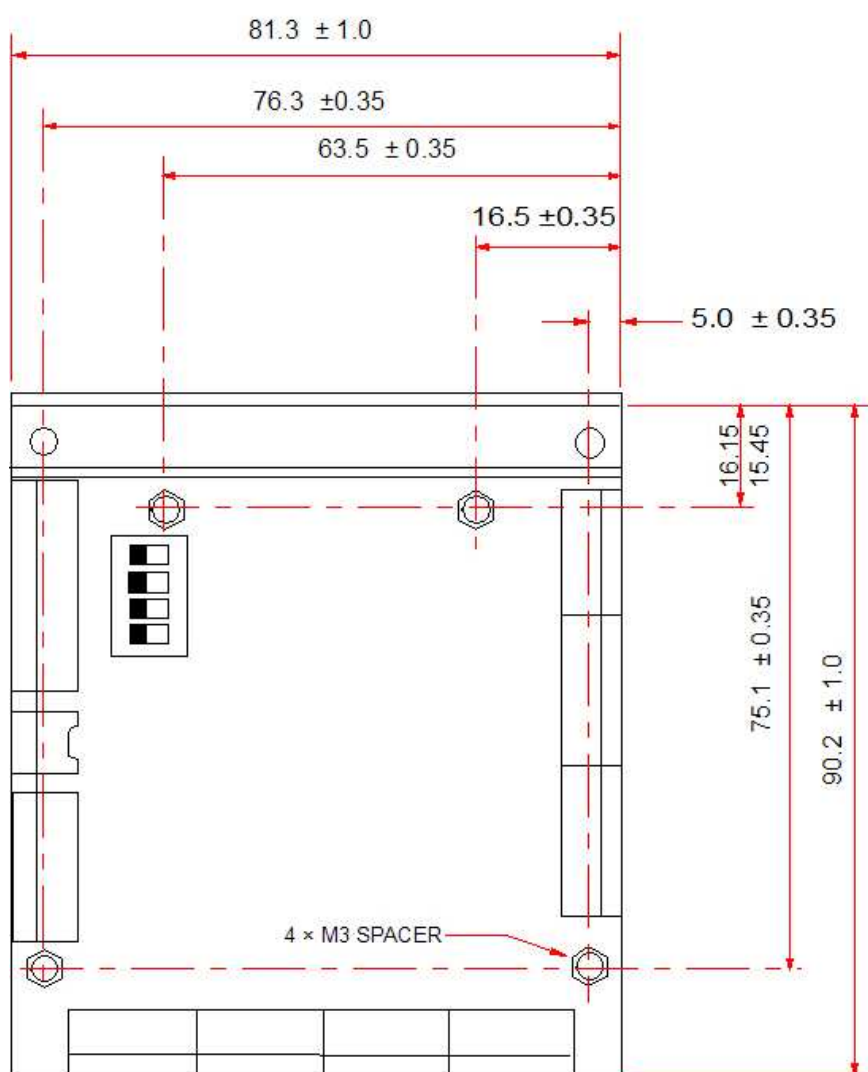

Figure 3-1. Mechanical Dimensions

3.1.2 Temperature

Operating temperature range: 0 to +70°C

Storage temperature range : -40 to + 85°C

3.2 Electrical Data

3.2.1 Recommended Operating Conditions, Electrical Characteristics

3.2.1.1 ST22 – Supply

PARAMETER	DESCRIPTION	CONDITIONS	MIN	TYP	MAX	UNIT
V _{DC}			7		25	V
V _{CC2}	Logic Supply Voltage	Connector ST22 pin 5 is used as logic supply output. V _{DC} = 7 to 25 V. Jumper JP6 must be closed.	4.75	5.0	5.25	V
P _{DIS}	Power dissipated by the voltage regulator	No external loads. Indicator LEDs are on.			4	W
I _{DC} , I _{CC2}	Supply Current	No external loads. Indicator LEDs are on.		120	200	mA
I _{CC2}		Output current if ST22 pin 5 is used as external logic supply output. The maximum power dissipation must not be exceeded!			1	A
V _{CC2}	Data retention input voltage		2.7	3.0	V _{CC2}	V
I _{CC2}	Data retention current	RESET = V _{RESOL} (Reset active) ⁽¹⁾		2	50	μA

- (1) A reset can be initiated in one of three ways:
- Internally by the reset/watchdog circuit
 - Externally by using the reset input (pin 3 of ST33)
 - Externally by the RS-232 DTR signal (RI-CTL-MB2B only)

3.2.1.2 ST21 – RS-232-C Communication Interface

PARAMETER	DESCRIPTION	CONDITIONS	MIN	TYP.	MAX	UNIT
V _{TXD}	Output Voltage Swing	TXD loaded 3 kΩ to Ground	= 5		= 9	V
V _{RXD}	Input voltage range		-30		30	V
V _{DTR}	DTR input voltage		-30		30	V
V _{DSR}	DSR Output voltage	DSR loaded 3 kΩ to Ground	3.5	4.1	V _{CC2}	V
V _{RXD_TRES}	Low	RXD input threshold V _{CC2} = 5 V	0.8			V
	High		2.4			
V _{DTR_TRES}	Low	DTR input threshold V _{CC2} = 5 V	1.6			V
	High		2.25			
ITXD	Short circuit current	TXD connected to ground, infinite duration	±18			mA
RRXD			3	5	7	kΩ
IDTR	DTR current	V _{DTR} = 12 V	3.6	3.8	4.1	mA

3.2.1.3 ST21 – RS-422/RS-485 Communication Interface

PARAMETER	DESCRIPTION	CONDITIONS		MIN	TYP	MAX	UNIT
V_I, V_{IC}	Voltage at any bus terminal (separately or common mode)			-7		+12	V
V_{IC}	Differential input voltage ⁽¹⁾					± 12	V
V_O	Output voltage	$I_O = 0$		0		V_{CC2}	V
I_O	Output current	Output disabled, $V_O = 12$ V				1	mA
I_{OH}	High-level output current	TX+, TX-				-60	mA
		RX+, RX-				-400	
I_{OL}	Low-level output current	TX+, TX-				60	mA
		RX+, RX-				8	
I_{OS}	Short circuit current	Duration should not exceed 1 second	$V_O = 0$ V			-150	mA
			$V_O = V_{CC2}$			-250	
$ V_{OD1} $	Differential output voltage	$I_O = 0$		1.5		V_{CC2}	V
$ V_{OD2} $	Differential output voltage	$R_L = 54 \Omega$		1.5	2.5	V_{CC2}	V
V_{TH}	Differential input high threshold voltage	$V_O = 2.7$ V, $I_O = 0.4$ mA		+0.3			V
V_{TL}	Differential input low threshold voltage	$V_O = 0.5$ V, $I_O = 8$ mA				-0.3	V
R_I	Input resistance			12			k Ω

(1) Differential input/output voltage is measured at the one-inverting terminals RX+/TX+ with respect to the inverting terminals RX-/TX-.

3.2.1.4 ST24 – Synchronization Interface

PARAMETER	DESCRIPTION	CONDITIONS		MIN	TYP	MAX	UNIT
V_{SYNC_I}, V_{SYNC_IC}	Voltage at any bus terminal (separately or common mode)			-7		+12	V
V_{SYNC_ID}	Differential input voltage					⁽¹⁾ ± 12	V
V_{SYNC_O}	Output voltage	$I_O = 0$				V_{CC2}	V
I_{SYNC_O}	Output current	Output disabled, $V_O = 12$ V				1	mA
I_{SYNC_OH}	High-level output current	TX+, TX-				-60	mA
		RX+, RX-				-400	
I_{SYNC_OL}	Low-level output current	TX+, TX-				60	mA
		RX+, RX-				8	
I_{SYNC_OS}	Short circuit current	Duration should not exceed 1 second	$V_O = 0$ V			-150	mA
			$V_O = V_{CC2}$			-250	
$ V_{SYNC_OD1} $	Differential output voltage	$I_O = 0$		1.5		V_{CC2}	V
$ V_{SYNC_OD2} $	Differential output voltage	$R_L = 54 \Omega$		1.5	2.5	V_{CC2}	V
V_{SYNC_TH}	Differential input high threshold voltage	$V_O = 2.7$ V, $I_O = 0.4$ mA		+0.3			V
V_{SYNC_TL}	Differential input low threshold voltage	$V_O = 0.5$ V, $I_O = 8$ mA				-0.3	V
R_{SYNC_I}	Input resistance			12			k Ω

(1) Differential input/output voltage is measured at the non-inverting terminals RX+/TX+ with respect to the inverting terminals RX-/TX-.

3.2.1.5 ST33 – Input/Reset

PARAMETER	DESCRIPTION	CONDITIONS	MIN	TYP	MAX	UNIT
V _{RESOH}	Reset high level output voltage, ST33 pin 3	I _{OH} = 20 μA	3.8	4.1	V _{CC2}	V
		Reset/watchdog circuit inactive. See and DTR=VDTRL (RS-232 version) ⁽¹⁾				
V _{RESOL}	Reset low level output voltage, ST33 pin 3	I _{OL} = 10 μA			0.8	V
		Reset/watchdog circuit inactive. See DTR=VDTRL (RS-232 version) ⁽²⁾				
V _{RESIL}	Reset low level input voltage, ST33 pin 3	Output disabled; V _O = 12 V			0.8	V
V _{IN0L} , V _{IN1L}	Low level input voltage for input 0 and input 1				0.8	V
V _{IN0H} , V _{IN1H}	High level input voltage for input 0 and input 1		2.2	V _{CC2} – 0.3		V
I _{ILL}	Input leak current	0 ≤ V _{IN} < +V _{CC2}	–1		1	μA
t _{RESOL}	Reset output low-level pulse duration		10	16		ms
t _{RESIL}	Reset input low-level pulse duration		10	16		ms

(1) Differential input/output voltage is measured at the non-inverting terminals RX+/TX+ with respect to the inverting terminals RX-/TX-.

(2) A reset of the Rest/watchdog circuit is initiated if:

- The logic supply voltage (V_{CC2}) is below 4.65 Volt
- The watchdog is not periodically retriggered within 50 ms

3.2.1.6 Indicator Outputs

PARAMETER	DESCRIPTION	CONDITIONS	MIN	TYP	MAX	UNIT
V _{OH}	High level output voltage				10	V
V _{OL}	Low level output voltage	I _{OL} = 100 mA			1	V
V _{IL}	Low level output current				290	mA
t _{OK_TRG}	Low level trigger signal pulse width		⁽¹⁾ 40	50		μs
t _{OK_DELAY}	Delay to the low-to-high transition of the trigger signal		⁽²⁾ 50	70	90	ms

(1) The OK_LED (ON) and the OK_LED(OFF) functions of the S2000 software library can be used to generate a trigger signal.

(2) The pulse extension circuit is only added for the OK-signal.

3.2.1.7 ST31 – RFM RXSS Tuning Inputs

For the electrical characteristics of the RXSA input, please refer to the relevant RFM manual.

Electrical Data
3.2.1.8 ST35/34 – General Purpose I/O

PARAMETER	DESCRIPTION	CONDITIONS	MIN	TYP.	MAX	UNIT
V _{OH}	High level output voltage	I _{OH} = -40 mA	4.2			V
		I _{OH} = -1.6 mA	3.4			
V _{OL}	Low level output voltage	I _{OL} = 1.6 mA			0.8	V
V _{IL}	Low level input voltage				0.8	V
V _{IH}	High level input voltage		2.2	V _{CC2} + 0.3		V
I _{LI}	Input leak current	0 ≤ V _{IN} ≤ V _{CC2}	-1		1	μA

Note: For more details please refer to the data sheet for the SN74LVC2T45 programmable Peripheral Interface IC. All the I/O lines have a 220 Ω series resistor.

3.2.1.9 ST36 – Open Collector Outputs

PARAMETER	DESCRIPTION	CONDITIONS	MIN	TYP	MAX	UNIT
V _{CC2}	+5 V Output	The total consumption of the two VCC outputs (GEN I/O pin 13 and OC pin 1) must not exceed 500 mA	4.75	5	5.25	V
V _{OH}	High level output voltage				80	V
V _{OL}	Low level output voltage	I _{OL} = 500 mA			1.3	V
I _{OL}	Low level output current				500	mA

Terms and Abbreviations

A document explaining the various terms and abbreviations used in Texas Instruments' RFID Publications can be found on Texas Instruments website www.ti.rfid.com

"Terms and Abbreviations" (11-03-21-002).

IMPORTANT NOTICE

Texas Instruments Incorporated and its subsidiaries (TI) reserve the right to make corrections, modifications, enhancements, improvements, and other changes to its products and services at any time and to discontinue any product or service without notice. Customers should obtain the latest relevant information before placing orders and should verify that such information is current and complete. All products are sold subject to TI's terms and conditions of sale supplied at the time of order acknowledgment.

TI warrants performance of its hardware products to the specifications applicable at the time of sale in accordance with TI's standard warranty. Testing and other quality control techniques are used to the extent TI deems necessary to support this warranty. Except where mandated by government requirements, testing of all parameters of each product is not necessarily performed.

TI assumes no liability for applications assistance or customer product design. Customers are responsible for their products and applications using TI components. To minimize the risks associated with customer products and applications, customers should provide adequate design and operating safeguards.

TI does not warrant or represent that any license, either express or implied, is granted under any TI patent right, copyright, mask work right, or other TI intellectual property right relating to any combination, machine, or process in which TI products or services are used. Information published by TI regarding third-party products or services does not constitute a license from TI to use such products or services or a warranty or endorsement thereof. Use of such information may require a license from a third party under the patents or other intellectual property of the third party, or a license from TI under the patents or other intellectual property of TI.

Reproduction of TI information in TI data books or data sheets is permissible only if reproduction is without alteration and is accompanied by all associated warranties, conditions, limitations, and notices. Reproduction of this information with alteration is an unfair and deceptive business practice. TI is not responsible or liable for such altered documentation. Information of third parties may be subject to additional restrictions.

Resale of TI products or services with statements different from or beyond the parameters stated by TI for that product or service voids all express and any implied warranties for the associated TI product or service and is an unfair and deceptive business practice. TI is not responsible or liable for any such statements.

TI products are not authorized for use in safety-critical applications (such as life support) where a failure of the TI product would reasonably be expected to cause severe personal injury or death, unless officers of the parties have executed an agreement specifically governing such use. Buyers represent that they have all necessary expertise in the safety and regulatory ramifications of their applications, and acknowledge and agree that they are solely responsible for all legal, regulatory and safety-related requirements concerning their products and any use of TI products in such safety-critical applications, notwithstanding any applications-related information or support that may be provided by TI. Further, Buyers must fully indemnify TI and its representatives against any damages arising out of the use of TI products in such safety-critical applications.

TI products are neither designed nor intended for use in military/aerospace applications or environments unless the TI products are specifically designated by TI as military-grade or "enhanced plastic." Only products designated by TI as military-grade meet military specifications. Buyers acknowledge and agree that any such use of TI products which TI has not designated as military-grade is solely at the Buyer's risk, and that they are solely responsible for compliance with all legal and regulatory requirements in connection with such use.

TI products are neither designed nor intended for use in automotive applications or environments unless the specific TI products are designated by TI as compliant with ISO/TS 16949 requirements. Buyers acknowledge and agree that, if they use any non-designated products in automotive applications, TI will not be responsible for any failure to meet such requirements.

Following are URLs where you can obtain information on other Texas Instruments products and application solutions:

Products

Amplifiers	amplifier.ti.com
Data Converters	dataconverter.ti.com
DSP	dsp.ti.com
Clocks and Timers	www.ti.com/clocks
Interface	interface.ti.com
Logic	logic.ti.com
Power Mgmt	power.ti.com
Microcontrollers	microcontroller.ti.com
RFID	www.ti-rfid.com
RF/IF and ZigBee® Solutions	www.ti.com/lprf

Applications

Audio	www.ti.com/audio
Automotive	www.ti.com/automotive
Broadband	www.ti.com/broadband
Digital Control	www.ti.com/digitalcontrol
Medical	www.ti.com/medical
Military	www.ti.com/military
Optical Networking	www.ti.com/opticalnetwork
Security	www.ti.com/security
Telephony	www.ti.com/telephony
Video & Imaging	www.ti.com/video
Wireless	www.ti.com/wireless

Mailing Address: Texas Instruments, Post Office Box 655303, Dallas, Texas 75265
Copyright 2008, Texas Instruments Incorporated