

Quad dual-input and gate

Datasheet - production data

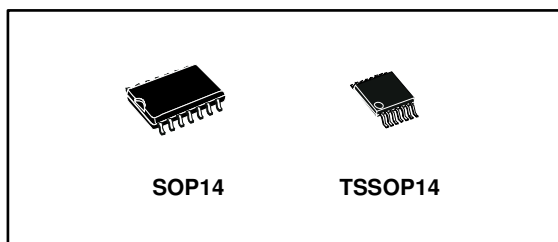

Features

- High speed: $t_{PD} = 7 \text{ ns}$ (typ.) at $V_{CC} = 6 \text{ V}$
- Low power dissipation: $I_{CC} = 1 \mu\text{A}$ (max.) at $T_A = 25 \text{ }^\circ\text{C}$
- High noise immunity: $V_{NIH} = V_{NIL} = 28 \% V_{CC}$ (min.)
- Symmetrical output impedance: $|I_{OH}| = I_{OL} = 4 \text{ mA}$ (min)
- Balanced propagation delays: $t_{PLH} \approx t_{PHL}$
- Wide operating voltage range: V_{CC} (OPR) = 2 V to 6 V
- Pin and function compatible with 74 series 08
- ESD performance
 - CDM: 1 kV
 - HBM: 2 kV
 - MM: 200 V

Description

The M74HC08 is a high-speed CMOS quad dual-input and gate fabricated with silicon gate C²MOS technology.

The internal circuit is composed of two stages including a buffer output which enables high noise immunity and stable output.

All inputs are equipped with protection circuits to guard against static discharge and transient excess voltage.

Table 1: Device summary

Order code	Temperature range	Package	Packaging	Marking
M74HC08YRM13TR ⁽¹⁾	-40 °C to +125 °C	SO14 (automotive grade) ¹	Tape and reel	74HC08Y
M74HC08RM13TR	-55 °C to +125 °C	SO14	Tape and reel	74HC08
M74HC08TTR	-55 °C to +125 °C	TSSOP14	Tape and reel	HC08
M74HC08YTTR ¹	-40 °C to +125 °C	TSSOP14 (automotive grade) ¹	Tape and reel	HC08Y

Notes:

⁽¹⁾Qualification and characterization according to AEC Q100 and Q003 or equivalent, advanced screening according to AEC Q001 and Q002 or equivalent.

Contents

1	Pin information	5
2	Functional description	6
3	Electrical characteristics	7
4	Package information	11
	4.1 SO14 package information.....	12
	4.2 TSSOP14 package information.....	13
5	Revision history	14

List of tables

Table 1: Device summary	1
Table 2: Pin description	5
Table 3: Truth table	6
Table 4: Absolute maximum ratings	7
Table 5: Recommended operating conditions	7
Table 6: DC specifications	8
Table 7: AC electrical characteristics ($C_L = 50$ pF, input $t_r = t_f = 6$ ns)	9
Table 8: Capacitive characteristics	9
Table 9: Plastic SO14 package mechanical data	12
Table 10: TSSOP14 package mechanical data	13

List of figures

Figure 1: Pin connections and IEC logic symbols	5
Figure 2: Input and output equivalent circuit.....	6
Figure 3: Test circuit	10
Figure 4: Waveforms: propagation delay times (f = 1 MHz; 50% duty cycle).....	10
Figure 5: Plastic SO14 package mechanical outline	12
Figure 6: TSSOP14 package mechanical outline.....	13

1 Pin information

Figure 1: Pin connections and IEC logic symbols

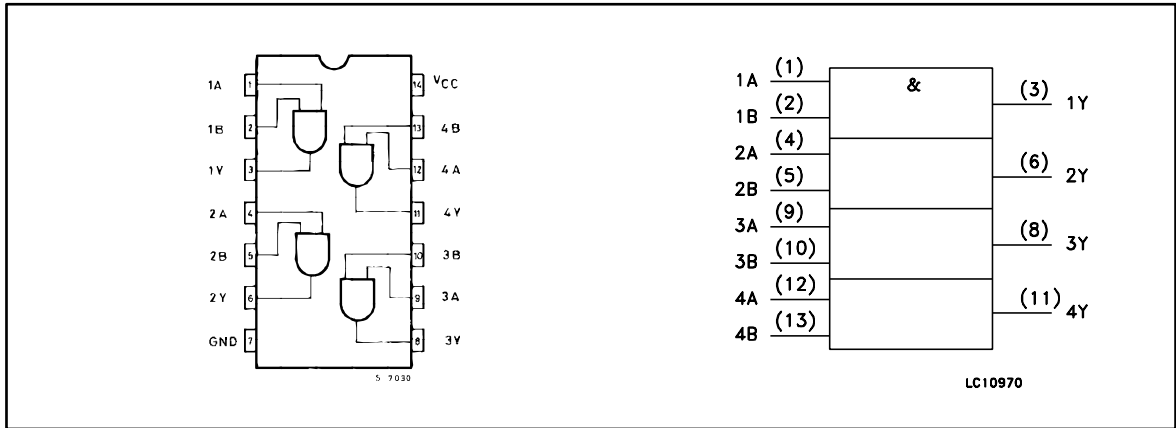

Table 2: Pin description

Pin number	Symbol	Name and function
1, 4, 9, 12	1A to 4A	Data inputs
2, 5, 10, 13	1B to 4B	Data inputs
3, 6, 8, 11	1Y to 4Y	Data outputs
7	GND	Ground (0 V)
14	V _{CC}	Positive supply voltage

2 Functional description

Table 3: Truth table

A	B	Y
L	L	L
L	H	L
H	L	L
H	H	H

Figure 2: Input and output equivalent circuit

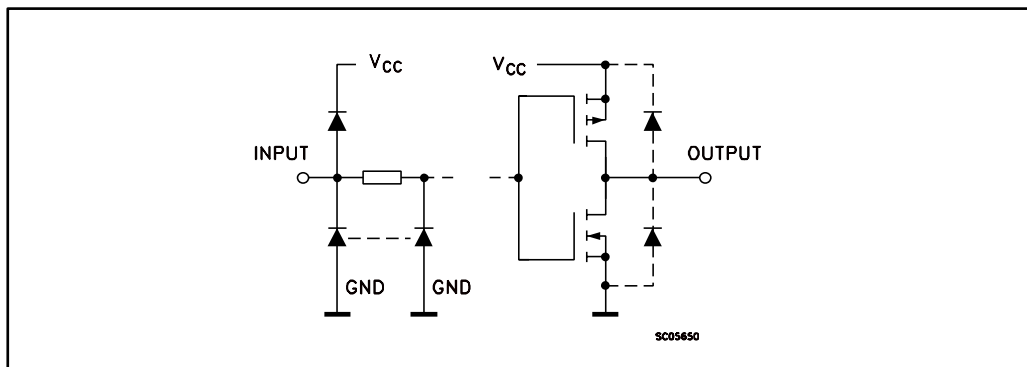

3 Electrical characteristics

Stressing the device above the ratings listed in the "Absolute maximum ratings" table may cause permanent damage to the device. These are stress ratings only, and operation of the device at these or any other conditions above those indicated in the operating sections of this specification are not implied. Exposure to absolute maximum rating conditions for extended periods may affect device reliability.

Table 4: Absolute maximum ratings

Symbol	Parameter	Value	Unit
V_{CC}	Supply voltage	-0.5 to +7	V
V_I	DC input voltage	-0.5 to V_{CC} to +0.5	V
V_O	DC output voltage	-0.5 to V_{CC} to +0.5	V
I_{IK}	DC input diode current	± 20	mA
I_{OK}	DC output diode current	± 20	mA
I_O	DC output current	± 25	mA
I_{CC} or I_{GND}	DC V_{CC} or ground current	± 50	mA
P_D	Power dissipation	500 ⁽¹⁾	mW
T_{stg}	Storage temperature	-65 to +150	°C
T_L	Lead temperature (10 sec.)	300	°C

Notes:

⁽¹⁾500 mW at 65 °C; derate to 300 mW by 10 mW/°C from 65 °C to 85 °C

Table 5: Recommended operating conditions

Symbol	Parameter	Value	Unit	
V_{CC}	Supply voltage	2 to 6	V	
V_I	Input voltage	0 to V_{CC}	V	
V_O	Output voltage	0 to V_{CC}	V	
T_{op}	Operating temperature	-55 to 125	°C	
t_r, t_f	Input rise and fall time	$V_{CC} = 2.0$ V	0 to 1000	ns
		$V_{CC} = 4.5$ V	0 to 500	ns
		$V_{CC} = 6.0$ V	0 to 400	ns

Table 6: DC specifications

Symbol	Parameter	Test condition		Value						Unit	
		V _{CC} (V)		T _A = 25°C			-40 to 85°C		-55 to 125°C		
				Min.	Typ.	Max.	Min.	Max.	Min.		Max.
V _{IH}	High-level input voltage	2.0		1.5			1.5		1.5		V
		4.5		3.15			3.15		3.15		
		6.0		4.2			4.2		4.2		
V _{IL}	Low-level input voltage	2.0				0.5		0.5		0.5	V
		4.5				1.35		1.35		1.35	
		6.0				1.8		1.8		1.8	
V _{OH}	High-level output voltage	2.0	I _O = -20 μA	1.9	2.0		1.9		1.9		V
		4.5	I _O = -20 μA	4.4	4.5		4.4		4.4		
		6.0	I _O = -20 μA	5.9	6.0		5.9		5.9		
		4.5	I _O = -4.0 mA	4.18	4.31		4.13		4.10		
		6.0	I _O = -5.2 mA	5.68	5.8		5.63		5.60		
V _{OL}	Low-level output voltage	2.0	I _O = 20 μA		0.0	0.1		0.1		0.1	V
		4.5	I _O = 20 μA		0.0	0.1		0.1		0.1	
		6.0	I _O = 20 μA		0.0	0.1		0.1		0.1	
		4.5	I _O = 4.0 mA		0.17	0.26		0.33		0.40	
		6.0	I _O = 5.2 mA		0.18	0.26		0.33		0.40	
I _I	Input leakage current	6.0	V _I = V _{CC} or GND			±0.1		±1		±1	μA
I _{CC}	Quiescent supply current	6.0	V _I = V _{CC} or GND			1		10		20	μA

Table 7: AC electrical characteristics ($C_L = 50$ pF, input $t_r = t_f = 6$ ns)

Symbol	Parameter	Test condition	Value							Unit
			$T_A = 25^\circ\text{C}$			-40 to 85°C		-55 to 125°C		
			V_{CC} (V)	Min.	Typ.	Max.	Min.	Max.	Min.	
t_{TLH} t_{THL}	Output transition time	2.0		30	75		95		110	ns
		4.5		8	15		19		22	
		6.0		7	13		16		19	
t_{PLH} t_{PHL}	Propagation delay time	2.0		24	75		95		110	ns
		4.5		8	15		19		22	
		6.0		7	13		16		19	

Table 8: Capacitive characteristics

Symbol	Parameter	Test condition	Value							Unit
			$T_A = 25^\circ\text{C}$			-40 to 85°C		-55 to 125°C		
			V_{CC} (V)	Min.	Typ.	Max.	Min.	Max.	Min.	
C_{IN}	Input capacitance	5.0		5	10		10		10	pF
C_{PD}	Power dissipation capacitance ⁽¹⁾	5.0		19						pF

Notes:

⁽¹⁾ C_{PD} is defined as the value of the IC's internal equivalent capacitance which is calculated from the operating current consumption without load (refer to the test circuit). The average operating current can be obtained by the following equation: $I_{CC(opr)} = C_{PD} \times V_{CC} \times f_{IN} + I_{CC}/4$ (per gate).

Figure 3: Test circuit

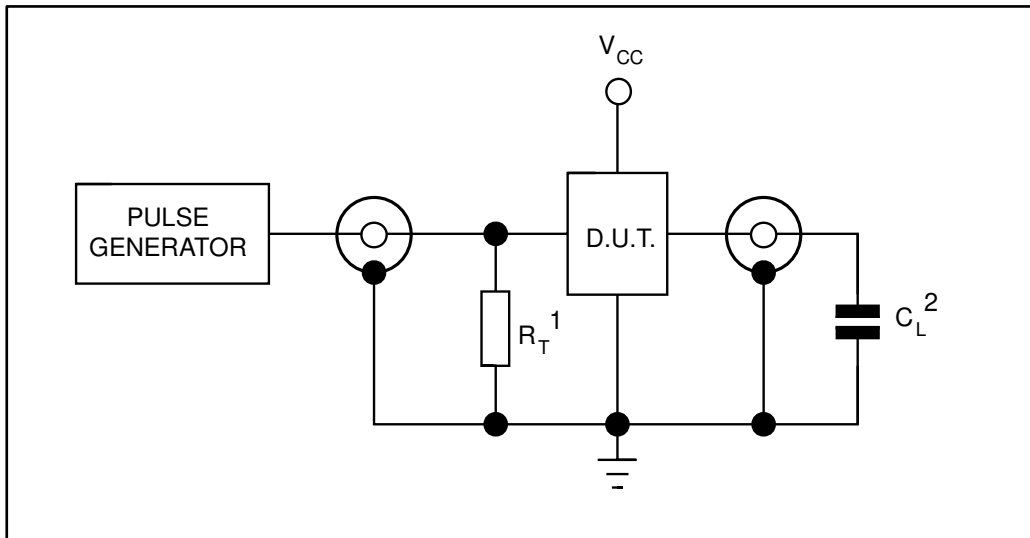

1. $R_T = Z_{OUT}$ of pulse generator (typically 50 ohm)
2. $C_L = 50$ pF or equivalent (includes jig and probe capacitance).

Figure 4: Waveforms: propagation delay times ($f = 1$ MHz; 50% duty cycle)

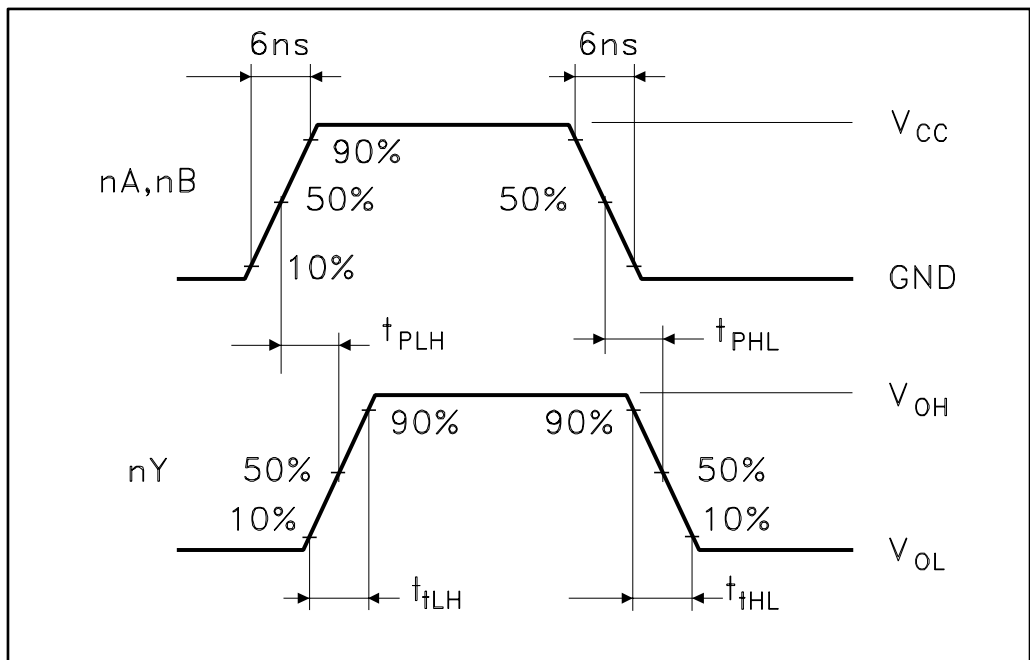

4 Package information

In order to meet environmental requirements, ST offers these devices in different grades of ECOPACK[®] packages, depending on their level of environmental compliance. ECOPACK[®] specifications, grade definitions and product status are available at: www.st.com. ECOPACK[®] is an ST trademark.

4.1 SO14 package information

Figure 5: Plastic SO14 package mechanical outline

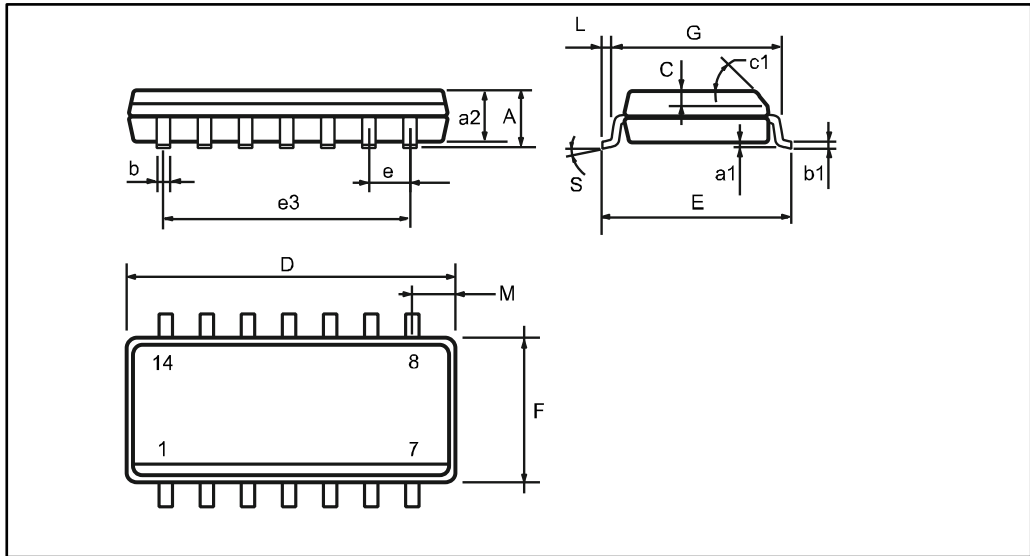

Table 9: Plastic SO14 package mechanical data

Dimensions	mm.			inches		
	Min.	Typ.	Max.	Min.	Typ.	Max.
A			1.75			0.068
a1	0.1		0.2	0.003		0.007
a2			1.65			0.064
b	0.35		0.46	0.013		0.018
b1	0.19		0.25	0.007		0.010
C		0.5			0.019	
c1	45 ° (typ.)					
D	8.55		8.75	0.336		0.344
E	5.8		6.2	0.228		0.244
e		1.27			0.050	
e3		7.62			0.300	
F	3.8		4.0	0.149		0.157
G	4.6		5.3	0.181		0.208
L	0.5		1.27	0.019		0.050
M			0.68			0.026
S	8 ° (max.)					

4.2 TSSOP14 package information

Figure 6: TSSOP14 package mechanical outline

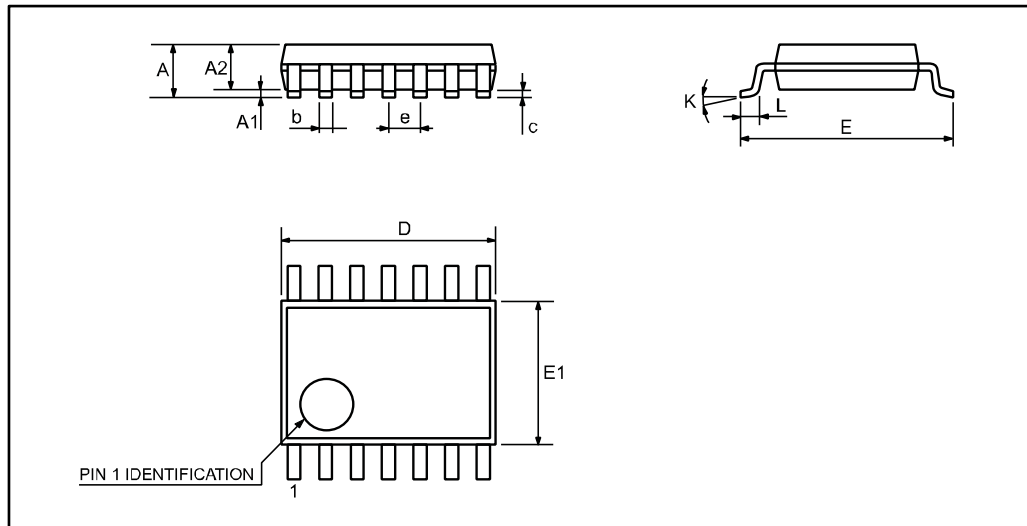

Table 10: TSSOP14 package mechanical data

Dimensions	mm.			inches		
	Min.	Typ.	Max.	Min.	Typ.	Max.
A			1.2			0.047
A1	0.05		0.15	0.002	0.004	0.006
A2	0.8	1	1.05	0.031	0.039	0.041
b	0.19		0.30	0.007		0.012
c	0.09		0.20	0.004		0.0089
D	4.9	5	5.1	0.193	0.197	0.201
E	6.2	6.4	6.6	0.244	0.252	0.260
E1	4.3	4.4	4.48	0.169	0.173	0.176
e		0.65 BSC			0.0256 BSC	
K	0°		8°	0°		8°
L	0.45	0.60	0.75	0.018	0.024	0.030

5 Revision history

Date	Version	Change
Jul-2001	1	Initial release
08-Oct-2013	2	Added ESD performance to Features Added automotive grade order codes, temperature ranges and marking information to Table 1 Removed DIP14 package option from datasheet Revised document presentation Minor textual updates

Please Read Carefully

Information in this document is provided solely in connection with ST products. STMicroelectronics NV and its subsidiaries ("ST") reserve the right to make changes, corrections, modifications or improvements, to this document, and the products and services described herein at any time, without notice.

All ST products are sold pursuant to ST's terms and conditions of sale.

Purchasers are solely responsible for the choice, selection and use of the ST products and services described herein, and ST assumes no liability whatsoever relating to the choice, selection or use of the ST products and services described herein.

No license, express or implied, by estoppel or otherwise, to any intellectual property rights is granted under this document. If any part of this document refers to any third party products or services it shall not be deemed a license grant by ST for the use of such third party products or services, or any intellectual property contained therein or considered as a warranty covering the use in any manner whatsoever of such third party products or services or any intellectual property contained therein.

UNLESS OTHERWISE SET FORTH IN ST'S TERMS AND CONDITIONS OF SALE ST DISCLAIMS ANY EXPRESS OR IMPLIED WARRANTY WITH RESPECT TO THE USE AND/OR SALE OF ST PRODUCTS INCLUDING WITHOUT LIMITATION IMPLIED WARRANTIES OF MERCHANTABILITY, FITNESS FOR A PARTICULAR PURPOSE (AND THEIR EQUIVALENTS UNDER THE LAWS OF ANY JURISDICTION), OR INFRINGEMENT OF ANY PATENT, COPYRIGHT OR OTHER INTELLECTUAL PROPERTY RIGHT.

ST PRODUCTS ARE NOT DESIGNED OR AUTHORIZED FOR USE IN: (A) SAFETY CRITICAL APPLICATIONS SUCH AS LIFE SUPPORTING, ACTIVE IMPLANTED DEVICES OR SYSTEMS WITH PRODUCT FUNCTIONAL SAFETY REQUIREMENTS; (B) AERONAUTIC APPLICATIONS; (C) AUTOMOTIVE APPLICATIONS OR ENVIRONMENTS, AND/OR (D) AEROSPACE APPLICATIONS OR ENVIRONMENTS. WHERE ST PRODUCTS ARE NOT DESIGNED FOR SUCH USE, THE PURCHASER SHALL USE PRODUCTS AT PURCHASER'S SOLE RISK, EVEN IF ST HAS BEEN INFORMED IN WRITING OF SUCH USAGE, UNLESS A PRODUCT IS EXPRESSLY DESIGNATED BY ST AS BEING INTENDED FOR "AUTOMOTIVE, AUTOMOTIVE SAFETY OR MEDICAL" INDUSTRY DOMAINS ACCORDING TO ST PRODUCT DESIGN SPECIFICATIONS. PRODUCTS FORMALLY ESCC, QML OR JAN QUALIFIED ARE DEEMED SUITABLE FOR USE IN AEROSPACE BY THE CORRESPONDING GOVERNMENTAL AGENCY.

Resale of ST products with provisions different from the statements and/or technical features set forth in this document shall immediately void any warranty granted by ST for the ST product or service described herein and shall not create or extend in any manner whatsoever, any liability of ST.

ST and the ST logo are trademarks or registered trademarks of ST in various countries.

Information in this document supersedes and replaces all information previously supplied.

The ST logo is a registered trademark of STMicroelectronics. All other names are the property of their respective owners.

© 2013 STMicroelectronics - All rights reserved

STMicroelectronics group of companies

Australia - Belgium - Brazil - Canada - China - Czech Republic - Finland - France - Germany - Hong Kong - India - Israel - Italy
- Japan - Malaysia - Malta - Morocco - Philippines - Singapore - Spain - Sweden - Switzerland - United Kingdom - United
States of America

www.st.com