

REVISION RECORD		
REV	DESCRIPTION	DRFT
11	OLD DRAWING CHECK IN	AMY 10/16/07
12	CONTACT RESISTANCE: FROM 30 TO 50 MILLIOHMS MAX	SIX 9/21/2010

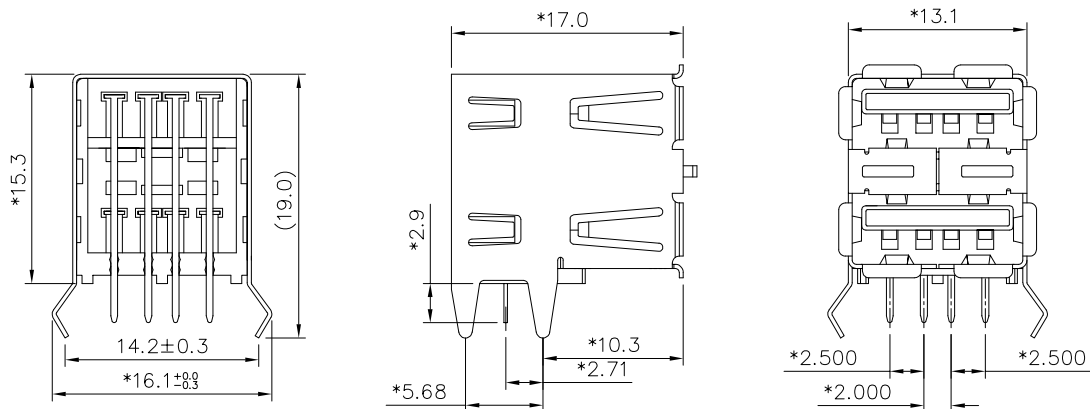

NOTES:

- MATERIAL:
TERMINAL—C5191 PHOSPHOR BRONZE HARD. (t=0.25mm)
SHIELD—(t=0.30mm)COPPER ALLOY OR PHOSPHOR BRONZE.
HOUSING—PBT+ 30% G.F. UL94V-0/COLOR:WHITE & BLACK.
- PLATING:
CONTACT—AREA—SELECTIVE PLATING. ON THE MATING END.
TAILS—150u" TIN—LEAD MIN OVER 50u" NICKEL.
SHIELD—120u" TIN—LEAD MIN OVER 50u" NICKEL.
OR 100u"~120u" NI OVER 40u" Cu.
- TOLERANCE: ±0.3mm.±3°.
- GAP. 0.25mm (Max.)
- ELECTRICAL:
VOLTAGE RATING: 30 VAC RMS.
CURRENT RATING: 1.0 AMP
- CONTACT RESISTANCE: 50 MILLIOHMS MAX
INSULATION RESISTANCE: 1000 MEGOHMS MIN @500 VDC
DIELECTRIC STRENGTH: 750 VAC RMS 60 HZ, 1 MIN
OPERATING LIFE: 1500 CYCLES MIN
MATING FORCE: 3.5 KGS MAX
UNMATING FORE: 1 KGS MIN
STORAGE: -40°C TO +85°C
OPERATION: -40°C TO+85°C
CAPACITANCE: 2 PF MAX 1KHZ
WAVE SOLDERING TEMPERATURE 230-250(3~5 SECONDS)
6.FRE OLD DRAWING NUMBER GE813013

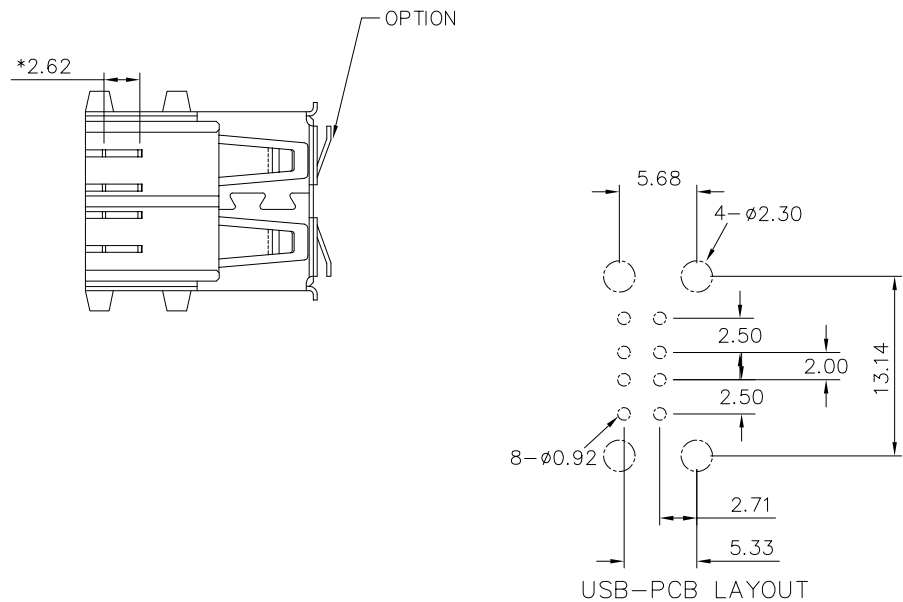

PART NO.	REV	PLATING	SHIELD TYPE	MATERIAL
E8144-11B024-L	C	Au 30u"	TIN LEAD (NO FRONT TAP)	A06-0080-L BACK

← MM (INCH) → TOLERANCES EXCEPT AS NOTED MM .0 ± 0.20 ± .00 ± 0.15 ± .000 ± 0.075 ±		DFTO LINGER	DATE 3/28/05		RoHS Compliant	
ANGLES ± 0.5° 		CHKD ALICE	DATE 10/13/2010		PULSE	
DETACHED LISTS THIRD ANGLE PROJECTION		APPVLLUSHENG	DATE 10/13/2010	TITLE		
FINISH : SCALE : 1:2		MATERIAL :		PULSE		
QTY :		DRAWING NO. E8144-1XXX2X-L2 /PART NO. E8144-1XXX2X-L2		USB A TYPE STACK		
DO NOT SCALE DRAWING		SHEET 1 OF 1		SIZE A3	REV 12	