

LOC	DIST	REVISIONS					
		P.	LTN	DESCRIPTION	DATE	DWN	APVD
CM	00	A		REVISED PER ECR 10-006756	01APR10	JR	SM
		B		REVISED PER ECR-18-000415	17JAN2018	RS	SZ

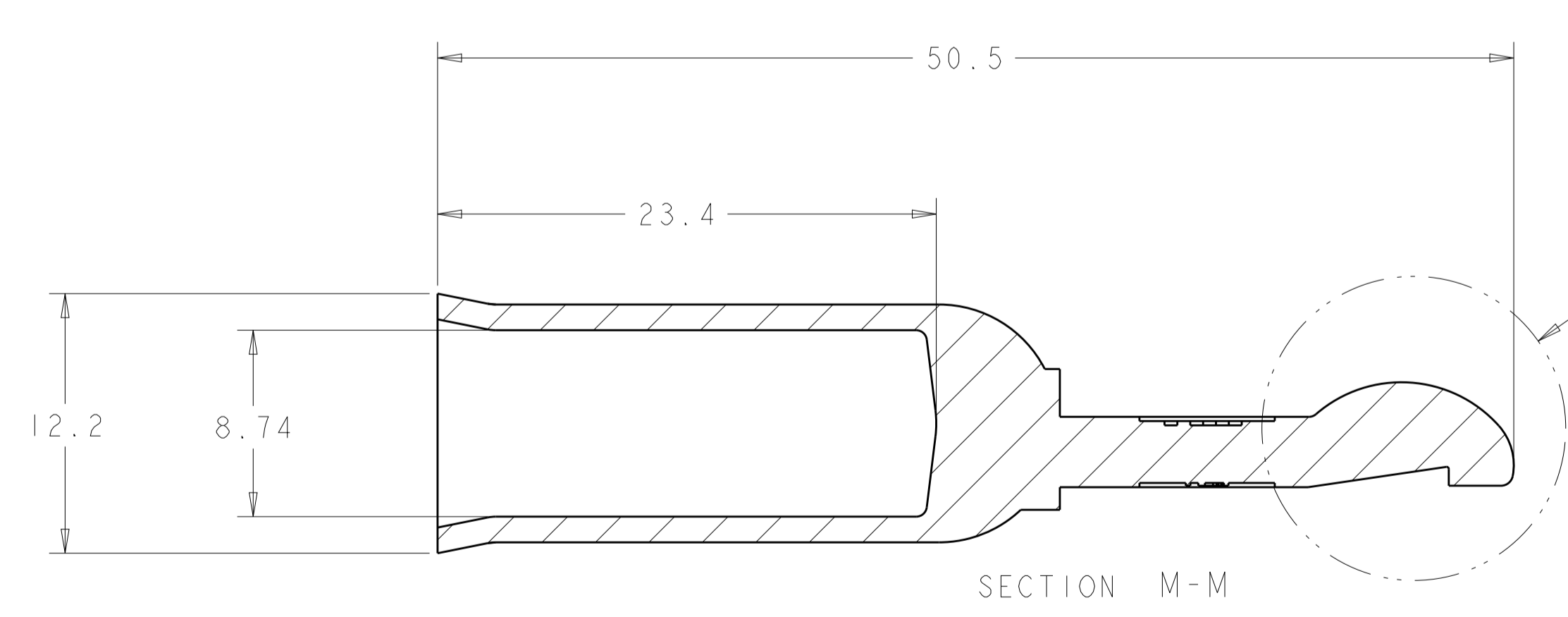
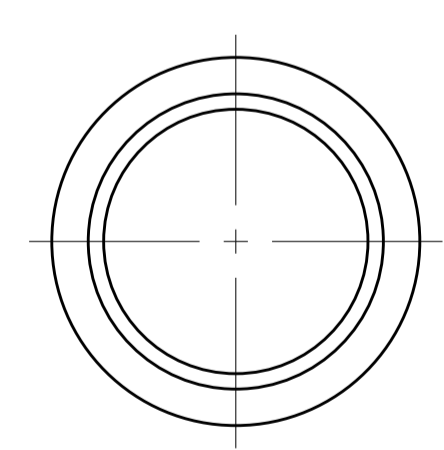
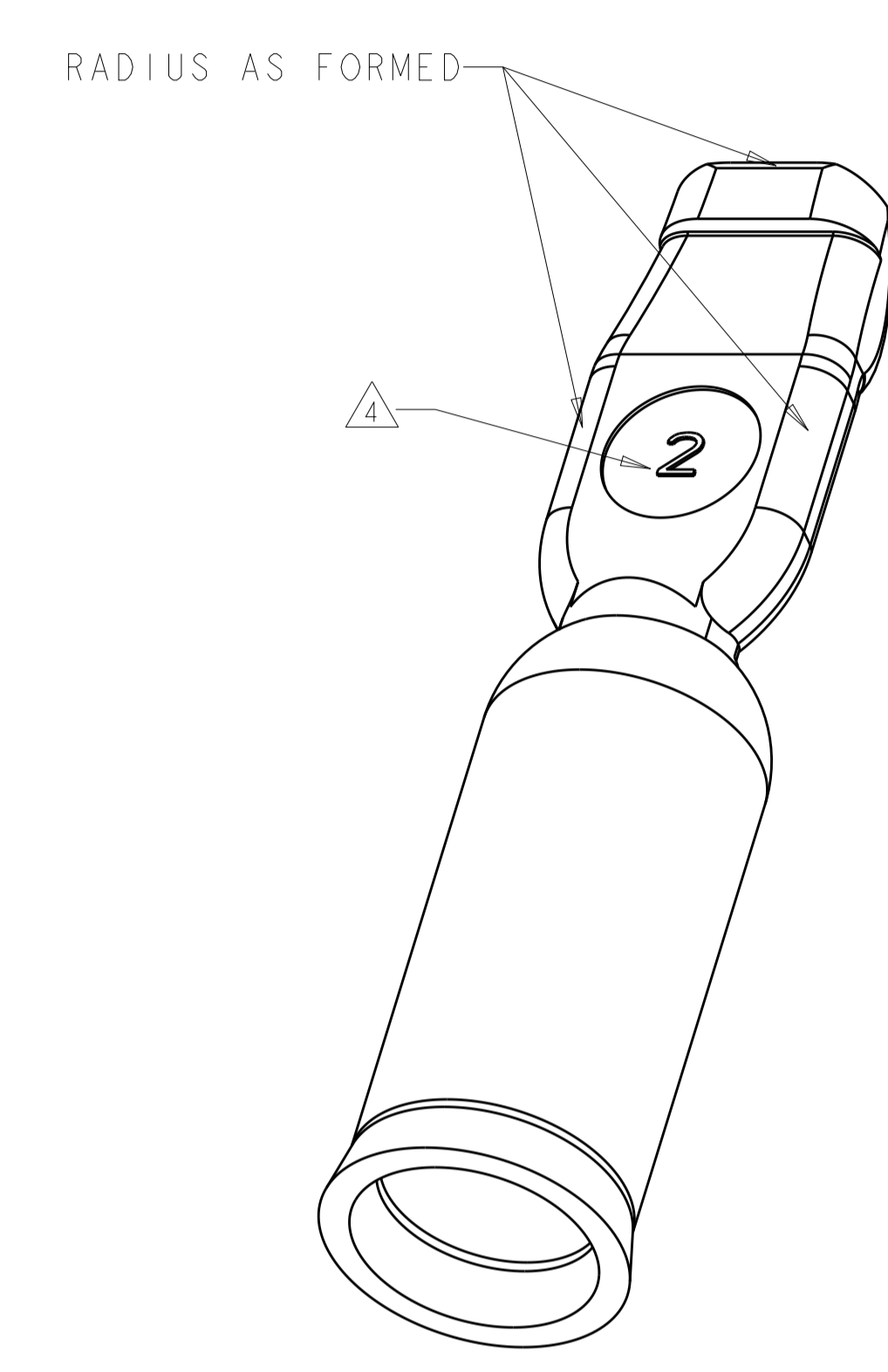
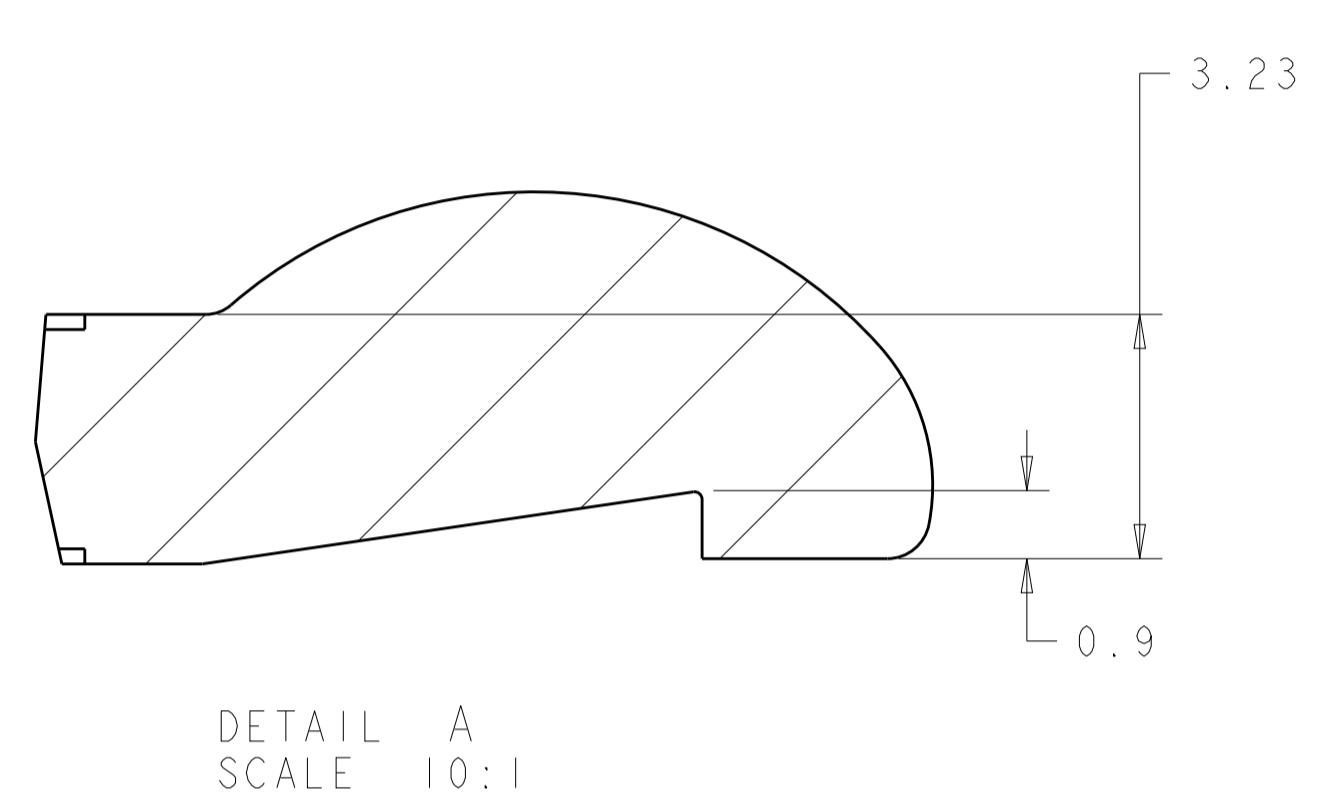
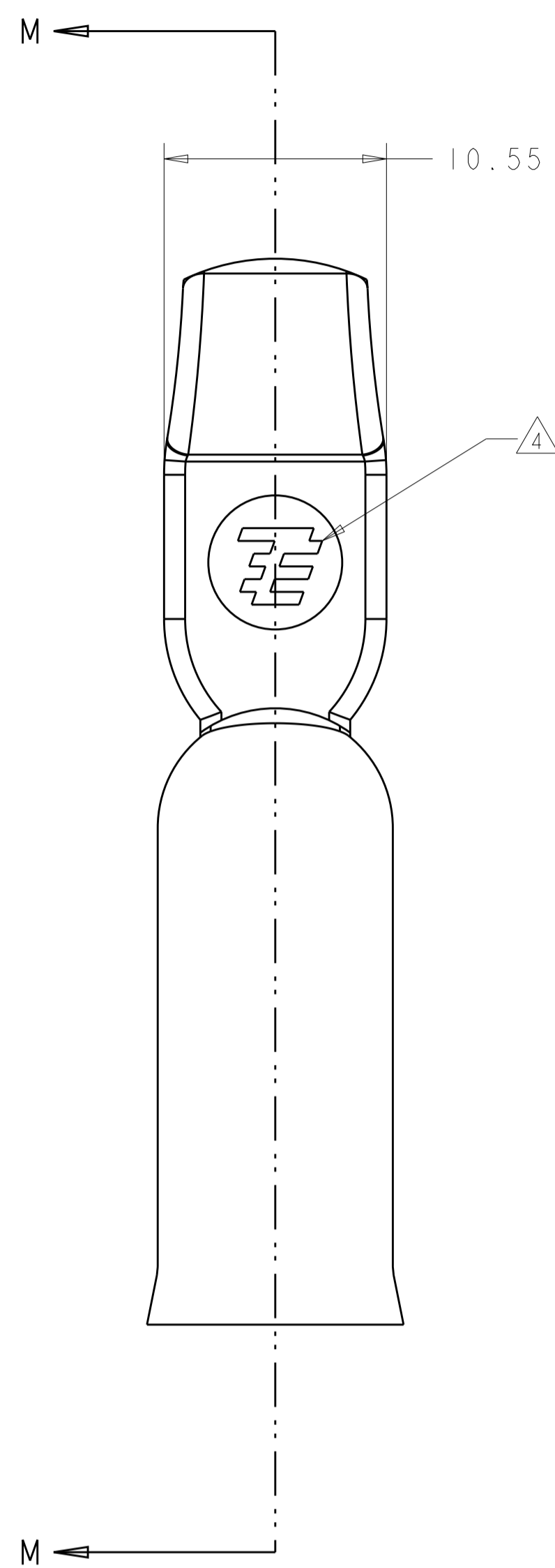

- SEE DETAIL A
1. MATERIAL: COPPER
  2. PLATING: SILVER
  3. THIS PRODUCT HAS PASSED VERIFICATION AND AGENCY APPROVALS TESTING AND IS COMPONENT RECOGNIZED PER UL 1977 AND CSA 22.2. TYCO ELECTRONICS PRODUCT QUALIFICATION TESTING IS NOT YET COMPLETED.
- 4 STAMP MARK MAY BE ROTATED

1445995-1  
PART NUMBER

METRIC

<small>THIS DRAWING IS UNPUBLISHED. RELEASED FOR PUBLICATION. IT IS THE POLICY OF TYCO ELECTRONICS CORPORATION TO CONTROL THE DISTRIBUTION OF THIS DRAWING. ANY UNAUTHORIZED REPRODUCTION OR DISSEMINATION OF THIS DRAWING TO ANY OTHER PERSON OR ORGANIZATION SHOULD BE CONTACTED FOR THE LATEST REVISION.</small>		DWN B. HAYMAKER 28NOV01 CHK K. KETELSLEGER 28NOV01 APVD K. KETELSLEGER 28NOV01	<b>tyco</b> Electronics Tyco Electronics Harrisburg, PA 17105-3608
DIMENSIONS: mm 	TOLERANCES UNLESS OTHERWISE SPECIFIED: 0 PLC ± 1 PLC ± 2 PLC ±0.13 3 PLC ± 4 PLC ± ANGLES ±5 FINISH	NAME PRODUCT SPEC APPLICATION SPEC WEIGHT CUSTOMER DRAWING	CONTACT, AMP POWER SERIES 120, 2 AWG SIZE CAGE CODE DRAWING NO A 00779 C=1445995 SCALE 4:1 SHEET 1 OF 1 REV B