

NC7SBU3157, FSAU3157

Low-Voltage SPDT Analog Switch or 2:1 Multiplexer / De-multiplexer Bus Switch

Features

- Analog and digital applications
- Space-saving, SC70 6-lead, surface-mount package
- Low on resistance: $<10\Omega$ on typical at 3.3V V_{CC}
- Broad V_{CC} operating range: 1.65V to 5.5V
- Rail-to-rail signal handling
- Power-down, high-impedance control input
- Over-voltage tolerance of control input to 7.0V
- Break-before-make enable circuitry
- 250 MHz, 3dB bandwidth

General Description

The NC7SBU3157 / FSAU3157 is a high-performance, single-pole / double-throw (SPDT) analog switch or 2:1 multiplexer / de-multiplexer bus switch.

The device is fabricated with advanced sub-micron CMOS technology to achieve high-speed enable and disable times and low on resistance. The break-before-make select circuitry prevents disruption of signals on the B port due to both switches temporarily being enabled during select pin switching. The device is specified to operate over the 1.65 to 5.5V V_{CC} operating range. The control input tolerates voltages up to 5.5V, independent of the V_{CC} operating range.

Fairchild's integrated Undershoot Hardened Circuit (UHC®) senses undershoot at the I/Os, and responds by preventing voltage differentials from developing and turning the switch on.

Ordering Information

Part Number	Top Mark	Operating Temperature Range	Eco Status	Package Description	Packing Method
NC7SBU3157P6X	U7A	-40 to +85°C	RoHS	6-Lead, SC70, EIAJ SC88, 1.25mm Wide Package	3000 Units Tape and Reel
FSAU3157P6X	U7A	-40 to +85°C	RoHS	6-Lead, SC70, EIAJ SC88, 1.25mm Wide Package	3000 Units Tape and Reel



For Fairchild's definition of Eco Status, please visit: http://www.fairchildsemi.com/company/green/rohs_green.html.

MicroPak™ is a trademark of Fairchild Semiconductor Corporation.

UHC® is a registered trademark of Fairchild Semiconductor Corporation.

Logic Symbol

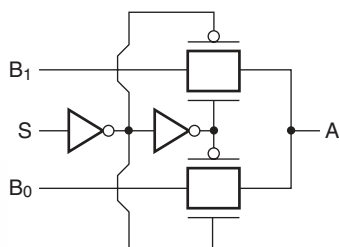
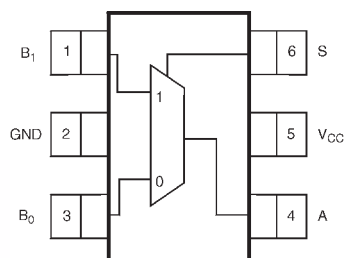

Figure 1. Logic Symbol

Connection Diagrams



2. Pin Assignments SC70

Analog Symbol

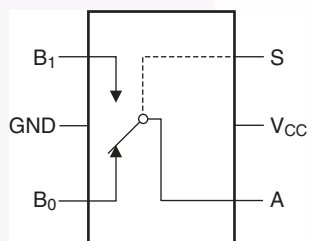

Figure 3. Analog Symbol

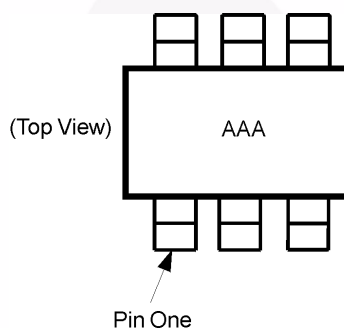

Figure 4. Pin One Orientation

Note:

Orientation of top mark determines pin one location. Read the top mark left to right and pin one is the lower left pin (see Figure 4).

Function Table

Input (S)	Function
Logic Level Low	B ₀ Connected to A
Logic Level High	B ₁ Connected to A

Pin Descriptions

Pin Names	Description
A, B ₀ , B ₁	Data Ports
S	Control Input

Absolute Maximum Ratings

Stresses exceeding the absolute maximum ratings may damage the device. The device may not function or be operable above the recommended operating conditions and stressing the parts to these levels is not recommended. In addition, extended exposure to stresses above the recommended operating conditions may affect device reliability. The absolute maximum ratings are stress ratings only

Symbol	Parameter	Min.	Max.	Units
V_{CC}	Supply Voltage	-0.5	+7.0	V
V_S	DC Switch Voltage ⁽¹⁾	-0.5	$V_{CC} + 0.5$	V
V_{IN}	DC Input Voltage ⁽¹⁾	-0.5	+7.0	V
I_{IK}	DC Input Diode Current at $V_{IN} < 0V$		-50	mA
I_{OUT}	DC Output Current		128	mA
I_{CC}/I_{GND}	DC V_{CC} or Ground Current		±100	mA
T_{STG}	Storage Temperature Range	-65	+150	°C
T_J	Junction Temperature Under Bias		+150	°C
T_L	Junction Lead Temperature (Soldering, 10 seconds)		+260	°C
P_D	Power Dissipation at +85°C		180	mW

Note:

1. The input and output negative voltage ratings may be exceeded if the input and output diode current ratings are observed.

Recommended Operating Conditions

The Recommended Operating Conditions table defines the conditions for actual device operation. Recommended operating conditions are specified to ensure optimal performance to the datasheet specifications. Fairchild does not recommend exceeding them or designing to absolute maximum ratings.

Symbol	Parameter	Min.	Max	Units	
V_{CC}	Supply Voltage Operating	1.65	5.50	V	
V_{IN}	Control Input Voltage ⁽²⁾	0	V_{CC}	V	
V_{IN}	Switch Input Voltage ⁽²⁾	0	V_{CC}	V	
V_{OUT}	Output Voltage ⁽²⁾	0	V_{CC}	V	
T_A	Operating Temperature	-40	+85	°C	
t_r, t_f	Input Rise and Fall Time	Control Input $V_{CC}=2.3V-3.6V$	0	10	ns/V
		Control Input $V_{CC}=4.5V-5.5V$	0	5	ns/V
θ_{JA}	Thermal Resistance		350	°C/W	

Note:

2. Control input must be held HIGH or LOW; it must not float.

DC Electrical Characteristics

Symbol	Parameter	Conditions	V _{CC} (V)	T _A = +25°C			T _A = -40°C to +85°C		Units
				Min.	Typ.	Max.	Min.	Max.	
V _{IH}	High Level Input Voltage		1.65 to 1.95	0.75 V _{CC}			0.75 V _{CC}		V
			2.3 to 5.5	0.7 V _{CC}			0.7 V _{CC}		
V _{IL}	Low Level Input Voltage		1.65 to 1.95			0.25 V _{CC}		0.25 V _{CC}	V
			2.3 to 5.5			0.3 V _{CC}		0.3 V _{CC}	
I _{IN}	Input Leakage Current	0 ≤ V _{IN} ≤ 5.5V	0 to 5.5		±0.05	±0.1		±1	μA
I _{OFF}	Off State Leakage Current	0 ≤ A, B ≤ V _{CC}	1.65 to 5.5		±0.05	±0.1		±1	μA
R _{ON}	Switch On Resistance ⁽³⁾	V _{IN} =0V, I _O =30mA	4.5			3.0		15.0	Ω
		V _{IN} =2.4V, I _O =-30mA				5.0		15.0	
		V _{IN} =4.5V, I _O =-30mA				7.0		15.0	
		V _{IN} =0V, I _O =24mA	3.0			4.0		20.0	
		V _{IN} =3V, I _O =-24mA				10.0		20.0	
		V _{IN} =0V, I _O =8mA	2.3			5.0		30.0	
		V _{IN} =2.3V, I _O =-8mA				13.0		30.0	
		V _{IN} =0V, I _O =4mA	1.65			6.5		50.0	
V _{IN} =1.65V, I _O =-4mA				17.0		50.0			
I _{CC}	Quiescent Supply Current; All Channels On or Off	V _{IN} =V _{CC} or GND I _{OUT} =0	5.5			1		10	μA
	Analog Signal Range		V _{CC}	0		V _{CC}	0	V _{CC}	V
R _{RANGE}	On Resistance Over Signal Range ^(3, 7)	I _A =-30mA, 0 ≤ V _{Bn} ≤ V _{CC}	4.5					25.0	Ω
		I _A =-24mA, 0 ≤ V _{Bn} ≤ V _{CC}	3.0				50.0		
		I _A =-8mA, 0 ≤ V _{Bn} ≤ V _{CC}	2.3				100		
		I _A =-4mA, 0 ≤ V _{Bn} ≤ V _{CC}	1.65				300		
ΔR _{ON}	On Resistance Match Between-Channels ^(3, 4, 5)	I _A =-30mA, V _{Bn} =3.15	4.5		0.15			Ω	
		I _A =-24mA, V _{Bn} 2.1	3.0		0.2				
		I _A =-8mA, V _{Bn} =1.6	2.3		0.5				
		I _A =-4mA, V _{Bn} =1.15	1.65		0.5				
V _{IKU}	Voltage Under-shoot	0.0mA ≤ I _{IN} ≤ -50, OE 5.5v	5.5					-2	V
R _{flat}	On Resistance Flatness ^(3, 4, 6)	I _A =-30mA, 0 ≤ V _{Bn} ≤ V _{CC}	5.0		6.0			Ω	
		I _A =-24mA, 0 ≤ V _{Bn} ≤ V _{CC}	3.3		12.0				
		I _A =-8mA, 0 ≤ V _{Bn} ≤ V _{CC}	2.5		28.0				
		I _A =-4mA, 0 ≤ V _{Bn} ≤ V _{CC}	1.8		125				

Notes:

- Measured by the voltage drop between A and B pins at the indicated current through the switch. On resistance is determined by the lower of the voltages on the two (A or B Ports).
- Parameter is characterized, but not tested in production.
- ΔR_{ON} = R_{ON} max – R_{ON} minimum measured at identical V_{CC}, temperature, and voltage levels.
- Flatness is defined as the difference between the maximum and minimum value of on resistance over the specified range of conditions.
- Guaranteed by design.

AC Electrical Characteristics

Symbol	Parameter	Conditions	V _{CC} (V)	T _A = +25°C			T _A = -40°C to +85°C		Units	Figure
				Min.	Typ.	Max.	Min.	Max.		
t _{PHL} , t _{PLH}	Propagation Delay Bus-to-Bus ⁽⁸⁾	V _I = OPEN	1.65 to 1.95					ns	Figure 7 Figure 8	
			2.3 to 2.7			1.2	1.2			
			3.0 to 3.6			0.8	0.8			
			4.5 to 5.5			0.3	0.3			
t _{PZL} , t _{PZH}	Output Enable Time Turn-On Time (A to B _n)	V _I = 2 x V _{CC} for t _{PZL} V _I = 0V for t _{PZH}	1.65 to 1.95	7.0		23.0	7.0	ns	Figure 7 Figure 8	
			2.3 to 2.7	3.5		13.0	3.5			14.0
			3.0 to 3.6	2.5		6.9	2.5			7.6
			4.5 to 5.5	1.7		5.2	1.7			5.7
t _{PLZ} , t _{PHZ}	Output Disable Time Turn-Off Time (A Port to B Port)	V _I = 2 x V _{CC} for t _{PLZ} V _I = 0V for t _{PHZ}	1.65 to 1.95	3.0		12.5	3.0	ns	Figure 7 Figure 8	
			2.3 to 2.7	2.0		7.0	2.0			7.5
			3.0 to 3.6	1.5		5.0	1.5			5.3
			4.5 to 5.5	0.8		3.5	0.8			3.8
t _{BBM}	Break-Before-Make Time ⁽⁹⁾		1.65 to 1.95	0.5		0.5		ns	Figure 9	
			2.3 to 2.7	0.5		0.5				
			3.0 to 3.6	0.5		0.5				
			4.5 to 5.5	0.5		0.5				
Q	Charge Injection ⁽⁹⁾	C _L = 0.1nF, V _{GEN} = 0V,	5.0		7.0		pC	Figure 10		
		R _{GEN} = 0Ω	3.3		3.0					
OIRR	Off Isolation ⁽¹⁰⁾	R _L = 50Ω, f = 10MHz	1.65 to 5.5		-57.0		dB	Figure 11		
Xtalk	Crosstalk	R _L = 50Ω, f = 10MHz	1.65 to 5.5		-54.0		dB	Figure 12		
BW	-3dB Bandwidth	R _L = 50Ω	1.65 to 5.5		250		MHz	Figure 15		
THD	Total Harmonic Distortion ⁽⁹⁾	R _L = 600Ω, 0.5V _{PP} , f = 20Hz to 20KHz	5.0		.011		%			

Notes:

8. This parameter is guaranteed by design but not tested. The bus switch contributes no propagation delay other than the RC delay of the on resistance of the switch and the 50pF load capacitance, when driven by an ideal voltage source (zero output impedance).
9. Guaranteed by design.
10. Off Isolation = 20 log₁₀ [V_A / V_{Bn}].

Capacitance

T_A = +25°C, f = 1MHz. Capacitance is characterized, but not tested in production.

Symbol	Parameter	Conditions	Typ.	Max.	Units	Figure
C _{IN}	Control Pin Input Capacitance	V _{CC} = 0V	2.3		pF	
C _{IO-B}	B Port Off Capacitance	V _{CC} = 5.0V	6.5		pF	Figure 13
C _{IOA-ON}	A Port Capacitance When Switch Is Enabled	V _{CC} = 5.0V	18.5		pF	Figure 14

Undershoot Characteristic

Symbol	Parameter	Min.	Typ.	Units	Figure
V_{OUTU}	Output Voltage During Undershoot	2.5	$V_{OH} - 0.3$	V	Figure 5

Note:

11. This test is intended to characterize the device's protective capabilities by maintaining output signal integrity during an input transient voltage undershoot event.

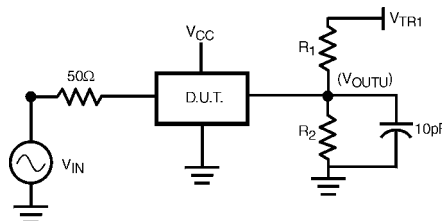

Figure 5. Output Voltage During Undershoot

Device Test Conditions

Parameter	Value	Units
V_{IN}	see Figure 6	V
$R_1 = R_2$	100	K Ω
V_{TRI}	7.0	V
V_{CC}	5.5	V

Transient Input Voltage (V_{IN}) Waveform

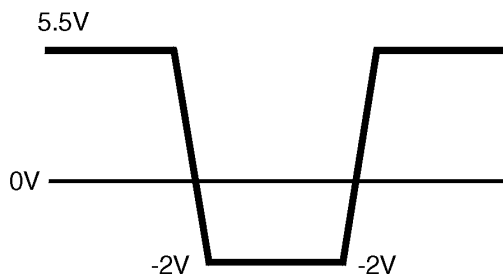
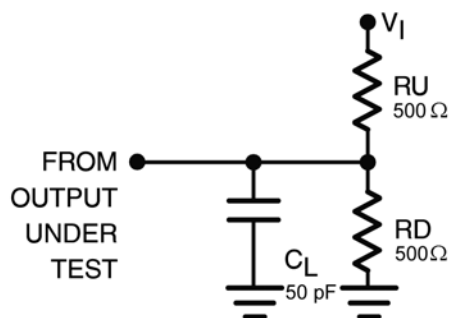

Figure 6. Transient Input Voltage Waveform

AC Loading and Waveforms



Notes:
 Input driven by 50Ω source terminated in 50Ω.
 C_L includes load and stray capacitance.
 Input PRR=1.0MHz; $t_w = 500\text{ns}$.

Figure 7. AC Test Circuit

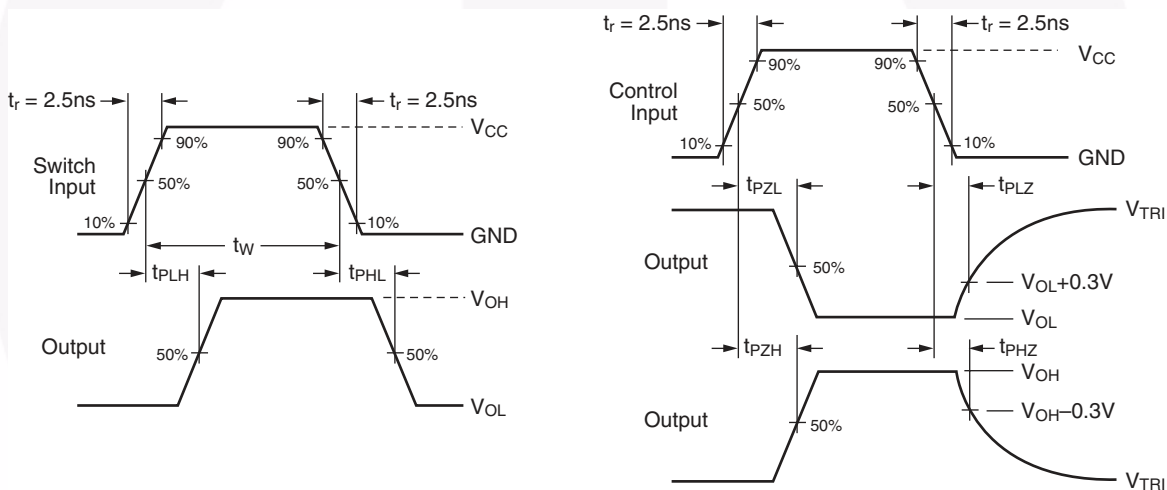

Figure 8. AC Waveforms

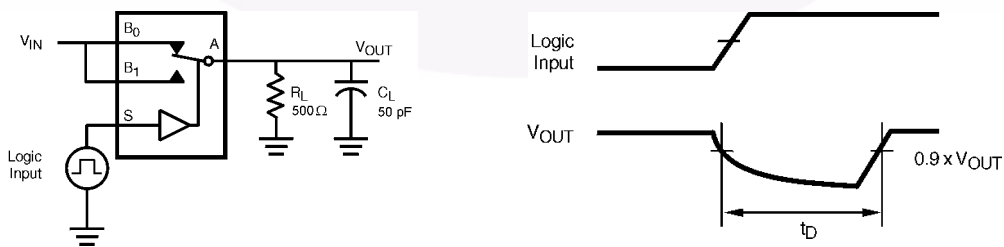

Figure 9. Break-Before-Make Interval Timing

AC Loading and Waveforms (continued)

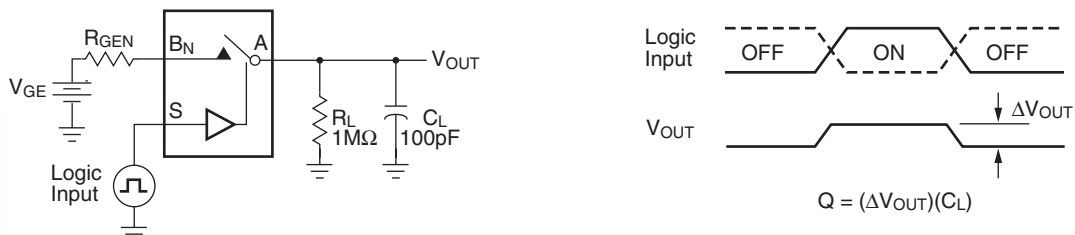

Figure 10. Charge Injection Test

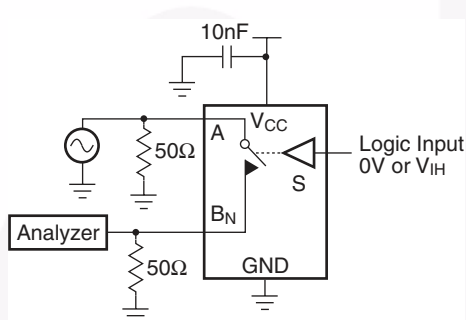

Figure 11. Off Isolation

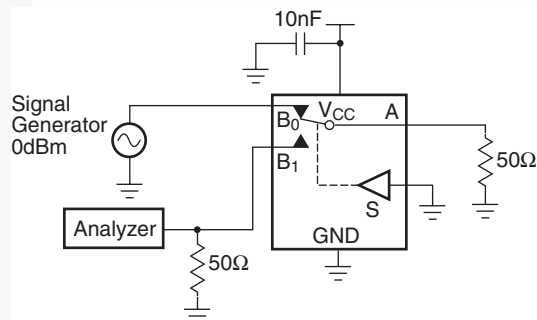

Figure 12. Crosstalk

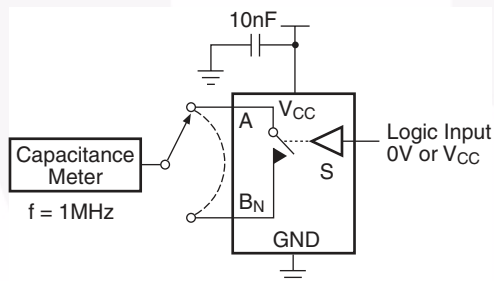

Figure 13. Channel Off Capacitance

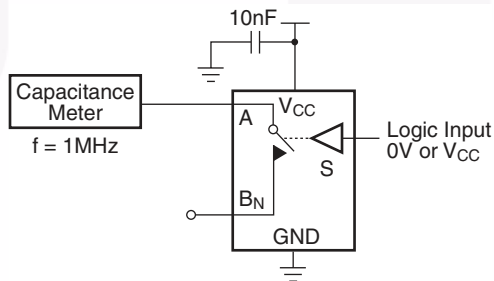

Figure 14. Channel On Capacitance

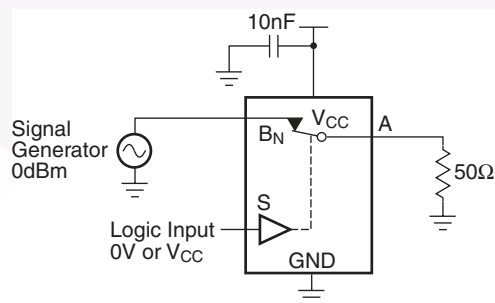
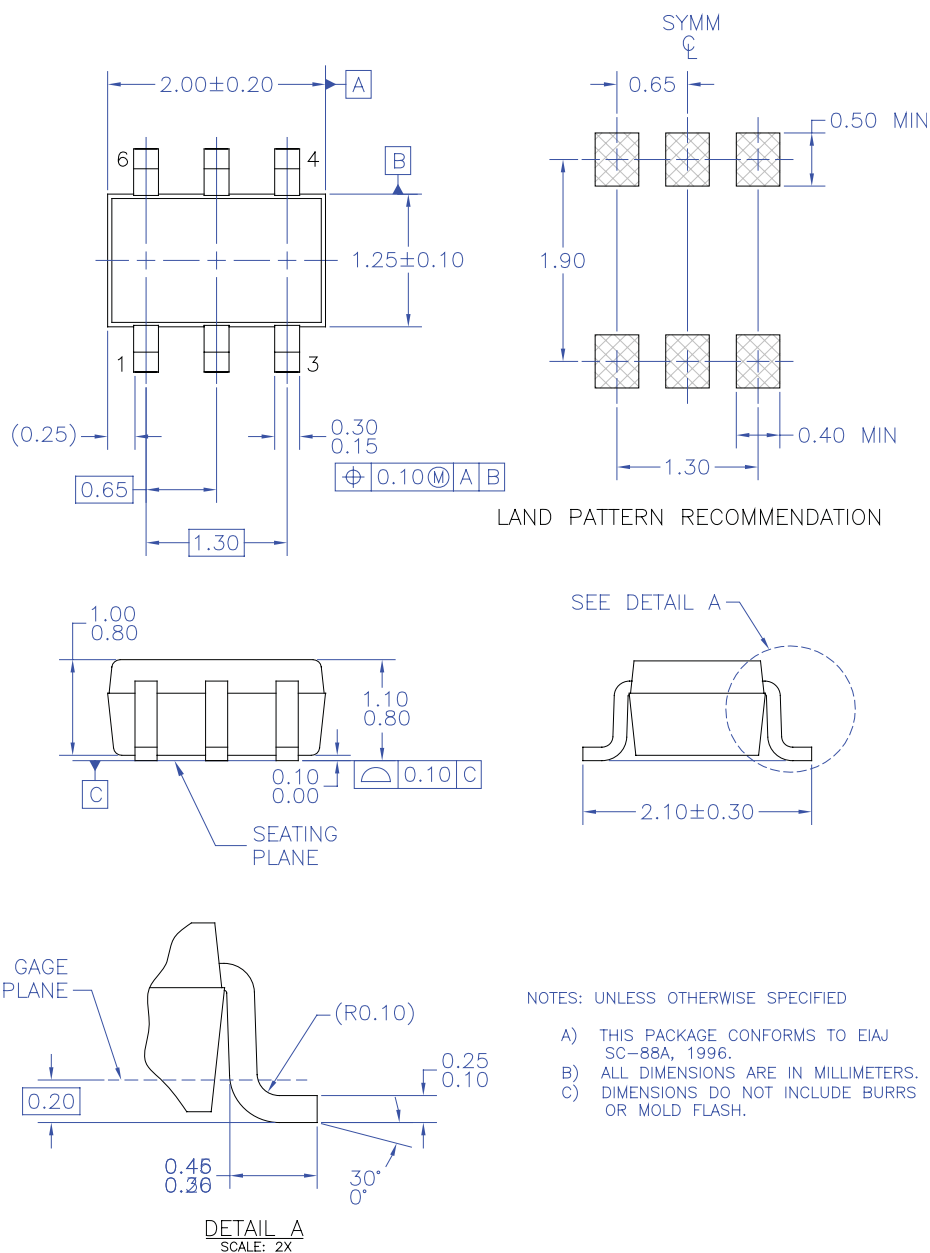

Figure 15. Bandwidth

Physical Dimensions



VAA06ARFV5

Figure 16. 6-Lead, SC70, EIAJ SC88, 1.25mm Wide Package

Package drawings are provided as a service to customers considering Fairchild components. Drawings may change in any manner without notice. Please note the revision and/or date on the drawing and contact a Fairchild Semiconductor representative to verify or obtain the most recent revision. Package specifications do not expand the terms of Fairchild's worldwide terms and conditions, specifically the warranty therein, which covers Fairchild products.

Always visit Fairchild Semiconductor's online packaging area for the most recent package drawings:

<http://www.fairchildsemi.com/packaging/>







For SC70 Tape and Reel Specifications, please visit:

http://www.fairchildsemi.com/products/analog/pdf/sc70-6_tr.pdf



TRADEMARKS

The following includes registered and unregistered trademarks and service marks, owned by Fairchild Semiconductor and/or its global subsidiaries, and is not intended to be an exhaustive list of all such trademarks.

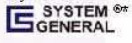
- | | | | |
|---|---|---|---|
| Auto-SPM™ | F-PFS™ | PowerTrench® | The Power Franchise® |
| Build it Now™ | FRFET® | PowerXS™ |  |
| CorePLUS™ | Global Power Resource™ | Programmable Active Droop™ | TinyBoost™ |
| CorePOWER™ | Green FPS™ | QFET® | TinyBuck™ |
| CROSSVOLT™ | Green FPS™ e-Series™ | QS™ | TinyLogic® |
| CTL™ | Gmax™ | Quiet Series™ | TINYOPTO™ |
| Current Transfer Logic™ | GTO™ | RapidConfigure™ | TinyPower™ |
| EcoSPARK® | IntelliMAX™ |  | TinyPWM™ |
| EfficientMax™ | ISOPLANAR™ | Saving our world, 1mW/WKw at a time™ | TinyWire™ |
| EZSWITCH™ | MegaBuck™ | SmartMax™ | TriFault Detect™ |
|  | MICROCOUPLER™ | SMART START™ | TRUECURRENT™ |
|  | MicroFET™ | SPM® | μSerDes™ |
| Fairchild® | MicroPak™ | STEALTH™ |  |
| Fairchild Semiconductor® | MillerDrive™ | SuperFET™ | UHC® |
| FACT Quiet Series™ | MotionMax™ | SuperSOT™3 | Ultra FRFET™ |
| FACT® | Motion-SPM™ | SuperSOT™6 | UniFET™ |
| FAST® | OPTOLOGIC® | SuperSOT™8 | VCX™ |
| FastvCore™ | OPTOPLANAR® | SupreMOS™ | VisualMax™ |
| FETBench™ |  | SyncFET™ | XST™ |
| FlashWriter® | PDP SPM™ | Sync-Lock™ | |
| FPS™ | Power-SPM™ |  | |

* Trademarks of System General Corporation, used under license by Fairchild Semiconductor.

DISCLAIMER

FAIRCHILD SEMICONDUCTOR RESERVES THE RIGHT TO MAKE CHANGES WITHOUT FURTHER NOTICE TO ANY PRODUCTS HEREIN TO IMPROVE RELIABILITY, FUNCTION, OR DESIGN. FAIRCHILD DOES NOT ASSUME ANY LIABILITY ARISING OUT OF THE APPLICATION OR USE OF ANY PRODUCT OR CIRCUIT DESCRIBED HEREIN; NEITHER DOES IT CONVEY ANY LICENSE UNDER ITS PATENT RIGHTS, NOR THE RIGHTS OF OTHERS. THESE SPECIFICATIONS DO NOT EXPAND THE TERMS OF FAIRCHILD'S WORLDWIDE TERMS AND CONDITIONS, SPECIFICALLY THE WARRANTY THEREIN, WHICH COVERS THESE PRODUCTS.

LIFE SUPPORT POLICY

FAIRCHILD'S PRODUCTS ARE NOT AUTHORIZED FOR USE AS CRITICAL COMPONENTS IN LIFE SUPPORT DEVICES OR SYSTEMS WITHOUT THE EXPRESS WRITTEN APPROVAL OF FAIRCHILD SEMICONDUCTOR CORPORATION.

As used herein:

1. Life support devices or systems are devices or systems which, (a) are intended for surgical implant into the body or (b) support or sustain life, and (c) whose failure to perform when properly used in accordance with instructions for use provided in the labeling, can be reasonably expected to result in a significant injury of the user.
2. A critical component in any component of a life support, device, or system whose failure to perform can be reasonably expected to cause the failure of the life support device or system, or to affect its safety or effectiveness.

ANTI-COUNTERFEITING POLICY

Fairchild Semiconductor Corporation's Anti-Counterfeiting Policy. Fairchild's Anti-Counterfeiting Policy is also stated on our external website, www.fairchildsemi.com, under Sales Support.

Counterfeiting of semiconductor parts is a growing problem in the industry. All manufacturers of semiconductor products are experiencing counterfeiting of their parts. Customers who inadvertently purchase counterfeit parts experience many problems such as loss of brand reputation, substandard performance, failed applications, and increased cost of production and manufacturing delays. Fairchild is taking strong measures to protect ourselves and our customers from the proliferation of counterfeit parts. Fairchild strongly encourages customers to purchase Fairchild parts either directly from Fairchild or from Authorized Fairchild Distributors who are listed by country on our web page cited above. Products customers buy either from Fairchild directly or from Authorized Fairchild Distributors are genuine parts, have full traceability, meet Fairchild's quality standards for handling and storage and provide access to Fairchild's full range of up-to-date technical and product information. Fairchild and our Authorized Distributors will stand behind all warranties and will appropriately address any warranty issues that may arise. Fairchild will not provide any warranty coverage or other assistance for parts bought from Unauthorized Sources. Fairchild is committed to combat this global problem and encourage our customers to do their part in stopping this practice by buying direct or from authorized distributors.

PRODUCT STATUS DEFINITIONS

Definition of Terms

Datasheet Identification	Product Status	Definition
Advance Information	Formative / In Design	Datasheet contains the design specifications for product development. Specifications may change in any manner without notice.
Preliminary	First Production	Datasheet contains preliminary data; supplementary data will be published at a later date. Fairchild Semiconductor reserves the right to make changes at any time without notice to improve design.
No Identification Needed	Full Production	Datasheet contains final specifications. Fairchild Semiconductor reserves the right to make changes at any time without notice to improve the design.
Obsolete	Not In Production	Datasheet contains specifications on a product that is discontinued by Fairchild Semiconductor. The datasheet is for reference information only.

Rev. I40