

AG903-07E

TDFN Current Sensor Evaluation Board

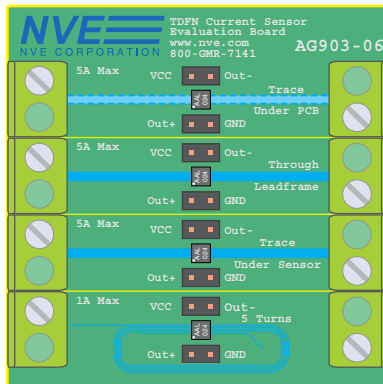

SB-00-069B

Overview

This Evaluation Board Includes

- Four AAL024-10E TDFN current sensors
- 2" x 2" (50 mm x 50 mm) PCB with four different current-trace configurations
- PCB screw connections for 14 to 30 AWG wire
- Up to 5 amp AC or DC noncontact current measurement

AAL024-10E Features

- Wheatstone bridge analog outputs
- High sensitivity: 3.6 mV/V/Oe typical
- Wide linear range: 1.5 – 10.5 Oe; 15 Oe saturation
- 2.2 k Ω bridge resistance/1.1 k Ω output impedance for easy interface
- Low offset: 4 mV/V max.
- Low hysteresis: 2% max. for excellent repeatability
- Wide bandwidth: 100 kHz
- 63 V minimum inherent isolation (pad to electrical connections)
- Ultraminiature 2.5 mm x 2.5 mm TDFN6 package

Advantages of Sensing Current Over Trace

- Negligible insertion resistance
- Usable for a wide current range
- Inherent electrical isolation
- AC or DC operation

Additional Resources

- Analog Sensor Selector Guide: www.nve.com/analogSensors.php
 - Analog Sensor Datasheets: www.nve.com/Downloads/analog_catalog.pdf
 - Current-Sensing Web Application:
www.nve.com/spec/calculators.php#tabs-Current-Sensing
 - Reference Designs: <https://www.nve.com/sensor-reference.php>
 - Videos: www.nve.com/Videos.php ; www.YouTube.com/NveCorporation
 - Buy Online: www.nve.com/webstore/catalog
-

Quick Start

- ⇒ Connect V_{CC} and GND for a sensor to a power supply (12V max.) or a battery.
- ⇒ Connect the sensor “Out+” and “Out-” to a meter.
- ⇒ Connect an AC or DC current via the screw terminals (22-gauge wire can be used for up to 7A).
- ⇒ Compare the sensor output to the circuit-board trace current.

Four Configurations

The evaluation board demonstrates four current-trace configurations:

A. *Trace under PCB*

This is the least sensitive configuration because of the distance between the sensor from the trace, but it provides excellent electrical isolation since the circuit board separates the sensor and trace. The PCB is a standard 0.062-inch thick (1.6 mm). The 0.05-inch (1.25 mm) wide trace of one-ounce copper can carry up to about five amps with a 30°C temperature rise.

B. *Sensor soldered to trace on top side of PCB*

The current-carrying trace is on the top side of the PCB, closer to the sensor, and the center pad is soldered to the trace. Soldering the center pad increases mechanical strength, but since the pad is connected to the leadframe, electrical isolation is reduced to the sensor itself. The sensor provides a minimum of 63 volts isolation from the pad to the sensor electrical connections.

C. *Sensor over trace on top side of PCB (center pad insulated from trace)*

The solder mask insulates the trace from the sensor center pad, which generally provides enough isolation for line voltage operation.

D. *Five turns on top side of PCB*

Five traces provide approximately five times the field, but they must be narrower to fit under the sensor, limiting the current to approximately one amp for the 0.0055-inch (0.14 mm) wide traces.

Typical characteristics of the configurations are summarized as follows:

Configuration	Max. Current	Sensitivity	Saturation	Isolation
A. Trace under PCB	5 A	4 mV/V/A	15 A	>6 kV
B. Center pad soldered	5 A	12 mV/V/A	5 A	63V
C. Trace on top of PCB	5 A	12 mV/V/A	5 A	>300V
D. 5 turns on top of PCB	1 A	60 mV/V/A	1 A	>300V

Evaluation Board Layout (2x Actual Size)

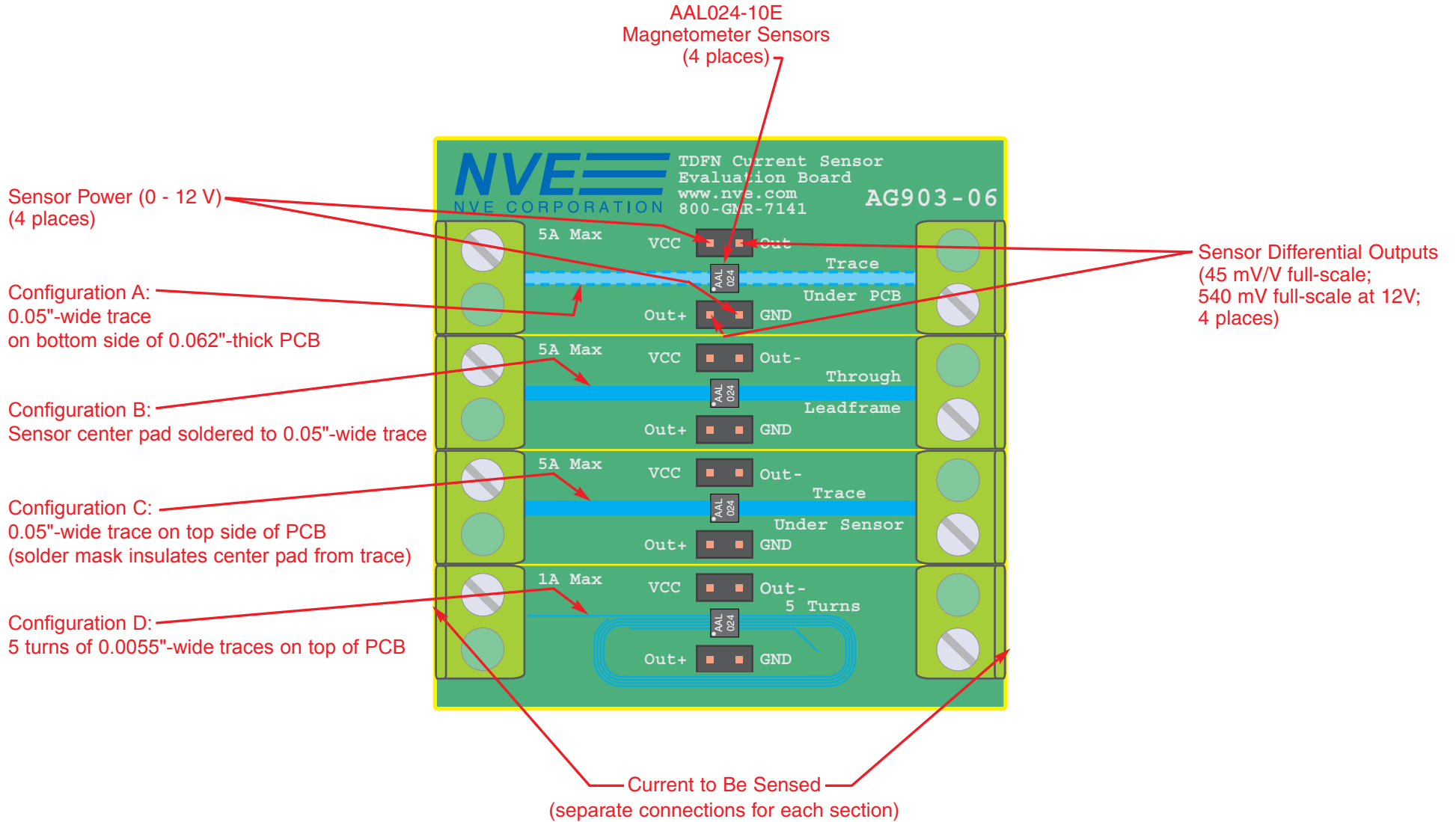

Principles of Operation

Current through a circuit-board trace will produce a magnetic field proportional to the current, in a direction at a right angle to the trace:

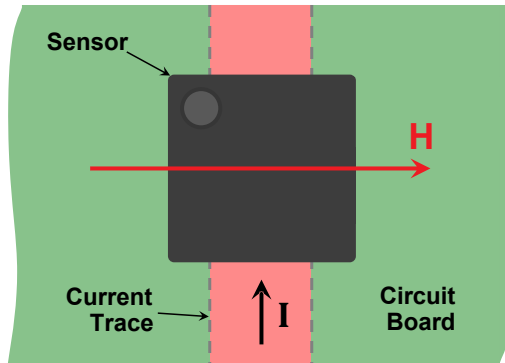

Current sensing over a circuit-board trace.

The AAL024 sensor has cross-axis sensitivity to detect this field orientation. The sensor is a Wheatstone bridge, which produces a differential output proportional to the field and the power supply:

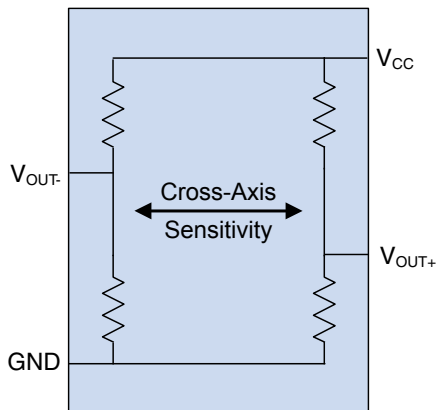

AAL024-10E Wheatstone bridge configuration.

Since the output is proportional to field and supply, sensitivity is generally expressed as mV/V/Oe for field or mV/V/A for current.

Sensors Details

Omnipolar Response

AA-Series sensors are “omnipolar,” meaning the output voltage is positive for either field polarity. This produces an output analogous to half-wave rectification of the current being sensed, eliminating the need for rectification of AC inputs.

Bridge Offset

The sensors have a maximum offset of ± 4 mV/V. This can be trimmed out with an external resistor if necessary.

Temperature Compensation

The Wheatstone bridge inherently compensates for temperature changes, but there is still some residual temperature coefficient. A constant-current rather than constant-voltage power supply reduces the temperature coefficient of the output considerably. The sensors can also be externally temperature compensated if necessary.

Ampere’s Law

For narrow traces, the magnetic field generated can be approximated by Ampere’s law:

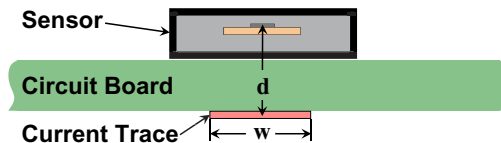

$$B = \frac{2I}{d} \text{ [“B” in Gauss, “I” in amps, and “d” in millimeters]}$$

A more accurate calculation can be made by breaking the trace into a finite-element array of thin traces, and calculating the field from each array element.

We have a free, Web-based application with a finite-element model to estimate magnetic fields and sensor outputs in this application:

www.nve.com/spec/calculators.php#tabs-Current-Sensing

Limited Warranty and Liability

Information in this document is believed to be accurate and reliable. However, NVE does not give any representations or warranties, expressed or implied, as to the accuracy or completeness of such information and shall have no liability for the consequences of use of such information. In no event shall NVE be liable for any indirect, incidental, punitive, special or consequential damages (including, without limitation, lost profits, lost savings, business interruption, costs related to the removal or replacement of any products or rework charges) whether or not such damages are based on tort (including negligence), warranty, breach of contract or any other legal theory.

Right to Make Changes

NVE reserves the right to make changes to information published in this document including, without limitation, specifications and product descriptions at any time and without notice.

Use in Life-Critical or Safety-Critical Applications

Unless NVE and a customer explicitly agree otherwise in writing, NVE products are not designed, authorized or warranted to be suitable for use in life support, life-critical or safety-critical devices or equipment. NVE accepts no liability for inclusion or use of NVE products in such applications and such inclusion or use is at the customer's own risk. Should the customer use NVE products for such application whether authorized by NVE or not, the customer shall indemnify and hold NVE harmless against all claims and damages.

Applications

Applications described in this document are illustrative only. NVE makes no representation or warranty that such applications will be suitable for the specified use without further testing or modification. Customers are responsible for the design and operation of their applications and products using NVE products, and NVE accepts no liability for any assistance with applications or customer product design. It is customer's sole responsibility to determine whether the NVE product is suitable and fit for the customer's applications and products planned, as well as for the planned application and use of customer's third party customers. Customers should provide appropriate design and operating safeguards to minimize the risks associated with their applications and products. NVE does not accept any liability related to any default, damage, costs or problem which is based on any weakness or default in the customer's applications or products, or the application or use by customer's third party customers. The customer is responsible for all necessary testing for the customer's applications and products using NVE products in order to avoid a default of the applications and the products or of the application or use by customer's third party customers. NVE accepts no liability in this respect.

An ISO 9001 Certified Company

NVE Corporation
11409 Valley View Road
Eden Prairie, MN 55344-3617

©NVE Corporation

All rights are reserved. Reproduction in whole or in part is prohibited without the prior written consent of the copyright owner.

Manual No.: SB-00-069