

ABSTRACT

This user's guide provides information on the correct usage of the test board and an explanation of the test points and jumpers on the board. The test board features the MYC0409-NA configured for Divide by Four operation. The test board operates over the entire input voltage range of the MYC0409-NA. The minimum input and the output capacitors are included on the board.

Table of Contents

Description	2	Performance Data	6
Performance summary	2	MYC0409 EVM Bill of Materials (BOM).....	9
Quick Start Guide	3	MYC0409 EVM Schematic	9
Evaluation overview.....	3	EVM PCB Layout	9
Terminal functions and Jumper settings.....	4	Notices.....	10
Power Input and Output Descriptions	4	 CAUTION	10
Test Point Descriptions	4	Sales Contact.....	10
Jumper Descriptions.....	4	Disclaimers	10
EVM connection	5	Copyright and Trademark.....	10
Start-Up Procedure	5		

Description

This EVM features the MYC0409-NA standalone charge pump module configured for operation with 20 to 60V input voltage range. The output voltage is fixed divide-by-4 conversion ratio from input voltage. A synchronize with an external clock can be set with a jumper. The full output current rating of the device can be supplied by the EVM.

Input and output capacitors are mounted on the board to accommodate the entire range of input and output voltages. Monitoring test points are provided to allow measurement of voltage, efficiency, power dissipation and load regulation.

Control jumpers and component footprints are provided for use of the ENABLE, PGOOD, and CLK features of the module. The EVM uses a recommended PCB layout that minimizes output ripple and noise. Detailed application information for MYC0409-NA is available in the datasheet.

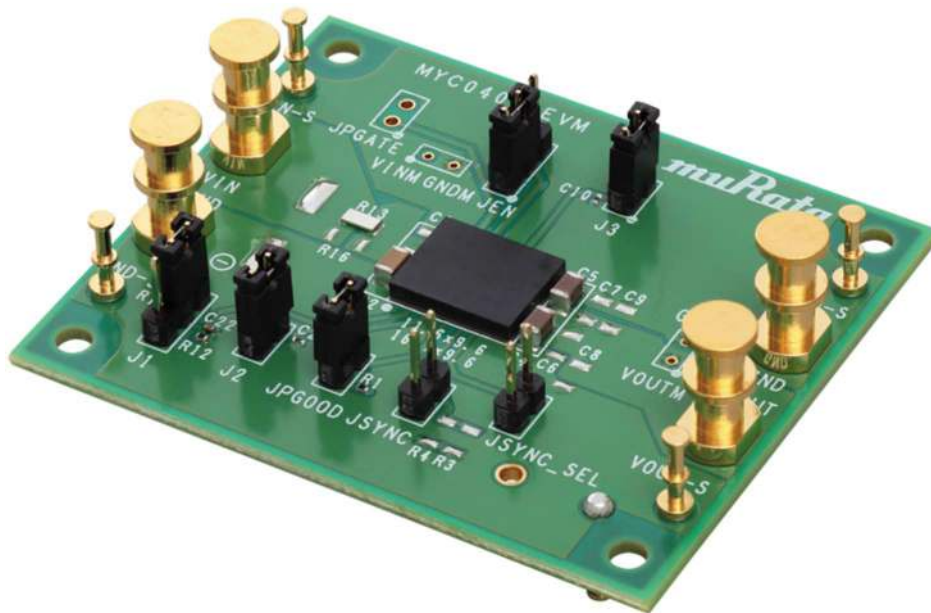

Figure 1. Evaluation Board

Performance summary

PARAMETER	SYMBOL	CONDITIONS	MIN	TYP	MAX	UNITS
INPUT SUPPLY						
Input voltage range	VIN		20	48	60	V
OUTPUT						
Efficiency Full Load		VIN=48V, IOU=6A		95.0		%
Switching Frequency	FSW			270		kHz
Output Current (Continuous)	IOU Cont	Inside recommended OP range	0	-	6	A
VOU Voltage	VOU	ILOAD=No load, DC		VIN/4		V

Table 1. performance summary

Quick Start Guide

Figure 2. Highlights the user interface items associated with the EVM.

The *VIN Power* terminals are used for connection to the host input supply and the *VOUT Power* terminals are used for connection to the load. Sense(+/-) test points for both VIN and VOUT, located near the power terminals are intended to be used as voltage monitoring points where voltmeters can be connected to measure VIN and VOUT. **Do not connect these S+ and S- monitoring test points as the input supply or output load connection points.**

Control jumpers located to the top and bottom of the device are made available to test the features of the device. The VDD must be applied to the PGOOD for the PGOOD signal using the PGOOD jumper (JPGOOD).

The SYNCSEL jumper (JSYNC_SEL) is provided for selecting synchronization. The EN jumper (JEN) can be controlled ON/ OFF. Always remove input power before changing the jumper settings.

Evaluation overview

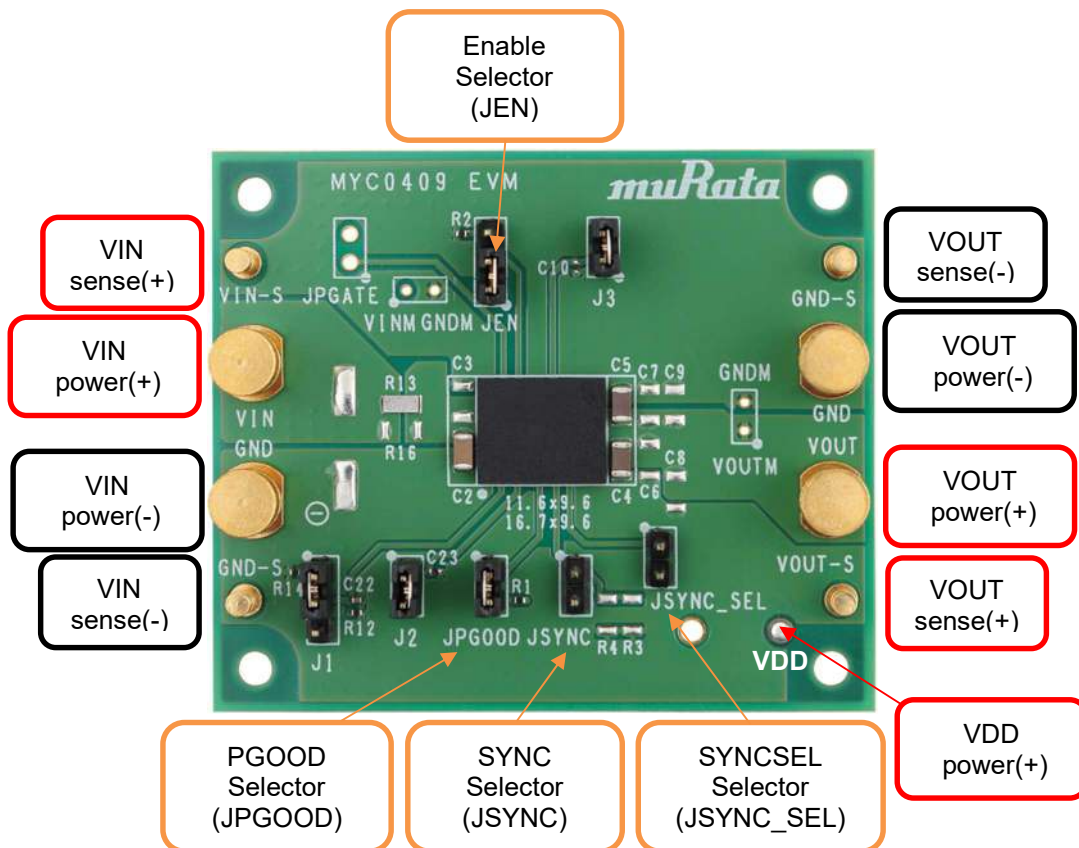

Figure 2. MYC0409 EVM User Interface (Top view)

Terminal functions and Jumper settings

FUNCTION/TERMINAL	JUMPER (RECOMMENDATION)	DESCRIPTION
VIN power (+/-)		Power input pin and Input Ground pin.
VOUT power (+/-)		Power output pin and output Ground pin.
VIN sense (+/-)		Sensing pin for measuring the input voltage.
VOUT sense (+/-)		Sensing pin for measuring the output voltage.
VDD power (+)		Power input pin. The VDD must be input 3.3 - 5V. It pulls PGOOD up to VDD.
EN (JEN)	Short (1 and 2)	Enable pin. Open: It can be used to control EN input. Short (1 and 2): It pulls EN up to VIN.
PGOOD (JPGOOD)	Short	Power GOOD pin. It pulls PGOOD up to VDD. Do not open this pin.
SYNCSEL (JSYNC_SEL)	Open	SYNCSEL pin. Open: SYNC= disabled. Short: SYNC= Clock output.
SYNC (JSYNC)	Open	CLOCK IN / OUT pin. Do not short this pin.
J1	Open	Unused jumper pin. Do not short this pin.
J2, J3	Short	Unused jumper pin. Do not open these pins.

Table 2. Terminal functions and Jumper settings

Power Input and Output Descriptions

The VIN power terminal is used to connect to the input supply, and the VOUT power terminal is used to connect to the load. The VDD power terminal is used to connect to pull PGOOD up.

Caution: Do not use these sense(+) and sense(-) terminals as the input supply or output load connection points. The PCB traces connecting to these sense terminals are not designed to support high currents. High currents may cause damage the PCB traces.

Test Point Descriptions

The sense(+) and Sense(-) test points for both VIN and VOUT, located near the power terminal are intended to be used as voltage monitoring points where voltmeters can be connected to measure VIN and VOUT.

Jumper Descriptions

The SYNCSEL SELECT jumper (**JSYNC_SEL**) is provided for selecting the SYNC terminal control.

Before applying power to the EVM, ensure that the jumper is present and properly positioned for the SYNC terminal control. Refer to Table 2 for the recommended jumper settings. The EN jumper (**JEN**) is provided for pulling up Vin. The PGOOD jumper (**JPGOOD**) is provided for pulling up VDD. Always remove input power before changing the jumper settings.

J1, J2 and J3 are unused jumper pins. Do not change the initial setting.

EVM connection

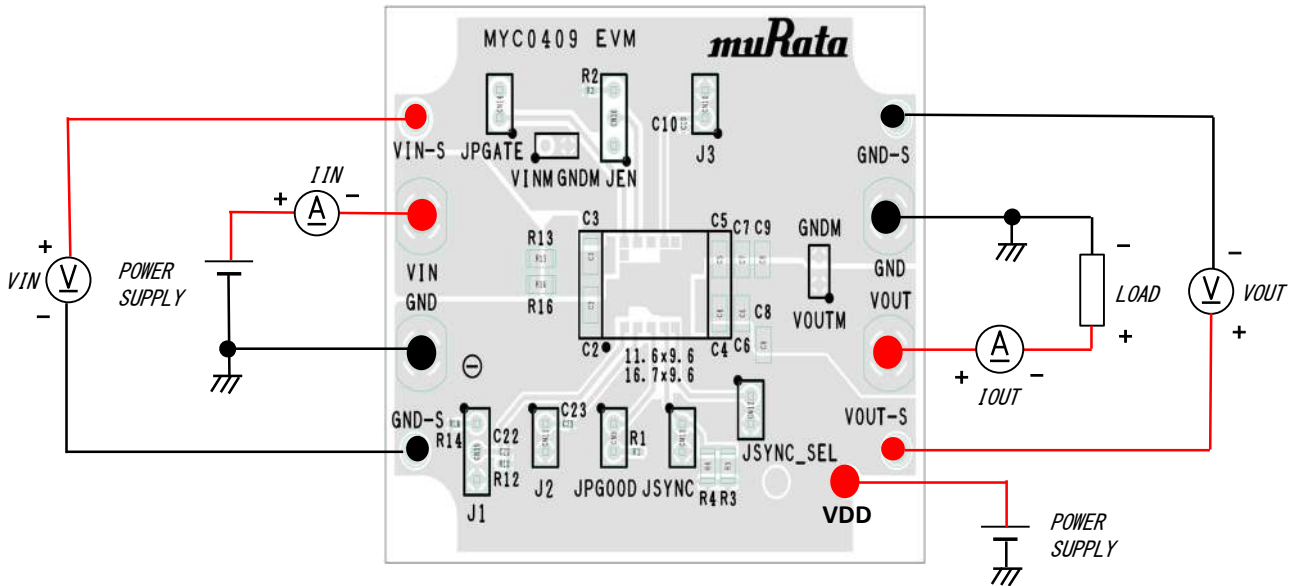

Figure 3. EVM Connection

Start-Up Procedure

1. Set the power supply current limit to at least 2A. Connect the power supply to VIN power(+) and VIN power(-).
2. Set the power supply current limit to at least 1mA. Connect the power supply to VDD and VOUT power(-).
3. Connect one electronic load with more than 6A capacity between Vout power(+) and Vout power(-). Do not turn on the load before PGOOD become high.
4. Set the PGOOD jumper (**JPGOOD**) pull up VDD. The EN jumper (**JEN**) pull up Vin, it is written dot on the board. The SYNCSEL SELECT jumper (**JSYNC_SEL**) you desire.
5. Set VDD voltage to 5V and turn it on.
6. Set input voltage to 48V and turn it on.
7. Measure the output voltages. VOUT should be $V_{in}/4=12V$.
8. Slowly increase the load current while monitoring the output voltages. The outputs should drop because this module is just divider.

Performance Data

Figure 4. through Figure 10. demonstrate the MYC0409-EVM performance. The following test results show the typical performance of the evaluation board.

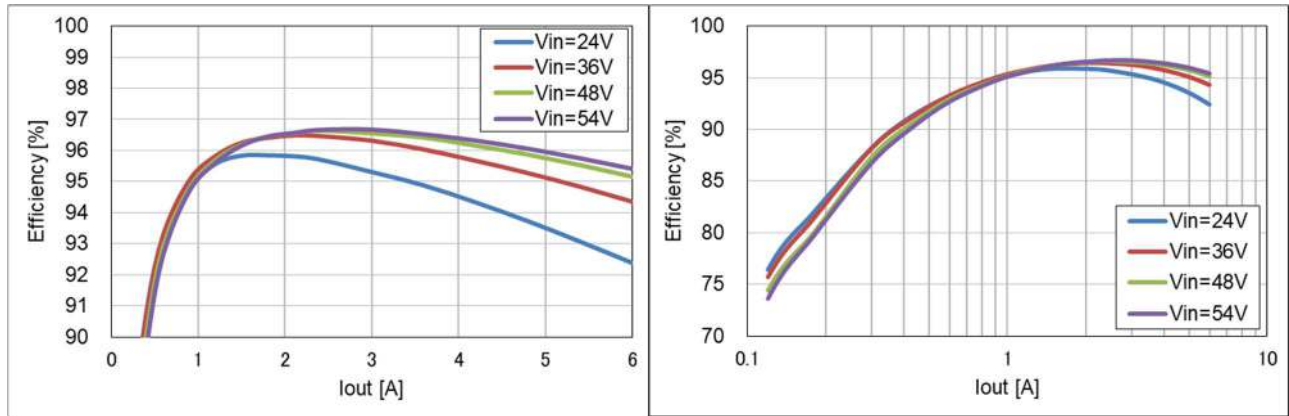

Figure 4. Efficiency (Linear, Log scale)

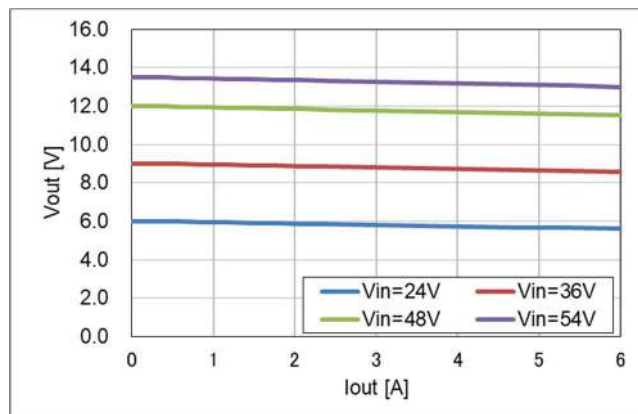

Figure 5. Output voltage

Startup waveforms with VIN=48V, No load, Ta=25degC.

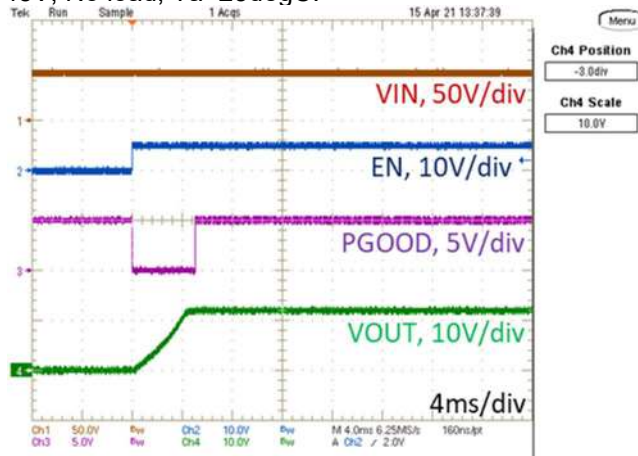

Figure 6. Start-up Waveform

Shutdown waveforms with VIN=12V, IOU=6A, Ta=25degC.

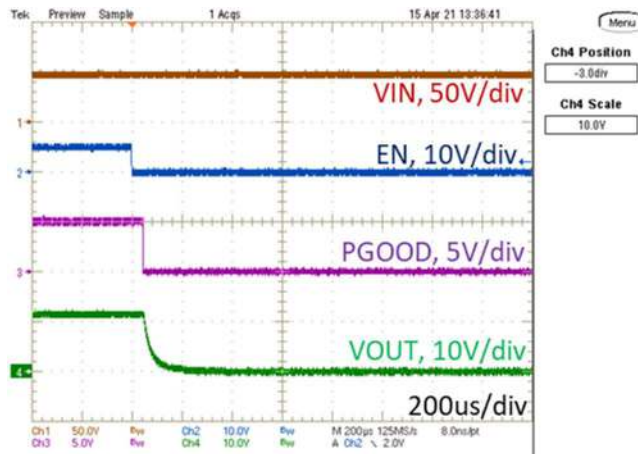

Figure 7. Shutdown Waveform

VOUT ripple waveforms with VIN=12V, IOU=6A, Ta=25degC.

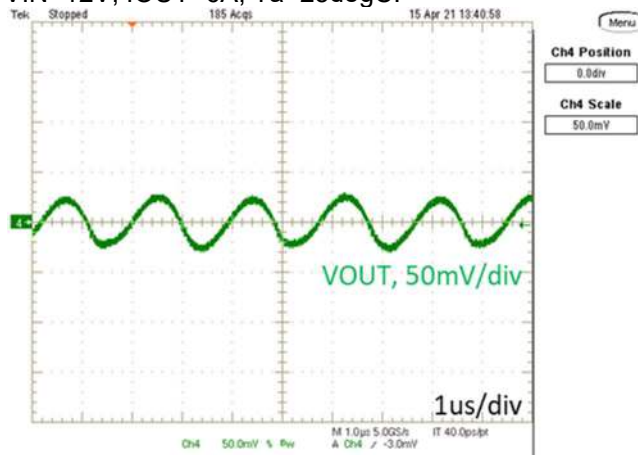

Figure 8. VOUT ripple Waveform

Load transient response waveforms with VIN=12V, IOU=0A to 6A, Ta=25degC.

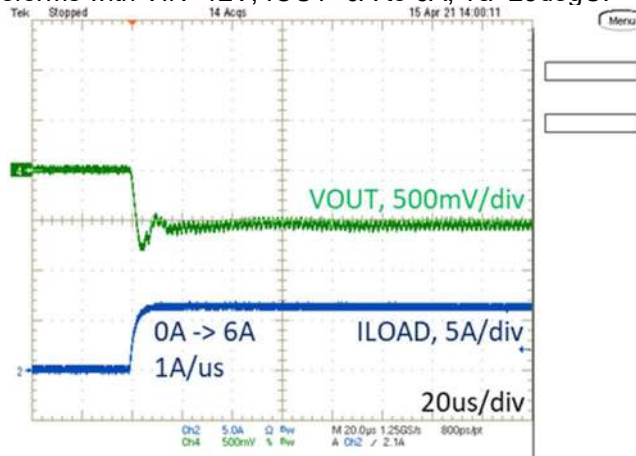

Figure 9. Load transient response Waveform (0A to 6A)

Load transient response waveforms with VIN=12V, IOU=6A to 0A, Ta=25degC.

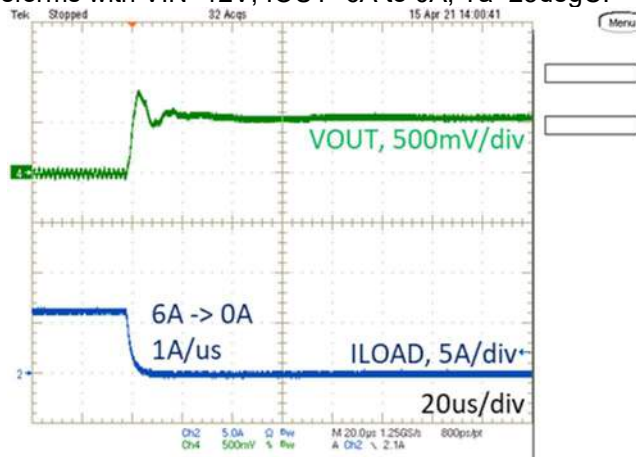

Figure 10. Load transient response Waveform (6A to 0A)

MYC0409 EVM Bill of Materials (BOM)

REFERENCE	QTY	VALUE	DESCRIPTION	SIZE	PART NUMBER	MANUFACTURER
C1	1	100uF	Input Capacitor 100μF,			
C2	1	4.7uF	Input Capacitor 4.7μF, 100V,+/-10%, X7S	1206	GRM31CC72A4 75KE11	Murata
C4, C5	2	22uF	Output Capacitor 22μF, 25V,+/-20%, X7S	1206	GRM31CC71E2 26ME15	Murata
R1, R2	2	10KOhm	Pull up resistor for Power Good Indication Pull down resistor for Enable function 5%, 0.1W	0402	RK73B1ETTP10 3J	KOA
R13			Jumper	1206	TLRZ2BTTD	KOA
	4		Jumper			
	4		Sense terminals for Vin and Vout		WT-3-2	
	4		Power terminals for Vin and Vout		GT-2-1	
M1	1		Power module		MYC0409-NA	Murata

Table 3. MYC0409 EVM Bill of materials

MYC0409 EVM Schematic

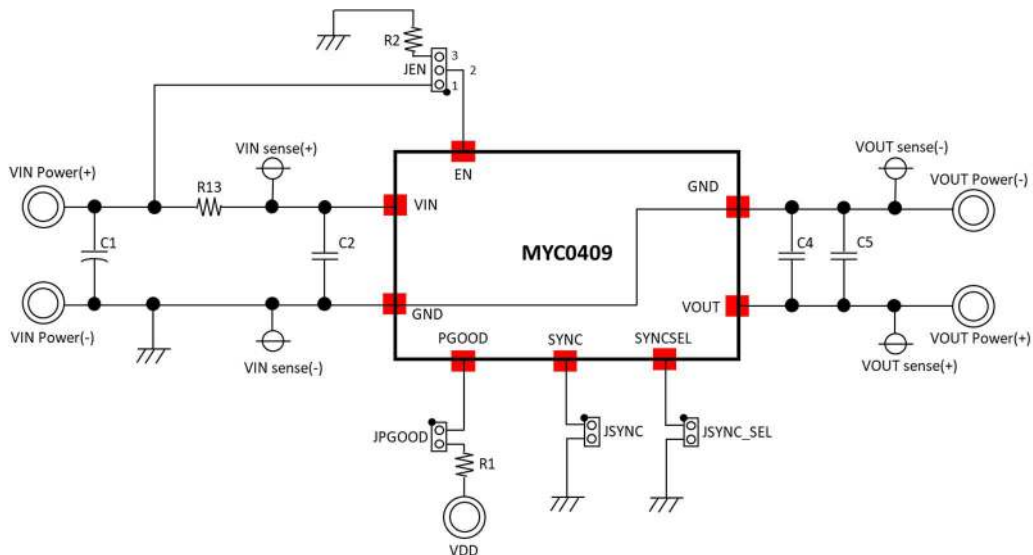

Figure 11. MYC0409 EVM schematic

EVM PCB Layout

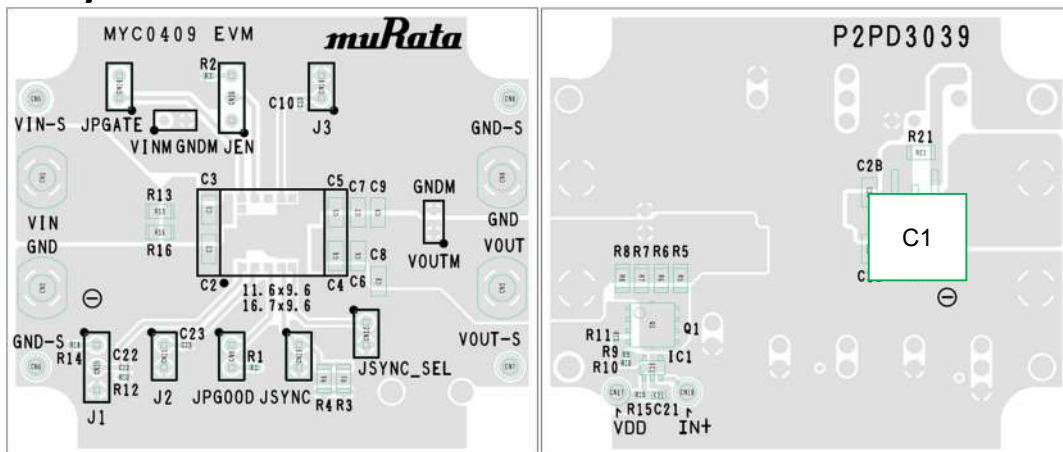

Figure 12. Evaluation Board Layout (Top and Bottom)

Notices

CAUTION

1. EVMs are not finished products. Murata delivers EVM for use in a research and development evaluation purpose only.
2. Please make sure that your product has been evaluated and confirmed to your specifications when our product is used in your product.
3. All the items and parameters in this approval sheet for product specification are based on the premise that our product is used for the purpose, under the condition and in the environment agreed upon between you and us. You are requested not to use our product in a manner deviating from such agreement.
4. If you have any concerns about materials other than those listed in the RoHS directive, please contact us.
5. Be sure to provide an appropriate fail-safe functionality in your product to prevent secondary damage that could be caused by the abnormal function or failure of our product.
6. Do not allow our product to be exposed to excess moisture under any circumstances.

Sales Contact

For additional information, contact Sales at muratalpdc@murata.com.

Disclaimers

The information in this document is believed to be reliable. However, Murata assumes no liability for the use of this information. Use shall be entirely at the user's own risk. No patent rights or licenses to any circuits described in this document are implied or granted to any third party. Murata's products are not designed or intended for use in devices or systems intended for surgical implant, or in other applications intended to support or sustain life, or in any application in which the failure of the Murata product could create a situation in which personal injury or death might occur. Murata assumes no liability for damages, including consequential or incidental damages, arising out of the use of its products in such applications.

Copyright and Trademark

©2021 Murata Manufacturing Co., Ltd. All rights reserved.



This product is subject to the following [operating requirements](#) and the [Life and Safety Critical Application Sales Policy](#):
Refer to: <https://power.murata.com/en/requirements>

Murata Manufacturing Co., Ltd makes no representation that the use of its products in the circuits described herein, or the use of other technical information contained herein, will not infringe upon existing or future patent rights. The descriptions contained herein do not imply the granting of licenses to make, use, or sell equipment constructed in accordance therewith. Spec and cautions are subject to change without notice. © 2019 Murata Manufacturing Co., Ltd