



# Quad high-side switch (quad 15 mOhm)

The 15XS3400 is one in a family of devices designed for low-voltage automotive lighting applications. Its four low  $R_{DS(on)}$  MOSFETs (quad 15 mOhm) can control four separate 55 W/28 W bulbs, and/or Xenon modules, and/or LEDs.

Programming, control and diagnostics are accomplished using a 16-bit SPI interface. Its output with selectable slew rate improves electromagnetic compatibility (EMC) behavior. Additionally, each output has its own parallel input or SPI control for pulse-width modulation (PWM) control. The 15XS3400 allows the user to program via the SPI the fault current trip levels and duration of acceptable lamp inrush. The device has Fail-safe mode to provide functionality of the outputs in case of MCU damage.

**15XS3400**

**HIGH-SIDE SWITCH**

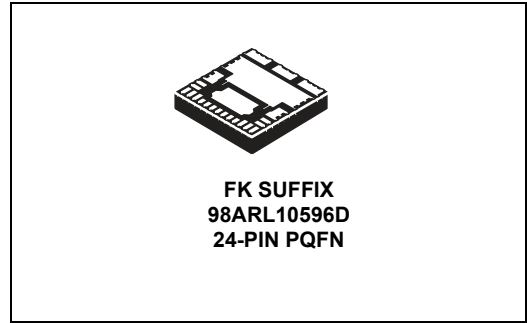

**Features**

- Four protected 15 mΩ high-side switches (at 25 °C)
- Operating voltage range of 6.0 V to 20 V with standby current < 5.0 μA, extended mode from 4.0 V to 28 V
- 8.0 MHz 16-bit 3.3 V and 5.0 V SPI control and status reporting with daisy chain capability
- PWM module using external clock or calibratable internal oscillator with programmable outputs delay management
- Smart overcurrent shutdown, severe short-circuit, overtemperature protection with time limited autoretry, and Fail-safe mode in case of MCU damage
- Output OFF or ON openload detection compliant to bulbs or LEDs and short to battery detection
- Analog current feedback with selectable ratio and board temperature feedback

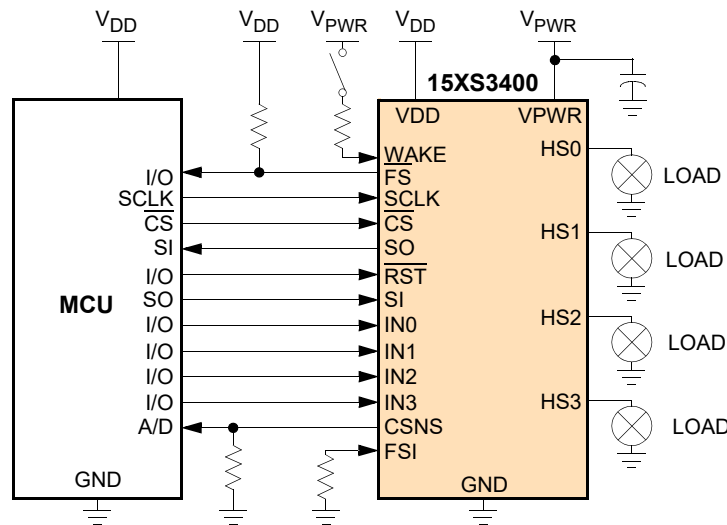

Figure 1. 15XS3400 simplified application diagram



# Table of Contents

1	Orderable parts	3
2	Device variations	3
3	Internal block diagram	4
4	Pin connections	5
5	Electrical characteristics	7
5.1	Maximum ratings	7
5.2	Static electrical characteristics	9
5.3	Dynamic electrical characteristics	14
5.4	Timing diagrams	21
6	Functional description	24
6.1	Introduction	24
6.2	Functional pin description	24
6.3	Functional internal block description	26
7	Functional device operation	27
7.1	SPI protocol description	27
7.2	Operational modes	27
7.3	Protection and diagnostic features	32
7.4	Logic commands and registers	37
8	Typical applications	45
9	Packaging	46
9.1	Soldering information	46
9.2	Package dimensions	47
10	Additional documentation	51
10.1	Thermal addendum (Rev 2.0)	51
11	Revision history	56

# 1 Orderable parts

This section describes the part numbers available to be purchased along with their differences. Valid orderable part numbers are provided on the web. To determine the orderable part numbers for this device, go to <http://www.nxp.com> and perform a part number search for the following device numbers.

**Table 1. Orderable part variations**

Part number <sup>(1)</sup>	Temperature (T <sub>A</sub> )	Package
MC15XS3400CHFK	-40 °C to 125 °C	24-pin PQFN
MC15XS3400DHFk		

Notes

- To order parts in tape and reel, add the R2 suffix to the part number.

# 2 Device variations

**Table 2. Device variations**

Characteristic	Symbol	Min	Typ	Max	Unit
Wake input clamp voltage, I <sub>CL(WAKE)</sub> < 2.5 mA <ul style="list-style-type: none"> <li>15XS3400C</li> <li>15XS3400D</li> </ul>	V <sub>CL(WAKE)</sub>	18 20	25 27	32 35	V
Fault detection blanking time <ul style="list-style-type: none"> <li>15XS3400C</li> <li>15XS3400D</li> </ul>	t <sub>FAULT</sub>	- -	5.0 5.0	20 10	μs
Output shutdown delay time <ul style="list-style-type: none"> <li>15XS3400C</li> <li>15XS3400D</li> </ul>	t <sub>DETECT</sub>	- -	7.0 7.0	30 20	μs
Peak Package Reflow Temperature During Reflow <sup>(2), (3)</sup>	T <sub>PPRT</sub>	Note 3			°C

Notes

- Pin soldering temperature limit is for 40 seconds maximum duration. Not designed for immersion soldering. Exceeding these limits may cause malfunction or permanent damage to the device.
- NXP's Package Reflow capability meets Pb-free requirements for JEDEC standard J-STD-020C. For Peak Package Reflow Temperature and Moisture Sensitivity Levels (MSL), go to [www.nxp.com](http://www.nxp.com), search by part number (remove prefixes/suffixes) and enter the core ID to view all orderable parts, and review parametrics.

### 3 Internal block diagram

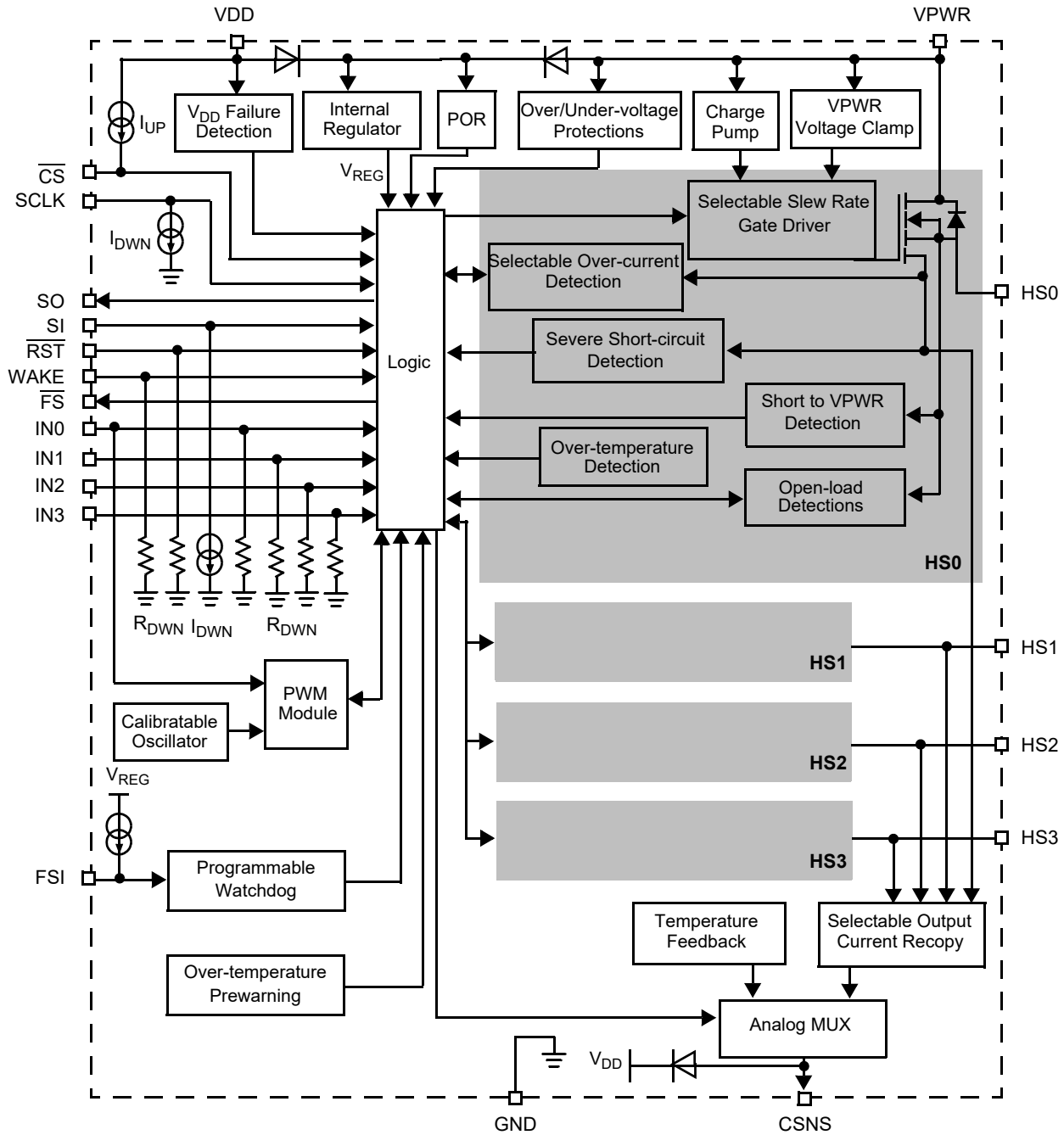

Figure 2. 15XS3400 simplified internal block diagram

## 4 Pin connections

### Transparent Top View of Package

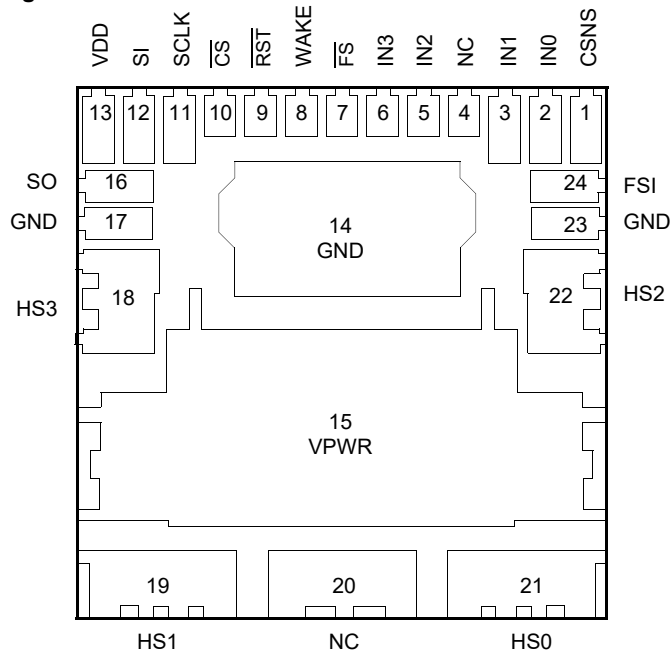

Figure 3. 15XS3400 pin connections

Table 3. 15XS3400 pin definitions

A functional description of each pin can be found in the Functional Pin Description section beginning on page 24.

Pin number	Pin name	Pin function	Formal name	Definition
1	CSNS	Output	Output current monitoring	This pin reports an analog value proportional to the designated HS[0:3] output current or the temperature of the GND flag (pin 14). It is used externally to generate a ground-referenced voltage for the microcontroller (MCU). Current recopy and temperature feedback is SPI programmable.
2 3 5 6	IN0 IN1 IN2 IN3	Input	Direct inputs	Each direct input controls the device mode. The IN[0:3] high-side input pins are used to directly control HS0:HS3 high-side output pins. The PWM frequency can be generated from IN0 pin to PWM module in case the external clock is set.
7	FS	Output	Fault status (active low)	This pin is an open drain configured output requiring an external pull-up resistor to V <sub>DD</sub> for fault reporting.
8	WAKE	Input	Wake	This input pin controls the device mode.
9	RST	Input	Reset	This input pin is used to initialize the device configuration and fault registers, as well as place the device in a low-current Sleep mode.
10	CS	Input	Chip select (active low)	This input pin is connected to a chip select output of a master microcontroller (MCU).
11	SCLK	Input	Serial clock	This input pin is connected to the MCU providing the required bit shift clock for SPI communication.
12	SI	Input	Serial input	This pin is a command data input pin connected to the SPI serial data output of the MCU or to the SO pin of the previous device of a daisy-chain of devices.
13	VDD	Power	Digital drain voltage	This pin is an external voltage input pin used to supply power interfaces to the SPI bus.
14, 17, 23	GND	Ground	Ground	These pins, internally shorted, are the ground for the logic and analog circuitry of the device. These ground pins must be also shorted in the board.

**Table 3. 15XS3400 pin definitions (continued)**

A functional description of each pin can be found in the Functional Pin Description section beginning on page [24](#).

Pin number	Pin name	Pin function	Formal name	Definition
15	VPWR	Power	Positive power supply	This pin connects to the positive power supply and is the source of operational power for the device.
16	SO	Output	Serial output	This output pin is connected to the SPI serial data input pin of the MCU or to the SI pin of the next device of a daisy-chain of devices.
18 19 21 22	HS3 HS1 HS0 HS2	Output	High-side outputs	Protected 15 mΩ high-side power output pins to the load.
4, 20	NC	N/A	No connect	These pins may not be connected.
24	FSI	Input	Fail-safe input	This input enables the watchdog timeout feature.

# 5 Electrical characteristics

## 5.1 Maximum ratings

**Table 4. Maximum ratings**

All voltages are with respect to ground unless otherwise noted. Exceeding these ratings may cause a malfunction or permanent damage to the device.

Ratings	Symbol	Value	Unit
<b>ELECTRICAL RATINGS</b>			
V <sub>PWR</sub> supply voltage range <ul style="list-style-type: none"> <li>Load dump at 25 °C (400 ms)</li> <li>Maximum operating voltage</li> <li>Reverse battery at 25 °C (2.0 min)</li> </ul>	V <sub>PWR(SS)</sub>	41 28 -18	V
V <sub>DD</sub> supply voltage range	V <sub>DD</sub>	-0.3 to 5.5	V
Input/output voltage	(7)	-0.3 to V <sub>DD</sub> +0.3	V
WAKE input clamp current	I <sub>CL(WAKE)</sub>	2.5	mA
CSNS input clamp current	I <sub>CL(CSNS)</sub>	2.5	mA
HS [0:3] voltage <ul style="list-style-type: none"> <li>Positive</li> <li>Negative</li> </ul>	V <sub>HS[0:3]</sub>	41 -16	V
Output current <sup>(4)</sup>	I <sub>HS[0:3]</sub>	6	A
Output clamp energy using single-pulse method <sup>(5)</sup>	E <sub>CL[0:3]</sub>	100	mJ
ESD voltage <sup>(6)</sup> <ul style="list-style-type: none"> <li>Human Body Model (HBM) for HS[0:3], V<sub>PWR</sub> and GND</li> <li>Human Body Model (HBM) for other pins</li> <li>Charge Device Model (CDM)               <ul style="list-style-type: none"> <li>Corner pins (1, 13, 19, 21)</li> <li>All other pins (2-12, 14-18, 20, 22-24)</li> </ul> </li> </ul>	V <sub>ESD1</sub> V <sub>ESD2</sub>  V <sub>ESD3</sub> V <sub>ESD4</sub>	±8000 ±2000  ±750 ±500	V
<b>THERMAL RATINGS</b>			
Operating temperature <ul style="list-style-type: none"> <li>Ambient</li> <li>Junction</li> </ul>	T <sub>A</sub> T <sub>J</sub>	-40 to 125 -40 to 150	°C
Storage temperature	T <sub>STG</sub>	-55 to 150	°C

**Notes**

- Continuous high-side output current rating so long as maximum junction temperature is not exceeded. Calculation of maximum output current using package thermal resistance is required.
- Active clamp energy using single-pulse method (L = 2.0 mH, R<sub>L</sub> = 0 Ω, V<sub>PWR</sub> = 14 V, T<sub>J</sub> = 150°C initial).
- ESD testing is performed in accordance with the Human Body Model (HBM) (C<sub>ZAP</sub> = 100 pF, R<sub>ZAP</sub> = 1500 Ω), the Machine Model (MM) (C<sub>ZAP</sub> = 200 pF, R<sub>ZAP</sub> = 0 Ω), and the Charge Device Model (CDM), Robotic (C<sub>ZAP</sub> = 4.0 pF).
- Input / Output pins are: IN[0:3],  $\overline{RST}$ , FSI, CSNS, SI, SCLK,  $\overline{CS}$ , SO,  $\overline{FS}$

**Table 4. Maximum ratings (continued)**

All voltages are with respect to ground unless otherwise noted. Exceeding these ratings may cause a malfunction or permanent damage to the device.

Ratings	Symbol	Value	Unit
<b>THERMAL RESISTANCE</b>			
Thermal resistance <sup>(8)</sup> <ul style="list-style-type: none"> <li>• Junction to Case</li> <li>• Junction to Ambient</li> </ul>	$R_{\theta JC}$ $R_{\theta JA}$	<1.0 30	°C/W
Peak Package Reflow Temperature During Reflow <sup>(9), (10)</sup>	$T_{PPRT}$	Note 10	°C

**Notes**

8. Device mounted on a 2s2p test board per JEDEC JESD51-2. 15 °C/W of  $R_{\theta JA}$  can be reached in a real application case (4 layers board).
9. Pin soldering temperature limit is for 40 seconds maximum duration. Not designed for immersion soldering. Exceeding these limits may cause malfunction or permanent damage to the device.
10. NXP's Package Reflow capability meets Pb-free requirements for JEDEC standard J-STD-020C. For Peak Package Reflow Temperature and Moisture Sensitivity Levels (MSL), go to [www.nxp.com](http://www.nxp.com), search by part number (remove prefixes/suffixes) and enter the core ID to view all orderable parts, and review parametrics.



## 5.2 Static electrical characteristics

**Table 5. Static electrical characteristics**

Characteristics noted under conditions  $6.0\text{ V} \leq V_{PWR} \leq 20\text{ V}$ ,  $3.0\text{ V} \leq V_{DD} \leq 5.5\text{ V}$ ,  $-40\text{ }^\circ\text{C} \leq T_A \leq 125\text{ }^\circ\text{C}$ ,  $\text{GND} = 0\text{ V}$ , unless otherwise noted. Typical values noted reflect the approximate parameter means at  $T_A = 25\text{ }^\circ\text{C}$  under nominal conditions, unless otherwise noted.

Characteristic	Symbol	Min	Typ	Max	Unit
<b>POWER INPUTS</b>					
Battery supply voltage range <ul style="list-style-type: none"> <li>Fully operational</li> <li>Extended mode<sup>(11)</sup></li> </ul>	$V_{PWR}$	6.0 4.0	– –	20 28	V
Battery clamp voltage <sup>(12)</sup>	$V_{PWR(\text{CLAMP})}$	41	47	53	V
$V_{PWR}$ operating supply current <ul style="list-style-type: none"> <li>Outputs commanded ON, HS[0:3] open, IN[0:3] &gt; <math>V_{IH}</math></li> </ul>	$I_{PWR(\text{ON})}$	–	6.5	20	mA
$V_{PWR}$ supply current <ul style="list-style-type: none"> <li>Outputs commanded OFF, OFF Open-load Detection Disabled, HS[0:3] shorted to the ground with <math>V_{DD} = 5.5\text{ V}</math></li> <li>WAKE &gt; <math>V_{IH}</math> or <math>\overline{\text{RST}} &gt; V_{IH}</math> and IN[0:3] &lt; <math>V_{IL}</math></li> </ul>	$I_{PWR(\text{SBY})}$	–	6.0	8.0	mA
Sleep state supply current <ul style="list-style-type: none"> <li><math>V_{PWR} = 12\text{ V}</math>, <math>\overline{\text{RST}} = \text{WAKE} = \text{IN}[0:3] &lt; V_{IL}</math>, HS[0:3] shorted to the ground</li> <li><math>T_A = 25\text{ }^\circ\text{C}</math></li> <li><math>T_A = 85\text{ }^\circ\text{C}</math></li> </ul>	$I_{PWR(\text{SLEEP})}$	– –	1.0 –	5.0 30	$\mu\text{A}$
$V_{DD}$ supply voltage	$V_{DD(\text{ON})}$	3.0	–	5.5	V
$V_{DD}$ supply current at $V_{DD} = 5.5\text{ V}$ <ul style="list-style-type: none"> <li>No SPI communication</li> <li>8.0 MHz SPI communication<sup>(13)</sup></li> </ul>	$I_{DD(\text{ON})}$	– –	1.6 5.0	2.2 –	mA
$V_{DD}$ sleep state current at $V_{DD} = 5.5\text{ V}$	$I_{DD(\text{SLEEP})}$	–	–	5.0	$\mu\text{A}$
Overshoot shutdown threshold	$V_{PWR(\text{OV})}$	28	32	36	V
Overshoot shutdown hysteresis	$V_{PWR(\text{OVHYS})}$	0.2	0.8	1.5	V
Undervoltage shutdown threshold <sup>(14)</sup>	$V_{PWR(\text{UV})}$	3.3	3.9	4.3	V
Recovery undervoltage shutdown threshold	$V_{PWR(\text{UV})\_UP}$	3.4	4.1	4.5	V
$V_{PWR}$ and $V_{DD}$ power-on reset threshold	$V_{\text{SUPPLY}(\text{POR})}$	0.5	–	0.9	$V_{PWR}$ (UV)
$V_{DD}$ supply failure threshold (for $V_{PWR} > V_{PWR(\text{UV})}$ )	$V_{DD(\text{FAIL})}$	2.2	2.5	2.8	

**Notes**

- In Extended mode, the functionality is guaranteed but not the electrical parameters. From 4.0 V to 6.0 V voltage range, the device is only protected with the thermal shutdown detection.
- Measured with the outputs open.
- Typical value guaranteed per design.
- Output will automatically recover with time limited autoretry to instructed state when  $V_{PWR}$  voltage is restored to normal as long as the  $V_{PWR}$  degradation level did not go below the undervoltage power-on reset threshold. This applies to all internal device logic that is supplied by  $V_{PWR}$  and assumes that the external  $V_{DD}$  supply is within specification.

**Table 5. Static electrical characteristics (continued)**

Characteristics noted under conditions  $6.0\text{ V} \leq V_{PWR} \leq 20\text{ V}$ ,  $3.0\text{ V} \leq V_{DD} \leq 5.5\text{ V}$ ,  $-40\text{ }^\circ\text{C} \leq T_A \leq 125\text{ }^\circ\text{C}$ ,  $\text{GND} = 0\text{ V}$ , unless otherwise noted. Typical values noted reflect the approximate parameter means at  $T_A = 25\text{ }^\circ\text{C}$  under nominal conditions, unless otherwise noted.

Characteristic	Symbol	Min	Typ	Max	Unit
<b>OUTPUTS HS0 TO HS3</b>					
Output Drain-to-Source ON resistance ( $I_{HS} = 5.0\text{ A}$ , $T_A = 25\text{ }^\circ\text{C}$ ) <ul style="list-style-type: none"> <li>• <math>V_{PWR} = 4.5\text{ V}</math></li> <li>• <math>V_{PWR} = 6.0\text{ V}</math></li> <li>• <math>V_{PWR} = 10\text{ V}</math></li> <li>• <math>V_{PWR} = 13\text{ V}</math></li> </ul>	$R_{DS(ON)_{25}}$	– – – –	– – – –	55 24 15 15	mΩ
Output Drain-to-Source ON resistance ( $I_{HS} = 5.0\text{ A}$ , $T_A = 150\text{ }^\circ\text{C}$ ) <ul style="list-style-type: none"> <li>• <math>V_{PWR} = 4.5\text{ V}</math></li> <li>• <math>V_{PWR} = 6.0\text{ V}</math></li> <li>• <math>V_{PWR} = 10\text{ V}</math></li> <li>• <math>V_{PWR} = 13\text{ V}</math></li> </ul>	$R_{DS(ON)_{150}}$	– – – –	– – – –	95 41 26 26	mΩ
Output Source-to-Drain ON resistance ( $I_{HS} = -5.0\text{ A}$ , $V_{PWR} = -18\text{ V}$ ) <sup>(15)</sup> <ul style="list-style-type: none"> <li>• <math>T_A = 25\text{ }^\circ\text{C}</math></li> <li>• <math>T_A = 150\text{ }^\circ\text{C}</math></li> </ul>	$R_{SD(ON)}$	– –	– –	22.5 30	mΩ
Maximum severe short-circuit impedance detection <sup>(16)</sup>	$R_{SHORT}$	28	64	100	mΩ
Output overcurrent detection levels ( $6.0\text{ V} \leq V_{HS[0:3]} \leq 20\text{ V}$ )					A
28 W bit = 0	OCHI1_0	78	94.0	110	
	OCHI2_0	50	60.0	70	
	OC1_0	44.1	52.5	60.9	
	OC2_0	37.8	45.0	52.2	
	OC3_0	31.5	37.5	43.5	
	OC4_0	25.2	30.0	34.8	
	OCLO4_0	18.9	22.5	26.1	
	OCLO3_0	12.6	15.0	17.4	
	OCLO2_0	10.0	12.0	14.0	
	OCLO1_0	6.4	8.0	9.6	
28 W bit = 1	OCHI1_1	39	47.0	55	
	OCHI2_1	25	30.0	35	
	OC1_1	22.0	26.2	30.5	
	OC2_1	18.9	22.5	26.1	
	OC3_1	15.7	18.7	21.8	
	OC4_1	12.6	15.0	17.4	
	OCLO4_1	4.5	6.0	7.5	
	OCLO3_1	4.5	6.0	7.5	
	OCLO2_1	4.5	6.0	7.5	
	OCLO1_1	3.0	4.0	5.0	

**Notes**

15. Source-Drain ON resistance (reverse Drain-to-Source ON resistance) with negative polarity  $V_{PWR}$ .
16. Short-circuit impedance calculated from HS[0:3] to GND pins. Value guaranteed per design.

**Table 5. Static electrical characteristics (continued)**

Characteristics noted under conditions  $6.0\text{ V} \leq V_{\text{PWR}} \leq 20\text{ V}$ ,  $3.0\text{ V} \leq V_{\text{DD}} \leq 5.5\text{ V}$ ,  $-40\text{ }^\circ\text{C} \leq T_{\text{A}} \leq 125\text{ }^\circ\text{C}$ ,  $\text{GND} = 0\text{ V}$ , unless otherwise noted. Typical values noted reflect the approximate parameter means at  $T_{\text{A}} = 25\text{ }^\circ\text{C}$  under nominal conditions, unless otherwise noted.

Characteristic	Symbol	Min	Typ	Max	Unit
Current sense ratio ( $6.0\text{ V} \leq V_{\text{HS}[0:3]} \leq 20\text{ V}$ , $\text{CSNS} \leq 5.0\text{ V}$ ) <sup>(17)</sup> <ul style="list-style-type: none"> <li>• 28 W bit = 0               <ul style="list-style-type: none"> <li>CSNS_ratio bit = 0</li> <li>CSNS_ratio bit = 1</li> </ul> </li> <li>• 28 W bit = 1               <ul style="list-style-type: none"> <li>CSNS_ratio bit = 0</li> <li>CSNS_ratio bit = 1</li> </ul> </li> </ul>	 CSR0_0 CSR1_0  CSR0_1 CSR1_1	 – –  – –	 1/8700 1/49000  1/4350 1/26500	 – –  – –	 –    –
Current sense ratio (CSR0) accuracy ( $6.0\text{ V} \leq V_{\text{HS}[0:3]} \leq 20\text{ V}$ ) with 28 W bit=0 <ul style="list-style-type: none"> <li>• Output current               <ul style="list-style-type: none"> <li>12.5 A</li> <li>5.0 A</li> <li>3.0 A</li> <li>1.5 A</li> </ul> </li> </ul>	CSR0_0_ACC	-12 -13 -16 -20	– – – –	12 13 16 20	%
Current sense ratio (CSR0) accuracy ( $6.0\text{ V} \leq V_{\text{HS}} \leq 20\text{ V}$ ) with 28 W bit=1 <ul style="list-style-type: none"> <li>• Output current               <ul style="list-style-type: none"> <li>3.0 A</li> <li>1.5 A</li> </ul> </li> </ul>	CSR0_1_ACC	-16 -20	– –	16 20	%
CSR0 current recopy accuracy with one calibration point ( $6.0\text{ V} \leq V_{\text{HS}[0:3]} \leq 20\text{ V}$ ) <sup>(18)</sup> <ul style="list-style-type: none"> <li>• Output current               <ul style="list-style-type: none"> <li>5.0 A</li> </ul> </li> </ul>	CSR0_0_ACC(CAL)	-5.0	–	5.0	%

**Notes**

17. Current sense ratio =  $I_{\text{CSNS}} / I_{\text{HS}[0:3]}$ .
18. Based on statistical analysis, it is not production tested.

**Table 5. Static electrical characteristics (continued)**

Characteristics noted under conditions  $6.0\text{ V} \leq V_{PWR} \leq 20\text{ V}$ ,  $3.0\text{ V} \leq V_{DD} \leq 5.5\text{ V}$ ,  $-40\text{ }^\circ\text{C} \leq T_A \leq 125\text{ }^\circ\text{C}$ ,  $GND = 0\text{ V}$ , unless otherwise noted. Typical values noted reflect the approximate parameter means at  $T_A = 25\text{ }^\circ\text{C}$  under nominal conditions, unless otherwise noted.

Characteristic	Symbol	Min	Typ	Max	Unit
<b>OUTPUTS HS0 TO HS3 (continued)</b>					
$C_{SR0}$ current recopy temperature drift ( $6.0\text{ V} \leq V_{HS[0:3]} \leq 20\text{ V}$ ) with 28 W bit=0 <sup>(19)</sup> <ul style="list-style-type: none"> <li>Output current</li> <li>5.0 A</li> </ul>	$\Delta(C_{SR0\_0})/\Delta(T)$			0.04	%/ $^\circ\text{C}$
Current sense ratio ( $C_{SR1}$ ) accuracy ( $6.0\text{ V} \leq V_{HS[0:3]} \leq 20\text{ V}$ ) with 28 W bit=0 <ul style="list-style-type: none"> <li>Output current</li> <li>12.5 A</li> <li>75 A</li> </ul>	$C_{SR1\_0\_ACC}$	-17 -12	- -	+17 +12	%
Current sense clamp voltage <ul style="list-style-type: none"> <li>CSNS open; <math>I_{HS[0:3]} = 5.0\text{ A}</math> with <math>C_{SR0}</math> ratio</li> </ul>	$V_{CL}(CSNS)$	$V_{DD}+0.25$	-	$V_{DD}+1.0$	V
OFF openload detection source current <sup>(20)</sup>	$I_{OLD}(OFF)$	30	-	100	$\mu\text{A}$
OFF openload fault detection voltage threshold	$V_{OLD}(THRES)$	2.0	3.0	4.0	V
ON openload fault detection current threshold	$I_{OLD}(ON)$	100	300	600	mA
ON openload fault detection current threshold with LED $V_{HS[0:3]} = V_{PWR} - 0.75\text{ V}$	$I_{OLD}(ON\_LED)$	2.5	5.0	10	mA
Output short to $V_{PWR}$ detection voltage threshold Output programmed OFF	$V_{OSD}(THRES)$	$V_{PWR}-1.2$	$V_{PWR}-0.8$	$V_{PWR}-0.4$	V
Output negative clamp voltage <ul style="list-style-type: none"> <li><math>0.5\text{ A} \leq I_{HS[0:3]} \leq 5.0\text{ A}</math>, output programmed OFF</li> </ul>	$V_{CL}$	-22	-	-16	V
Output overtemperature shutdown (for $4.5\text{ V} < V_{PWR} < 28\text{ V}$ )	$T_{SD}$	155	175	195	$^\circ\text{C}$

**Notes**

- Based on statistical data:  $\Delta(C_{SR0})/\Delta(T) = \{(\text{measured } I_{CSNS} \text{ at } T_1 - \text{measured } I_{CSNS} \text{ at } T_2) / \text{measured } I_{CSNS} \text{ at room}\} / \{T_1 - T_2\}$ . No production tested.
- Output OFF openload detection current is the current required to flow through the load for the purpose of detecting the existence of an openload condition when the specific output is commanded OFF. Pull-up current is measured for  $V_{HS} = V_{OLD}(THRES)$

**Table 5. Static electrical characteristics (continued)**

Characteristics noted under conditions  $6.0\text{ V} \leq V_{PWR} \leq 20\text{ V}$ ,  $3.0\text{ V} \leq V_{DD} \leq 5.5\text{ V}$ ,  $-40\text{ }^\circ\text{C} \leq T_A \leq 125\text{ }^\circ\text{C}$ ,  $\text{GND} = 0\text{ V}$ , unless otherwise noted. Typical values noted reflect the approximate parameter means at  $T_A = 25\text{ }^\circ\text{C}$  under nominal conditions, unless otherwise noted.

Characteristic	Symbol	Min	Typ	Max	Unit
<b>CONTROL INTERFACE</b>					
Input logic high voltage <sup>(21)</sup>	$V_{IH}$	2.0	–	$V_{DD}+0.3$	V
Input logic low voltage <sup>(21)</sup>	$V_{IL}$	-0.3	–	0.8	V
Input logic pull-down current (SCLK, SI) <sup>(24)</sup>	$I_{DWN}$	5.0	–	20	$\mu\text{A}$
Input logic pull-up current ( $\overline{\text{CS}}$ ) <sup>(25)</sup>	$I_{UP}$	5.0	–	20	$\mu\text{A}$
SO, $\overline{\text{FS}}$ tri-state capacitance <sup>(22)</sup>	$C_{SO}$	–	–	20	pF
Input logic pull-down resistor ( $\overline{\text{RST}}$ , WAKE and IN[0:3])	$R_{DWN}$	125	250	500	k $\Omega$
Input capacitance <sup>(22)</sup>	$C_{IN}$	–	4.0	12	pF
Wake input clamp voltage <sup>(23)</sup> , $I_{CL(\text{WAKE})} < 2.5\text{ mA}$ • 15XS3400C • 15XS3400D	$V_{CL(\text{WAKE})}$	18 20	25 27	32 35	V
Wake input forward voltage • $I_{CL(\text{WAKE})} = -2.5\text{ mA}$	$V_{F(\text{WAKE})}$	-2.0	–	-0.3	V
SO high state output voltage • $I_{OH} = 1.0\text{ mA}$	$V_{SOH}$	$V_{DD}-0.4$	–	–	V
SO and $\overline{\text{FS}}$ low-state output voltage • $I_{OL} = -1.0\text{ mA}$	$V_{SOL}$	–	–	0.4	V
SO, CSNS and $\overline{\text{FS}}$ tri-state leakage current • $\overline{\text{CS}} = V_{IH}$ and $0\text{ V} \leq V_{SO} \leq V_{DD}$ , or $\overline{\text{FS}} = 5.5\text{ V}$ , or CSNS=0.0 V	$I_{SO(\text{LEAK})}$	-2.0	0	2.0	$\mu\text{A}$
FSI external pull-down resistance <sup>(26)</sup> • Watchdog disabled • Watchdog enabled	RFS	– 10	0 Infinite	1.0 –	k $\Omega$

**Notes**

- Upper and lower logic threshold voltage range applies to SI,  $\overline{\text{CS}}$ , SCLK,  $\overline{\text{RST}}$ , IN[0:3] and WAKE input signals. The WAKE and  $\overline{\text{RST}}$  signals may be supplied by a derived voltage referenced to  $V_{PWR}$ .
- Input capacitance of SI,  $\overline{\text{CS}}$ , SCLK,  $\overline{\text{RST}}$ , IN[0:3] and WAKE. This parameter is guaranteed by process monitoring but is not production tested.
- The current must be limited by a series resistance when using voltages  $> 7.0\text{ V}$ .
- Pull-down current is with  $V_{SI} \geq 1.0\text{ V}$  and  $V_{SCLK} \geq 1.0\text{ V}$ .
- Pull-up current is with  $V_{\overline{\text{CS}}} \leq 2.0\text{ V}$ .  $\overline{\text{CS}}$  has an active internal pull-up to  $V_{DD}$ .
- In Fail-safe HS[0:3] depends respectively on ON[0:3]. FSI has an active internal pull-up to  $V_{REG} \sim 3.0\text{ V}$ .

## 5.3 Dynamic electrical characteristics

**Table 6. Dynamic electrical characteristics**

Characteristics noted under conditions  $6.0\text{ V} \leq V_{PWR} \leq 20\text{ V}$ ,  $3.0\text{ V} \leq V_{DD} \leq 5.5\text{ V}$ ,  $-40\text{ }^\circ\text{C} \leq T_A \leq 125\text{ }^\circ\text{C}$ ,  $\text{GND} = 0\text{ V}$ , unless otherwise noted. Typical values noted reflect the approximate parameter means at  $T_A = 25\text{ }^\circ\text{C}$  under nominal conditions, unless otherwise noted.

Characteristic	Symbol	Min	Typ	Max	Unit
<b>POWER OUTPUT TIMING HS0 TO HS3</b>					
Output rising medium slew rate (medium speed slew rate / SR[1:0]=00) <sup>(27)</sup> • $V_{PWR} = 14\text{ V}$	SR <sub>R_00</sub>	0.15	0.3	0.6	V/ $\mu\text{s}$
Output rising slow slew rate (low speed slew rate / SR[1:0]=01) <sup>(27)</sup> • $V_{PWR} = 14\text{ V}$	SR <sub>R_01</sub>	0.07	0.15	0.3	V/ $\mu\text{s}$
Output falling fast slew rate (high speed slew rate / SR[1:0]=10) <sup>(27)</sup> • $V_{PWR} = 14\text{ V}$	SR <sub>R_10</sub>	0.3	0.6	1.2	V/ $\mu\text{s}$
Output falling medium slew rate (medium speed slew rate / SR[1:0]=00) <sup>(27)</sup> • $V_{PWR} = 14\text{ V}$	SR <sub>F_00</sub>	0.15	0.3	0.6	V/ $\mu\text{s}$
Output falling slow slew rate (low speed slew rate / SR[1:0]=01) <sup>(27)</sup> • $V_{PWR} = 14\text{ V}$	SR <sub>F_01</sub>	0.07	0.15	0.3	V/ $\mu\text{s}$
Output rising fast slew rate (high speed slew rate / SR[1:0]=10) <sup>(27)</sup> • $V_{PWR} = 14\text{ V}$	SR <sub>F_10</sub>	0.3	0.6	1.2	V/ $\mu\text{s}$
Output turn-on delay time <sup>(28)</sup> • $V_{PWR} = 14\text{ V}$ for medium speed slew rate (SR[1:0]=00)	t <sub>DLY(ON)</sub>	40	60	90	$\mu\text{s}$
Output turn-off delay time <sup>(29)</sup> • $V_{PWR} = 14\text{ V}$ for medium speed slew rate (SR[1:0]=00)	t <sub>DLY(OFF)</sub>	40	60	90	$\mu\text{s}$
Driver output matching slew rate (SR <sub>R</sub> / SR <sub>F</sub> ) $V_{PWR} = 14\text{ V}$ @ $25\text{ }^\circ\text{C}$ and for medium speed slew rate (SR[1:0]=00)	$\Delta\text{SR}$	0.8	1.0	1.2	
Driver output matching time (t <sub>DLY(ON)</sub> - t <sub>DLY(OFF)</sub> ) $V_{PWR} = 14\text{ V}$ , $f_{\text{PWM}} = 240\text{ Hz}$ , PWM duty cycle = 50%, @ $25\text{ }^\circ\text{C}$ for medium speed slew rate (SR[1:0]=00)	$\Delta t_{\text{RF}}$	-25	0	25	$\mu\text{s}$

### Notes

27. Rise and fall slew rates measured across a  $5.0\ \Omega$  resistive load at high-side output = 30% to 70% (see [Figure 4](#), page 21).
28. Turn-on delay time measured from rising edge of any signal (IN[0:3] and  $\overline{\text{CS}}$ ) that would turn the output ON to  $V_{\text{HS}[0:3]} = V_{\text{PWR}} / 2$  with  $R_L = 5.0\ \Omega$  resistive load.
29. Turn-off delay time measured from falling edge of any signal (IN[0:3] and  $\overline{\text{CS}}$ ) that would turn the output OFF to  $V_{\text{HS}[0:3]} = V_{\text{PWR}} / 2$  with  $R_L = 5.0\ \Omega$  resistive load.

**Table 6. Dynamic electrical characteristics (continued)**

Characteristics noted under conditions  $6.0\text{ V} \leq V_{PWR} \leq 20\text{ V}$ ,  $3.0\text{ V} \leq V_{DD} \leq 5.5\text{ V}$ ,  $-40\text{ }^\circ\text{C} \leq T_A \leq 125\text{ }^\circ\text{C}$ ,  $\text{GND} = 0\text{ V}$ , unless otherwise noted. Typical values noted reflect the approximate parameter means at  $T_A = 25\text{ }^\circ\text{C}$  under nominal conditions, unless otherwise noted.

Characteristic	Symbol	Min	Typ	Max	Unit
<b>POWER OUTPUT TIMING HS0 TO HS3 (continued)</b>					
Fault detection blanking time <sup>(30)</sup> • 15XS3400C • 15XS3400D	$t_{\text{FAULT}}$	- -	5.0 5.0	20 10	$\mu\text{s}$
Output shutdown delay time <sup>(31)</sup> • 15XS3400C • 15XS3400D	$t_{\text{DETECT}}$	- -	7.0 7.0	30 20	$\mu\text{s}$
$\overline{\text{CS}}$ to CSNS valid time <sup>(32)</sup>	$t_{\text{CNSVAL}}$	-	70	100	$\mu\text{s}$
Watchdog timeout <sup>(33)</sup>	$t_{\text{WDTO}}$	217	310	400	ms
ON openload fault cyclic detection period with LED • Internal clock (PWM_en bit = 1 & CLOCK_Set = 1) • External clock (PWM_en bit = 1 & CLOCK_Set = 0)	$T_{\text{OLLED}}$	6.4 -	8.3 PWM period	12 -	ms

**Notes**

30. Time necessary to report the fault to  $\overline{\text{FS}}$  pin.
31. Time necessary to switch-off the output in case of OT or OC or SC or UV fault detection (from negative edge of  $\overline{\text{FS}}$  pin to HS voltage = 50% of  $V_{PWR}$
32. Time necessary for the CSNS to be with  $\pm 5\%$  of the targeted value (from HS voltage = 50% of  $V_{PWR}$  to  $\pm 5\%$  of the targeted CSNS value).
33. For FSI open, the watchdog timeout delay measured from the rising edge of RST, to HS[0,2] output state depend on the corresponding input command.

**Table 6. Dynamic electrical characteristics (continued)**

Characteristics noted under conditions  $6.0\text{ V} \leq V_{\text{PWR}} \leq 20\text{ V}$ ,  $3.0\text{ V} \leq V_{\text{DD}} \leq 5.5\text{ V}$ ,  $-40\text{ }^\circ\text{C} \leq T_{\text{A}} \leq 125\text{ }^\circ\text{C}$ ,  $\text{GND} = 0\text{ V}$ , unless otherwise noted. Typical values noted reflect the approximate parameter means at  $T_{\text{A}} = 25\text{ }^\circ\text{C}$  under nominal conditions, unless otherwise noted.

Characteristic	Symbol	Min	Typ	Max	Unit
Output overcurrent time step for 28 W bit = 0					ms
OC[1:0]=00 (slow by default)	$t_{\text{OC1\_00}}$	4.40	6.30	8.02	
	$t_{\text{OC2\_00}}$	1.62	2.32	3.00	
	$t_{\text{OC3\_00}}$	2.10	3.00	3.90	
	$t_{\text{OC4\_00}}$	2.88	4.12	5.36	
	$t_{\text{OC5\_00}}$	4.58	6.56	8.54	
	$t_{\text{OC6\_00}}$	10.16	14.52	18.88	
	$t_{\text{OC7\_00}}$	73.2	104.6	134.0	
OC[1:0]=01 (fast)	$t_{\text{OC1\_01}}$	1.10	1.57	2.00	
	$t_{\text{OC2\_01}}$	0.40	0.58	0.75	
	$t_{\text{OC3\_01}}$	0.52	0.75	0.98	
	$t_{\text{OC4\_01}}$	0.72	1.03	1.34	
	$t_{\text{OC5\_01}}$	1.14	1.64	2.13	
	$t_{\text{OC6\_01}}$	2.54	3.63	4.72	
	$t_{\text{OC7\_01}}$	18.2	26.1	34.0	
OC[1:0]=10 (medium)	$t_{\text{OC1\_10}}$	2.20	3.15	4.01	
	$t_{\text{OC2\_10}}$	0.81	1.16	1.50	
	$t_{\text{OC3\_10}}$	1.05	1.50	1.95	
	$t_{\text{OC4\_10}}$	1.44	2.06	2.68	
	$t_{\text{OC5\_10}}$	2.29	3.28	4.27	
	$t_{\text{OC6\_10}}$	5.08	7.26	9.44	
	$t_{\text{OC7\_10}}$	36.6	52.3	68.0	
OC[1:0]=11 (very slow)	$t_{\text{OC1\_11}}$	8.8	12.6	16.4	
	$t_{\text{OC2\_11}}$	3.2	4.6	21.4	
	$t_{\text{OC3\_11}}$	4.2	6.0	7.8	
	$t_{\text{OC4\_11}}$	5.7	8.2	10.7	
	$t_{\text{OC5\_11}}$	9.1	13.1	17.0	
	$t_{\text{OC6\_11}}$	20.3	29.0	37.7	
	$t_{\text{OC7\_11}}$	146.4	209.2	272.0	



**Table 6. Dynamic electrical characteristics (continued)**

Characteristics noted under conditions  $6.0\text{ V} \leq V_{\text{PWR}} \leq 20\text{ V}$ ,  $3.0\text{ V} \leq V_{\text{DD}} \leq 5.5\text{ V}$ ,  $-40\text{ }^\circ\text{C} \leq T_{\text{A}} \leq 125\text{ }^\circ\text{C}$ ,  $\text{GND} = 0\text{ V}$ , unless otherwise noted. Typical values noted reflect the approximate parameter means at  $T_{\text{A}} = 25\text{ }^\circ\text{C}$  under nominal conditions, unless otherwise noted.

Characteristic	Symbol	Min	Typ	Max	Unit
Output overcurrent time step for 28 W bit = 1					ms
OC[1:0]=00 (slow by default)	$t_{\text{OC1\_00}}$	3.4	4.9	6.4	
	$t_{\text{OC2\_00}}$	1.1	1.6	2.1	
	$t_{\text{OC3\_00}}$	1.4	2.1	2.8	
	$t_{\text{OC4\_00}}$	2.0	2.9	3.8	
	$t_{\text{OC5\_00}}$	3.4	4.9	6.4	
	$t_{\text{OC6\_00}}$	8.5	12.2	15.9	
	$t_{\text{OC7\_00}}$	62.4	89.2	116.0	
OC[1:0]=01 (fast)	$t_{\text{OC1\_01}}$	0.86	1.24	1.61	
	$t_{\text{OC2\_01}}$	0.28	0.40	0.52	
	$t_{\text{OC3\_01}}$	0.36	0.52	0.68	
	$t_{\text{OC4\_01}}$	0.51	0.74	0.96	
	$t_{\text{OC5\_01}}$	0.78	1.12	1.46	
	$t_{\text{OC6\_01}}$	2.14	3.06	3.98	
	$t_{\text{OC7\_01}}$	20.2	22.2	28.9	
OC[1:0]=10 (medium)	$t_{\text{OC1\_10}}$	1.7	2.5	3.3	
	$t_{\text{OC2\_10}}$	0.5	0.8	1.0	
	$t_{\text{OC3\_10}}$	0.7	1.0	1.3	
	$t_{\text{OC4\_10}}$	1.0	1.5	2.0	
	$t_{\text{OC5\_10}}$	1.7	2.5	3.3	
	$t_{\text{OC6\_10}}$	4.2	6.1	6.0	
	$t_{\text{OC7\_10}}$	31.2	44.6	58.0	
OC[1:0]=11 (very slow)	$t_{\text{OC1\_11}}$	6.8	9.8	12.8	
	$t_{\text{OC2\_11}}$	2.2	3.2	16.7	
	$t_{\text{OC3\_11}}$	2.9	4.2	5.5	
	$t_{\text{OC4\_11}}$	4.0	5.8	7.6	
	$t_{\text{OC5\_11}}$	6.8	9.8	12.8	
	$t_{\text{OC6\_11}}$	17.0	24.4	31.8	
	$t_{\text{OC7\_11}}$	124.8	178.4	232.0	

**Table 6. Dynamic electrical characteristics (continued)**

Characteristics noted under conditions  $6.0\text{ V} \leq V_{\text{PWR}} \leq 20\text{ V}$ ,  $3.0\text{ V} \leq V_{\text{DD}} \leq 5.5\text{ V}$ ,  $-40\text{ }^\circ\text{C} \leq T_{\text{A}} \leq 125\text{ }^\circ\text{C}$ ,  $\text{GND} = 0\text{ V}$ , unless otherwise noted. Typical values noted reflect the approximate parameter means at  $T_{\text{A}} = 25\text{ }^\circ\text{C}$  under nominal conditions, unless otherwise noted.

Characteristic	Symbol	Min	Typ	Max	Unit
Bulb cooling time step for 28 W bit = 0					ms
CB[1:0]=00 or 11 (medium)	$t_{\text{BC1\_00}}$	242	347	452	
	$t_{\text{BC2\_00}}$	126	181	236	
	$t_{\text{BC3\_00}}$	140	200	260	
	$t_{\text{BC4\_00}}$	158	226	294	
	$t_{\text{BC5\_00}}$	181	259	337	
	$t_{\text{BC6\_00}}$	211	302	393	
CB[1:0]=01 (fast)	$t_{\text{BC1\_01}}$	121	173	226	
	$t_{\text{BC2\_01}}$	63	90	118	
	$t_{\text{BC3\_01}}$	70	100	130	
	$t_{\text{BC4\_01}}$	79	113	147	
	$t_{\text{BC5\_01}}$	90	129	169	
	$t_{\text{BC6\_01}}$	105	151	197	
CB[1:0]=10 (slow)	$t_{\text{BC1\_10}}$	484	694	1904	
	$t_{\text{BC2\_10}}$	252	362	472	
	$t_{\text{BC3\_10}}$	280	400	520	
	$t_{\text{BC4\_10}}$	316	452	588	
	$t_{\text{BC5\_10}}$	362	518	674	
	$t_{\text{BC6\_10}}$	422	604	786	
for 28 W bit = 1					
CB[1:0]=00 or 11 (medium)	$t_{\text{BC1\_00}}$	291	417	542	
	$t_{\text{BC2\_00}}$	156	224	292	
	$t_{\text{BC3\_00}}$	178	255	332	
	$t_{\text{BC4\_00}}$	208	298	388	
	$t_{\text{BC5\_00}}$	251	359	467	
	$t_{\text{BC6\_00}}$	314	449	584	
CB[1:0]=01 (fast)	$t_{\text{BC1\_01}}$	146	209	272	
	$t_{\text{BC2\_01}}$	78	112	146	
	$t_{\text{BC3\_01}}$	88	127	166	
	$t_{\text{BC4\_01}}$	101	145	189	
	$t_{\text{BC5\_01}}$	126	180	234	
	$t_{\text{BC6\_01}}$	226	324	422	
CB[1:0]=10 (slow)	$t_{\text{BC1\_10}}$	583	834	1085	
	$t_{\text{BC2\_10}}$	312	448	582	
	$t_{\text{BC3\_10}}$	357	510	665	
	$t_{\text{BC4\_10}}$	417	596	775	
	$t_{\text{BC5\_10}}$	501	717	933	
	$t_{\text{BC6\_10}}$	628	898	1170	

**Table 6. Dynamic electrical characteristics (continued)**

Characteristics noted under conditions  $6.0\text{ V} \leq V_{\text{PWR}} \leq 20\text{ V}$ ,  $3.0\text{ V} \leq V_{\text{DD}} \leq 5.5\text{ V}$ ,  $-40\text{ }^\circ\text{C} \leq T_{\text{A}} \leq 125\text{ }^\circ\text{C}$ ,  $\text{GND} = 0\text{ V}$ , unless otherwise noted. Typical values noted reflect the approximate parameter means at  $T_{\text{A}} = 25\text{ }^\circ\text{C}$  under nominal conditions, unless otherwise noted.

Characteristic	Symbol	Min	Typ	Max	Unit
<b>PWM MODULE TIMING</b>					
Input PWM clock range on IN0	$f_{\text{IN0}}$	7.68	–	30.72	kHz
Input PWM clock low frequency detection range on IN0 <sup>(34)</sup>	$f_{\text{IN0(LOW)}}$	1.0	2.0	4.0	kHz
Input PWM clock high frequency detection range on IN0 <sup>(34)</sup>	$f_{\text{IN0(HIGH)}}$	100	200	400	kHz
Output PWM frequency range	$f_{\text{PWM}}$	-	-	1000	Hz
Output PWM frequency accuracy using calibrated oscillator	$A_{\text{FPWM(CAL)}}$	-10	–	+10	%
Default output PWM frequency using internal oscillator	$f_{\text{PWM(0)}}$	84	120	156	Hz
$\overline{\text{CS}}$ calibration low minimum time detection range	$t_{\text{CSB(MIN)}}$	14	20	26	$\mu\text{s}$
$\overline{\text{CS}}$ calibration Low Maximum Time Detection Range	$t_{\text{CSB(MAX)}}$	140	200	260	$\mu\text{s}$
Output PWM duty-cycle range for $f_{\text{PWM}} = 400\text{ Hz}$ <sup>(35)</sup>	$R_{\text{PWM\_400}}$	10		98	%
Output PWM duty-cycle range for $f_{\text{PWM}} = 200\text{ Hz}$ <sup>(35)</sup>	$R_{\text{PWM\_200}}$	5.0		98	%
Output PWM duty-cycle range for $f_{\text{PWM}} = 1.0\text{ kHz}$ <sup>(35)</sup>	$R_{\text{PWM\_1k}}$	6.0	-	94	%
<b>INPUT TIMING</b>					
Direct input toggle timeout	$t_{\text{IN}}$	175	250	325	ms
<b>AUTORETRY TIMING</b>					
Autoretry period	$t_{\text{AUTO}}$	105	150	195	ms
<b>TEMPERATURE ON THE GND FLAG</b>					
Thermal prewarning detection <sup>(36)</sup>	$T_{\text{OTWAR}}$	110	125	140	$^\circ\text{C}$
Analog temperature feedback at $T_{\text{A}} = 25\text{ }^\circ\text{C}$ with $R_{\text{CSNS}}=2.5\text{ k}\Omega$	$T_{\text{FEED}}$	1.15	1.20	1.25	V
Analog temperature feedback derating with $R_{\text{CSNS}}=2.5\text{ k}\Omega$ <sup>(37)</sup>	$\text{DT}_{\text{FEED}}$	-3.5	-3.7	-3.9	$\text{mV}/^\circ\text{C}$

**Notes**

34. Clock fail detector available for PWM\_en bit is set to logic [1] and CLOCK\_sel is set to logic [0].
35. The PWM ratio is measured at  $V_{\text{HS}} = 50\%$  of  $V_{\text{PWR}}$  and for the default SR value. It is possible to put the device fully-on (PWM duty-cycle 100%) and fully-off (duty-cycle 0%). For values outside this range, a calibration is needed between the PWM duty-cycle programming and the PWM on the output with  $R_{\text{L}} = 5.0\ \Omega$  resistive load.
36. Typical value guaranteed per design.
37. Value guaranteed per statistical analysis.

**Table 6. Dynamic electrical characteristics (continued)**

Characteristics noted under conditions  $6.0\text{ V} \leq V_{\text{PWR}} \leq 20\text{ V}$ ,  $3.0\text{ V} \leq V_{\text{DD}} \leq 5.5\text{ V}$ ,  $-40\text{ }^\circ\text{C} \leq T_{\text{A}} \leq 125\text{ }^\circ\text{C}$ ,  $\text{GND} = 0\text{ V}$ , unless otherwise noted. Typical values noted reflect the approximate parameter means at  $T_{\text{A}} = 25\text{ }^\circ\text{C}$  under nominal conditions, unless otherwise noted.

Characteristic	Symbol	Min	Typ	Max	Unit
<b>SPI INTERFACE CHARACTERISTICS<sup>(38)</sup></b>					
Maximum frequency of SPI operation	$f_{\text{SPI}}$	–	–	8.0	MHz
Required low state duration for $\overline{\text{RST}}$ <sup>(39)</sup>	$t_{\text{WRST}}$	10	–	–	$\mu\text{s}$
Rising edge of $\overline{\text{CS}}$ to falling edge of $\overline{\text{CS}}$ (required setup time) <sup>(40)</sup>	$t_{\overline{\text{CS}}}$	–	–	1.0	$\mu\text{s}$
Rising edge of $\overline{\text{RST}}$ to falling edge of $\overline{\text{CS}}$ (required setup time) <sup>(40)</sup>	$t_{\text{ENBL}}$	–	–	5.0	$\mu\text{s}$
Falling edge of $\overline{\text{CS}}$ to rising edge of SCLK (required setup time) <sup>(40)</sup>	$t_{\text{LEAD}}$	–	–	500	ns
Required high state duration of SCLK (required setup time) <sup>(40)</sup>	$t_{\text{WSCLKH}}$	–	–	50	ns
Required low state duration of SCLK (required setup time) <sup>(40)</sup>	$t_{\text{WSCLKI}}$	–	–	50	ns
Falling edge of SCLK to rising edge of $\overline{\text{CS}}$ (required setup time) <sup>(40)</sup>	$t_{\text{LAG}}$	–	–	60	ns
SI to falling edge of SCLK (required setup time) <sup>(41)</sup>	$t_{\text{SI(SU)}}$	–	–	37	ns
Falling edge of SCLK to SI (required setup time) <sup>(41)</sup>	$t_{\text{SI(HOLD)}}$	–	–	49	ns
SO rise time • $C_{\text{L}} = 80\text{ pF}$	$t_{\text{RSO}}$	–	–	13	ns
SO fall time • $C_{\text{L}} = 80\text{ pF}$	$t_{\text{FSO}}$	–	–	13	ns
SI, $\overline{\text{CS}}$ , SCLK, incoming signal rise time <sup>(41)</sup>	$t_{\text{RSI}}$	–	–	13	ns
SI, $\overline{\text{CS}}$ , SCLK, incoming signal fall time <sup>(41)</sup>	$t_{\text{FSI}}$	–	–	13	ns
Time from rising edge of SCLK to SO low-impedance <sup>(42)</sup>	$t_{\text{SO(EN)}}$	–	–	60	ns
Time from rising edge of SCLK to SO high-impedance <sup>(43)</sup>	$t_{\text{SO(DIS)}}$	–	–	60	ns

**Notes**

38. Parameters guaranteed by design.
39.  $\overline{\text{RST}}$  low duration measured with outputs enabled and going to OFF or disabled condition.
40. Maximum setup time required for the 15XS3400 is the minimum guaranteed time needed from the microcontroller.
41. Rise and Fall time of incoming SI,  $\overline{\text{CS}}$ , and SCLK signals suggested for design consideration to prevent the occurrence of double pulsing.
42. Time required for output status data to be available for use at SO. 1.0 k $\Omega$  on pull-up on  $\overline{\text{CS}}$ .
43. Time required for output status data to be terminated at SO. 1.0 k $\Omega$  on pull-up on  $\overline{\text{CS}}$ .

## 5.4 Timing diagrams

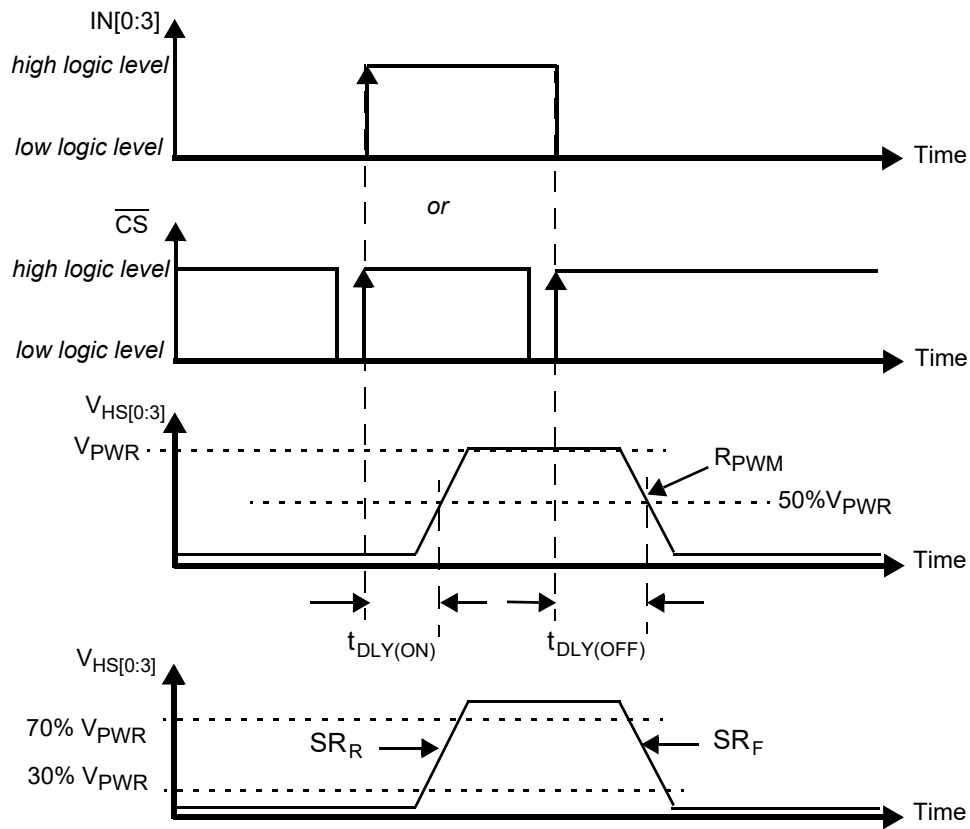

Figure 4. Output slew rate and time delays

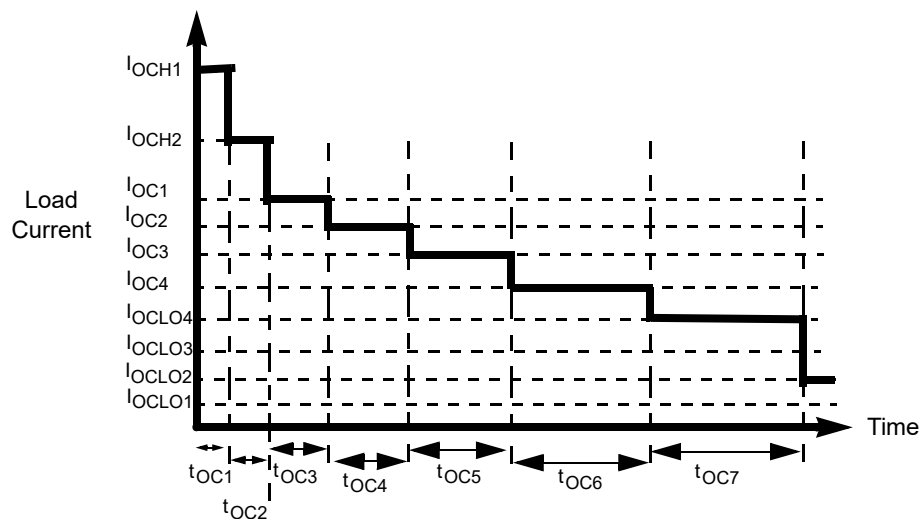

Figure 5. Overcurrent shutdown protection

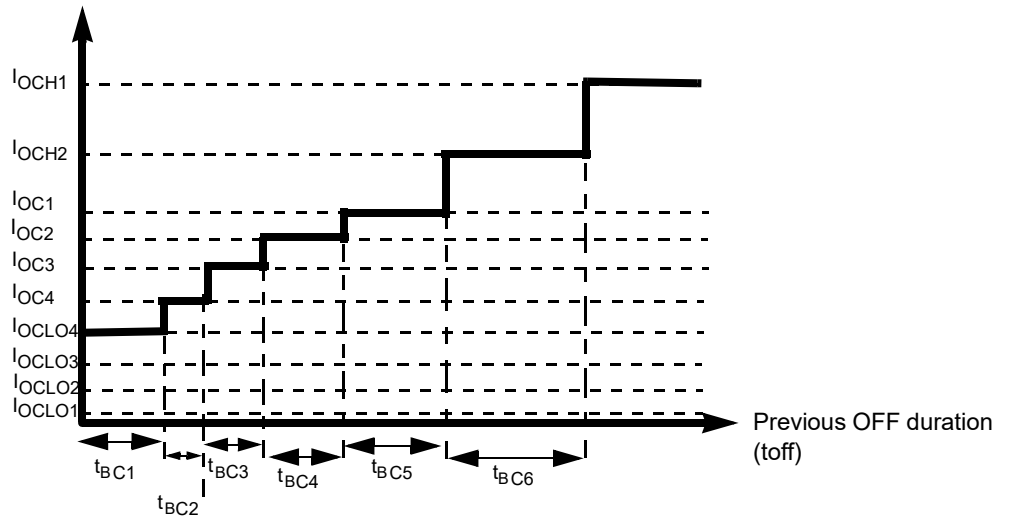

Figure 6. Bulb cooling management

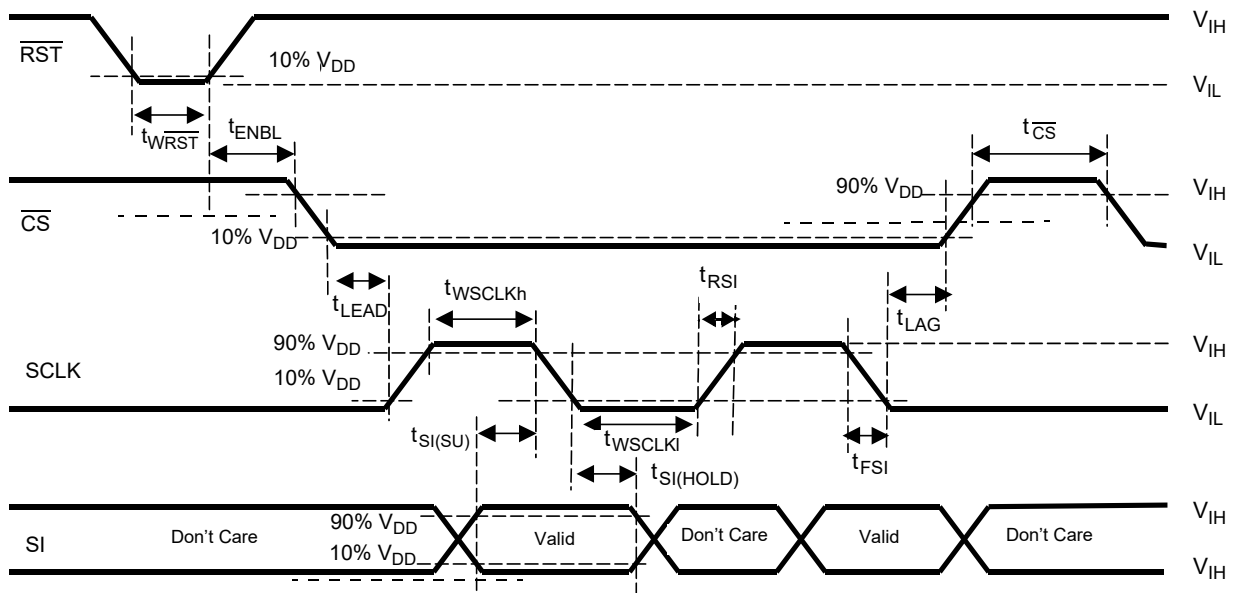
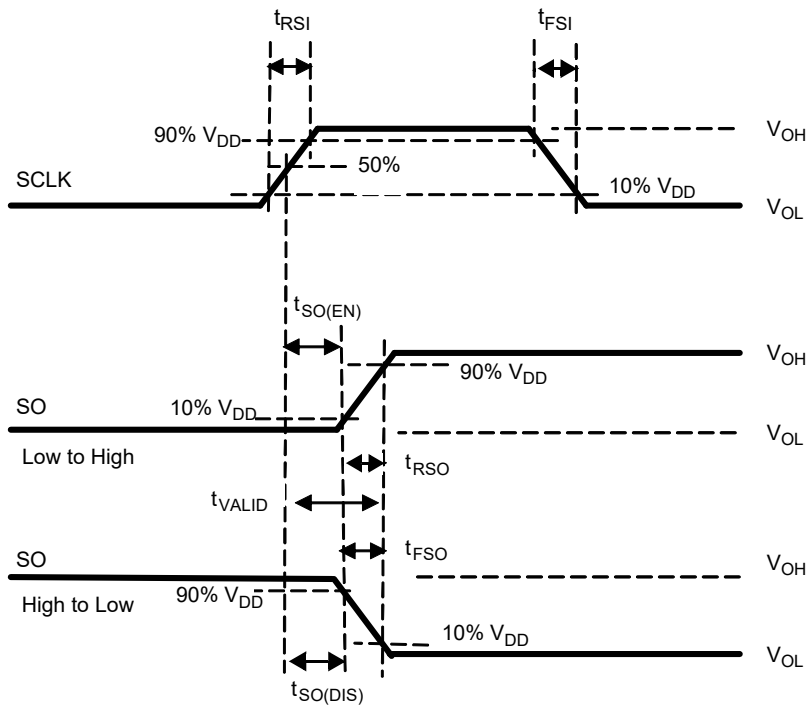

Figure 7. Input timing switching characteristics



**Figure 8. SCLK waveform and valid SO data delay time**

# 6 Functional description

## 6.1 Introduction

The 15XS3400 is one in a family of devices designed for low-voltage automotive lighting applications. Its four low  $R_{DS(on)}$  MOSFETs (quad 15 m $\Omega$ ) can control four separate 55 W/28 W bulbs and/or Xenon modules.

Programming, control and diagnostics are accomplished using a 16-bit SPI interface. Its output with selectable slew-rate improves electromagnetic compatibility (EMC) behavior. Additionally, each output has its own parallel input or SPI control for pulse-width modulation (PWM) control if desired. The 15XS3400 allows the user to program via the SPI the fault current trip levels and duration of acceptable lamp inrush. The device has Fail-safe mode to provide functionality of the outputs in case of MCU damage.

## 6.2 Functional pin description

### 6.2.1 Output current monitoring (CSNS)

The Current Sense pin provides a current proportional to the designated HS0:HS3 output or a voltage proportional to the temperature on the GND flag. That current is fed into a ground-referenced resistor (4.7 k $\Omega$  typical) and its voltage is monitored by an MCU's A/D. The output type is selected via the SPI. This pin can be tri-stated through the SPI.

### 6.2.2 Direct inputs (IN0, IN1, IN2, IN3)

Each IN input wakes the device. The IN0:IN3 high-side input pins are also used to directly control HS0:HS3 high-side output pins. If the outputs are controlled by the PWM module, the external PWM clock is applied to IN0 pin. These pins are to be driven with CMOS levels, and they have a passive internal pull-down,  $R_{DWN}$ .

### 6.2.3 Fault status ( $\overline{FS}$ )

This pin is an open drain configured output requiring an external pull-up resistor to  $V_{DD}$  for fault reporting. If a device fault condition is detected, this pin is active LOW. Specific device diagnostics and faults are reported via the SPI SO pin.

### 6.2.4 Wake

The wake input wakes the device. An internal clamp protects this pin from high damaging voltages with a series resistor (10 k $\Omega$  typ). This input has a passive internal pull-down,  $R_{DWN}$ .

### 6.2.5 Reset ( $\overline{RST}$ )

The reset input wakes the device. This is used to initialize the device configuration and fault registers, as well as place the device in a low-current Sleep mode. The pin also starts the watchdog timer when transitioning from logic [0] to logic [1]. This pin has a passive internal pull-down,  $R_{DWN}$ .

### 6.2.6 Chip select ( $\overline{CS}$ )

The  $\overline{CS}$  pin enables communication with the master microcontroller (MCU). When this pin is in a logic [0] state, the device is capable of transferring information to, and receiving information from, the MCU. The 15XS3400 latches in data from the input shift registers to the addressed registers on the rising edge of  $\overline{CS}$ . The device transfers status information from the power output to the Shift register on the falling edge of  $\overline{CS}$ . The SO output driver is enabled when  $\overline{CS}$  is logic [0].  $\overline{CS}$  should transition from a logic [1] to a logic [0] state only when SCLK is a logic [0].  $\overline{CS}$  has an active internal pull-up from  $V_{DD}$ ,  $I_{UP}$ .



## 6.2.7 Serial clock (SCLK)

The SCLK pin clocks the internal shift registers of the 15XS3400 device. The serial input (SI) pin accepts data into the input shift register on the falling edge of the SCLK signal while the serial output (SO) pin shifts data information out of the SO line driver on the rising edge of the SCLK signal. It is important the SCLK pin be in a logic low state whenever  $\overline{CS}$  makes any transition. For this reason, it is recommended the SCLK pin be in a logic [0] whenever the device is not accessed ( $\overline{CS}$  logic [1] state). SCLK has an active internal pull-down. When  $\overline{CS}$  is logic [1], signals at the SCLK and SI pins are ignored and SO is tri-stated (high-impedance) (see [Figure 10](#), page [27](#)). SCLK input has an active internal pull-down,  $I_{DWN}$ .

## 6.2.8 Serial input (SI)

This is a serial interface (SI) command data input pin. Each SI bit is read on the falling edge of SCLK. A 16-bit stream of serial data is required on the SI pin, starting with D15 (MSB) to D0 (LSB). The internal registers of the 15XS3400 are configured and controlled using a 5-bit addressing scheme described in [Table 11](#), page [37](#). Register addressing and configuration are described in [Table 12](#), page [37](#). SI input has an active internal pull-down,  $I_{DWN}$ .

## 6.2.9 Digital drain voltage (VDD)

This pin is an external voltage input pin used to supply power to the SPI circuit. In the event  $V_{DD}$  is lost ( $V_{DD}$  Failure), the device goes to Fail-safe mode.

## 6.2.10 Ground (GND)

These pins are the ground for the device.

## 6.2.11 Positive power supply (VPWR)

This pin connects to the positive power supply and is the source of operational power for the device. The VPWR contact is the backside surface mount tab of the package.

## 6.2.12 Serial output (SO)

The SO data pin is a tri-stateable output from the shift register. The SO pin remains in a high-impedance state until the  $\overline{CS}$  pin is put into a logic [0] state. The SO data is capable of reporting the status of the output, the device configuration, the state of the key inputs, etc. The SO pin changes state on the rising edge of SCLK and reads out on the falling edge of SCLK. SO reporting descriptions are provided in [Table 24](#), page [43](#).

## 6.2.13 High-side outputs (HS3, HS1, HS0, HS2)

Protected 15 m $\Omega$  high-side power outputs to the load.

## 6.2.14 Fail-safe input (FSI)

This pin incorporates an active internal pull-up current source from internal supply ( $V_{REG}$ ). This enables the watchdog timeout feature. When the FSI pin is opened, the watchdog circuit is enabled. After a watchdog timeout occurs, the output states depends on IN[0:3]. When the FSI pin is connected to GND, the watchdog circuit is disabled. The output states depends on IN[0:3] in case of  $V_{DD}$  failure condition, in case  $V_{DD}$  failure detection is activated ( $VDD\_FAIL\_en$  bit sets to logic [1]).

## 6.3 Functional internal block description

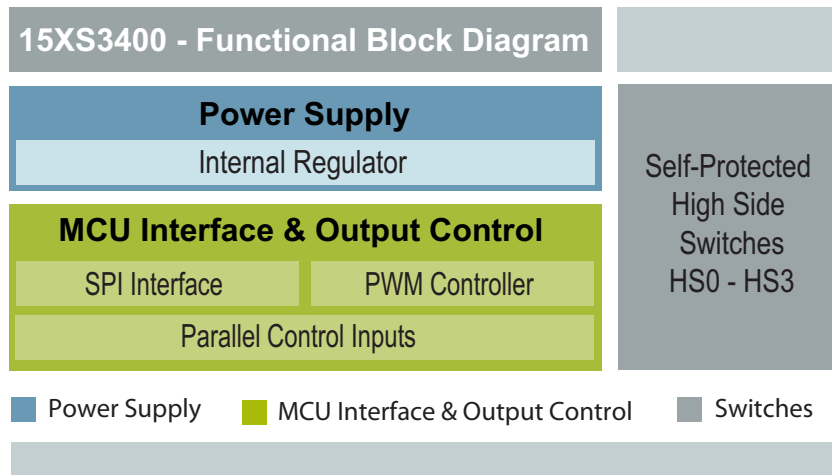

Figure 9. Functional block diagram

### 6.3.1 Power supply

The 15XS3400 is designed to operate from 4.0 V to 28 V on the VPWR pin. Characteristics are provided from 6.0V to 20 V for the device. The VPWR pin supplies power to internal regulator, analog, and logic circuit blocks. The VDD supply is used for Serial Peripheral Interface (SPI) communication in order to configure and diagnose the device. This IC architecture provides a low quiescent current Sleep mode. Applying  $V_{PWR}$  and  $V_{DD}$  to the device will place the device in the Normal mode. The device will transit to Fail-safe mode in case of failures on the SPI or/and on VDD voltage.

### 6.3.2 High-side switches: HS0 – HS3

These pins are the high-side outputs controlling automotive lamps located for the front of vehicle, such as 65 W/55 W bulbs and Xenon-HID modules. Those N-channel MOSFETs with  $15 \text{ m}\Omega R_{DS(on)}$  are self-protected and present extended diagnostics in order to detect bulb outage and short-circuit fault condition. The HS output is actively clamped during turn off of inductive loads and inductive battery line.

When driving DC motors or solenoid loads, demanding multiple switching, an external recirculation device must be used to maintain the device in its safe operating area.

### 6.3.3 MCU interface and output control

In Normal mode, each bulb is controlled directly from the MCU through SPI. A pulse width modulation control module allows improvement of lamp lifetime with bulb power regulation (PWM frequency range from 100 to 400 Hz) and addressing the dimming application (day running light). An analog feedback output provides a current proportional to the load current or the temperature of the board. The SPI is used to configure and to read the diagnostic status (faults) of high-side outputs. The reported fault conditions are: open load, short circuit to battery, short-circuit to ground (overcurrent and severe short-circuit), thermal shutdown, and under/overvoltage. Thanks to accurate and configurable overcurrent detection circuitry and wire-harness optimization, the vehicle is lighter.

In Fail-safe mode, each lamp is controlled with dedicated parallel input pins. The device is configured in default mode.

# 7 Functional device operation

## 7.1 SPI protocol description

The SPI interface has a full duplex, three-wire synchronous data transfer with four I/O lines associated with it: Serial Input (SI), Serial Output (SO), Serial Clock (SCLK), and Chip Select ( $\overline{\text{CS}}$ ).

The SI/SO pins of the 15XS3400 follow a first-in first-out (D15 to D0) protocol, with both input and output words transferring the most significant bit (MSB) first. All inputs are compatible with 5.0 V or 3.3 V CMOS logic levels.

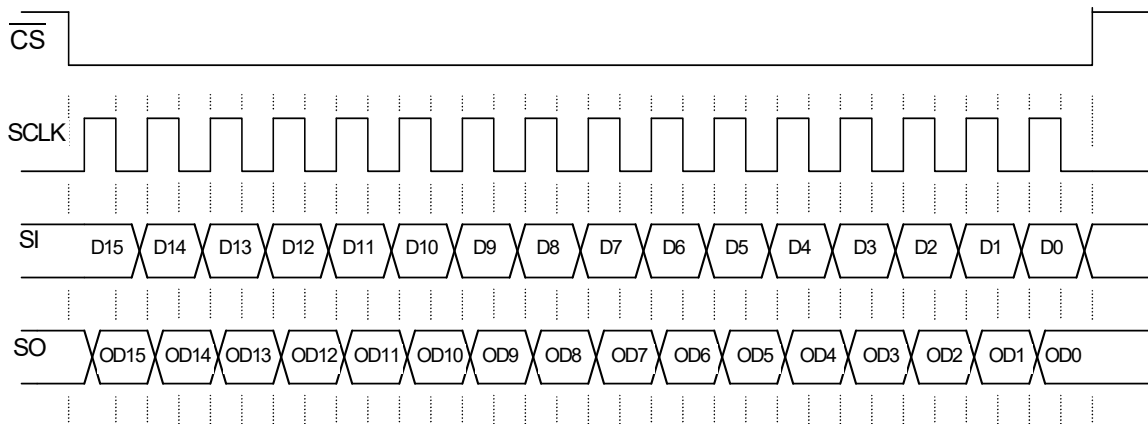

- Notes
1.  $\overline{\text{RST}}$  is a logic [1] state during the above operation.
  2. D15:D0 relate to the most recent ordered entry of data into the device.
  3. OD15:OD0 relate to the first 16 bits of ordered fault and status data out of the device.

Figure 10. Single 16-bit word SPI communication

## 7.2 Operational modes

The 15XS3400 has four operating modes: Sleep, Normal, Fail-safe and Fault. [Table 8](#) and [Figure 12](#) summarize details contained in succeeding paragraphs.

The [Figure 11](#) describes an internal signal called IN\_ON[x] depending on IN[x] input.

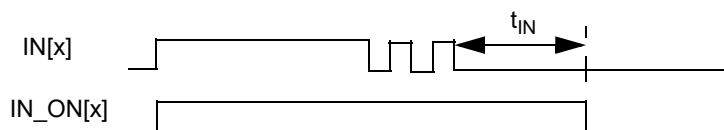

Figure 11. IN\_ON[x] internal signal

The 15XS3400 transits to operating modes according to the following signals:

- wake-up =  $\overline{\text{RST}}$  or WAKE or IN\_ON[0] or IN\_ON[1] or IN\_ON[2] or IN\_ON[3],
- fail = ( $V_{\text{DD}}$  Failure and VDD\_FAIL\_en) or (Watchdog time-out and FSI input not shorted to ground),
- fault = OC[0:3] or OT[0:3] or SC[0:3] or UV (UV) or (OV and OV\_dis).

**Table 7. 15XS3400 operating modes**

Mode	wake-up	fail	fault	Comments
Sleep	0	x	x	Device is in Sleep mode. All outputs are OFF.
Normal	1	0	0	Device is currently in Normal mode. Watchdog is active if enabled.
Fail-safe	1	1	0	Device is currently in Fail-safe mode due to watchdog timeout or $V_{DD}$ Failure conditions. The output states depend on the corresponding input in case FSI is open.
Fault	1	X	1	Device is currently in Fault mode. The faulted output(s) is (are) OFF. The safe autoretry circuitry is active to turn-on again the output(s).

x = Don't care.

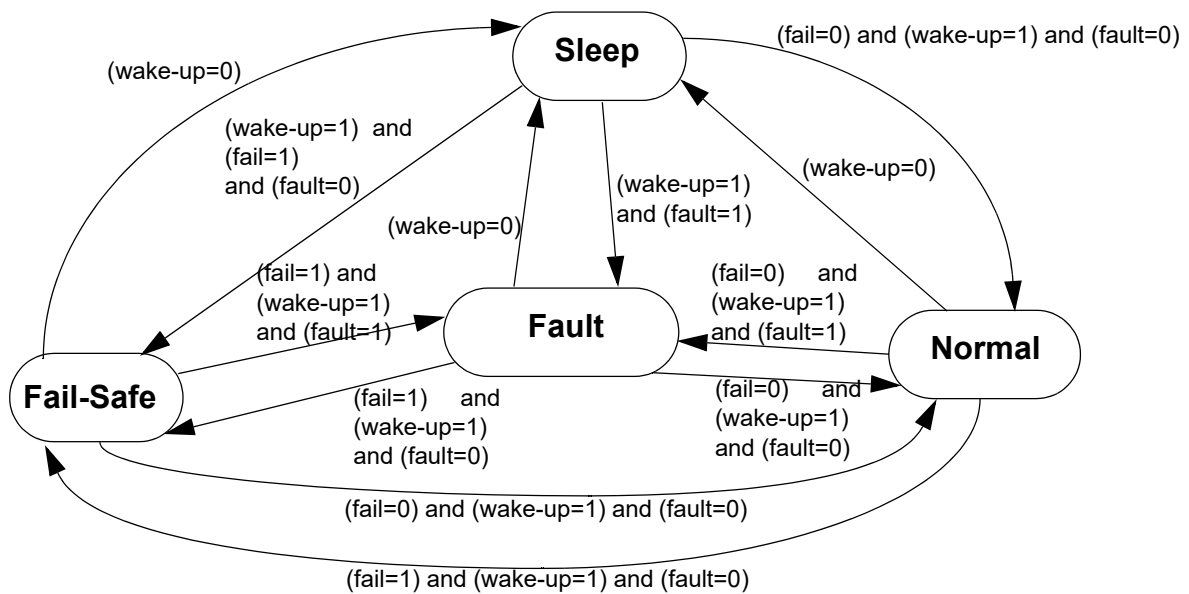

**Figure 12. Operating modes**

## 7.2.1 Sleep mode

The 15XS3400 is in Sleep mode when:

- $V_{PWR}$  and  $V_{DD}$  are within the normal voltage range,
- wake-up = 0,
- fail = X,
- fault = X.

This is the Default mode of the device after first applying battery voltage ( $V_{PWR}$ ) prior to any I/O transitions. This is also the state of the device when the WAKE and RST and IN\_ON[0:3] are logic [0]. In the Sleep mode, the output and all unused internal circuitry, such as the internal regulator, are off to minimize draw current. In addition, all SPI-configurable features of the device are as if set to logic [0].

## 7.2.2 Normal mode

The 15XS3400 is in Normal mode when:

- $V_{PWR}$  and  $V_{DD}$  are within the normal voltage range,
- wake-up = 1,
- fail = 0,
- fault = 0.

In this mode, the NM bit is set to `lfault_contrologic [1]` and the outputs HS[0:3] are under control, as defined by hson signal:

$$\text{hson}[x] = ( ( \text{IN}[x] \text{ and } \overline{\text{DIR\_dis}[x]} \text{ or } \text{On bit}[x] ) \text{ and } \overline{\text{PWM\_en}} ) \text{ or } ( \text{On bit}[x] \text{ and } \text{Duty\_cycle}[x] \text{ and } \overline{\text{PWM\_en}} )$$

In this mode and also in Fail-safe, the fault condition reset depends on fault\_control signal, as defined below:

$$\text{fault\_control}[x] = ( \text{IN\_ON}[x] \text{ and } \overline{\text{DIR\_dis}[x]} \text{ and } \overline{\text{PWM\_en}} ) \text{ or } ( \text{On bit}[x] )$$

### 7.2.2.1 Programmable PWM module

The outputs HS[0:3] are controlled by the programmable PWM module if PWM\_en and On bits are set to logic [1].

The clock frequency from IN0 input pin or from internal clock is the factor  $2^7$  (128) of the output PWM frequency (CLOCK\_sel bit). The outputs HS[0:3] can be controlled in the range of 5% to 98% with a resolution of 7 bits of duty cycle (Table 8). The state of other IN pin is ignored.

**Table 8. Output PWM resolution**

On bit	Duty cycle	Output state
0	X	OFF
1	0000000	PWM (1/128 duty cycle)
1	0000001	PWM (2/128 duty cycle)
1	0000010	PWM (3/128 duty cycle)
1	n	PWM ((n+1)/128 duty cycle)
1	1111111	fully ON

The timing includes seven programmable PWM switching delay (number of PWM clock rising edges) to improve overall EMC behavior of the light module (Table 9).

**Table 9. Output PWM switching delay**

Delay bits	Output delay
000	no delay
001	16 PWM clock periods
010	32 PWM clock periods
011	48 PWM clock periods
100	64 PWM clock periods
101	80 PWM clock periods
110	96 PWM clock periods
111	112 PWM clock periods

The clock frequency from IN0 is permanently monitored in order to report a clock failure in case of the frequency is out a specified frequency range (from  $f_{\text{IN0(LOW)}}$  to  $f_{\text{IN0(HIGH)}}$ ). In case of clock failure, no PWM feature is provided, the ON bit defines the outputs state and the CLOCK\_fail bit reports [1].

## 7.2.2.2 Calibratable internal clock

The internal clock can vary as much as +/-30 percent corresponding to typical  $f_{P_{WM(0)}}$  output switching period.

Using the existing SPI inputs and the precision timing reference already available to the MCU, the 15XS3400 allows clock period setting within  $\pm 10$  percent of accuracy. Calibrating the internal clock is initiated by defined word to CALR register. The calibration pulse is provided by the MCU. The pulse is sent on the CS pin after the SPI word is launched. At the moment, the CS pin transitions from logic [1] to [0] until from logic [0] to [1] determine the period of internal clock with a multiplicative factor of 128.

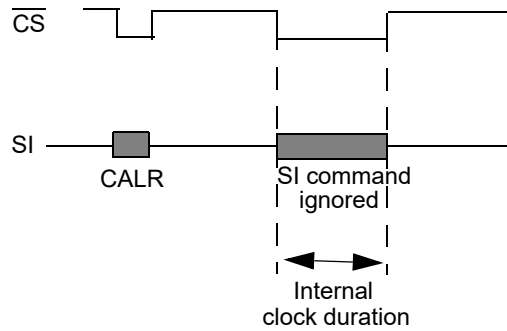

Figure 13. Internal clock calibration diagram

In case of negative CS pulse is outside a predefined time range (from  $t_{CSB(MIN)}$  to  $t_{CSB(MAX)}$ ), the calibration event will be ignored and the internal clock will be unaltered or reset to default value ( $f_{P_{WM(0)}}$ ) if this was not calibrated before.

The calibratable clock is used, instead of the clock from IN0 input, when CLOCK\_sel is set to [1].

## 7.2.3 Fail-safe mode

The 15XS3400 is in Fail-safe mode when:

- $V_{PWR}$  is within the normal voltage range,
- wake-up = 1,
- fail = 1,
- fault = 0.

### 7.2.3.1 Watchdog

If the FSI input is not grounded, the watchdog timeout detection is active when either the WAKE or IN\_ON[0:3] or RST input pin transitions from logic [0] to logic [1]. The WAKE input is capable of being pulled up to  $V_{PWR}$  with a series of limiting resistance limiting the internal clamp current according to the specification.

The watchdog timeout is a multiple of an internal oscillator. As long as the WD bit (D15) of an incoming SPI message is toggled within the minimum watchdog timeout period (WDTO), the device will operate normally.

## 7.2.3.2 Fail-safe conditions

If an internal watchdog timeout occurs before the WD bit for FSI open (Table 10) or in case of  $V_{DD}$  failure condition ( $V_{DD} < V_{DD(FAIL)}$ ) for VDD\_FAIL\_en bit is set to logic [1], the device will revert to a Fail-safe mode until the WD bit is written to logic [1] (see fail-safe to normal mode transition paragraph) and  $V_{DD}$  is within the normal voltage range.

**Table 10. SPI watchdog activation**

Typical RFSI ( $\Omega$ )	Watchdog
0 (shorted to ground)	Disabled
(open)	Enabled

During the Fail-safe mode, the outputs will depend on the corresponding input. The SPI register content is reset to their default value (except POR bit) and fault protections are fully operational.

The Fail-safe mode can be detected by monitoring the NM bit is set to [0].

## 7.2.4 Normal and Fail-safe mode transitions

### 7.2.4.1 Transition Fail-safe to Normal mode

To leave the Fail-safe mode,  $V_{DD}$  must be in nominal voltage and the microcontroller has to send a SPI command with WDIN bit set to logic [1]; the other bits are not considered. The previous latched faults are reset by the transition into Normal mode (autoretry included).

Moreover, the device can be brought out of the Fail-safe mode due to watchdog timeout issue by forcing the FSI pin to logic [0].

### 7.2.4.2 Transition Normal to Fail-safe mode

To leave the Normal mode, a fail-safe condition must occurred (fail=1). The previous latched faults are reset by the transition into Fail-safe mode (autoretry included).

## 7.2.5 Fault mode

The 15XS3400 is in Fault mode when:

- $V_{PWR}$  and  $V_{DD}$  are within the normal voltage range,
- wake-up = 1,
- fail = X,
- fault=1.

This device indicates the faults below as they occur by driving the  $\overline{FS}$  pin to logic [0] for  $\overline{RST}$  input is pulled up:

- Overtemperature fault,
- Overcurrent fault,
- Severe short-circuit fault,
- Output(s) shorted to VPWR fault in OFF state,
- Open load fault in OFF state,
- Overvoltage fault (enabled by default),
- Undervoltage fault.

The  $\overline{FS}$  pin will automatically return to logic [1] when the fault condition is removed, except for overcurrent, severe short-circuit, overtemperature and undervoltage which will be reset by a new turn-on command (each fault\_control signal to be toggled).

Fault information is retained in the SPI fault register and is available (and reset) via the SO pin during the first valid SPI communication.

The open load fault in ON state is only reported through SPI register without effect on the corresponding output state (HS[x]) and the  $\overline{FS}$  pin.

## 7.2.6 Start-up sequence

The 15XS3400 enters in Normal mode after start-up if following sequence is provided:

- VPWR and VDD power supplies must be above their undervoltage thresholds,
- generate wake-up event (wake-up=1) from 0 to 1 on RSTB. The device switches to Normal mode with SPI register content is reset (as defined in [Table 12](#) and [Table 24](#)). All features of 15XS3400 will be available after 50  $\mu$ s typical and all SPI registers are set to default values (set to logic [0]). The UV fault is reported in the SPI status registers.

And, in case of the PWM module is used (PWM\_en bit is set to logic [1]) with an external reference clock:

- apply PWM clock on IN0 input pin after maximum 200  $\mu$ s (min. 50  $\mu$ s).

If the correct start-up sequence is not provided, the PWM function is not guaranteed.

## 7.3 Protection and diagnostic features

### 7.3.1 Protections

#### 7.3.1.1 Overtemperature fault

The 15XS3400 incorporates overtemperature detection and shutdown circuitry for each output structure.

Two cases need to be considered when the output temperature is higher than  $T_{SD}$ :

- If the output command is ON: the corresponding output is latched OFF.  $\overline{FS}$  will be also latched to logic [0]. To delatch the fault and be able to turn ON again the outputs, the failure condition must disappear and the autoretry circuitry must be active or the corresponding output must be commanded OFF and then ON (toggling fault\_control signal of corresponding output) or  $V_{SUPPLY(POR)}$  condition if  $V_{DD} = 0$ .
- If the output command is OFF:  $\overline{FS}$  will go to logic [0] till the corresponding output temperature will be below  $T_{SD}$ .

For both cases, the fault register OT[0:3] bit into the status register will be set to [1]. The fault bits will be cleared in the status register after a SPI read command.

#### 7.3.1.2 Overcurrent fault

The 15XS3400 incorporates output shutdown in order to protect each output structure against resistive short-circuit condition. This protection is composed by eight predefined current levels (time dependent) to fit Xenon-HID manners by default or, 55 W or 28 W bulb profiles, selectable separately by  $\overline{Xenon}$  bit and 28 W bits (as illustrated [Figure 17](#), page 40).

In the first turn-on, the lamp filament is cold and the current will be huge. fault\_control signal transition from logic [0] to [1] or an autoretry define this event. In this case, the overcurrent protection will be fitted to inrush current, as shown in [Figure 5](#). This overcurrent protection is programmable: OC[1:0] bits select overcurrent slope speed and OCHI1 current step can be removed in case of OCHI bit is set to [1].

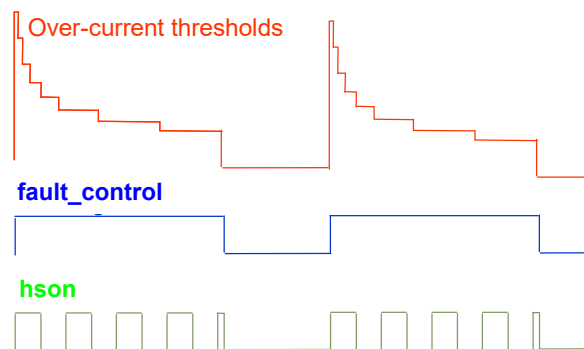

Figure 14. Overcurrent detection profile

In steady state, the wire harness will be protected by OCLO2 current level by default. Three other DC overcurrent levels are available: OCLO1 or OCLO3 or OCLO4 based on the state of the OCLO[1,0] bits.



If the load current level ever reaches the overcurrent detection level, the corresponding output will latch the output OFF and  $\overline{FS}$  will be also latched to logic [0]. To delatch the fault and be able to turn ON again the corresponding output, the failure condition must disappear and the autoretry circuitry must be active or the corresponding output must be commanded OFF and then ON (toggling fault\_control signal of corresponding output) or  $V_{SUPPLY(POR)}$  condition if  $V_{DD} = 0$ .

The SPI fault report (OC[0:3] bits) is removed after a read operation.

In Normal mode using internal PWM module, the 15XS3400 incorporates also a cooling bulb filament management if OC\_mode and  $\overline{Xenon}$  are set to logic [1]. In this case, the 1<sup>st</sup> step of multi-step overcurrent protection will depend to the previous OFF duration, as illustrated in Figure 6. The following figure illustrates the current level will be used in function to the duration of previous OFF state (toff). The slope of cooling bulb emulator is configurable with OCOFFCB[1:0] bits.

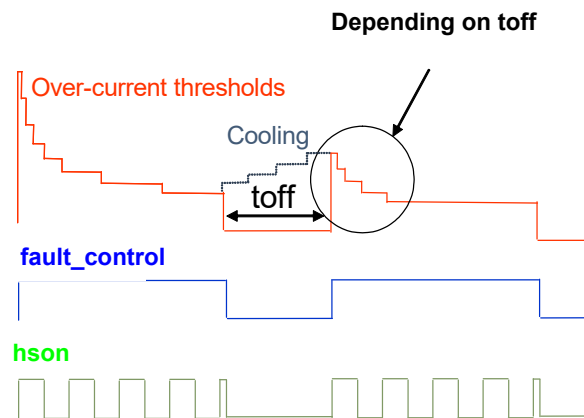

Figure 15. Bulb cooling principle

### 7.3.1.3 Severe short-circuit fault

The 15XS3400 provides output shutdown in order to protect each output in case of severe short-circuit during of the output switching.

If the short-circuit impedance is below  $R_{SHORT}$ , the device will latch the output OFF,  $\overline{FS}$  will go to logic [0] and the fault register SC[0:3] bit will be set to [1]. To delatch the fault and be able to turn ON again the outputs, the failure condition must disappear and the corresponding output must be commanded OFF and then ON (toggling fault\_control signal of corresponding output) or  $V_{SUPPLY(POR)}$  condition if  $V_{DD} = 0$ .

The SPI fault report (SC[0:3] bits) is removed after a read operation.

### 7.3.1.4 Overvoltage fault (enabled by default)

By default, the overvoltage protection is enabled. The 15XS3400 shuts down all outputs and  $\overline{FS}$  will go to logic [0] during an overvoltage fault condition on the VPWR pin ( $V_{PWR} \geq V_{PWR(OV)}$ ). The outputs remain in the OFF state until the overvoltage condition is removed ( $V_{PWR} \leq V_{PWR(OV)} - V_{PWR(OVHYS)}$ ). When experiencing this fault, the OVF fault bit is set to logic [1] and cleared after either a valid SPI read.

The overvoltage protection can be disabled through SPI (OV\_dis bit is disabled set to logic [1]). The fault register reflects any overvoltage condition ( $V_{PWR} \geq V_{PWR(OV)}$ ). This overvoltage diagnosis, as a warning, is removed after a read operation, if the fault condition disappears. The HS[0:3] outputs are not commanded in  $R_{DS(ON)}$  above the OV threshold.

In Fail-safe mode, the overvoltage activation depends on the  $\overline{RST}$  logic state; enable for  $\overline{RST} = 1$  and disable for  $\overline{RST} = 0$ . The device is still protected with overtemperature protection in case the overvoltage feture is disabled.

### 7.3.1.5 Undervoltage fault

The output(s) will latch off at some battery voltage below  $V_{PWR(UV)}$ . As long as the  $V_{DD}$  level stays within the normal specified range, the internal logic states within the device will remain (configuration and reporting).

In the case where battery voltage drops below the undervoltage threshold ( $V_{PWR} \leq V_{PWR(UV)}$ ), the outputs will turn off,  $\overline{FS}$  will go to logic [0], and the fault register UV bit will be set to [1].

Two cases need to be considered when the battery level recovers ( $V_{PWR} > V_{PWR(UV\_UP)}$ ):

- If outputs command are low,  $\overline{FS}$  will go to logic [1] but the UV bit will remain set to 1 until the next read operation (warning report).
- If the output command is ON,  $\overline{FS}$  will remain at logic [0]. To delatch the fault and be able to turn ON again the outputs, the failure condition must disappear and the autoretry circuitry must be active or the corresponding output must be commanded OFF and then ON (toggling fault\_control signal of corresponding output) or  $V_{SUPPLY(POR)}$  condition if  $V_{DD} = 0$ .

In **extended mode**, the output is protected by overtemperature shutdown circuitry. All previous latched faults, occurred when VPWR was within the normal voltage range, are guaranteed if VDD is within the operational voltage range or until  $V_{SUPPLY(POR)}$  if  $V_{DD} = 0$ . Any new OT fault is detected (VDD failure included) and reported through SPI above  $VPWR_{(UV)}$ . The output state is not changed as long as the VPWR voltage does not drop any lower than 3.5V typical.

All latched faults (overtemperature, overcurrent, severe short-circuit, over and undervoltage) are reset if :

- $V_{DD} \leq V_{DD(FAIL)}$  with  $V_{PWR}$  in nominal voltage range,
- $V_{DD}$  and  $V_{PWR}$  supplies is below  $V_{SUPPLY(POR)}$  voltage value.

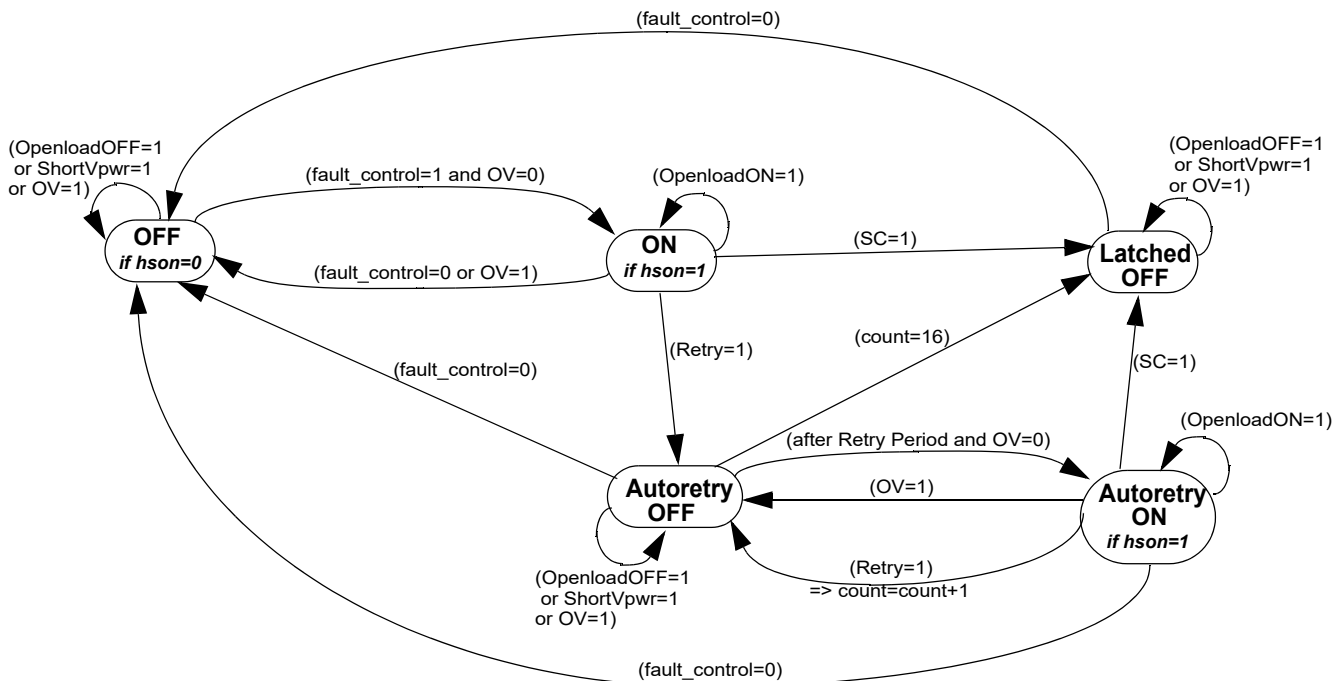

Figure 16. Autoretry state machine

## 7.3.2 Autoretry

The autoretry circuitry is used to reactivate the output(s) automatically in case of overcurrent or overtemperature or undervoltage failure conditions to provide a high availability of the load.

Autoretry feature is available in Fault mode. It is activated in case of internal retry signal is set to logic [1]:

$retry[x] = OC[x] \text{ or } OT[x] \text{ or } UV$ .

The feature retries to switch-on the output(s) after one autoretry period ( $t_{AUTO}$ ) with a limitation in term of number of occurrence (16 for each output). The counter of retry occurrences is reset in case of Fail-safe to Normal or Normal to Fail-safe mode transitions. At each autoretry, the overcurrent detection will be set to default values in order to sustain the inrush current.

The [Figure 16](#) describes the autoretry state machine.

## 7.3.3 Diagnostic

### 7.3.3.1 Output shorted to VPWR fault

The 15XS3400 incorporates output shorted to VPWR detection circuitry in OFF state. Output shorted to VPWR fault is detected if output voltage is higher than  $V_{OSD(THRES)}$  and reported as a fault condition when the output is disabled (OFF). The output shorted to VPWR fault is latched into the status register after the internal gate voltage is pulled low enough to turn OFF the output. The OS[0:3] and OL\_OFF[0:3] fault bits are set in the status register and FS pin reports in real time the fault. If the output shorted to VPWR fault is removed, the status register will be cleared after reading the register.

The open output shorted to VPWR protection can be disabled through SPI (OS\_DIS[0:3] bit).

### 7.3.3.2 Openload faults

The 15XS3400 incorporates three dedicated open-load detection circuitries on output to detect OFF and ON state.

### 7.3.3.3 Openload detection In OFF state

The OFF output open-load fault is detected when the output voltage is higher than  $V_{OLD(THRES)}$  pulled up with internal current source ( $I_{OLD(OFF)}$ ) and reported as a fault condition when the output is disabled (OFF). The OFF Output open-load fault is latched into the status register or when the internal gate voltage is pulled low enough to turn OFF the output. The OL\_OFF[0:3] fault bit is set in the status register. If the open load fault is removed (FS output pin goes to high), the status register will be cleared after reading the register.

The OFF output open-load protection can be disabled through SPI (OLOFF\_DIS[0:3] bit).

### 7.3.3.4 Openload detection in ON State

The ON output open-load current thresholds can be chosen by SPI to detect a standard bulbs or LEDs (OLLED[0:3] bit set to logic [1]). In cases where the load current drops below the defined current threshold, the OLON bit will be set to a logic [1], the output will stay ON and FS will not be disturbed.

### 7.3.3.5 Openload detection in ON state for LED

Open load for LEDs only (OLLED[0:3] set to logic [1]) is detected periodically each  $t_{OLLED}$  (fully-on, D[7:0]=FF). To detect OLLED in fully-on state, the output must be ON at least  $t_{OLLED}$  and PWM module must be enabled (PWM\_en = 1 in GCR register).

To delatch the diagnosis, the condition should be removed and SPI read operation is needed (OL\_ON[0:3] bit). The ON output open-load protection can be disabled through SPI (OLON\_DIS[0:3] bit).

## 7.3.4 Analog current recopy and temperature feedback

The CSNS pin is an analog output reporting a current proportional to the designed output current or a voltage proportional to the temperature of the GND flag (pin #14). The routing is SPI programmable (TEMP\_en, CSNS\_en, CSNS\_s[1,0] and CSNS\_ratio\_s bits).

In case the current recopy is active, the CSNS output delivers current only during ON time of the output switch without overshoot. The maximum current is 2.0 mA typical. The typical value of external CSNS resistor connected to the ground is 4.7 kΩ.

The current recopy is not active in Fail-safe mode.

### 7.3.4.1 Temperature prewarning detection

In Normal mode, the 15XS3400 provides a temperature prewarning reported via SPI in case of the temperature of the GND flag is higher than  $T_{OTWAR}$ . This diagnosis (OTW bit set to [1]) is latched in the SPI DIAGR0 register. To delatch, a read SPI command is needed.

## 7.3.5 Active clamp on VPWR

The device provides an active gate clamp circuit in order to limit the maximum transient VPWR voltage at  $VPWR_{(CLAMP)}$ . In case of overload on an output the corresponding output is turned off which leads to high-voltage at VPWR with an inductive VPWR line. When VPWR voltage exceeds  $VPWR_{(CLAMP)}$  threshold, the turn-off on the corresponding output is deactivated and all HS[0:3] outputs are switched ON automatically to demagnetize the inductive Battery line.

For a long battery line between the battery and the device (> 20 meters), the smart high-side switch output may exceed the energy capability in case of a short-circuit. It is recommended to implement a voltage transient suppressor to drain the battery line energy.

## 7.3.6 Reverse battery on VPWR

The output survives the application of reverse voltage as low as -18 V. Under these conditions, the ON resistance of the output is 2 times higher than typical ohmic value in forward mode. No additional passive components are required except on  $V_{DD}$  current path.

## 7.3.7 Ground disconnect protection

In the event the 15XS3400 ground is disconnected from load ground, the device protects itself and safely turns OFF the output regardless of the state of the output at the time of disconnection (maximum VPWR=16 V). A 10 k $\Omega$  resistor needs to be added between the MCU and each digital input pin in order to ensure that the device turns off in case of ground disconnect and to prevent this pin from exceeding maximum ratings.

## 7.3.8 Loss of supply lines

### 7.3.8.1 Loss of VDD

If the external  $V_{DD}$  supply is disconnected (or not within specification:  $V_{DD} < V_{DD(FAIL)}$ ) with VDD\_FAIL\_en bit is set to logic [1], all SPI register content is reset.

The outputs can still be driven by the direct inputs IN[0:3] if  $V_{PWR}$  is within specified voltage range. The 15XS3400 uses the battery input to power the output MOSFET-related current sense circuitry and any other internal logic providing Fail-safe device operation with no  $V_{DD}$  supplied. In this state, the overtemperature, overcurrent, severe short-circuit, short to VPWR and OFF open-load circuitry are fully operational with default values corresponding to all SPI bits are set to logic [0]. No current is conducted from VPWR to  $V_{DD}$ .

### 7.3.8.2 Loss of VPWR

If the external VPWR supply is disconnected (or not within specification), the SPI configuration, reporting and daisy chain features are provided for RST is set to logic [1] under  $V_{DD}$  in nominal conditions. This fault condition can be diagnosed with a UV fault in the SPI STATR\_s registers. The SPI pull-up and pull-down current sources are not operational. The previous device configuration is maintained. No current is conducted from VDD to VPWR.

### 7.3.8.3 Loss of VPWR and VDD

If the external VPWR and VDD supplies are disconnected (or not within specification:  $(V_{DD} \text{ and } VPWR) < V_{SUPPLY(POR)}$ ), all SPI register contents are reset with default values corresponding to all SPI bits are set to logic [0] and all latched faults are also reset.

## 7.3.9 EMC performances

All following tests are performed on NXP evaluation board in accordance with the typical application schematic.

The device is protected in case of positive and negative transients on the VPWR line (per ISO 7637-2).

The 15XS3400 successfully meets the Class 5 of the CISPR25 emission standard and 200 V/m or BCI 200 mA injection level for immunity tests.

## 7.4 Logic commands and registers

### 7.4.1 Serial input communication

SPI communication is accomplished using 16-bit messages. A message is transmitted by the MCU starting with the MSB D15 and ending with the LSB, D0 (Table 11). Each incoming command message on the SI pin can be interpreted using the following bit assignments: the MSB, D15, is the watchdog bit (WDIN). In some cases, output selection is done with bits D14:D13. The next three bits, D12:D10, are used to select the command register. The remaining nine bits, D8:D0, are used to configure and control the outputs and their protection features.

Multiple messages can be transmitted in succession to accommodate those applications where daisy-chaining is desirable, or to confirm transmitted data, as long as the messages are all multiples of 16 bits. Any attempt made to latch in a message that is not 16 bits will be ignored.

The 15XS3400 has defined registers, which are used to configure the device and to control the state of the outputs. Table 12 summarizes the SI registers.

**Table 11. SI message bit assignment**

Bit sig	SI msg Bit	Message bit description
MSB	D15	Watchdog in: toggled to satisfy watchdog requirements.
	D14:D13	Register address bits used in some cases for output selection (Table 12).
	D12:D10	Register address bits.
	D9	Not used (set to logic [0]).
LSB	D8:D0	Used to configure the inputs, outputs, and the device protection features and SO status content.

**Table 12. Serial input address and configuration bit map**

SI Register	SI Data															
	D15	D14	D13	D12	D11	D10	D9	D8	D7	D6	D5	D4	D3	D2	D1	D0
STATR_s	WDIN	X	X	0	0	0	0	0	0	0	0	SOA4	SOA3	SOA2	SOA1	SOA0
PWMR_s	WDIN	A <sub>1</sub>	A <sub>0</sub>	0	0	1	0	28W_s	ON_s	PWM6_s	PWM5_s	PWM4_s	PWM3_s	PWM2_s	PWM1_s	PWM0_s
CONFR0_s	WDIN	A <sub>1</sub>	A <sub>0</sub>	0	1	0	0	0	0	0	DIR_dis_s	SR1_s	SR0_s	DELAY2_s	DELAY1_s	DELAY0_s
CONFR1_s	WDIN	A <sub>1</sub>	A <sub>0</sub>	0	1	1	0	0	0	Retry_unlimited_s	Retry_dis_s	OS_dis_s	OLON_dis_s	OLOFF_dis_s	OLLED_en_s	CSNS_ratio_s
OCR_s	WDIN	A <sub>1</sub>	A <sub>0</sub>	1	0	0	0	Xenon_s	BC1_s	BC0_s	OC1_s	OC0_s	OCHI_s	OCL01_s	OCLCO0_s	OC_mode_s
GCR	WDIN	0	0	1	0	1	0	VDD_FAIL_en	PWM_en	CLOCK_sel	TEMP_en	CSNS_en	CSNS1	CSNS0	X	OV_dis
CALR	WDIN	0	0	1	1	1	0	1	0	1	0	1	1	0	1	1
<i>Register state after RST=0 or V<sub>DD</sub>(FAIL) or V<sub>SUPPLY</sub>(POR) condition</i>	0	0	0	X	X	X	0	0	0	0	0	0	0	0	0	0

x=Don't care.

s=Output selection with the bits A<sub>1</sub>A<sub>0</sub> as defined in Table 13.

### 7.4.2 Device register addressing

The following section describes the possible register addresses (D[14:10]) and their impact on device operation.

### 7.4.2.1 Address XX000—Status register (STATR\_S)

The STATR register is used to read the device status and the various configuration register contents without disrupting the device operation or the register contents. The register bits D[4:0] determine the content of the first sixteen bits of SO data. In addition to the device status, this feature provides the ability to read the content of the PWMR\_s, CONFR1\_s, OCR\_s, GCR and CALR registers (see [Serial output communication \(device status return data\)](#)).

### 7.4.2.2 Address A<sub>1</sub>A<sub>0</sub>001—Output PWM control register (PWMR\_S)

The PWMR\_s register allows the MCU to control the state of corresponding output through the SPI. Each output “s” is independently selected for configuration based on the state of the D14:D13 bits ([Table 13](#)).

**Table 13. Output selection**

A <sub>1</sub> (D14)	A <sub>0</sub> (D13)	HS Selection
0	0	HS0 (default)
0	1	HS1
1	0	HS2
1	1	HS3

A logic [1] on bit D8 (28W\_s) selects the 28 W overcurrent protection profile: the overcurrent thresholds are divided by 2 and, the inrush and cooling responses are dedicated to 28 W lamp.

Bit D7 sets the output state. A logic [1] enables the corresponding output switch and a logic [0] turns it OFF (if IN input is also pulled down). Bits D6:D0 set the output PWM duty-cycle to one of 128 levels for PWM\_en is set to logic [1], as shown [Table 8](#), page [29](#).

### 7.4.2.3 Address A<sub>1</sub>A<sub>0</sub>010—Output configuration register (CONFR0\_S)

The CONFR0\_s register allows the MCU to configure corresponding output switching through the SPI. Each output “s” is independently selected for configuration based on the state of the D14:D13 bits ([Table 13](#)).

For the selected output, a logic [0] on bit D5 (DIR\_DIS\_s) will enable the output for direct control. A logic [1] on bit D5 will disable the output from direct control (in this case, the output is only controlled by On bit).

D4:D3 bits (SR1\_s and SR0\_s) are used to select the high or medium or low speed slew rate for the selected output, the default value [00] corresponds to the medium speed slew rate ([Table 14](#)).

**Table 14. Slew rate speed selection**

SR1_s (D4)	SR0_s (D3)	Slew rate speed
0	0	medium (default)
0	1	low
1	0	high
1	1	Not used

Incoming message bits D2:D0 reflect the desired output that will be delayed of predefined PWM clock rising edges number, as shown [Table 9](#), page [29](#) (only available for PWM\_en bit is set to logic [1]).

### 7.4.2.4 Address A<sub>1</sub>A<sub>0</sub>011—Output configuration register (CONFR1\_S)

The CONFR1\_s register allows the MCU to configure corresponding output fault management through the SPI. Each output “s” is independently selected for configuration based on the state of the D14:D13 bits ([Table 13](#)).

A logic [1] on bit D6 (RETRY\_unlimited\_s) disables the autoretry counter for the selected output, the default value [0] corresponds to enable autoretry feature without time limitation.

A logic [1] on bit D5 (RETRY\_dis\_s) disables the autoretry for the selected output, the default value [0] corresponds to enable this feature.

A logic [1] on bit D4 (OS\_dis\_s) disables the output hard shorted to VPWR protection for the selected output, the default value [0] corresponds to enable this feature.

A logic [1] on bit D3 (OLON\_dis\_s) disables the ON output open-load detection for the selected output, the default value [0] corresponds to enable this feature (Table 15).

A logic [1] on bit D2 (OLOFF\_dis\_s) disables the OFF output open-load detection for the selected output, the default value [0] corresponds to enable this feature.

A logic [1] on bit D1 (OLLED\_en\_s) enables the ON output open-load detection for LEDs for the selected output, the default value [0] corresponds to ON output openload detection is set for bulbs (Table 15).

**Table 15. ON openload selection**

OLON_dis_s (D3)	OLLED_en_s (D1)	ON openload detection
0	0	enable with bulb threshold (default)
0	1	enable with LED threshold
1	X	disable

A logic [1] on bit D0 (CSNS\_ratio\_s) selects the high ratio on the CSNS pin for the corresponding output. The default value [0] is the low ratio (Table 16).

**Table 16. Current sense ratio selection**

CSNS_high_s (D0)	Current sense ratio
0	CRS0 (default)
1	CRS1

#### 7.4.2.5 Address A<sub>1</sub>A<sub>0</sub>100—Output overcurrent register (OCR)

The OCR\_s register allows the MCU to configure corresponding output overcurrent protection through the SPI. Each output “s” is independently selected for configuration based on the state of the D14:D13 bits (Table 13).

A logic [1] on bit D8 (Xenon\_s) enables the bulb overcurrent profile, as described Figure 17.

Xenon bit set to logic [0]:

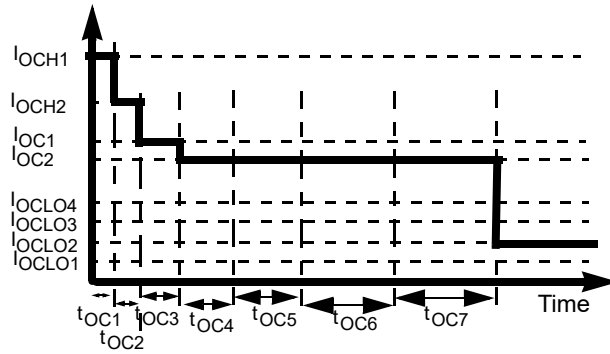

Xenon bit set to logic [1]:

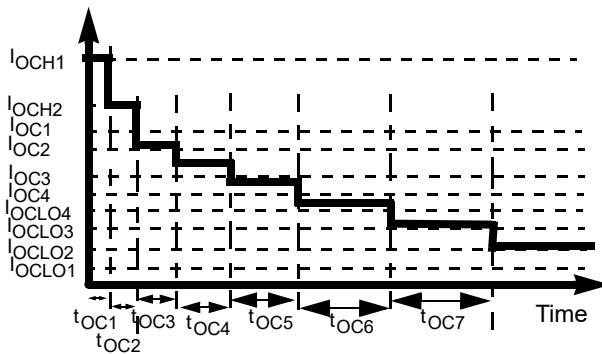

Figure 17. Overcurrent profile depending on Xenon bit

D[7:6] bits allow to MCU to programmable bulb cooling curve and D[5:4] bits inrush curve for selected output, as shown [Table 17](#) and [Table 18](#).

Table 17. Cooling and inrush curve selection

BC1_s (D7)	BC0_s (D6)	Profile curves speed
0	0	medium (default)
0	1	slow
1	0	fast
1	1	medium

Table 18. Inrush curve selection

OC1_s (D5)	OC0_s (D4)	Profile curves speed
0	0	slow (default)
0	1	fast
1	0	medium
1	1	very slow

A logic [1] on bit D3 (OCHI\_s bit) the OCHI1 level is replaced by OCHI2 during  $t_{OC1}$ , as shown [Figure 18](#).



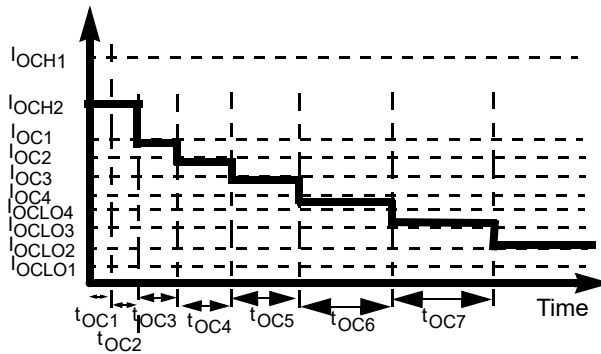

**Figure 18. Overcurrent profile with OCHI bit set to '1'**

The wire harness is protected by one of four possible current levels in steady state, as defined in [Table 19](#).

**Table 19. Output steady state selection**

OCLO1 (D2)	OCLO0 (D1)	Steady state current
0	0	OCLO2 (default)
0	1	OCLO3
1	0	OCLO4
1	1	OCLO1

Bit D0 (OC\_mode\_sel) allows to select the overcurrent mode, as described [Table 20](#).

**Table 20. Overcurrent mode selection**

OC_mode_s (D0)	Overcurrent mode
0	only inrush current management (default)
1	inrush current and bulb cooling management

### 7.4.2.6 Address 00101—Global configuration register (GCR)

The GCR register allows the MCU to configure the device through the SPI.

Bit D8 allows the MCU to enable or disable the  $V_{DD}$  failure detector. A logic [1] on VDD\_FAIL\_en bit allows transitioning to Fail-safe mode for  $V_{DD} < V_{DD(FAIL)}$ .

Bit D7 allows the MCU to enable or disable the PWM module. A logic [1] on PWM\_en bit allows control of the outputs HS[0:3] with PWMR register (the direct input states are ignored).

Bit D6 (CLOCK\_sel) allows to select the clock used as reference by PWM module, as described in the following [Table 21](#).

**Table 21. PWM module selection**

PWM_en (D7)	CLOCK_sel (D6)	PWM module
0	X	PWM module disabled (default)
1	0	PWM module enabled with external clock from IN0
1	1	PWM module enabled with internal calibrated clock

Bits D5:D4 allow the MCU to select one of two analog feedback on CSNS output pin, as shown in [Table 22](#).

**Table 22. CSNS reporting selection**

TEMP_en (D5)	CSNS_en (D4)	CSNS reporting
0	0	CSNS tri-stated (default)
X	1	current recopy of selected output (D3:2) bits)
1	0	temperature on GND flag

**Table 23. Output current recopy selection**

CSNS1 (D3)	CSNS0 (D2)	CSNS reporting
0	0	HS0 (default)
0	1	HS1
1	0	HS2
1	1	HS3

The GCR register disables the overvoltage protection (D0). When this bits is [0], the overvoltage is enabled (default value).

### 7.4.2.7 Address 00111—Calibration register (CALR)

The CALR register allows the MCU to calibrate internal clock, as explained in [Figure 16](#).

### 7.4.3 Serial output communication (device status return data)

When the  $\overline{CS}$  pin is pulled low, the output register is loaded. Meanwhile, the data is clocked out MSB- (OD15-) first as the new message data is clocked into the SI pin. The first sixteen bits of data clocking out of the SO, and following a  $\overline{CS}$  transition, is dependent upon the previously written SPI word.

Any bits clocked out of the Serial Output (SO) pin after the first 16 bits will be representative of the initial message bits clocked into the SI pin since the  $\overline{CS}$  pin first transitioned to a logic [0]. This feature is useful for daisy-chaining devices as well as message verification.

A valid message length is determined following a  $\overline{CS}$  transition of [0] to [1]. If there is a valid message length, the data is latched into the appropriate registers. A valid message length is a multiple of 16 bits. At this time, the SO pin is tri-stated and the fault status register is now able to accept new fault status information.

SO data will represent information ranging from fault status to register contents, user selected by writing to the STATR bits OD4, OD3, OD2, OD1, and OD0. The value of the previous bits SOA4 and SOA3 will determine which output the SO information applies to for the registers which are output specific; viz., Fault, PWMR, CONFR0, CONFR1 and OCR registers.

Note that the SO data will continue to reflect the information for each output (depending on the previous SOA4, SOA3 state) that was selected during the most recent STATR write until changed with an updated STATR write.

The output status register correctly reflects the status of the STATR-selected register data at the time that the  $\overline{CS}$  is pulled to a logic [0] during SPI communication, and/or for the period of time since the last valid SPI communication, with the following exception:

- The previous SPI communication was determined to be invalid. In this case, the status will be reported as though the invalid SPI communication never occurred.
- The VPWR voltage is below 4.0 V, the status must be ignored by the MCU.

### 7.4.4 Serial output bit assignment

The 16 bits of serial output data depend on the previous serial input message, as explained in the following paragraphs. [Table 24](#), summarizes SO returned data for bits OD15:OD0.

- Bit OD15 is the MSB; it reflects the state of the Watchdog bit from the previously clocked-in message.
- Bits OD14:OD10 reflect the state of the bits SOA4:SOA0 from the previously clocked in message.
- Bit OD9 is set to logic [1] in Normal mode (NM).
- The contents of bits OD8:OD0 depend on bits D4:D0 from the most recent STATR command SOA4:SOA0 as explained in the paragraphs following [Table 24](#).

**Table 24. Serial output bit map description**

	Previous STATR					SO Returned Data															
	SO A4	SO A3	SO A2	SO A1	SO A0	OD 15	OD 14	OD 13	OD 12	OD 11	OD 10	OD9	OD8	OD7	OD6	OD5	OD4	OD3	OD2	OD1	OD0
STATR_s	A <sub>1</sub>	A <sub>0</sub>	0	0	0	WDIN	SOA4	SOA3	SOA2	SOA1	SOA0	NM	POR	UV	OV	OLON_s	OLOFF_s	OS_s	OT_s	SC_s	OC_s
PWMR_s	A <sub>1</sub>	A <sub>0</sub>	0	0	1	WDIN	SOA4	SOA3	SOA2	SOA1	SOA0	NM	28W_s	ON_s	PWM6_s	PWM5_s	PWM4_s	PWM3_s	PWM2_s	PWM1_s	PWM0_s
CONFR0_s	A <sub>1</sub>	A <sub>0</sub>	0	1	0	WDIN	SOA4	SOA3	SOA2	SOA1	SOA0	NM	X	X	X	DIR_dis_s	SR1_s	SR0_s	DELAY2_s	DELAY1_s	DELAY0_s
CONFR1_s	A <sub>1</sub>	A <sub>0</sub>	0	1	1	WDIN	SOA4	SOA3	SOA2	SOA1	SOA0	NM	X	X	Retry_unlimited_s	Retry_dis_s	OS_dis_s	OLON_dis_s	OLOFF_dis_s	OLLED_en_s	CSNS_ratio_s
OCR_s	A <sub>1</sub>	A <sub>0</sub>	1	0	0	WDIN	SOA4	SOA3	SOA2	SOA1	SOA0	NM	Xenon_s	BC1_s	BC0_s	OC1_s	OC0_s	OCHI_s	OCLO1_s	OCLO0_s	OC_mode_s
GCR	0	0	1	0	1	WDIN	SOA4	SOA3	SOA2	SOA1	SOA0	NM	VDD_FAIL_en	PWM_en	CLOCK_sel	TEMP_en	CSNS_en	CSNS1	CSNS0	X	OV_dis
DIAGR0	0	0	1	1	1	WDIN	SOA4	SOA3	SOA2	SOA1	SOA0	NM	X	X	X	X	X	X	CLOCK_fail	CAL_fail	OTW
DIAGR1	0	1	1	1	1	WDIN	SOA4	SOA3	SOA2	SOA1	SOA0	NM	X	X	X	X	IN3	IN2	IN1	IN0	WD_en
DIAGR2	1	0	1	1	1	WDIN	SOA4	SOA3	SOA2	SOA1	SOA0	NM	X	X	X	X	X	X	0	1	0
Register state after RST=0 or V <sub>DD(FAIL)</sub> or V <sub>SUPPLY(POR)</sub> condition	N/A	N/A	N/A	N/A	N/A	0	0	0	0	0	0	0	0	X	0	0	0	0	0	0	0

s=Output selection with the bits A<sub>1</sub>A<sub>0</sub> as defined in [Table 13](#)

#### 7.4.4.1 Previous address SOA4:SOA0=A<sub>1</sub>A<sub>0</sub>000 (STATR\_S)

The returned data OD8 reports logic [1] in case of previous power-on reset condition (V<sub>SUPPLY(POR)</sub>). This bit is only reset by a read operation.

Bits OD7:OD0 reflect the current state of the Fault register (FLTR) corresponding to the output previously selected with the bits SOA4:SOA3 = A<sub>1</sub>A<sub>0</sub> ([Table 24](#)).

- OC\_s: overcurrent fault detection for a selected output,
- SC\_s: severe short-circuit fault detection for a selected output,
- OS\_s: output shorted to VPWR fault detection for a selected output,
- OLOFF\_s: openload in OFF state fault detection for a selected output,
- OLON\_s: openload in ON state fault detection (depending on current level threshold: bulb or LED) for a selected output,
- OV: overvoltage fault detection,
- UV: undervoltage fault detection
- POR: power-on reset detection.

The  $\overline{FS}$  pin reports all faults. For latched faults, this pin is reset by a new Switch OFF command (toggling fault\_control signal).

#### 7.4.4.2 Previous address SOA4:SOA0=A<sub>1</sub>A<sub>0</sub>001 (PWMR\_S)

The returned data contains the programmed values in the PWMR register for the output selected with A<sub>1</sub>A<sub>0</sub>.

#### 7.4.4.3 Previous address SOA4:SOA0=A<sub>1</sub>A<sub>0</sub>010 (CONFR0\_S)

The returned data contains the programmed values in the CONFR0 register for the output selected with A<sub>1</sub>A<sub>0</sub>.

#### 7.4.4.4 Previous address SOA4:SOA0=A<sub>1</sub>A<sub>0</sub>011 (CONFR1\_S)

The returned data contains the programmed values in the CONFR1 register for the output selected with A<sub>1</sub>A<sub>0</sub>.

#### 7.4.4.5 Previous address SOA4:SOA0=A<sub>1</sub>A<sub>0</sub>100 (OCR\_S)

The returned data contains the programmed values in the OCR register for the output selected with A<sub>1</sub>A<sub>0</sub>.

#### 7.4.4.6 Previous address SOA4:SOA0=00101 (GCR)

The returned data contains the programmed values in the GCR register.

#### 7.4.4.7 Previous address SOA4:SOA0=00111 (DIAGR0)

The returned data OD2 reports logic [1] in case of PWM clock on IN0 pin is out of specified frequency range.

The returned data OD1 reports logic [1] in case of calibration failure.

The returned data OD0 reports logic [1] in case of overtemperature prewarning (temperature of GND flag is above T<sub>OTWAR</sub>).

#### 7.4.4.8 Previous address SOA4:SOA0=01111 (DIAGR1)

The returned data OD4: OD1 report in real time the state of the direct input IN[3:0].

The OD0 indicates if the watchdog is enabled (set to logic [1]) or not (set to logic [0]). OD4:OD1 report the output state in case of Fail-safe state due to watchdog timeout as explained in the following [Table 25](#).

**Table 25. Watchdog activation report**

WD_en (OD0)	SPI watchdog
0	disabled
1	enabled

#### 7.4.4.9 Previous address SOA4:SOA0=10111 (DIAGR2)

The returned data is the product ID. Bits OD2:OD0 are set to 010 for protected quad 15 mΩ high-side switches.

### 7.4.5 Default device configuration

The default device configuration is explained below:

- HS output is commanded by corresponding IN input or ON bit through SPI. The medium slew-rate is used,
- HS output is fully protected by the Xenon overcurrent profile by default, the severe short-circuit protection, the undervoltage and the overtemperature protection. The autoretry feature is enabled,
- Openload in ON and OFF state and HS shorted to VPWR detections are available,
- No current recopy and no analog temperature feedback active,
- Overvoltage protection is enabled,
- SO reporting fault status from HS0,
- VDD failure detection is disabled.

## 8 Typical applications

The following figure shows a typical automotive lighting application (only one vehicle corner) using an external PWM clock from the main MCU. A redundancy circuitry has been implemented to substitute light control (from MCU to watchdog) in case of a Fail-safe condition.

It is recommended to locate a 22 nF decoupling capacitor to the module connector.

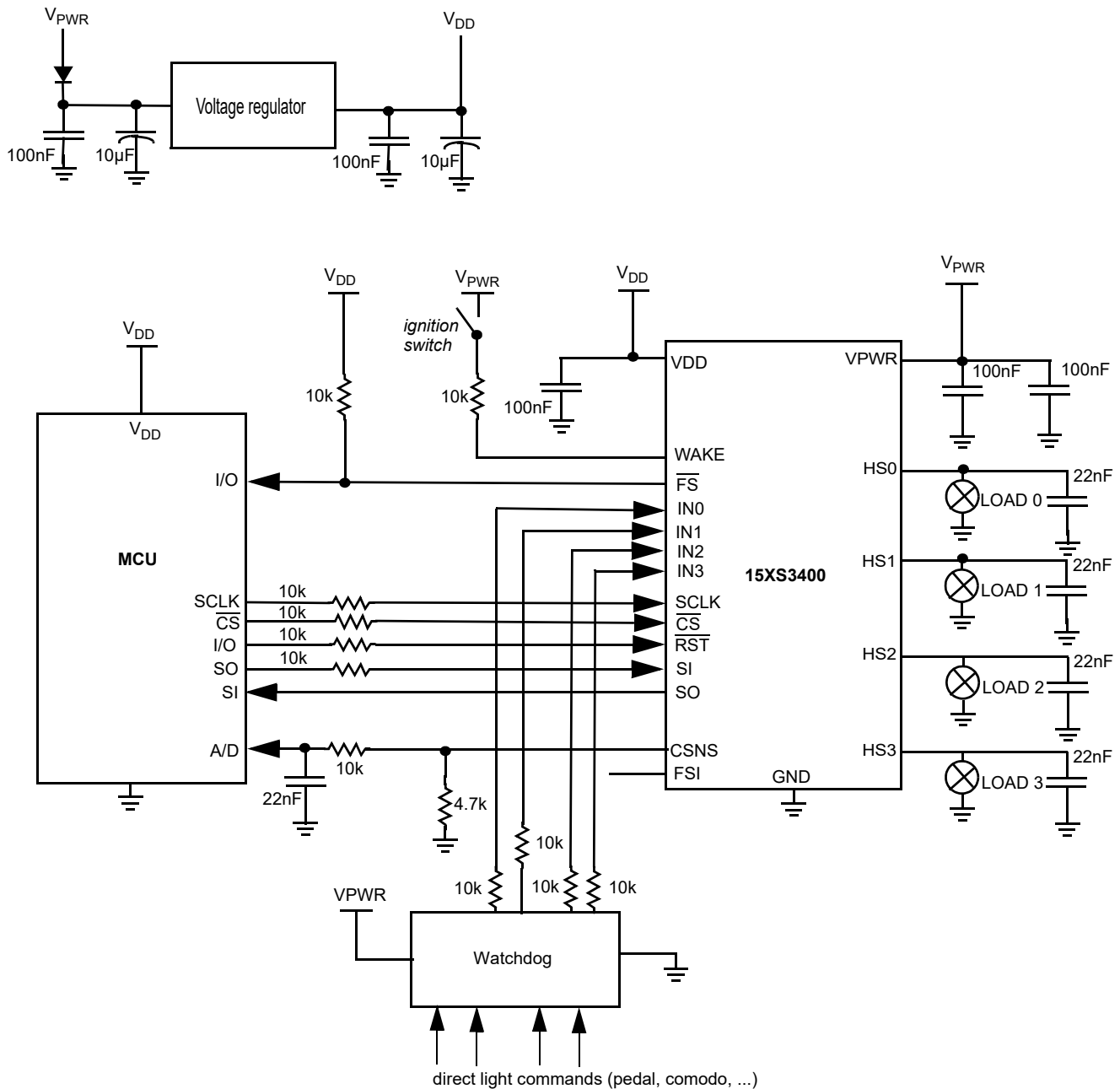

Figure 19. Typical application schematic

# 9 Packaging

## 9.1 Soldering information

The 15XS3400 is packaged in a surface mount power package intended to be soldered directly on the printed circuit board.

The AN2467 application note provides guidelines for printed circuit board design and assembly.

## 9.2 Package dimensions

For the most current package revision, visit [www.nxp.com](http://www.nxp.com) and perform a keyword search using the 98ARL10596D listed below. Dimensions shown are provided for reference ONLY.

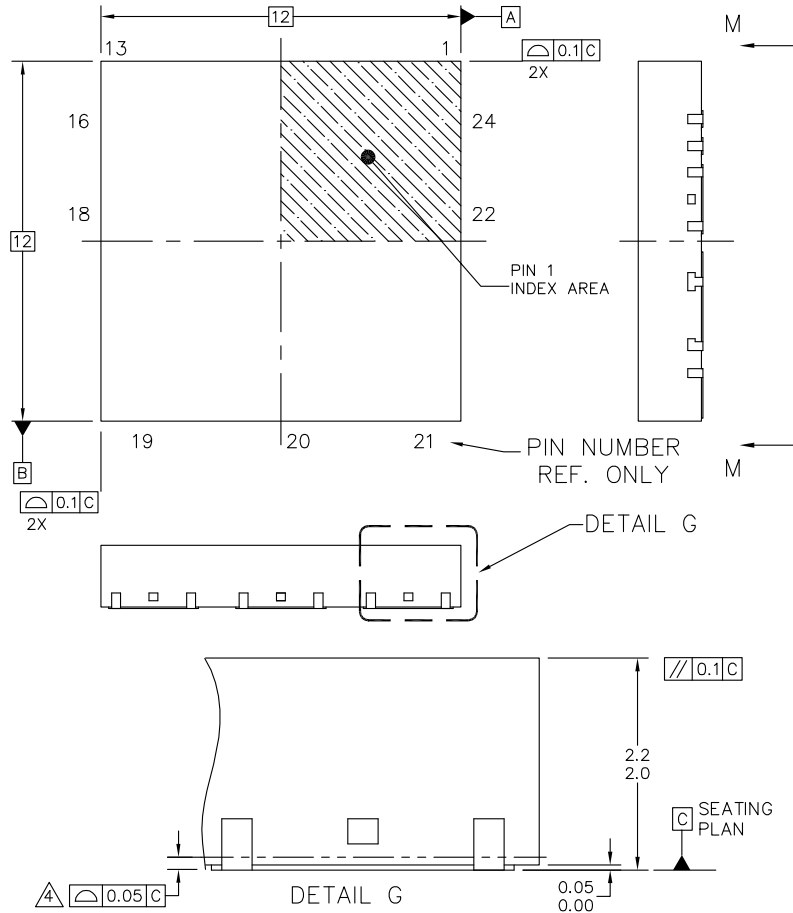

© FREESCALE SEMICONDUCTOR, INC. ALL RIGHTS RESERVED.	<b>MECHANICAL OUTLINE</b>	PRINT VERSION NOT TO SCALE	
TITLE: POWER QUAD FLAT NON-LEADED PACKAGE (PWR QFN) 24 TERMINAL, 0.9 PITCH(12X12X2.1)	DOCUMENT NO: 98ARL10596D	REV: D	
	CASE NUMBER: 1593-04	14 FEB 2008	
	STANDARD: NON-JEDEC		

**FK SUFFIX**  
24-PIN PQFN  
NONLEADED PACKAGE  
98ARL10596D  
ISSUE D

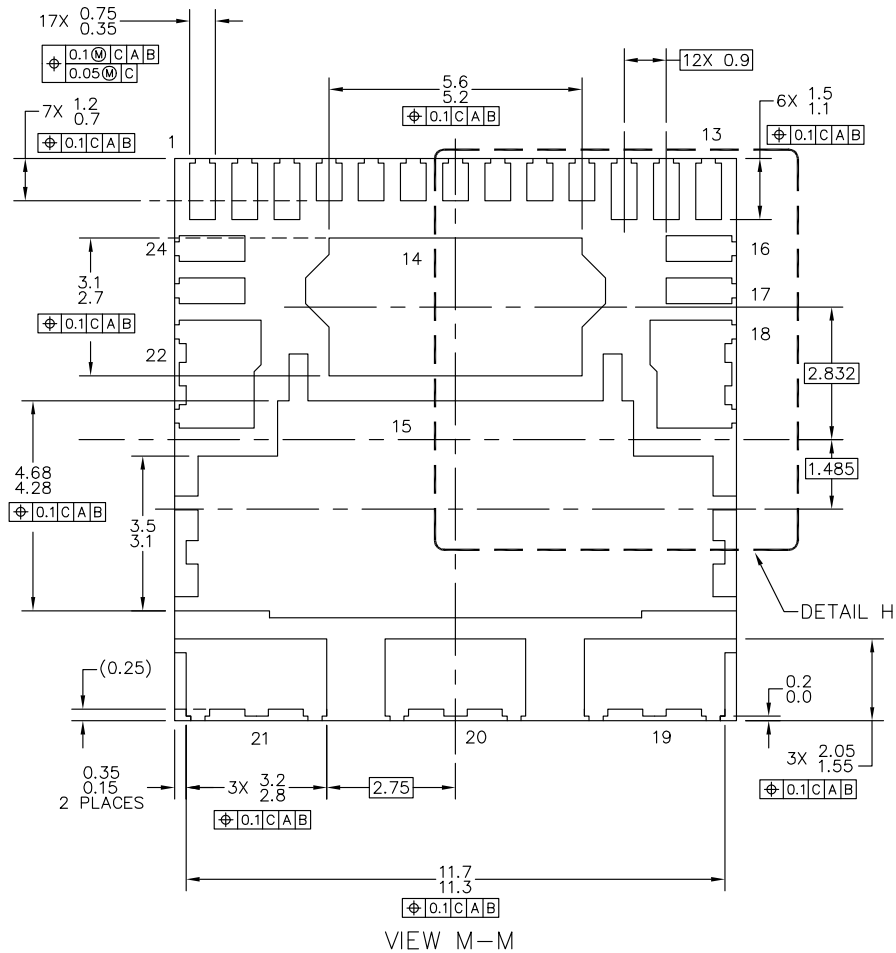

© FREESCALE SEMICONDUCTOR, INC. ALL RIGHTS RESERVED.	<b>MECHANICAL OUTLINE</b>	PRINT VERSION NOT TO SCALE	
TITLE: POWER QUAD FLAT NON-LEADED PACKAGE (PWR QFN) 24 TERMINAL, 0.9 PITCH(12X12X2.1)	DOCUMENT NO: 98ARL10596D CASE NUMBER: 1593-04 STANDARD: NON-JEDEC	REV: D 14 FEB 2008	

**FK SUFFIX**  
24-PIN PQFN  
NONLEADED PACKAGE  
98ARL10596D  
ISSUE D



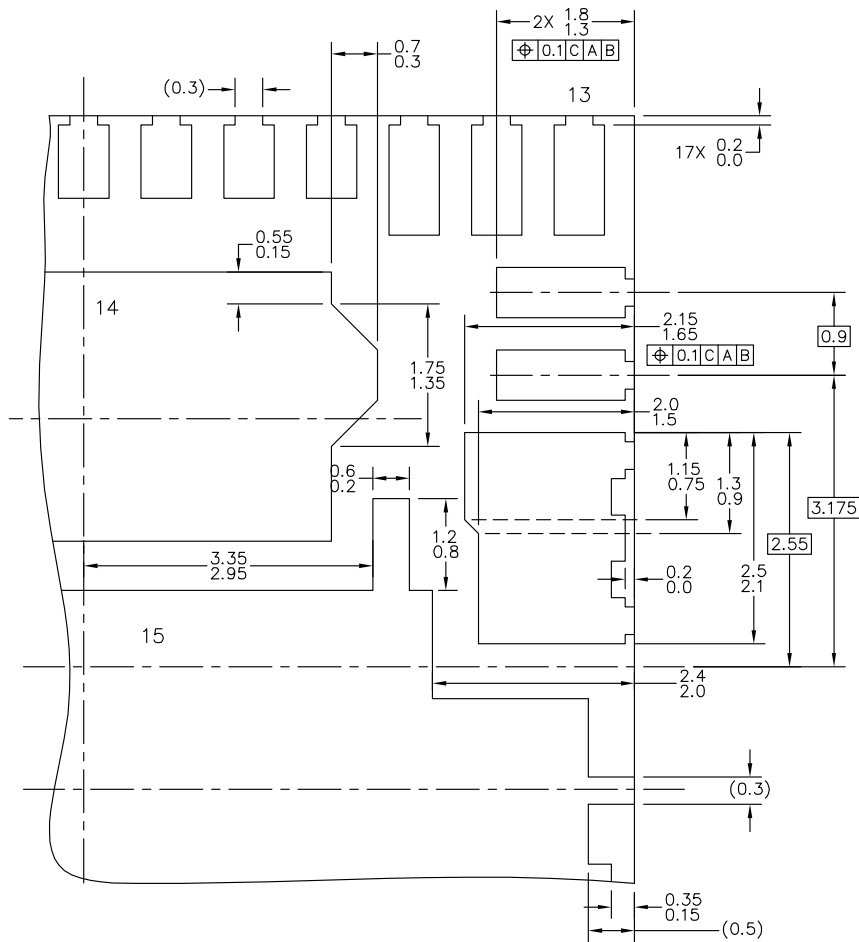

DETAIL H

© FREESCALE SEMICONDUCTOR, INC. ALL RIGHTS RESERVED.	<b>MECHANICAL OUTLINE</b>	PRINT VERSION NOT TO SCALE	
TITLE: POWER QUAD FLAT NON-LEADED PACKAGE (PWR QFN) 24 TERMINAL, 0.9 PITCH(12X12X2.1)	DOCUMENT NO: 98ARL10596D	REV: D	
	CASE NUMBER: 1593-04	14 FEB 2008	
STANDARD: NON-JEDEC			

**FK SUFFIX**  
24-PIN PQFN  
NONLEADED PACKAGE  
98ARL10596D  
ISSUE D

NOTES:

1. ALL DIMENSIONS ARE IN MILLIMETERS.
2. DIMENSIONING AND TOLERANCING PER ASME Y14.5M-1994.
3. THE COMPLETE JEDEC DESIGNATOR FOR THIS PACKAGE IS: HF-PQFP-N.
4.  COPLANARITY APPLIES TO LEADS AND CORNER LEADS.
5. MINIMUM METAL GAP IS GUARANTEED TO BE 0.25MM.

© FREESCALE SEMICONDUCTOR, INC. ALL RIGHTS RESERVED.	<b>MECHANICAL OUTLINE</b>	PRINT VERSION NOT TO SCALE	
TITLE: POWER QUAD FLAT NON-LEADED PACKAGE (PWR QFN) 24 TERMINAL, 0.9 PITCH(12X12X2.1)	DOCUMENT NO: 98ARL10596D	REV: D	
	CASE NUMBER: 1593-04	14 FEB 2008	
	STANDARD: NON-JEDEC		

**FK SUFFIX**  
 24-PIN PQFN  
 NONLEADED PACKAGE  
 98ARL10596D  
 ISSUE D

# 10 Additional documentation

## 10.1 Thermal addendum (Rev 2.0)

### 10.1.1 Introduction

This thermal addendum is provided as a supplement to the 15XS3400 technical data sheet. The addendum provides thermal performance information that may be critical in the design and development of system applications. All electrical, application and packaging information is provided in the data sheet.

### 10.1.2 Package and thermal considerations

This 15XS3400 is a dual die package. There are two heat sources in the package independently heating with  $P_1$  and  $P_2$ . This results in two junction temperatures,  $T_{J1}$  and  $T_{J2}$ , and a thermal resistance matrix with  $R_{\theta JA mn}$ .

For  $m, n = 1$ ,  $R_{\theta JA11}$  is the thermal resistance from Junction 1 to the reference temperature while only heat source 1 is heating with  $P_1$ .

For  $m = 1, n = 2$ ,  $R_{\theta JA12}$  is the thermal resistance from Junction 1 to the reference temperature while heat source 2 is heating with  $P_2$ . This applies to  $R_{\theta J21}$  and  $R_{\theta J22}$ , respectively.

$$\begin{Bmatrix} T_{J1} \\ T_{J2} \end{Bmatrix} = \begin{bmatrix} R_{\theta JA11} & R_{\theta JA12} \\ R_{\theta JA21} & R_{\theta JA22} \end{bmatrix} \cdot \begin{Bmatrix} P_1 \\ P_2 \end{Bmatrix}$$

The stated values are solely for a thermal performance comparison of one package to another in a standardized environment. This methodology is not meant to and will not predict the performance of a package in an application-specific environment. Stated values were obtained by measurement and simulation according to the standards listed below.

### 10.1.3 Standards

Table 26. Thermal performance comparison

Thermal Resistance	1 = Power Chip, 2 = Logic Chip [°C/W]		
	$m = 1, n = 1$	$m = 1, n = 2$ $m = 2, n = 1$	$m = 2, n = 2$
$R_{\theta JA mn}$ (1)(2)	26.10	18.31	35.38
$R_{\theta JB mn}$ (2)(3)	13.32	6.54	23.46
$R_{\theta JA mn}$ (1)(4)	46.55	37.07	53.82
$R_{\theta J C mn}$ (5)	0.75	0.00	0.91

Notes:

1. Per JEDEC JESD51-2 at natural convection, still air condition.
2. 2s2p thermal test board per JEDEC JESD51-7 and JESD51-5.
3. Per JEDEC JESD51-8, with the board temperature on the center trace near the power outputs.
4. Single layer thermal test board per JEDEC JESD51-3 and JESD51-5.
5. Thermal resistance between the die junction and the exposed pad, "infinite" heat sink attached to exposed pad.

15XS3400

24-PIN  
PQFN

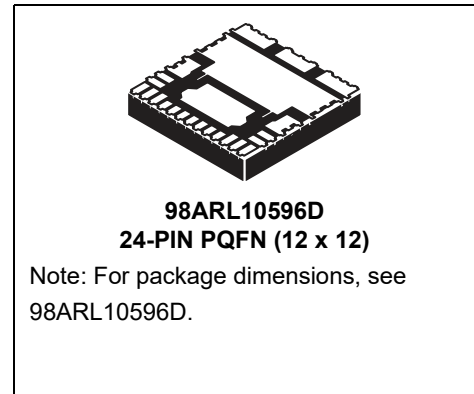

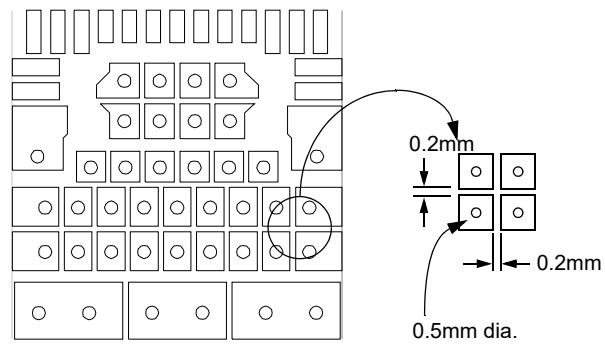

Figure 20. Detail of copper traces under device with thermal vias

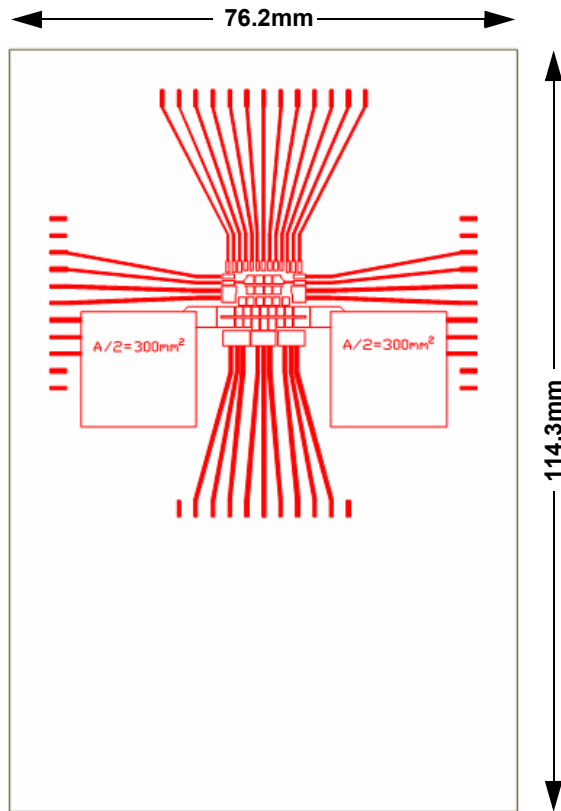
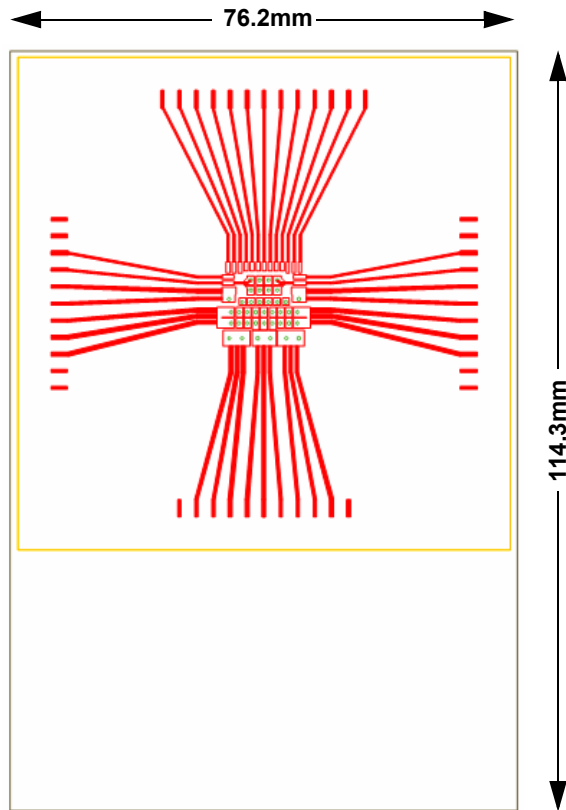
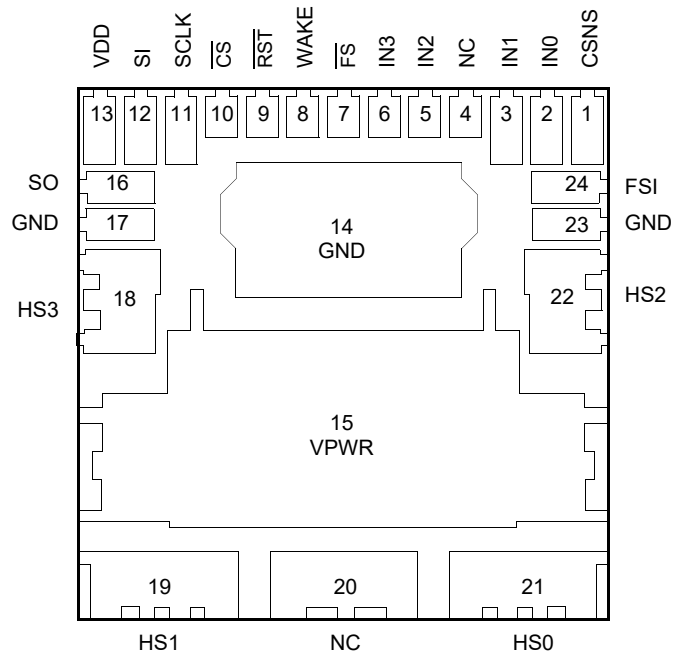

Figure 21. 1s JEDEC thermal test board layout



**Figure 22. 2s2p JDEC thermal test board  
(Red - top layer, Yellow - two buried layers)**

Transparent Top View



MC10XS3435 Pin Connections  
24-PIN PQFN (12 x 12)  
0.9 mm Pitch  
12.0mm 12.0mm Body

**Figure 23. Pin connections**

## 10.1.4 Device on thermal test board

Material:	Single layer printed circuit board FR4, 1.6 mm thickness Cu traces, 0.07 mm thickness Cu buried traces thickness 0.035 mm
Outline:	76.2 mm x 114.3 mm board area, including edge connector for thermal testing, 74 mm x 74 mm buried layers area
Area A:	Cu heat-spreading areas on board surface
Ambient Conditions:	Natural convection, still air

**Table 27. Thermal resistance performance**

Thermal Resistance	Area A (mm <sup>2</sup> )	1 = Power Chip, 2 = Logic Chip (°C/W)		
		<i>m</i> = 1, <i>n</i> = 1	<i>m</i> = 1, <i>n</i> = 2 <i>m</i> = 2, <i>n</i> = 1	<i>m</i> = 2, <i>n</i> = 2
$R_{\theta JA mn}$	0	46.55	37.10	53.82
	150	41.64	33.07	50.74
	300	40.22	32.01	49.89
	450	38.88	30.64	48.99
	600	38.32	30.49	48.18

$R_{\theta JA}$  is the thermal resistance between die junction and ambient air.

This device is a dual die package. Index *m* indicates the die that is heated. Index *n* refers to the number of the die where the junction temperature is sensed.

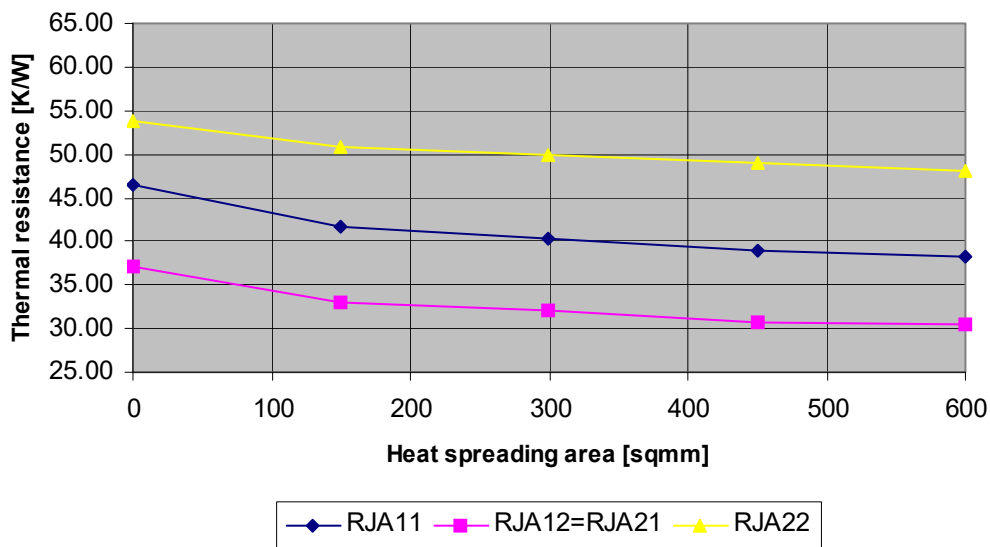

**Figure 24. Steady state thermal resistance in dependance on heat spreading area; 1s JEDEC thermal test board with spreading areas**

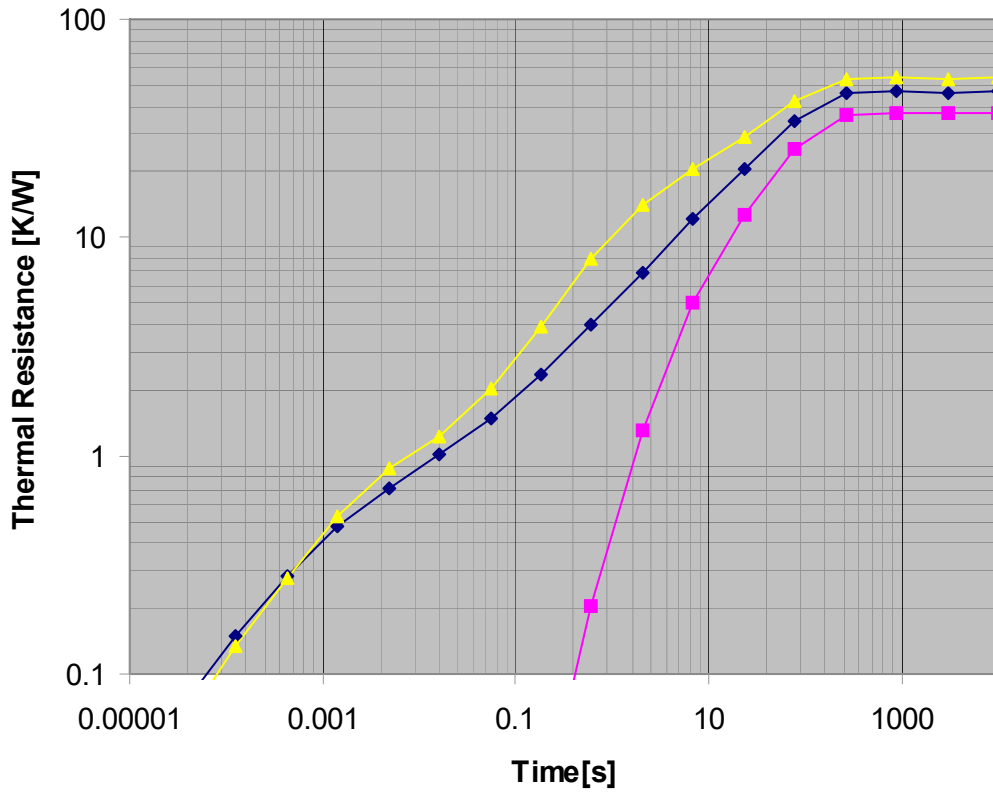

Figure 25. Transient thermal 1W step response; device on 1s JEDEC standard thermal test board with heat spreading areas 600 Sq. mm

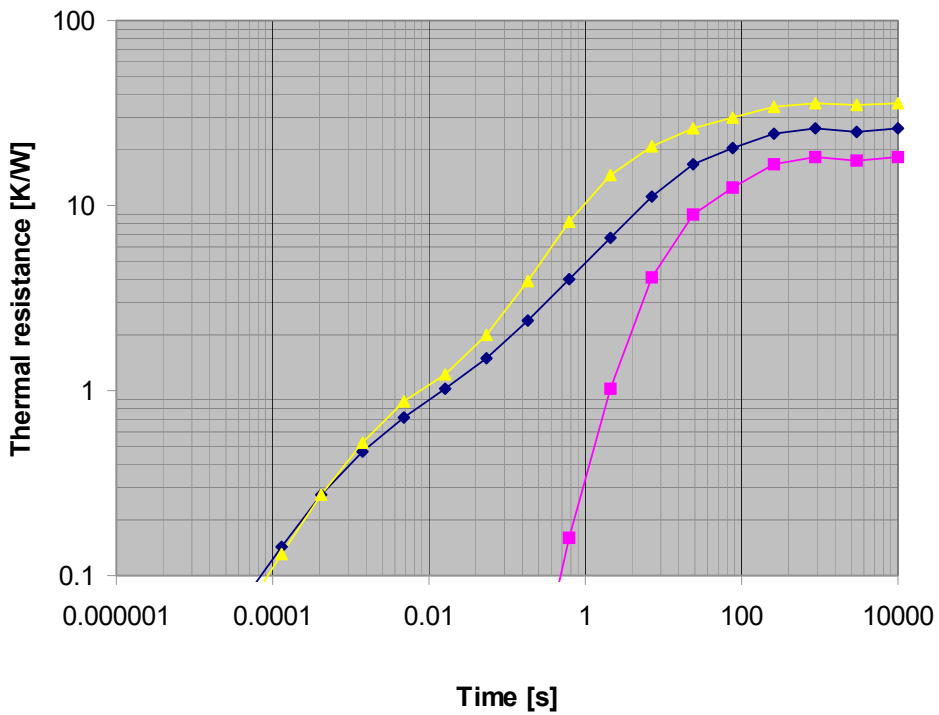

Figure 26. Transient thermal 1W step response; device on 2s2p JEDEC standard thermal test board

# 11 Revision history

Revision	Date	Description of changes
5.0	9/2008	<ul style="list-style-type: none"> <li>Initial release</li> </ul>
6.0	10/2008	<ul style="list-style-type: none"> <li>Changed Maximum rating for <i>Output Source-to-Drain ON Resistance</i> in Static Electrical Characteristics Table on page 8.</li> <li>Added explanation for recovering to Sleep Mode on page 26.</li> <li>Updated Outline Drawing to new Revision.</li> </ul>
7.0	12/2008	<ul style="list-style-type: none"> <li>Changed Orderable Part Number from PC15XS3400CPNA to MC15XS3400CPNA on page 1.</li> <li>Removed Pb-Free throughout document. This device is not Pb-free.</li> <li>Changed <math>V_{\text{supply(POR)}}</math>, Max limit from 0.8 to 0.9 and VDD(FAIL), from Min = 0.5, Typ = -, Max = 0.8 to Min = 2.2, Typ = 2.5 and Max = 2.8 on Page 7.</li> </ul>
8.0	7/2009	<ul style="list-style-type: none"> <li>Added MC15XS3400DPNA part number. The "D" version has different soldering limits.</li> </ul>
9.0	10/2009	<ul style="list-style-type: none"> <li>Corrected minor formatting</li> <li>Separated definitions for the 15XS3400C and 15XS3400D in the Static and Dynamic Tables</li> </ul>
10.0	05/2012	<ul style="list-style-type: none"> <li>Changed orderable part number MC15XS3400CPNA to MC15XS3400CHFK and MC15XS3400DPNA to MC15XS3400DHFK</li> <li>Updated the pin soldering temperature limit from 10 seconds to 40 seconds (Note <sup>(2)</sup> and <sup>(9)</sup>).</li> <li>Updated Freescale form and style</li> </ul>
11.0	8/2018	<ul style="list-style-type: none"> <li>Updated as per CIN 201808007I               <ul style="list-style-type: none"> <li>Corrected <math>T_{\text{OLLED}}</math> values in <a href="#">Table 6. Dynamic electrical characteristics</a></li> <li>Updated <a href="#">Openload detection in ON state for LED</a> (added clarification for the usage of openload LED function and changed D[6:0]=7F to D[7:0]=FF)</li> </ul> </li> </ul>





**How to Reach Us:**

**Home Page:**

[NXP.com](http://www.nxp.com)

**Web Support:**

<http://www.nxp.com/support>

Information in this document is provided solely to enable system and software implementers to use NXP products. There are no expressed or implied copyright licenses granted hereunder to design or fabricate any integrated circuits based on the information in this document. NXP reserves the right to make changes without further notice to any products herein.

NXP makes no warranty, representation, or guarantee regarding the suitability of its products for any particular purpose, nor does NXP assume any liability arising out of the application or use of any product or circuit, and specifically disclaims any and all liability, including without limitation, consequential or incidental damages. "Typical" parameters that may be provided in NXP data sheets and/or specifications can and do vary in different applications, and actual performance may vary over time. All operating parameters, including "typicals," must be validated for each customer application by the customer's technical experts. NXP does not convey any license under its patent rights nor the rights of others. NXP sells products pursuant to standard terms and conditions of sale, which can be found at the following address:

<http://www.nxp.com/terms-of-use.html>.

NXP, the NXP logo, Freescale, the Freescale logo and SMARTMOS are trademarks of NXP B.V. All other product or service names are the property of their respective owners. All rights reserved.

© 2018 NXP B.V.

Document Number: MC15XS3400

Rev. 11.0

8/2018

