

THIS DRAWING IS UNPUBLISHED. RELEASED FOR PUBLICATION
 © COPYRIGHT BY TYCO ELECTRONICS CORPORATION. ALL RIGHTS RESERVED.

LOC	DIST	REVISIONS			
P	LTR	DESCRIPTION	DATE	DWN	APVD
AF	50	A1	REVISED PER ECR-07-019908	24AUG07	HMR KR

IDENTIFICATION NUMBER 5 FOR MAGNET WIRE RANGE

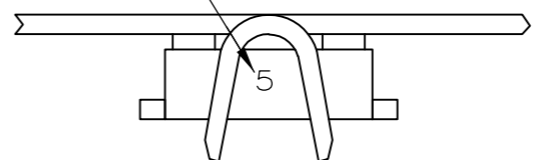

- 1 SLOT TERMINATES 0.23-0.32mm [#31-#28] AWG COPPER MAGNET WIRE EITHER SINGLE OR DOUBLE OF THE SAME SIZE.
- 2 CONTINUOUS STRIP ON REELS WITH TERMINALS LOCATED ON 8.38±0.08 [.330±.003] CENTERS.
- 3 WIRE BARREL TO ACCEPTS #24-#20 AWG STRANDED LEAD WIRE.

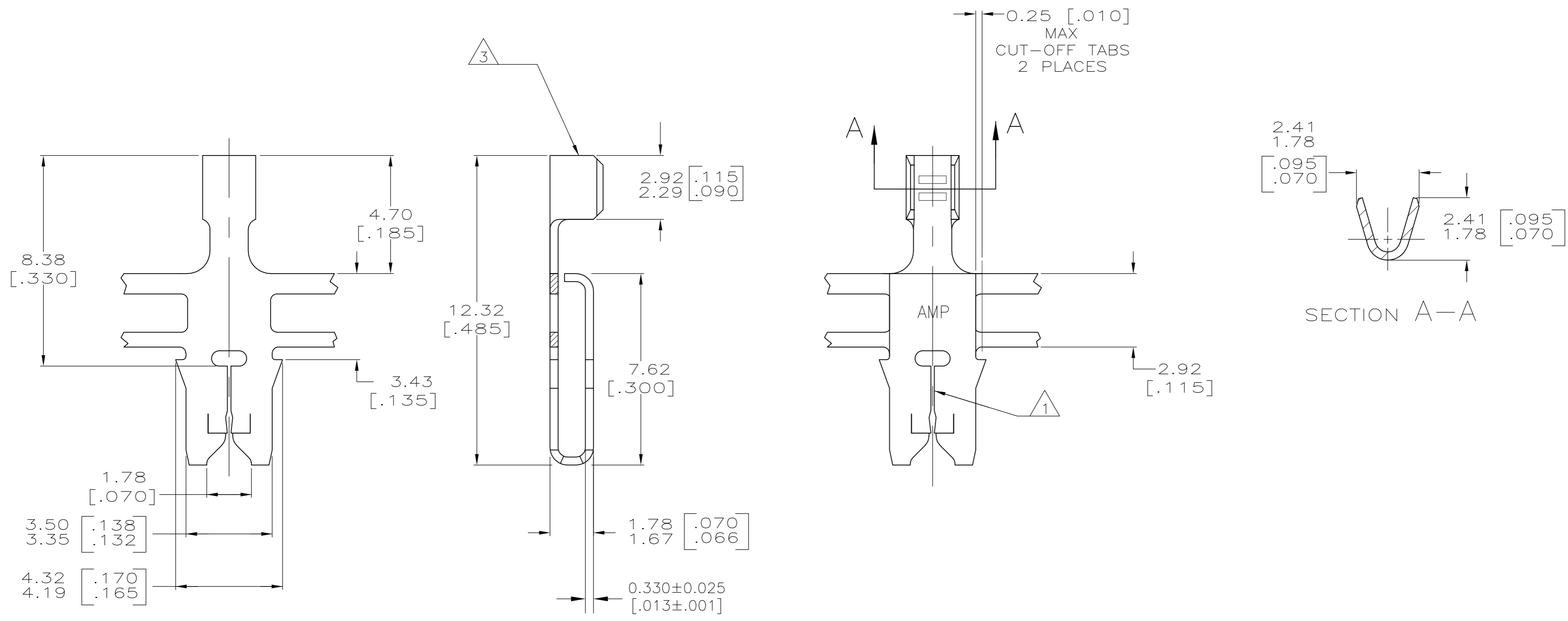

1742614-1
PART NUMBER

THIS DRAWING IS A CONTROLLED DOCUMENT.		DWN 09JUL2007 MICHAEL S. FEHER	Tyco Electronics Corporation Harrisburg, PA 17105-3608	
DIMENSIONS: INCHES		CHK 09JUL2007 KURT A. RANDOLPH	NAME KURT A. RANDOLPH	
TOLERANCES UNLESS OTHERWISE SPECIFIED:		APVD 09JUL2007 KURT A. RANDOLPH	PRODUCT SPEC 108-2012	
0 PLC ± -		APPLICATION SPEC 114-2046		
1 PLC ± -		SIZE A2		
2 PLC ± 0.25[.010]		CAGE CODE 00779		
3 PLC ± -		DRAWING NO 1742614		
4 PLC ± -		RESTRICTED TO -		
ANGLES ± -		SCALE 8:1		
FINISH 4M BRASS		SHEET 1 of 1		
0.002032[.000080] MIN TIN PLATE		REV A1		
CUSTOMER DRAWING				