



Part Number: D3C5814

Electrical Specifications

Frequency Range (GHz):	5.80 - 6.85 / 7.90 - 8.40 / 13.75 - 14.50
Isolation (dB):	15 MIN
Insertion Loss (dB):	0.8 MAX
VSWR:	1.3:1 MIN
Forward Power (W):	20 AVG 30 PK

Mechanical/Environmental Specifications

Connector Type:	SMA
Connector Body:	Passivated stainless steel
Connector Pin:	Gold plated copper
Load Body:	Brass
Magnetic Shunt:	Nickel plated CRS
Operational Temp:	-30°C to +65°C
Weight (oz)	1.0 MAX

D3C5814 Dimensions

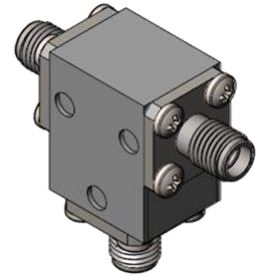
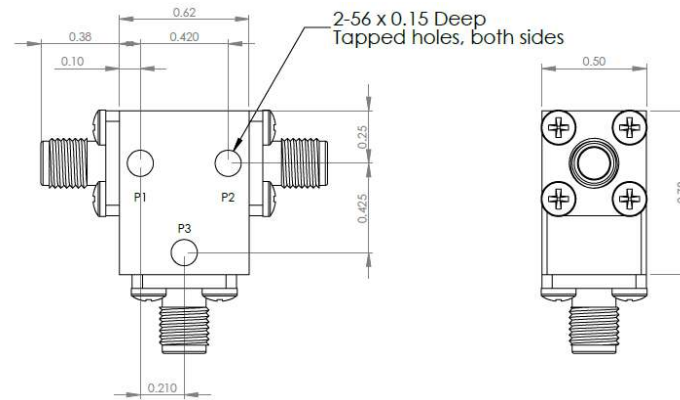

D3C5814-3 Dimensions

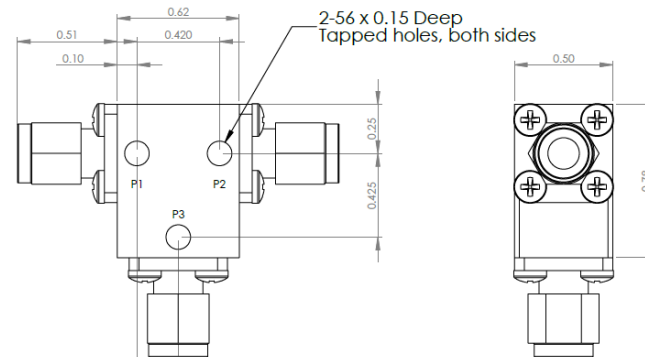

Dimensions are in inches
Tolerance

XX	±0.03
XXX	±0.010

Type of Device	PN Suffix	Connector Configuration Input / Output	PN Example
Single Junction Circulator 3-Port Device Port 1 / Port 2 / Port 3	No Dash	Female / Female / Female	D3C5814
	-1	Male / Female / Female	D3C5814-1
	-2	Female / Male / Female	D3C5814-2
	-3	Male / Male / Male	D3C5814-3
	-4	Female / Female / Male	D3C5814-4
	-5	Male / Female / Male	D3C5814-5
	-6	Male / Male / Female	D3C5814-6
-7	Female / Male / Male	D3C5814-7	



MEASURED DATA

Part Number: D3C5814, P1→P2, P3 Terminated with 50Ω, +25°C

