

UG390: Si834x-EVB User Guide

Description

The Si834x-IF provides up to four isolated high-side (sourcing) or low-side (sinking) switches with low R_{ON} . These switches are ideal for driving resistive and inductive loads such as solenoids, relays, and lamps commonly found in industrial control systems like PLCs. Each switch is galvanically isolated for safety using Skyworks Solutions' ground-breaking CMOS-based isolation technology which enables easy interfacing with low voltage 2.25 V MCUs and high CMTI (100 kV/ μ s).

The Si834x evaluation board allows designers to evaluate Skyworks' Si834x family of Isolated Smart Switches. Each board comes populated with one Si834x device, LED status indicators, pluggable load terminals for evaluation of the device's key parameters, and test points for monitoring device pins. Additional information on the Si834x products can be found at <https://www.skyworksinc.com/Products/Isolation>. The product data sheet and application notes can be referenced to help facilitate designs.

Key Features

Si834x-based evaluation boards are populated with one of the following parts:

- Si83404AAA
- Si83414AAA
- Si83402BAA
- Si83412BAA
- Si83411BAA
- Si83401BAA

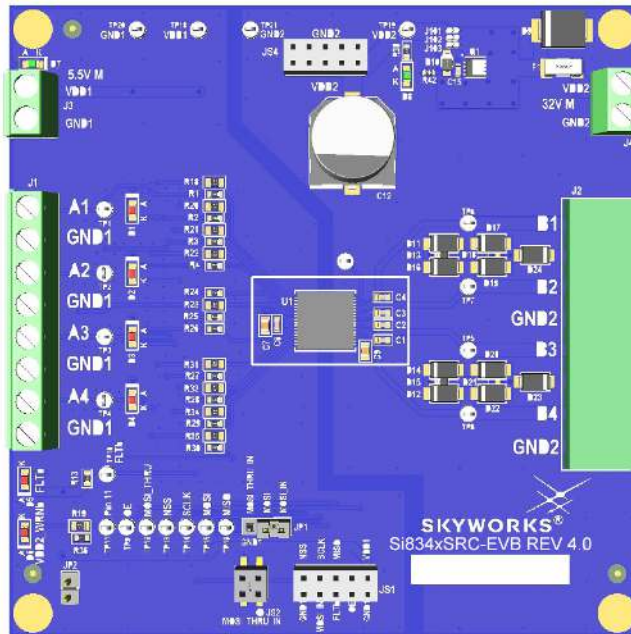

1. Ordering Guide

Table 1. Si834x Evaluation Board Ordering Guide

Ordering Part Number (OPN)	Description
Si83404AAA-KIT	Si83404AAA Isolated Smart Switch Evaluation Kit
Si83414AAA-KIT	Si83414AAA Isolated Smart Switch Evaluation Kit
Si83402BAA-KIT	Si83402BAA Isolated Smart Switch Evaluation Kit
Si83412BAA-KIT	Si83412BAA Isolated Smart Switch Evaluation Kit
Si83401BAA-KIT	Si83401BAA Isolated Smart Switch Evaluation Kit
Si83411BAA-KIT	Si83411BAA Isolated Smart Switch Evaluation Kit

2. Test Procedure

The procedure below assumes you are familiar with the Si834x device. If not, see “3. Using the Evaluation Board” on page 7 for key background information. Throughout this document, “sourcing” (or SRC) refers to Si8340x part numbers and their corresponding sourcing PCBs, and “sinking” (or SNK) refers to Si8341x part numbers and their corresponding sinking EVBs.

The following equipment is required to demonstrate the evaluation board features:

- Function generator
- One dual-channel dc power supply or two single supplies: 0–5 V and 0–24 V
- One oscilloscope with at least two channels
- Up to four k Ω through-hole resistors (1 minimum)
- Si834x-EVB kit
 - Si834x-EVB User’s Guide (this document)
- Assorted cables, leads, and probes as necessary to connect equipment to EVB

2.1. DC Supply Configuration

2.1.1. VDD1 Supply Configuration

1. Set one supply to output 5 VDC.
2. Turn OFF the supply and connect the positive lead to VDD1 (J3-1 or TP18).
3. Connect the negative lead to GND1 (J3-2 or TP20).
4. Turn ON the supply.
5. Ensure that LED D7 turns on and that LED D5 is blinking (this indicates there is no VDD2 supply).
6. Ensure that the current draw is less than 25 mA. If it is larger, this indicates that either the board or Si834x has been damaged or that the supply is connected backwards.

2.1.2. VDD2 Supply Configuration

1. Set the second supply to output 0 VDC.
2. Turn OFF the supply and connect the positive lead to VDD2 (J4-1 or TP19).
3. Connect the negative lead to GND2 (J4-2 or TP21).
4. Turn ON the supply.
5. Slowly ramp the voltage from 0 VDC to 24 VDC.
6. Ensure that LED D8 turns on and that LED D5 turns off.
7. Ensure that the current draw is less than 25 mA. If it is larger, this indicates that either the board or the Si834x has been damaged or that the supply is connected backwards.

2.2. Input Configuration Procedure

1. Turn ON the function generator with the output disabled. If you do not have a waveform generator, or prefer not to use one, you may simply apply 5 V to the input channels on the Si834x to observe the output channel coming on. The proper configuration is shown in the figures below.
2. Adjust the output to provide a 100 Hz, 0 to 5 V peak square wave with 50% duty cycle.
3. Connect the positive lead of the generator to A1 (J1-1 or TP1) and ground the connection to GND1 (J1, J3, or TP20).
4. If possible, configure the function generator for a High-Z (high-impedance) load.

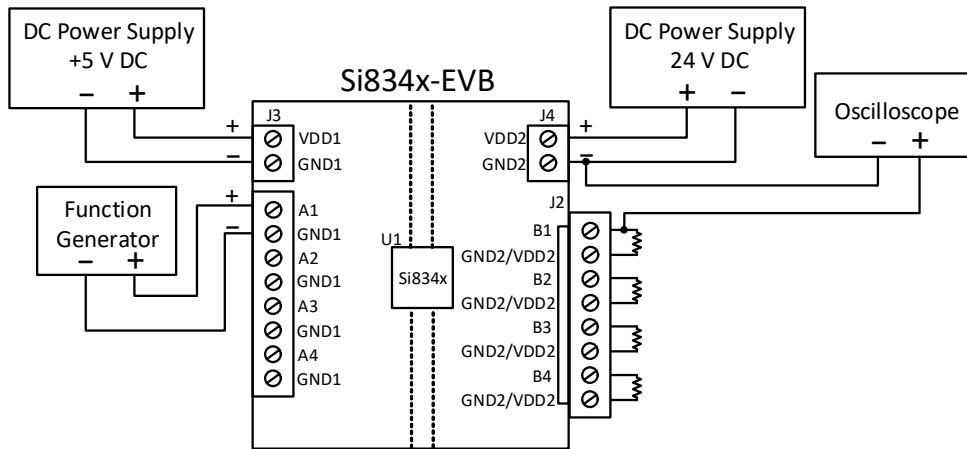

Figure 1. Si834x4-EVB Configuration

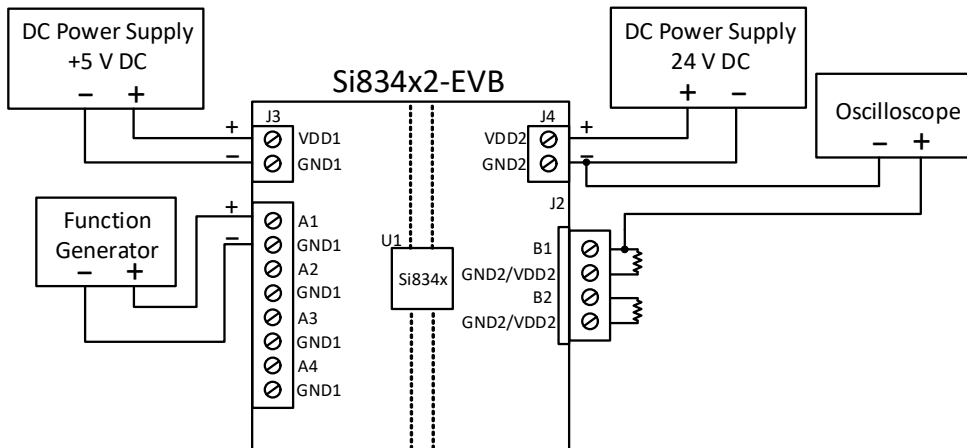

Figure 2. Si834x2-EVB Configuration

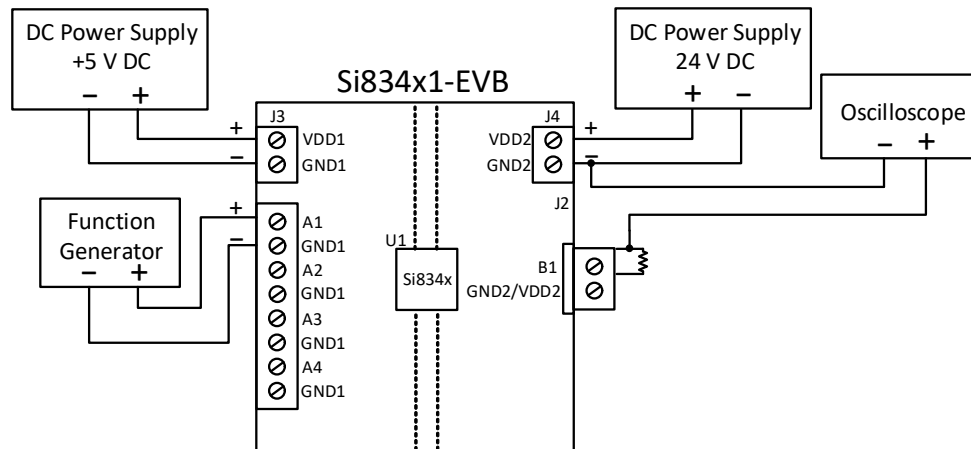

Figure 3. Si834x1-EVB Configuration

2.3. Load Configuration

1. Turn OFF the 24 VDC power supply.
2. Connect a 10 k Ω resistor to channel B1 by placing one lead in the first slot of the terminal block (J2) and screwing it down. Place the other lead in the second slot (J2) and screw it down. This connection is the same for both SRC and SNK EVBs.
3. Populate all remaining channels (B2, B3, and B4 if possible) with the remaining resistors.
4. Turn ON the 24 V supply.

2.4. Oscilloscope Setup

1. Connect the CH1 probe to A1 (TP1) and ground the probe to GND1 (TP20).
2. Connect the CH2 probe to B1 (TP6) and ground the probe to GND2 (TP21).
3. Set the scope to Trigger on a rising edge on CH1 and adjust the trigger level to approximately 2 V.
4. Set CH1 to 2 V per division and CH2 to 10 V per division.
5. Adjust the horizontal zoom to 500 μ s per division.

2.5. Activate Channels

1. Enable the function generator output on Channel A1 or apply 5 V directly.
2. Ensure that D1 turns on.
3. Adjust the vertical and horizontal divisions to properly view the waveform as seen in the image below.

A 100 Hz square wave with 50% duty cycle should appear on Channel 1, and a similar waveform with peak voltage of 24 V should appear on Channel 2. Note that the output waveform in the figure below is for a sourcing device, and the polarity will be opposite for sinking devices.



Figure 4. Oscilloscope Waveform with 100 Hz Square Wave Input

2.6. Repeat for Remaining Channels (if Applicable)

1. Disable the function generator output.
2. Connect the CH1 probe to A2 (TP2).
3. Connect the CH2 probe to B2 (TP7).
4. Connect the positive lead of the function generator to A2 (TP2).
5. Enable the function generator.
6. Ensure that LED D2 turns on.
7. For Si834x4AAA EVBs, repeat steps 1–5 with channels A3 and A4 using test point TP3 for A3, TP5 for B3, TP4 for A4, and TP8 for B4.

3. Using the Evaluation Board

The Si834x-EVB comes populated with one of six different Si834x devices that may require different input types and load configurations. This section explains those differences as well as how to configure your setup to properly utilize the evaluation board.

Table 2. Si834x Input and Output Configurations

Part Number	Input Interface	Switch Type	Load Terminals	PCB
Si83404AAA	Parallel	High-Side (SRC)	Bn and GND2	Si834xSRC-EVB Rev 4.0
Si83414AAA	Parallel	Low-Side (SNK)	Bn and VDD2	Si834xSNK-EVB Rev 4.0
Si83402BAA	Parallel	High-Side (SRC)	Bn and GND2	Si83402SRC-EVB Rev 2.0
Si83412BAA	Parallel	Low-Side (SNK)	Bn and VDD2	Si83412SNK-EVB Rev 2.0
Si83401BAA	Parallel	High-Side (SRC)	Bn and GND2	Si83401SRC-EVB Rev 2.0
Si83411BAA	Parallel	Low Side (SNK)	Bn and VDD2	Si83411SNK-EVB Rev 2.0

3.1. Load Termination

Sourcing parts utilize high side switches that require the load to be connected from the channel output (Bn) to GND2. Sinking parts contain a low side switch that require the load to instead be connected from output (Bn) to VDD2. The output-side screw terminals (J2) on the sourcing EVBs contain connections to GND2, while the sinking EVBs contain connections to VDD2. This allows J2 Pins 2, 4, 6, and 8 to be used for load termination on both the sourcing and sinking evaluation boards.

4. Evaluation Board Schematics

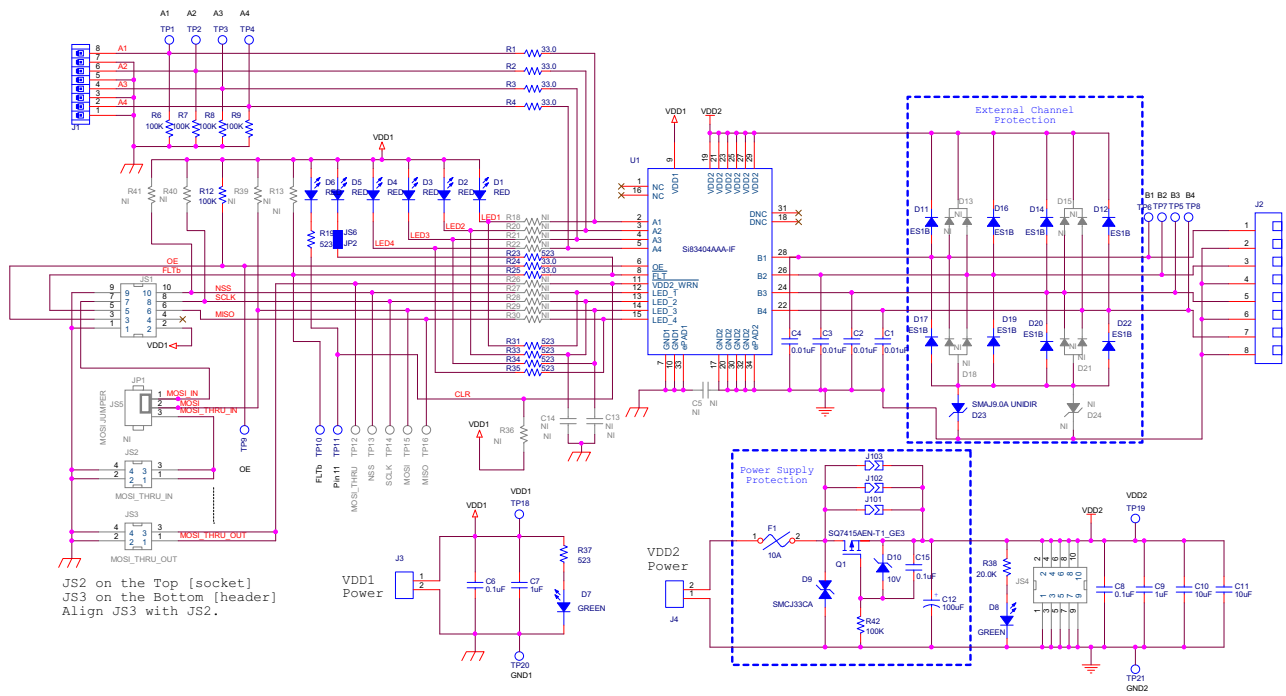

JS2 on the Top [socket]
JS3 on the Bottom [header]
Align JS3 with JS2.

Figure 5. Si83404AAA Rev 4.0 Schematic Diagram

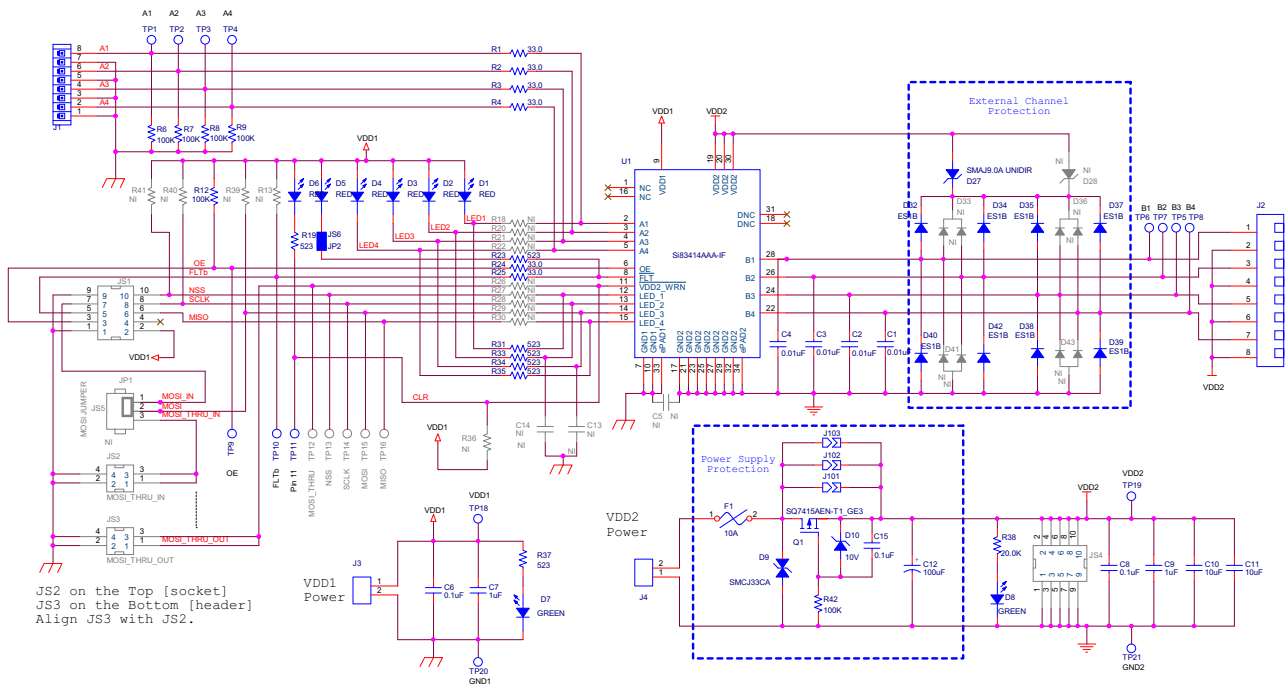

JS2 on the Top [socket]
JS3 on the Bottom [header]
Align JS3 with JS2.

Figure 6. Si83414AAA Rev 4.0 Schematic Diagram

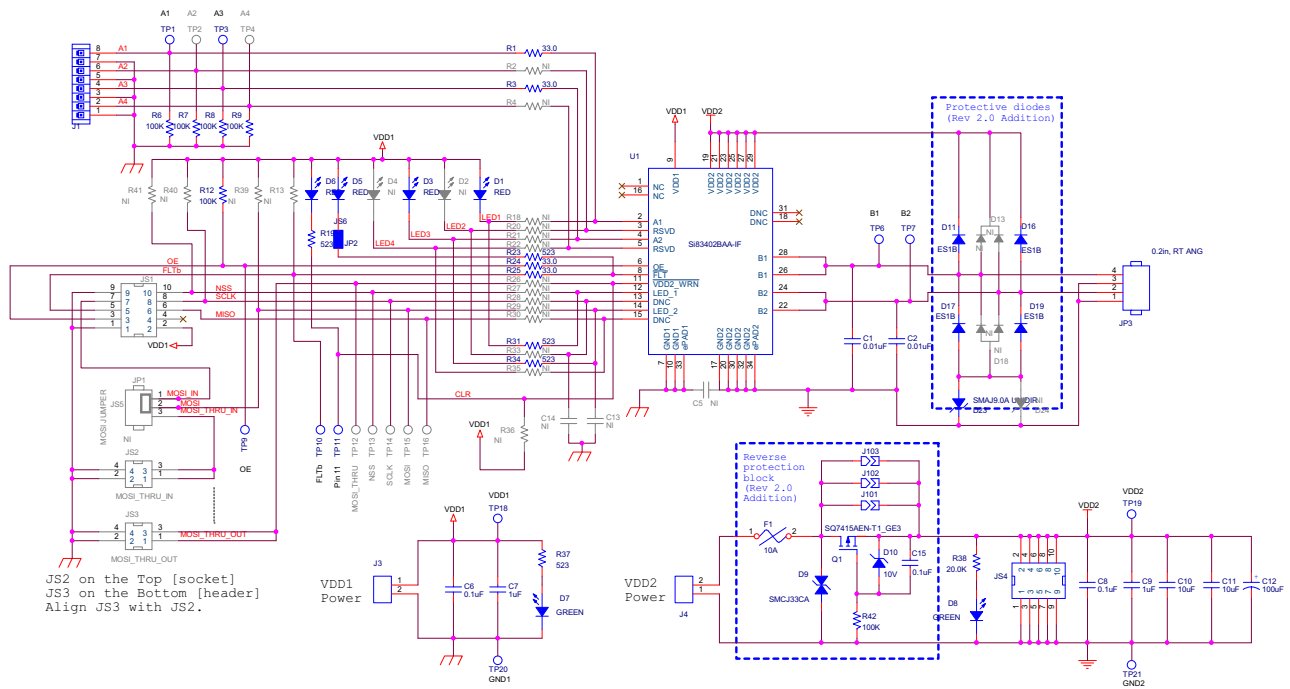

Figure 7. Si83402BAA Rev 2.0 Schematic Diagram

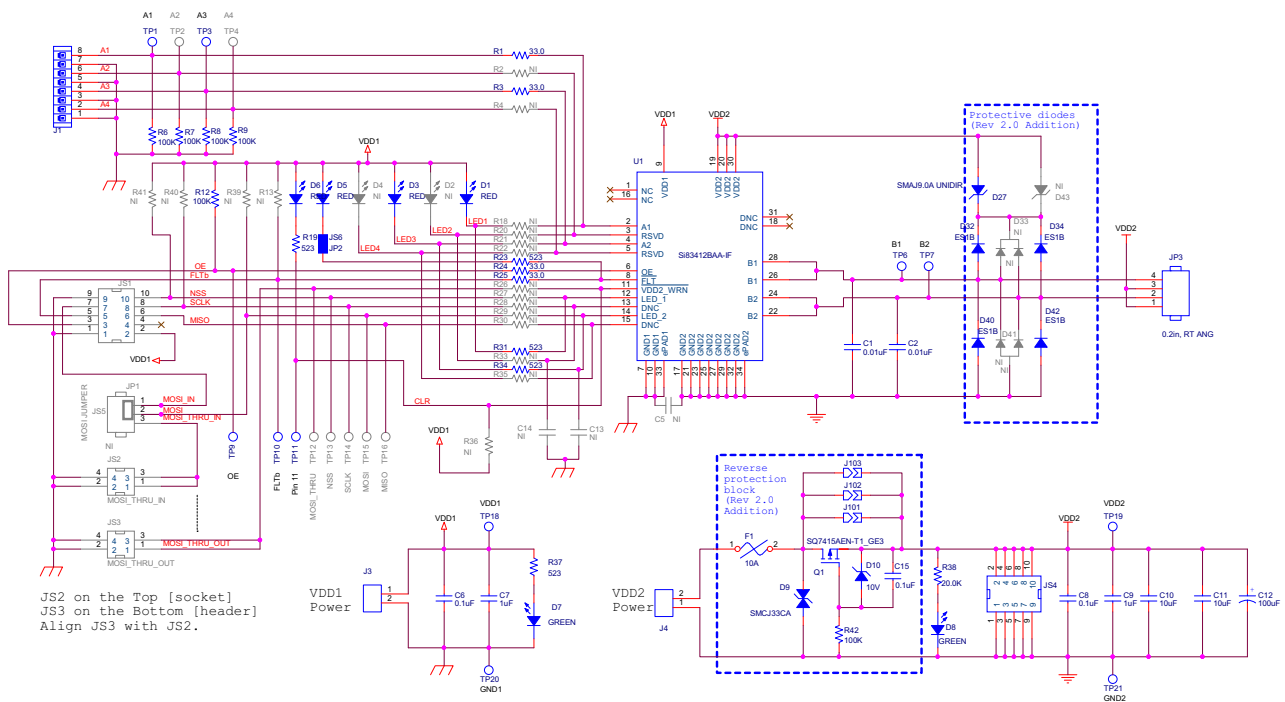

Figure 8. Si83412BAA Rev 2.0 Schematic Diagram

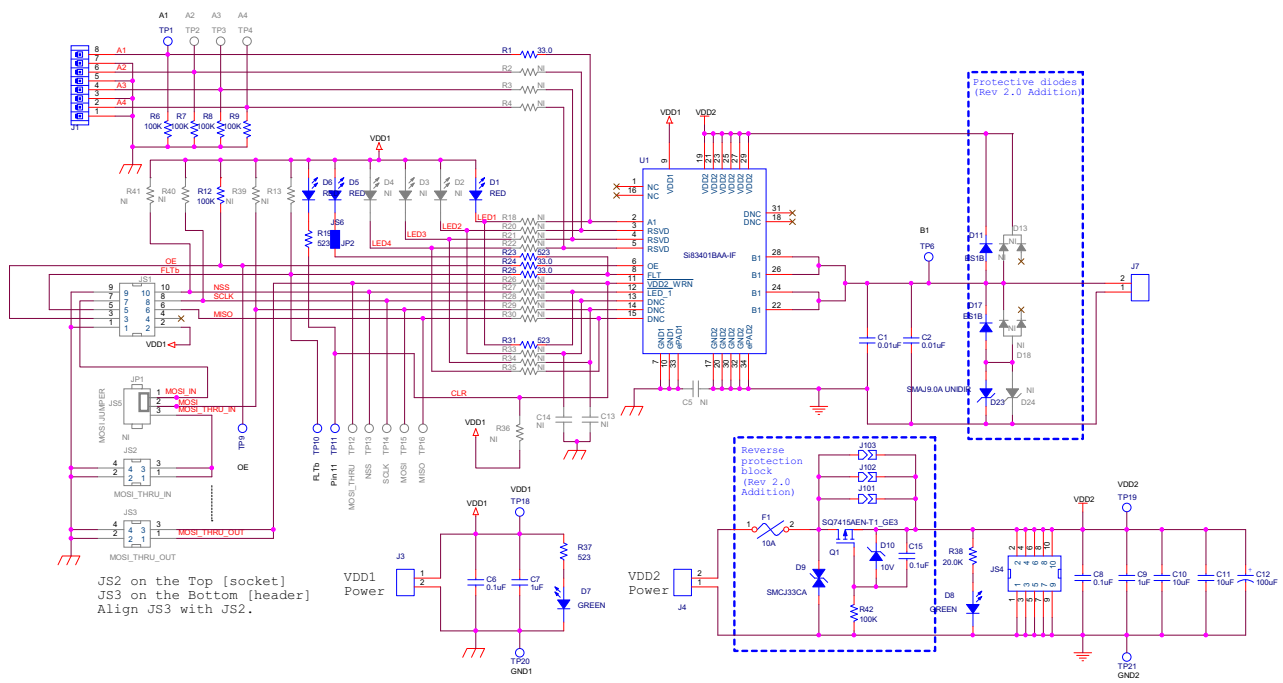

Figure 9. Si83401BAA Rev 2.0 Schematic Diagram

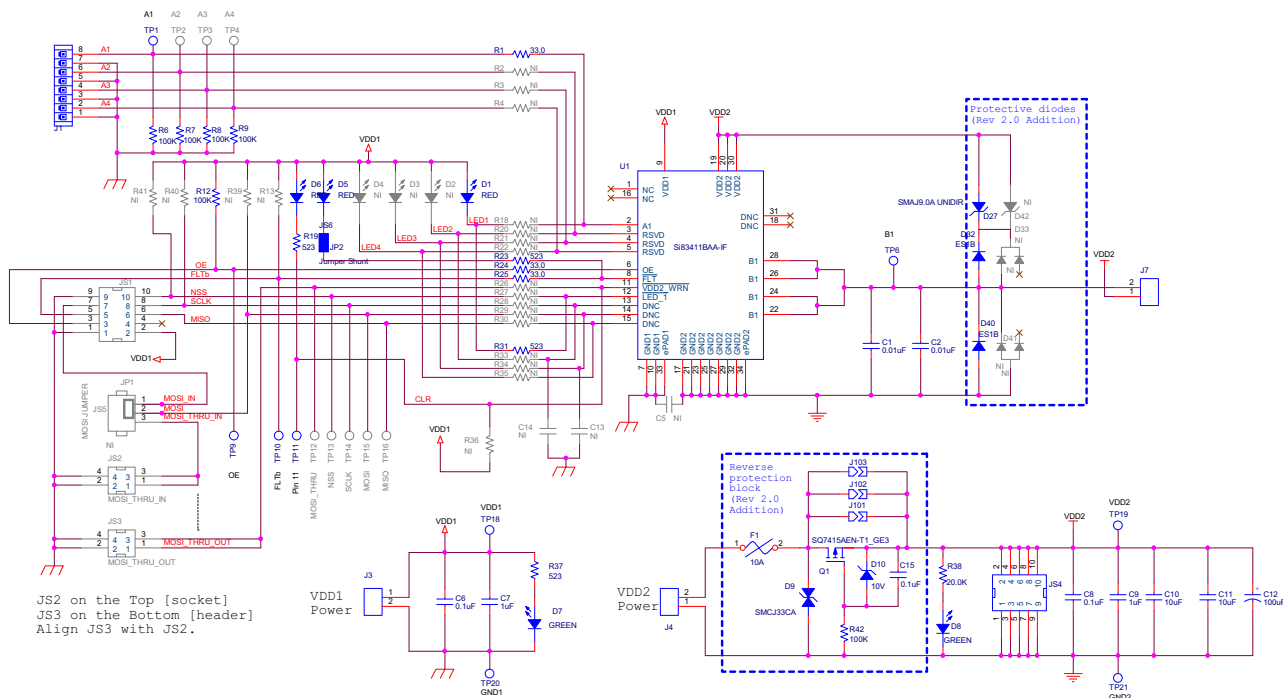

Figure 10. Si83411BAA Rev 2.0 Schematic Diagram

5. Evaluation Board Layouts

5.1. Si834xSRC-EVB Rev 4.0 Layouts

The Si834xSRC-EVB Rev 4.0 PCBs are used for the Si83414AAA-EVB only.

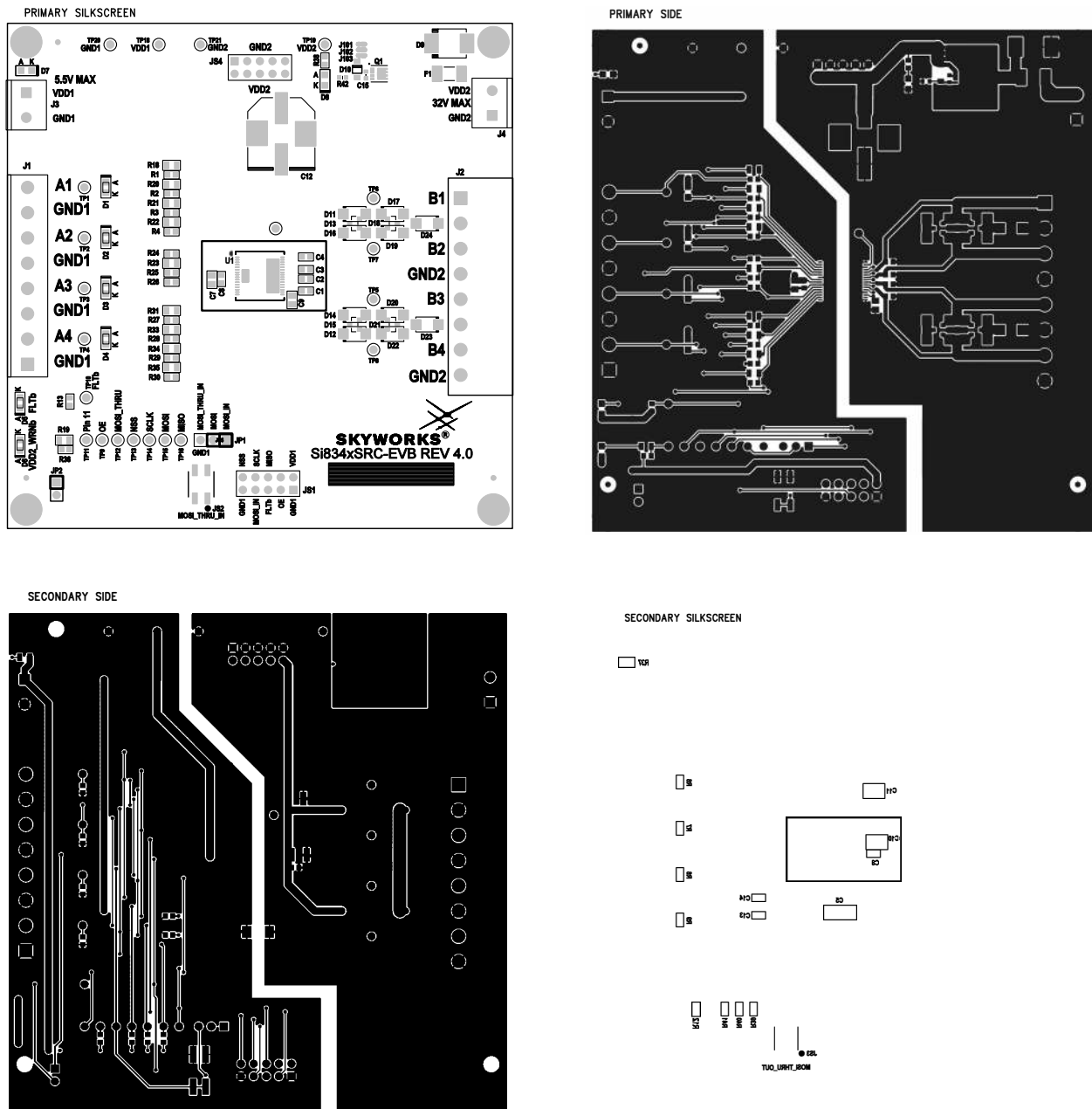

Figure 11. Si834xSRC-EVB Rev 4.0 Layout Files (Primary Silk, Primary, Secondary, Secondary Silk)

5.2. Si834xSNK-EVB Rev 4.0 Layouts

The Si834xSNK-EVB Rev 4.0 PCBs are used for the Si83404AAA-EVB only.

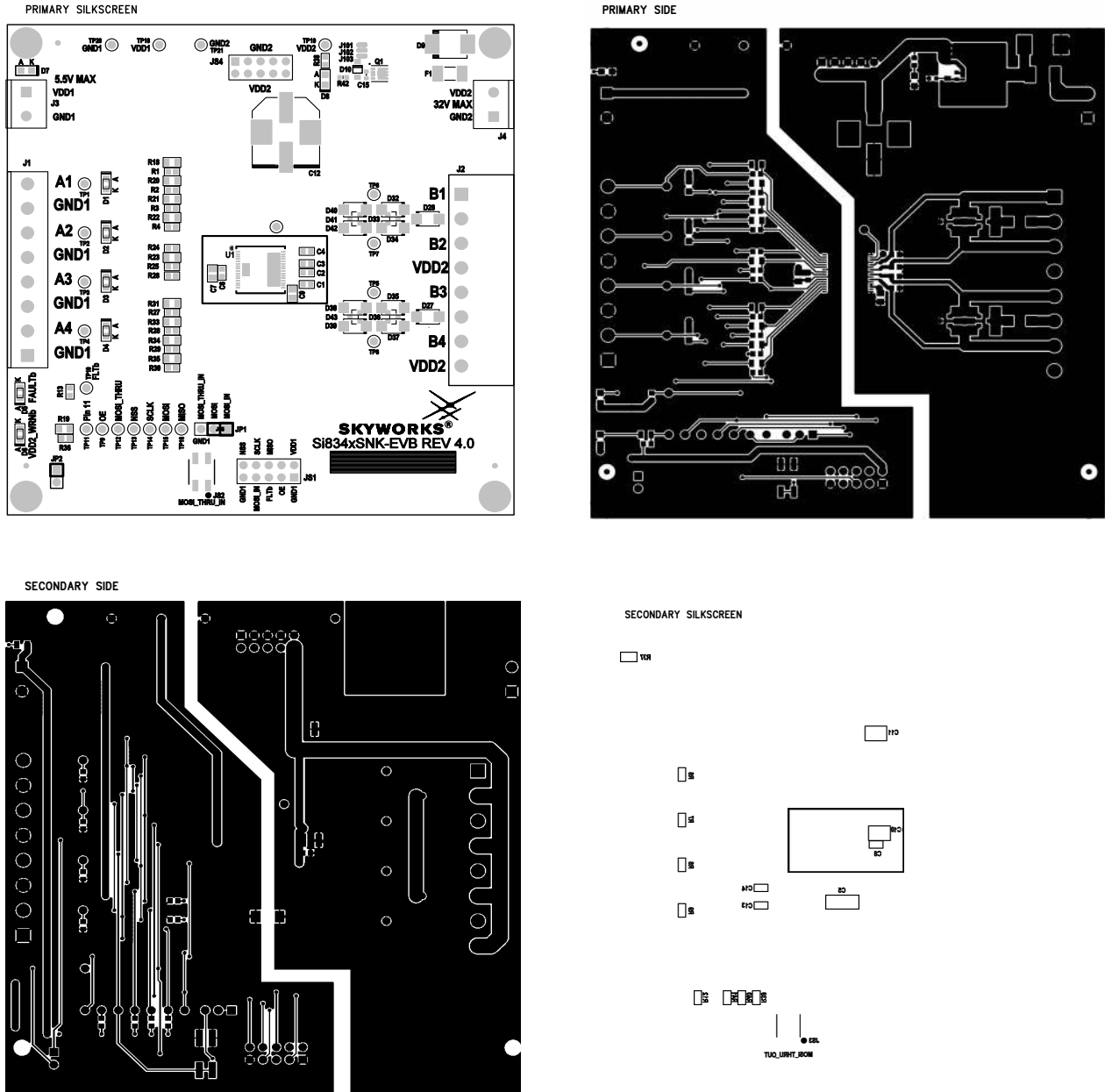

Figure 12. Si834xSNK-EVB Rev 4.0 Layout Files (Primary Silk, Primary, Secondary, Secondary Silk)

5.3. Si83402SRC-EVB Rev 2.0 Layouts

The Si83402SRC-EVB Rev 2.0 PCBs are used for the Si83402BAA-EVB only.

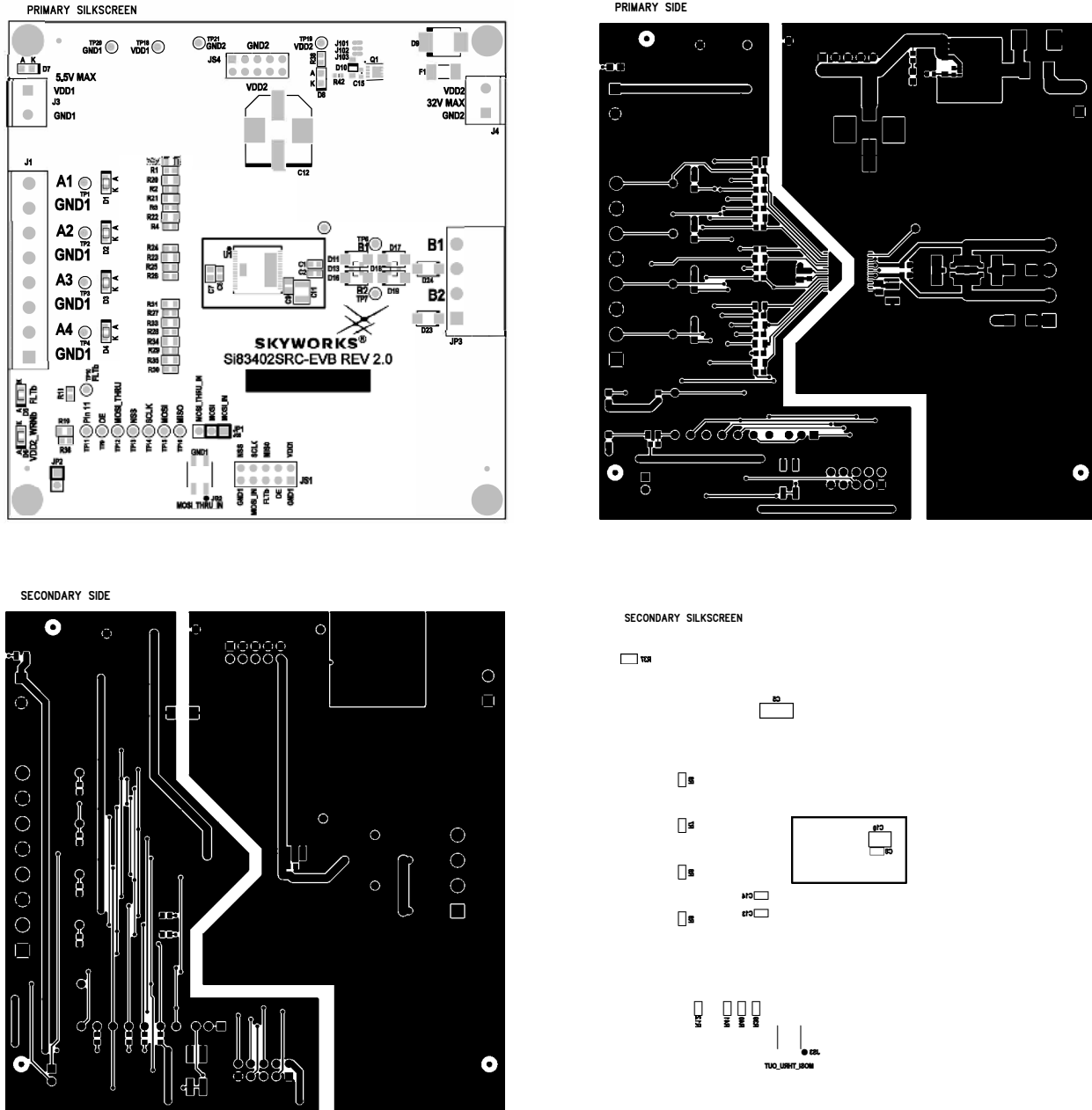

Figure 13. Si83402SRC-EVB Rev 4.0 Layout Files (Primary Silk, Primary, Secondary, Secondary Silk)

5.4. Si83412SNK-EVB Rev 2.0 Layouts

The Si83412SNK-EVB Rev 2.0 PCBs are used for the Si83412BAA-EVB only.

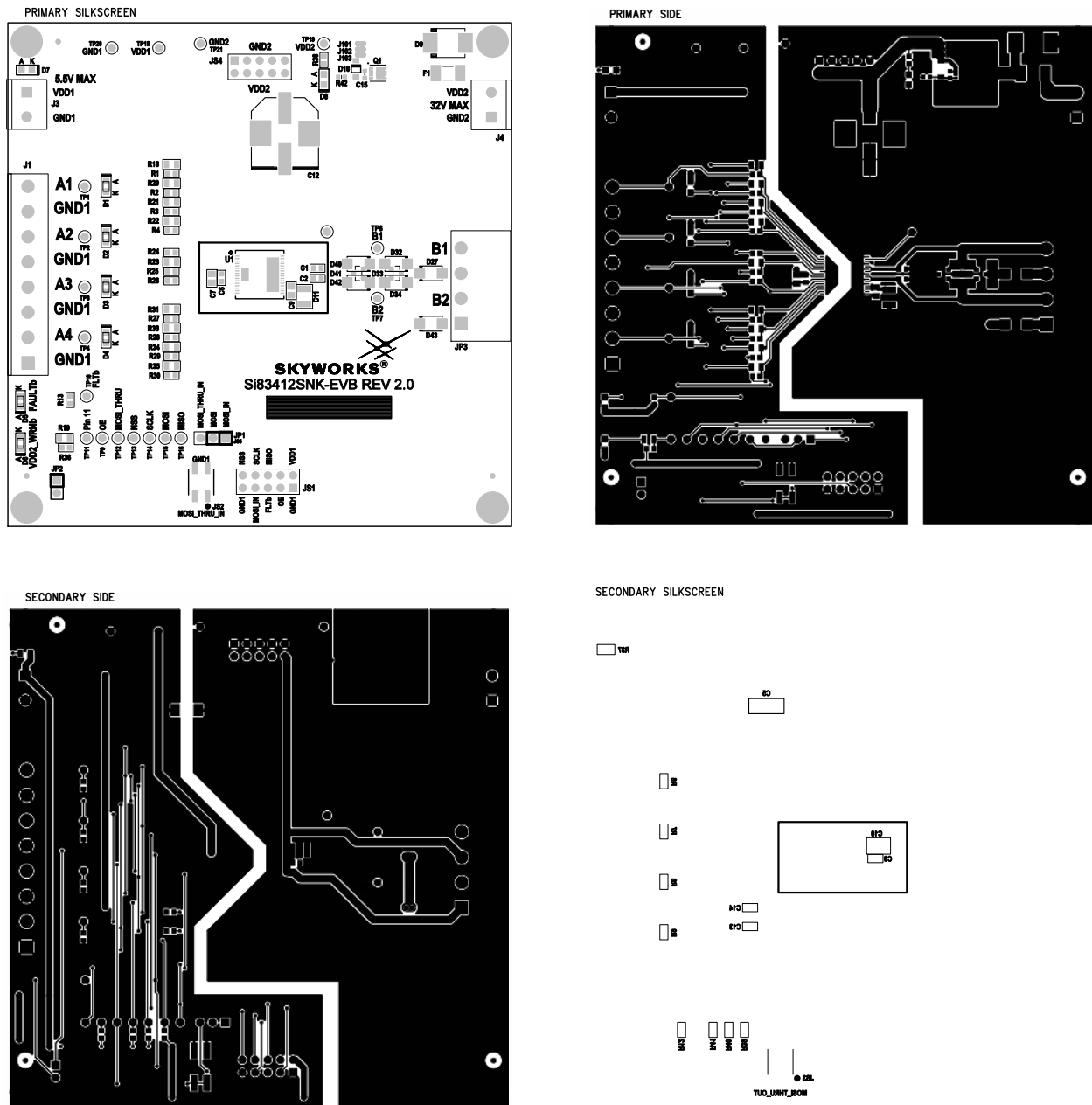

Figure 14. Si83412SNK-EVB Rev 4.0 Layout Files (Primary Silk, Primary, Secondary, Secondary Silk)

5.5. Si83401SRC-EVB Rev 2.0 Layouts

The Si83401SRC-EVB Rev 2.0 PCBs are used for the Si83401BAA-EVB only.

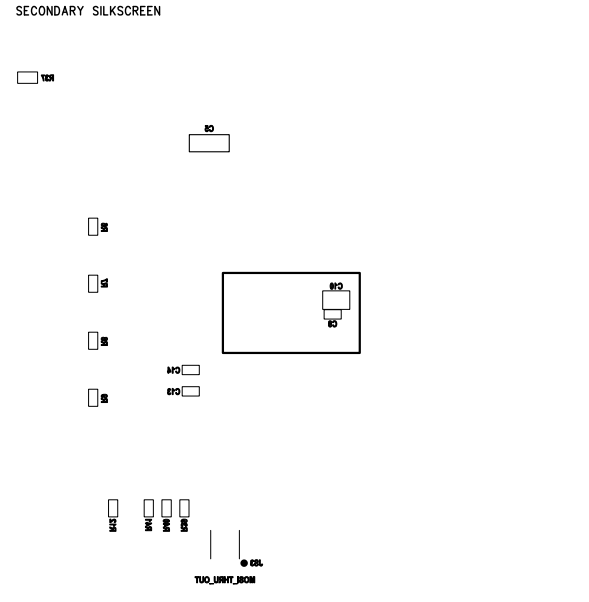
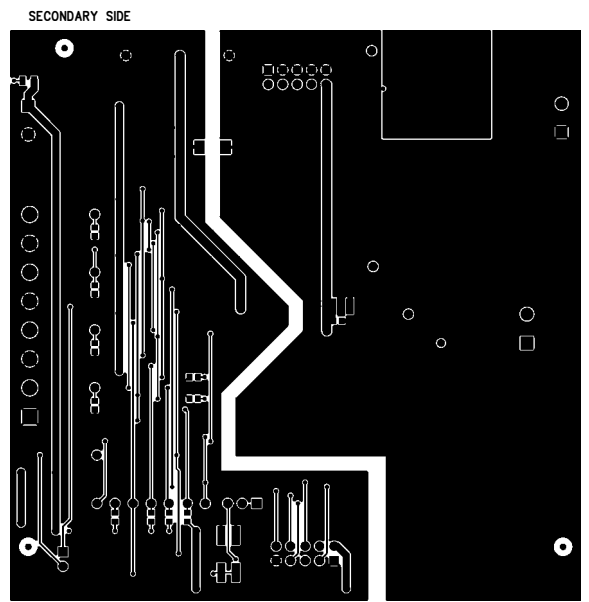
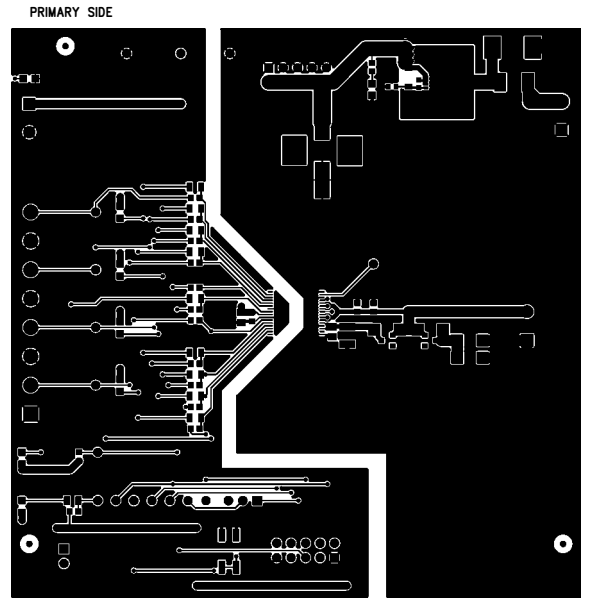
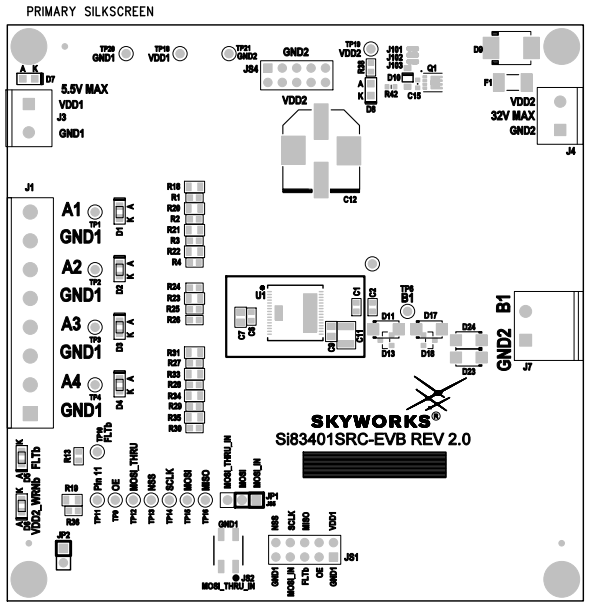

Figure 15. Si83401SRC-EVB Rev 4.0 Layout Files (Primary Silk, Primary, Secondary, Secondary Silk)

5.6. Si83411SNK-EVB Rev 2.0 Layouts

The Si83411SNK-EVB Rev 2.0 PCBs are used for the Si83411BAA-EVB only.

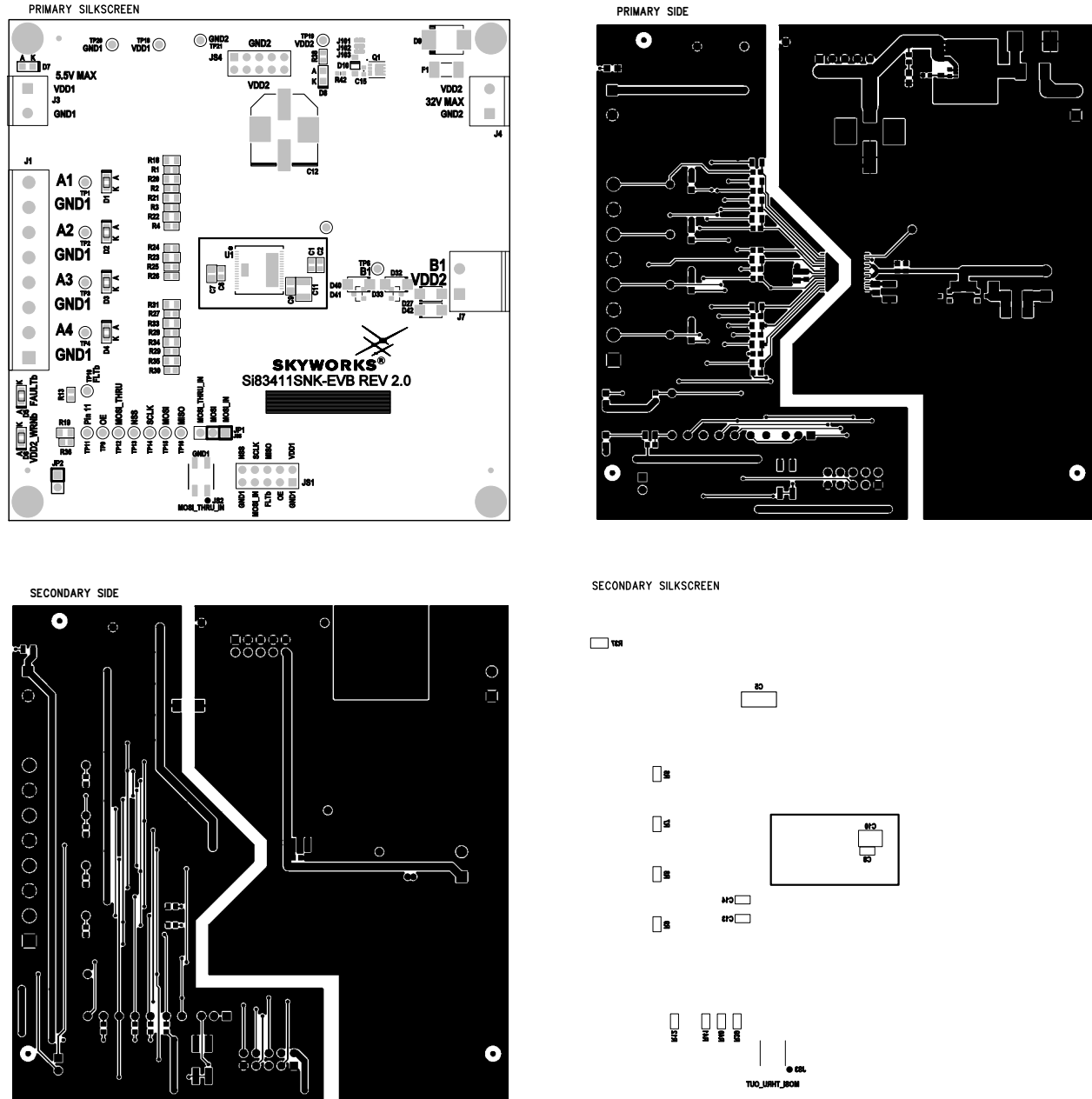

Figure 16. Si83411SNK-EVB Rev 4.0 Layout Files (Primary Silk, Primary, Secondary, Secondary Silk)

Copyright © 2023, Skyworks Solutions, Inc. All Rights Reserved.

Information in this document is provided in connection with Skyworks Solutions, Inc. ("Skyworks") products or services. These materials, including the information contained herein, are provided by Skyworks as a service to its customers and may be used for informational purposes only by the customer. Skyworks assumes no responsibility for errors or omissions in these materials or the information contained herein. Skyworks may change its documentation, products, services, specifications or product descriptions at any time, without notice. Skyworks makes no commitment to update the materials or information and shall have no responsibility whatsoever for conflicts, incompatibilities, or other difficulties arising from any future changes.

No license, whether express, implied, by estoppel or otherwise, is granted to any intellectual property rights by this document. Skyworks assumes no liability for any materials, products or information provided hereunder, including the sale, distribution, reproduction or use of Skyworks products, information or materials, except as may be provided in Skyworks' Terms and Conditions of Sale.

THE MATERIALS, PRODUCTS AND INFORMATION ARE PROVIDED "AS IS" WITHOUT WARRANTY OF ANY KIND, WHETHER EXPRESS, IMPLIED, STATUTORY, OR OTHERWISE, INCLUDING FITNESS FOR A PARTICULAR PURPOSE OR USE, MERCHANTABILITY, PERFORMANCE, QUALITY OR NON-INFRINGEMENT OF ANY INTELLECTUAL PROPERTY RIGHT; ALL SUCH WARRANTIES ARE HEREBY EXPRESSLY DISCLAIMED. SKYWORKS DOES NOT WARRANT THE ACCURACY OR COMPLETENESS OF THE INFORMATION, TEXT, GRAPHICS OR OTHER ITEMS CONTAINED WITHIN THESE MATERIALS. SKYWORKS SHALL NOT BE LIABLE FOR ANY DAMAGES, INCLUDING BUT NOT LIMITED TO ANY SPECIAL, INDIRECT, INCIDENTAL, STATUTORY, OR CONSEQUENTIAL DAMAGES, INCLUDING WITHOUT LIMITATION, LOST REVENUES OR LOST PROFITS THAT MAY RESULT FROM THE USE OF THE MATERIALS OR INFORMATION, WHETHER OR NOT THE RECIPIENT OF MATERIALS HAS BEEN ADVISED OF THE POSSIBILITY OF SUCH DAMAGE.

Skyworks products are not intended for use in medical, lifesaving or life-sustaining applications, or other equipment in which the failure of the Skyworks products could lead to personal injury, death, physical or environmental damage. Skyworks customers using or selling Skyworks products for use in such applications do so at their own risk and agree to fully indemnify Skyworks for any damages resulting from such improper use or sale.

Customers are responsible for their products and applications using Skyworks products, which may deviate from published specifications as a result of design defects, errors, or operation of products outside of published parameters or design specifications. Customers should include design and operating safeguards to minimize these and other risks. Skyworks assumes no liability for applications assistance, customer product design, or damage to any equipment resulting from the use of Skyworks products outside of Skyworks' published specifications or parameters.

Skyworks, the Skyworks symbol, Sky5®, SkyOne®, SkyBlue™, Skyworks Green™, ClockBuilder®, DSPLL®, ISOmodem®, ProSLIC®, SiPHY®, and RFelC® are trademarks or registered trademarks of Skyworks Solutions, Inc. or its subsidiaries in the United States and other countries. Third-party brands and names are for identification purposes only and are the property of their respective owners. Additional information, including relevant terms and conditions, posted at www.skyworksinc.com, are incorporated by reference.