

P	LTR	DESCRIPTION	DATE	DWN	APVD
A		INITIAL RELEASE	22NOV2019	N.S	I.Y
A1		ECR-20-011698	21AUG2020	N.S	I.Y
A2		ECR-20-013035	15SEP2020	N.S	I.Y
A3		ECR-20-015033	22OCT2020	N.S	I.Y

DELIVERY CONDITION AS SHOWN

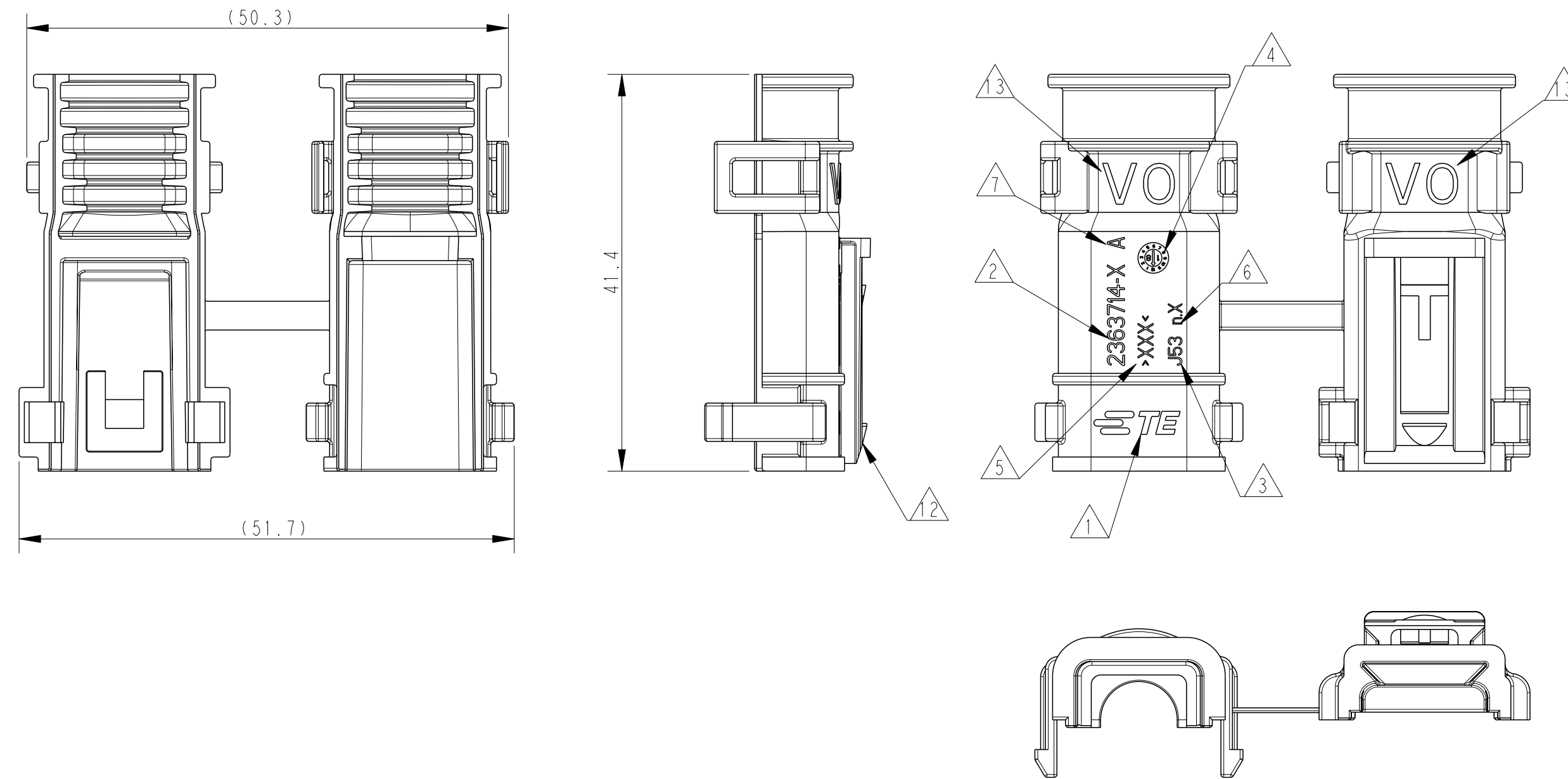

NOTES:

- 1 .TE LEGO
- 2 .TE PART NO.
- 3 .MANUFACTURING LOCATION.
- 4 .DATE CODE.
- 5 .MATERIAL MARKING
- 6 .MOULD CAVITY MARKING
- 7 .PART REVISION
- 8 .FOR CORRUGATED TUBE: NW 6/7.5/8.5/10.
- 9. P/N:2363714 USED ON SSP REC 2P P/N.2327042 AND DT04-2P-XXXX NO CAP VERSION
- 10.BULK PACKAGING IN CORRUGATED BOX
- 11.BASED ON THE HINGE MECHANISM,THE DELIVERY CONDITION CAN BE DIFFERENT TO THE SHOWN STATUS.
- 12.SWALLOW TAIL FOR DIVERSE BRACKETS AND ATTACHMENT CLIPS
- 13 VO MARK, ONLY SHOWS ON PN.2363714-2

CLOSED (MOUNTED) CONDITIONS AS SHOWN

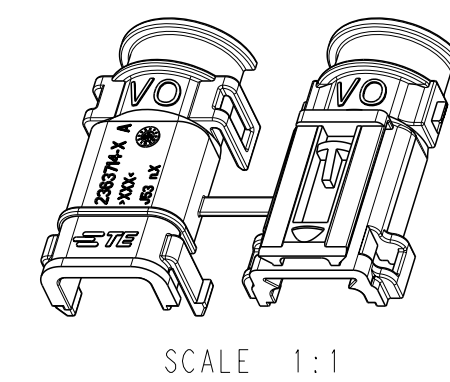
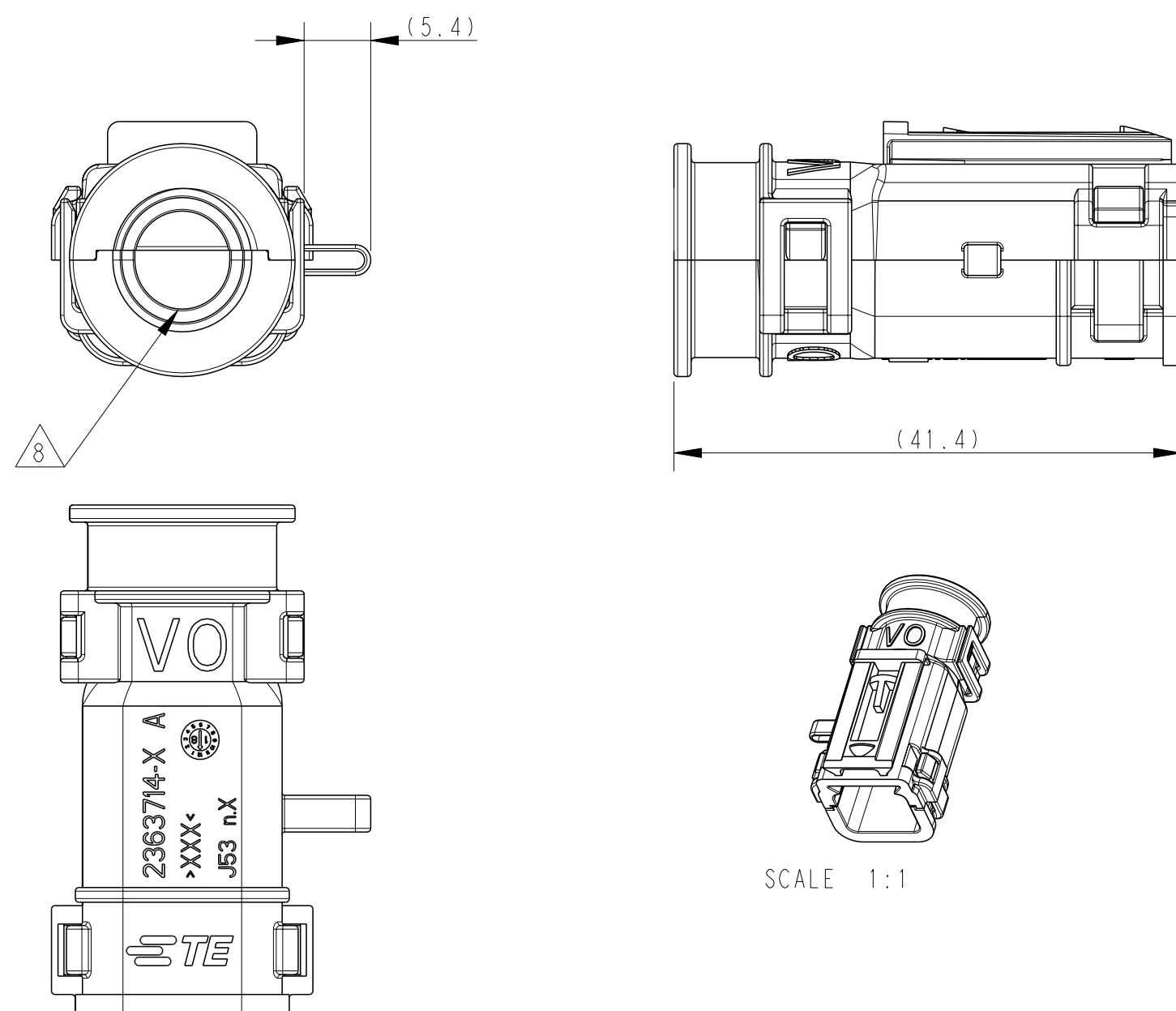

TE P/N	REV	COLOR	DESCRIPTION	ITEM
2363714-2	A	BLACK	180DEG TAB HSG BACKSHELL FOR SUPERSEAL PRO 2P(VO TYPE)	2
2363714-1	A	BLACK	180DEG TAB HSG BACKSHELL FOR SUPERSEAL PRO 2P(HB TYPE)	1

THIS DRAWING IS A CONTROLLED DOCUMENT.

DWN	N. SONG	12NOV2019
CHK	E. JIANG	12NOV2019
APVD	I. YIN	12NOV2019

**STE** TE Connectivity

NAME: TAB HSG BACKSHELL, 2POS, SSP, 180DEG

SIZE	CAGE CODE	DRAWING NO	RESTRICTED TO
A2	00779	C-2363714	

CUSTOMER DRAWING SCALE 2:1 SHEET 1 OF 1 REV A3