

## Brief Description

The ZSSC3016 is a sensor signal conditioner (SSC) integrated circuit for high-accuracy amplification and analog-to-digital conversion of a differential input signal. Designed for high-resolution altimeter module applications, the ZSSC3016 can perform offset, span, and 1<sup>st</sup> and 2<sup>nd</sup> order temperature compensation of the measured signal. Developed for correction of resistive bridge sensors, it can also provide a corrected temperature output measured with an internal sensor.

The measured and corrected bridge values are provided at the digital output pins, which can be configured as I<sup>2</sup>C™\* (≤ 3.4MHz) or SPI (≤ 20MHz). Digital compensation of signal offset, sensitivity, temperature, and non-linearity is accomplished via an 18-bit internal digital signal processor (DSP) running a correction algorithm. Calibration coefficients are stored on-chip in a highly reliable, non-volatile, multiple-time programmable (MTP) memory. Programming the ZSSC3016 is simple via the serial interface and the PC-controlled calibration software provided in the IDT Development Kit. The interface is used for the PC-controlled calibration procedure, which programs the set of calibration coefficients in memory. The digital mating is fast and precise, eliminating the overhead normally associated with trimming external components and multi-pass calibration routines.

## Features

- Flexible, programmable analog front-end design; up to 16-bit scalable, charge-balancing, two-segment analog-to-digital converter (ADC)
- Fully programmable gain amplifier for optimizing sensor signals: gain range 14 to 72 (linear factor)
- Internal auto-compensated temperature sensor
- Digital compensation of individual sensor offset; 1<sup>st</sup> and 2<sup>nd</sup> order digital compensation of sensor gain
- Digital compensation of 1<sup>st</sup> and 2<sup>nd</sup> order temperature gain and offset drift
- Intelligent power management unit
- Typical sensor elements can achieve accuracy of better than ±0.10% FSO @ -40 to 85 °C

## Benefits

- Integrated 18-bit calibration math DSP
- Fully corrected signal at digital output
- Minimize calibration costs through the one-pass calibration concept
- No external trimming components required
- Highly integrated CMOS design
- Layout customized for die-die bonding with sensor for high-density chip-on-board assembly
- Excellent for low-voltage and low-power battery applications

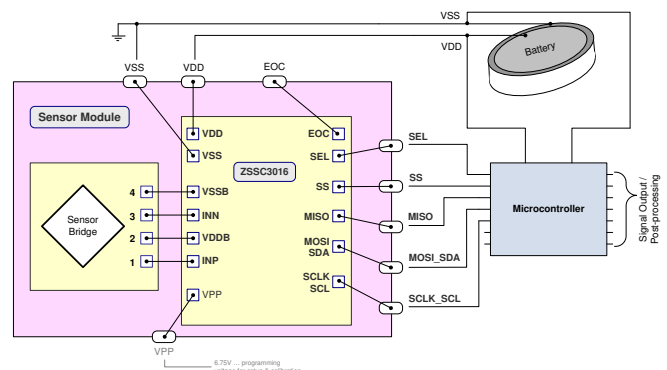
## Support

- Evaluation Kit

## Physical Characteristics

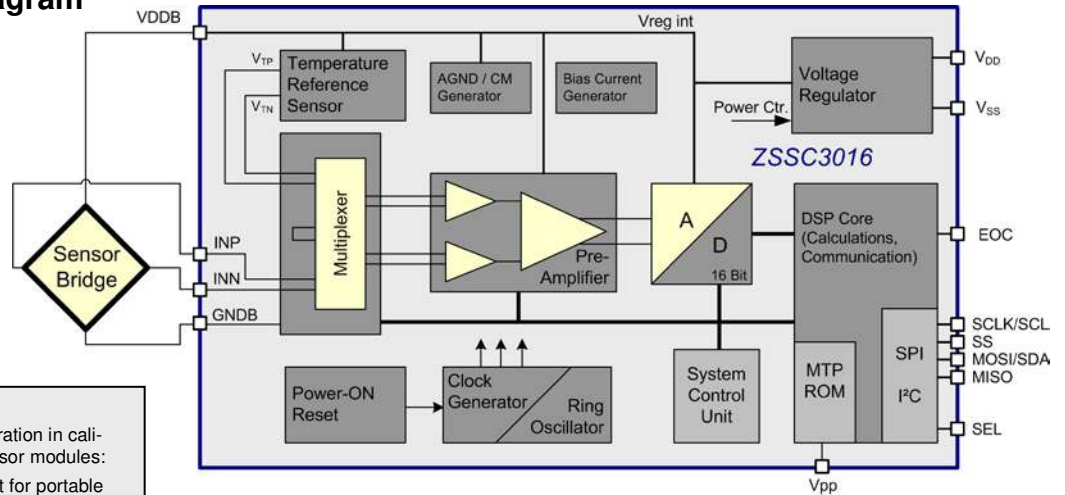
- Supply voltage range: 1.8 to 3.6V
- Current consumption: 1mA (operating mode)
- Sleep State current: 70nA (25°C)
- Temperature resolution: <0.003K/LSB
- Operation temperature: -40°C to +85 °C
- Small die size
- Delivery options: die for wafer bonding

## ZSSC3016 Application Example



\* I<sup>2</sup>C™ is a trademark of NXP.

ZSSC3016 Block Diagram



**Applications**  
 The ZSSC3016 is designed for operation in calibrated resistive (e.g., pressure) sensor modules:

- ❖ Barometric altitude measurement for portable navigation
- ❖ Altitude measurement for emergency call systems and car navigation
- ❖ Inside hard disk pressure measurement
- ❖ Weather forecast
- ❖ Fan control

**Ordering Information** (Contact IDT Sales for additional options.)

Ordering Examples	Description	Package
ZSSC3016CC1B	Temperature range: -40°C to +85°C, consumer-level parameters according to section 1 of the data sheet	Wafer (304µm) unsawn
ZSSC3016CI1B	Temperature range: -40°C to +85°C, industrial-level parameters according to section 1 of the data sheet, 10 years MTP data retention	Wafer (304µm) unsawn
ZSSC3016CI1D ES	Engineering samples, temperature range: -40°C to +85°C	Dice in waffle pack
ZSSC3016KIT	ZSSC3016 Evaluation Kit, including sample and modular evaluation board (Evaluation Software is downloadable from <a href="http://www.IDT.com/ZSSC3016">www.IDT.com/ZSSC3016</a> )	Kit

## Table of Contents

Table of Figures.....	4
List of Tables .....	4
1 IC Characteristics .....	6
1.1. Absolute Maximum Ratings.....	6
1.2. Operating Conditions .....	6
1.3. Electrical Parameters .....	7
1.4. Power Supply Rejection Ratio vs. Frequency .....	9
2 Circuit Description .....	10
2.1. Brief Description .....	10
2.2. Signal Flow and Block Diagram.....	10
2.3. Analog Front End.....	11
2.3.1. Amplifier .....	11
2.3.2. Analog-to-Digital Converter.....	13
2.3.3. Temperature Measurement .....	16
2.3.4. Bridge Supply.....	16
2.4. Digital Section.....	16
2.4.1. Digital Signal Processor (DSP) Core .....	16
2.4.2. MTP Memory.....	17
2.4.3. Clock Generator .....	17
2.4.4. Power Supervision .....	17
2.4.5. Interface .....	17
3 Functional Description.....	18
3.1. Power Up.....	18
3.2. Measurements .....	18
3.3. Operational Modes .....	18
3.4. Command Interpretation.....	21
3.4.1. SPI/I <sup>2</sup> C™ Commands .....	21
3.5. Communication Interface.....	23
3.5.1. Common Functionality .....	23
3.5.2. SPI .....	25
3.5.3. I <sup>2</sup> C™.....	27
3.6. Memory.....	29
3.6.1. Programming Memory .....	29
3.6.2. Memory Status Commands .....	30
3.6.3. Memory Contents.....	31
3.7. Calibration Sequence .....	37
3.7.1. Calibration Step 1 – Assigning Unique Identification .....	37
3.7.2. Calibration Step 2 – Data Collection.....	37

3.7.3.	Calibration Step 3 – Coefficient Calculations.....	38
3.8.	The Calibration Math .....	39
3.8.1.	Bridge Signal Compensation .....	39
3.8.2.	Temperature Signal Compensation .....	41
4	Die Pad Assignments .....	42
5	Quality and Reliability .....	43
6	Ordering Sales Codes .....	43
7	Related Documents .....	44
8	Glossary .....	44
9	Document Revision History .....	45

## Table of Figures

Figure 2.1	ZSSC3016 Functional Block Diagram .....	10
Figure 2.2	ADC Offset.....	15
Figure 3.1	Operational Flow Chart: Power up.....	19
Figure 3.2	Operational Flow Chart: Command Mode and Normal Mode .....	20
Figure 3.3	SPI configuration CPHA=0 .....	25
Figure 3.4	SPI Configuration CPHA=1 .....	26
Figure 3.5	SPI Command Request .....	26
Figure 3.6	SPI Read Status .....	27
Figure 3.7	SPI Read Data .....	27
Figure 3.8	I <sup>2</sup> C™ Command Request .....	28
Figure 3.9	I <sup>2</sup> C™ Read Status.....	28
Figure 3.10	I <sup>2</sup> C™ Read Data .....	29
Figure 3.11	Memory Program Operation .....	30
Figure 4.1	ZSSC3016 Pad Assignments .....	42

## List of Tables

Table 1.1	Maximum Ratings .....	6
Table 1.2	Operating Conditions .....	6
Table 1.3	Constraints for VDD Power-on Reset.....	7
Table 1.4	Electrical Parameters.....	7
Table 2.1	Amplifier Gain: Stage 1 .....	11
Table 2.2	Amplifier Gain: Stage 2.....	12
Table 2.3	Gain Polarity .....	12
Table 2.4	MSB/LSB Settings .....	13

Table 2.5	ADC Conversion Times for a Single A2D Conversion.....	14
Table 2.6	Conversion Times vs. Noise Performance for 16-Bit Fully Signal Conditioned Results (AZBM, BM, AZTM, TM and Digital SSC Correction) .....	14
Table 2.7	ADC Offset Settings.....	16
Table 3.1	SPI/I <sup>2</sup> C™ Commands .....	21
Table 3.2	Get_Raw Commands .....	23
Table 3.3	General Status Byte.....	24
Table 3.4	Status Byte for Read Operations .....	24
Table 3.5	Status Byte for Write Operations .....	24
Table 3.6	Mode Status.....	24
Table 3.7	Memory Status Word .....	30
Table 3.8	MTP Memory Content Assignments .....	31
Table 4.1	Pad Assignments.....	42

# 1 IC Characteristics

## 1.1. Absolute Maximum Ratings

**Table 1.1 Maximum Ratings**

PARAMETER	SYMBOL	Min	TYP	MAX	UNITS
Voltage Reference	V <sub>SS</sub>	0		0	V
Analog Supply Voltage	V <sub>DD</sub>	-0.4		3.63	V
Voltage at all Analog and Digital IO Pins	V <sub>A_IO</sub> , V <sub>D_IO</sub>	-0.5		V <sub>DD</sub> +0.5	V
Input Current into any Pin except Supply Pins <sup>1</sup>	I <sub>in</sub>	-100		100	mA
Electrostatic Discharge Tolerance – Human Body Model (HBM1) <sup>2</sup>	V <sub>HBM1</sub>	2000		-	V
Storage Temperature	T <sub>STOR</sub>	-50		125	°C

<sup>1</sup> Latch-up resistance; reference for pin is 0V.  
<sup>2</sup> HBM1: C = 100pF charged to V<sub>HBM1</sub> with resistor R = 1.5kΩ in series based on MIL 883, Method 3015.7. ESD protection referring to the Human Body Model is tested with devices in ceramic dual in-line packages (CDIP) during product qualification.

## 1.2. Operating Conditions

Reference for all voltages is V<sub>SS</sub>.

**Table 1.2 Operating Conditions**

PARAMETER	SYMBOL	MIN	TYP	MAX	UNIT
Supply Voltage	V <sub>DD</sub>	1.8	-	3.6	V
VDD Rise Time	t <sub>VDD</sub>			200	μs
Bridge Current	I <sub>VDDDB</sub>			600	μA
Operation Temperature Range	T <sub>amb</sub>	-40	-	85	°C
External capacitance between VDDDB and VSS	CL	0.01		50	nF

In order to achieve minimum current consumption in idle mode, a dynamic power-on-reset (POR) circuit is implemented. The VDD low level and the subsequent rise time and VDD rising slope must fulfill specific constraints to guarantee an overall IC reset, respectively.

In general, lower VDD low levels allow for slower rising of the subsequent on-ramp of VDD. The following table shows the relevant reset parameters and conditions. Other combinations may also be possible. The reset trigger can be influenced by increasing the power down time and relaxing, e.g. the VDD rising slope requirement.

**Table 1.3 Constraints for VDD Power-on Reset**

PARAMETER	SYMBOL	MIN	TYP	MAX	UNIT
Power Down Time (duration of VDD Low Level)	$t_{\text{SPIKE}}$	3	-	-	ms
VDD Low Level	$V_{\text{DDlow}}$	0	-	0.2	V
VDD Rising Slope	$SR_{\text{VDD}}$	10	-	-	V/ms

### 1.3. Electrical Parameters

All parameter values are valid only under specified operating conditions. All voltages are referenced to Vss.

**Table 1.4 Electrical Parameters**

PARAMETER	SYMBOL	CONDITIONS/COMMENTS	MIN	TYP	MAX	UNIT
<b>SUPPLY</b>						
Bridge Supply Voltage, ADC Reference Voltage	$V_{\text{DDB}}$	internally generated	1.60	1.67	1.74	V
Current Consumption	$I_{\text{VDD}}$	Active State, average		900	1500	$\mu\text{A}$
		Sleep State at 25°C		70	250	nA
Power Supply Rejection (see <i>Figure 3.1</i> ) $20 \cdot \log_{10}(V_{\text{DD}}/V_{\text{DDB}})$	$PSR_{\text{VDD}}$	where $V_{\text{DD}} = 1.8\text{V}$	17			dB
		where $V_{\text{DD}} = 2\text{V}$	32			dB
Memory Program Voltage	VPP	MTP program at VPP-pin	6.5	6.75	7	V
Mean Program Current	IVPP	MTP program at VPP-pin		2	5	mA
Peak Program Current	$IVPP_{\text{max}}$	MTP Program at VPP-pin, dynamic switch-on current draw for max. 1usec		13	20	mA

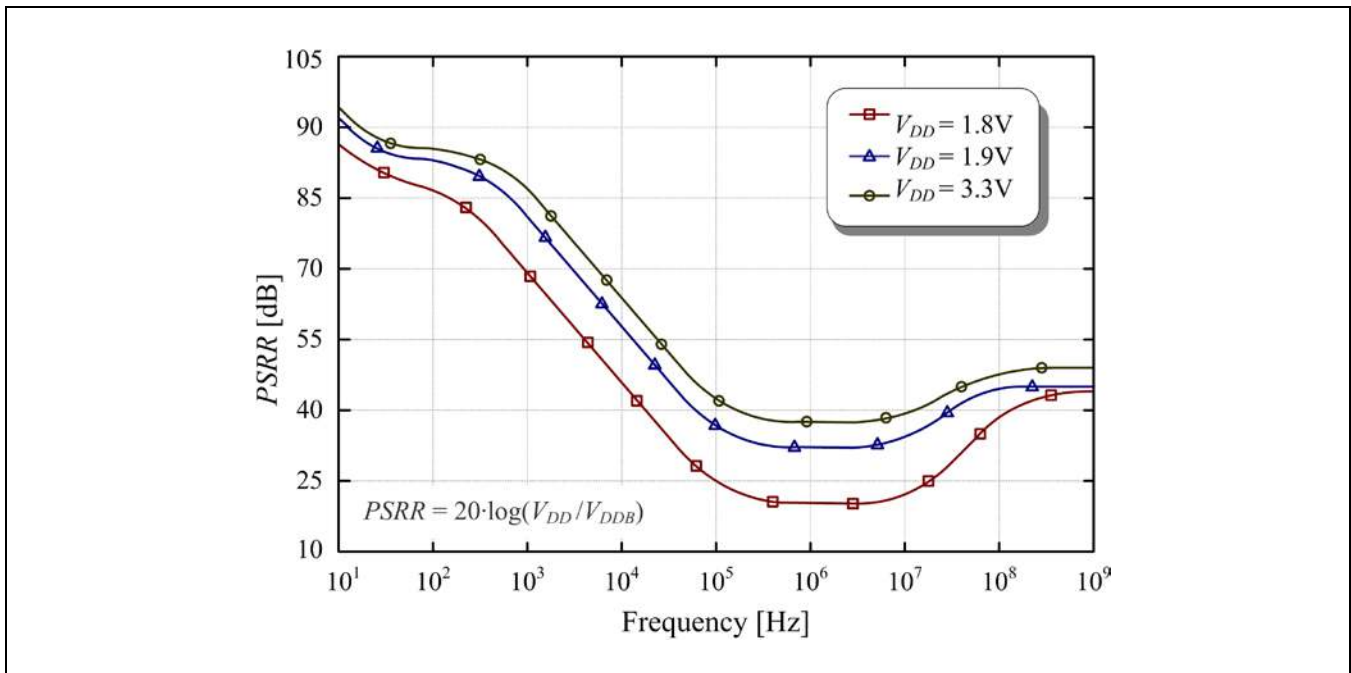
PARAMETER	SYMBOL	CONDITIONS/COMMENTS	MIN	TYP	MAX	UNIT
<b>ANALOG TO DIGITAL CONVERTER (ADC)</b>						
Resolution	$r_{ADC}$		10		16	Bit
ADC Clock Frequency	$f_{ADC}$	Internal ADC clock	0.925	1	1.12	MHz
Reference Voltage n	$V_{refn}$			$V_{DDB} * 0.03$		
Reference Voltage p	$V_{refp}$			$V_{DDB} * 0.97$		
Offset	A2D_Offset	8-step programmable offset	1/16		8/16	
Integral Nonlinearity (INL)	$INL_{ADC}$	Based on ideal slope	-4	-	+4	LSB
Differential Nonlinearity	$DNL_{ADC}$	Tested / verified within design	-1	-	+1	LSB
Conversion Rate, 16bit single	$f_{S,raw}$	Conversions per second for single 16bit A2D conversion	6	-	355	Hz
<b>AMPLIFIER</b>						
Gain	$G_{amp}$	32 steps	13.2		72	
Gain Error	$G_{err}$	referred to nominal gain	-1.5	-	1.5	%
<b>SENSOR SIGNAL CONDITIONING PERFORMANCE</b>						
IC Accuracy Error	$Err_{A,IC}$	Accuracy error for ideally linear (in temperature and e.g. pressure) sensor			0.01	%FS <sub>O</sub>
Conversion Rate, 16bit SSC	$f_{S,SSC}$	Conversion per second for fully corrected 16bit measurement	3		175	Hz
<b>INPUT</b>						
Input Voltage Range	$V_{INP}, V_{INN}$	Input voltage range at INP and INN	0.65		1.05	V
Bridge Resistance	$R_{BR}$		2	10	50	k $\Omega$
<b>POWER UP</b>						
Start-up Time	$t_{STA1}$	$V_{DD}$ ramp up to interface communication			1	ms
	$t_{STA2}$	$V_{DD}$ ramp up to analog operation			2.5	ms
Wake-up Time	$t_{WUP1}$	Sleep to Active State interface communication			0.5	ms
	$t_{WUP2}$	Sleep to Active State analog operation			2	ms

\* Percentage referred to maximum full-scale output; e.g., for 16-bit measurements:  $Err_{A,IC} [\%FSO] = 100 \cdot \text{MAX}\{ |ADC_{meas} - ADC_{ideal}| \} / 2^{16}$



PARAMETER	SYMBOL	CONDITIONS/COMMENTS	MIN	TYP	MAX	UNIT
<b>OSCILLATOR</b>						
Internal Oscillator Frequency	$f_{CLK}$		3.7	4	4.3	MHz
<b>INTERNAL TEMPERATURE SENSOR</b>						
Temperature Resolution		for full range: -40°C to +85°C		0.003		K/LSB
<b>INTERFACE and MEMORY</b>						
SPI Clock Frequency	$f_{C,SPI}$	max. capacitance at MISO-line: 40pF @ $V_{DD}=1.8V$			20	MHz
I <sup>2</sup> C Clock Frequency	$f_{C,I2C}$				3.4	MHz
Program Time	$t_{VPP}$	MTP programming time	500		600	μs
Data Retention	$t_{RET\_MTP}$	for industrial-level IC-version: 1000h @ 150°C	10*			a

#### 1.4. Power Supply Rejection Ratio vs. Frequency



\* With maximum ambient temperature of 85°C

## 2 Circuit Description

### 2.1. Brief Description

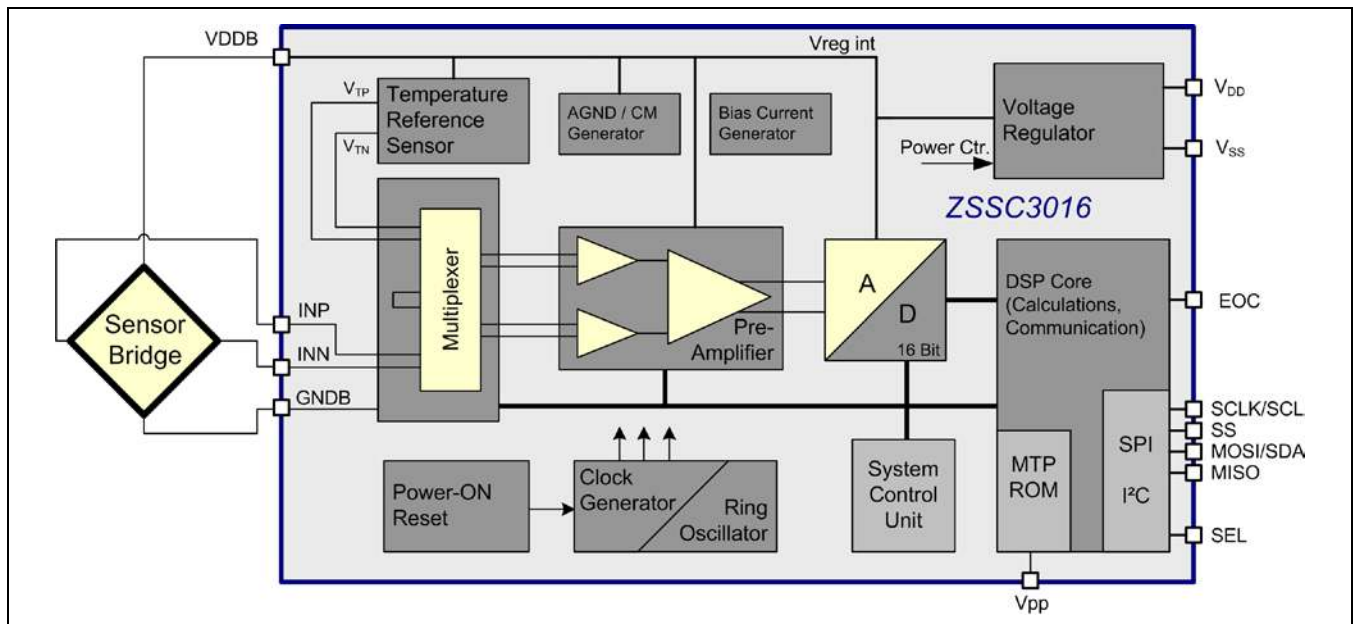
The ZSSC3016 provides a highly accurate amplification of bridge sensor signals. The compensation of sensor offset, sensitivity, temperature drift, and non-linearity is accomplished via an 18-bit DSP core running a correction algorithm with calibration coefficients stored in an MTP memory. The ZSSC3016 can be configured for a wide range of resistive bridge sensor types. A digital interface (SPI or I<sup>2</sup>C™) enables communication. The ZSSC3016 supports two operational modes: *Normal Mode* and *Command Mode*. Normal Mode is supposed to be the mode being used typically, in which the IC wakes up from a Sleep (low power) State, runs a measurement in Active State and turns back automatically to the Sleep State.

### 2.2. Signal Flow and Block Diagram

See Figure 2.1 for the ZSSC3016 block diagram. The sensor bridge supply  $V_{DDB}$  and the power supply for analog circuitry are provided by a voltage regulator, which is optimized for power supply disturbance rejection (PSRR). See section 1.4 for a graph of PSRR versus frequency. To improve noise suppression, the digital blocks are powered by a separate voltage regulator. A power supervision circuit monitors all supply voltages and generates appropriate reset signals for initializing the digital blocks.

The state machine controls the analog circuitry to perform the three measurement types: bridge, temperature, and offset measurement. The multiplexer selects the signal input to the amplifier, which can be the external signals from the input pins INP and INN, the internal temperature reference sensor signals, or an input short for measuring offset. A full measurement request will trigger an automatic sequence of all measurement types and all input signals, respectively. The Temperature Reference Sensor block is based on a bridge-type temperature sensor. The inherit (IC-fabrication related) device mismatch is suppressed by dynamic element matching technique.

Figure 2.1 ZSSC3016 Functional Block Diagram



The amplifier consists of two stages with programmable gain values. The 1/f noise and inherent offset are suppressed by auto-zero and chopper stabilizer techniques. This auto-zero sequence is performed before each bridge sensor and temperature measurement to compensate for the inherent offset of the amplifier.

The ZSSC3016 employs a charge-balancing analog-to-digital converter (ADC) based on switched-capacitor technique with inherent low-pass behavior and noise suppression. The programmable resolution from 10 to 16 bit provides flexibility for adapting the conversion characteristics. To improve power supply noise suppression, the ADC uses the bridge supply  $V_{DDB}$  as its reference voltage.

The remaining IC-internal and the sensor element offset i.e., the overall system offset (amplifier and ADC) can be canceled by an offset and auto-zero measurement, respectively.

The DSP accomplishes the auto-zero, span, and 1<sup>st</sup> and 2<sup>nd</sup> order temperature compensation of the measured bridge signal. The correction coefficients are stored in the MTP memory.

The ZSSC3016 supports SPI and I<sup>2</sup>C™ interface communication for controlling, configuration and measurement result output.

## 2.3. Analog Front End

### 2.3.1. Amplifier

The amplifier has a differential architecture and consists of two stages. The amplification of each stage and the sensor bridge gain polarity are programmable via settings in the Measurement Configuration Register (*BM\_config*) in the MTP memory (see section 2.4.2).

The first five bits of *BM\_config* are the programmable gain settings *Gain\_stage1* and *Gain\_stage2*. The options for the programmable gain settings are listed in Table 2.1 and Table 2.2.

**Table 2.1 Amplifier Gain: Stage 1**

<i>Gain_stage1</i>		
Bit G1	Bit G0	Stage 1 Gain Setting
0	0	12
0	1	20
1	0	30
1	1	40

**Table 2.2 Amplifier Gain: Stage 2**

Gain_stage2			
Bit G4	Bit G3	Bit G2	Stage 2 Gain Setting
0	0	0	1.1
0	0	1	1.2
0	1	0	1.3
0	1	1	1.4
1	0	0	1.5
1	0	1	1.6
1	1	0	1.7
1	1	1	1.8

If needed, the polarity of the sensor bridge gain can be reversed by setting the *Gain\_Polarity* bit in the *BM\_config* register (see section 2.4.2). Changing the gain polarity is achieved by inverting the chopper clock. Table 2.3 gives the settings for the *Gain\_Polarity* bit. This feature enables to apply a sensor to the ZSSC3016 with swapped input signals at INN and INP e.g., to avoid crossing wires for the final sensor module's assembly.

**Table 2.3 Gain Polarity**

Gain_Polarity Bit	Gain	Setting Description
0	+1	No polarity change.
1	-1	Gain polarity is inverted.

The inherent amplifier offset is suppressed by means of auto zero and chopper techniques.

The most appropriate gain and offset setup for a specific sensor element can be determined by these steps:

- 1) Collect the sensor element's characteristic, statistical data (over temperature, ambient sensor parameter and over production tolerances):
  - a. Minimum differential output voltage:  $V_{min}$
  - b. Maximum differential output voltage:  $V_{max}$

*Remark: The best possible setup can only be determined if the absolute value of  $V_{max}$  is bigger than the absolute value of  $V_{min}$ . If this is not the case, the gain polarity should be swapped.*

- 2) If  $V_{min}$  and  $V_{max}$  have different signs (normally:  $V_{max}$  is positive and  $V_{min}$  is negative), then the required ADC offset shift can be selected using the ratio:  $Ratio_{Offset} = |V_{min}| / (V_{max} - V_{min})$   
 Then, the respective offset setup (A2D\_offset) is the nearest integer of multiples of 1/16 in the range of 1/16 to 8/16 (cp. Table 2.7):  $A2D\_offset = Round\_to\_x16^{th}\{Ratio_{Offset}\}$ .

- 3) One of the two following cases is valid.
  - a. If  $\text{Ratio}_{\text{Offset}} - \text{A2D\_offset} \leq 0$  then calculate theoretical optimum gain:  

$$\text{Gain}_{\text{opt}} = (1 - \text{A2D\_offset}) \cdot V_{\text{ref}} / V_{\text{max}}$$
  - b. If  $\text{Ratio}_{\text{Offset}} - \text{A2D\_offset} > 0$  then calculate theoretical optimum gain:  $\text{Gain}_{\text{opt}} = \text{A2D\_offset} \cdot V_{\text{ref}} / |V_{\text{min}}|$   
 with:  $V_{\text{ref}} = V_{\text{refp}} - V_{\text{refn}} = 0.94 \cdot V_{\text{DDB,min}} \sim 1.5\text{V}$
- 4) Select the setup gain ( $\text{Gain}_{\text{setup}}$ ) as the nearest gain to  $\text{Gain}_{\text{opt}}$ , where  $\text{Gain}_{\text{setup}} \leq \text{Gain}_{\text{opt}}$ .

### 2.3.2. Analog-to-Digital Converter

A second-order charge-balancing analog-to-digital converter (ADC) is used to convert the amplifier signal. To allow optimizing the trade-off between conversion time and resolution, the conversion is split into a MSB coarse conversion and an LSB fine conversion. The MSB-LSB segmentation is programmable via the *Msb* and *Lsb* settings in the *BM\_config* register stored in the MTP memory (see section 2.4.2). The final ADC resolution is determined by  $\text{MSB} + \text{LSB} - 1$ . The conversion time is proportional to  $2^{\text{MSB}} + 2^{\text{LSB}}$ . During the MSB coarse conversion, the ADC input signal is sampled and integrated  $2^{\text{MSB}}$  times, resulting in inherent low-pass behavior and noise suppression. Possible settings are listed in Table 2.4.

**Table 2.4 MSB/LSB Settings**

<i>Msb Setup Bits in BM_config</i>	<i>Number of MSB Coarse Conversion Bits</i>	<i>Lsb Setup Bits in BM_config</i>	<i>Number of LSB Fine Conversion Bits</i>
00 <sub>BIN</sub>	10	00 <sub>BIN</sub>	0
01 <sub>BIN</sub>	12	01 <sub>BIN</sub>	3
10 <sub>BIN</sub>	14	10 <sub>BIN</sub>	5
11 <sub>BIN</sub>	16	11 <sub>BIN</sub>	7

Useful MSB/LSB setups are with  $\text{LSB} = 0$  (MSB-only conversions) or combinations of  $\text{MSB} > \text{LSB}$  with  $\text{MSB} + \text{LSB} \leq 17$ . Resolutions beyond 16-bit mainly digitize the collected front-end noise and typically do not improve the system performance. MSB/LSB segmentations with  $\text{LSB} > \text{MSB}$  are also not useful because typically the resolution remains the same as with the inverse MSB/LSB segmentation, but the noise performance becomes significantly worse yet the required conversion time stays the same. The ADC conversion times for different MSB/LSB settings are listed in Table 2.5.

**Table 2.5 ADC Conversion Times for a Single A2D Conversion**

Note: Bold font indicates the preferred settings.

MSB [Bit]	LSB [Bit]	Bridge & Temperature Measurement Conversion Time in $\mu\text{s}$
10	0	1169
12	0	4625
14	0	18449
<b>16</b>	<b>0</b>	<b>73745</b>
10	3	1176
12	3	4632
<b>14</b>	<b>3</b>	<b>18456</b>
10	5	1200
<b>12</b>	<b>5</b>	<b>4656</b>
<b>10</b>	<b>7</b>	<b>1296</b>

**Table 2.6 Conversion Times vs. Noise Performance for 16-Bit Fully Signal Conditioned Results (AZBM, BM, AZTM, TM and Digital SSC Correction)**

Note: Pink shading indicates the default settings for temperature sensor measurement segmentation.

ADC Segmentation: Temperature Sensor [MSB/LSB]	ADC Segmentation: Bridge Sensor [MSB/LSB]	Measurement Duration, MEASURE ( $AC_{HEX}$ ) [ms]	3-sigma Noise for SSC-corrected Output <sup>††</sup> [counts]
10 / 7	10 / 7	5.8	8.6
10 / 7	12 / 5	13.2	6.4
10 / 7	14 / 3	43.0	5.8
10 / 7	16 / 0	164.1	5.6
12 / 5*	10 / 7	13.2	8.4
12 / 5*	12 / 5	20.5	6.4
12 / 5*	14 / 3	50.5	5.6
12 / 5*	16 / 0	170.3	5.1
14 / 3	10 / 7	43.0	7.6
14 / 3	12 / 5	50.5	5.9
14 / 3	14 / 3	80.7	4.4
14 / 3	16 / 0	200.3	4.4

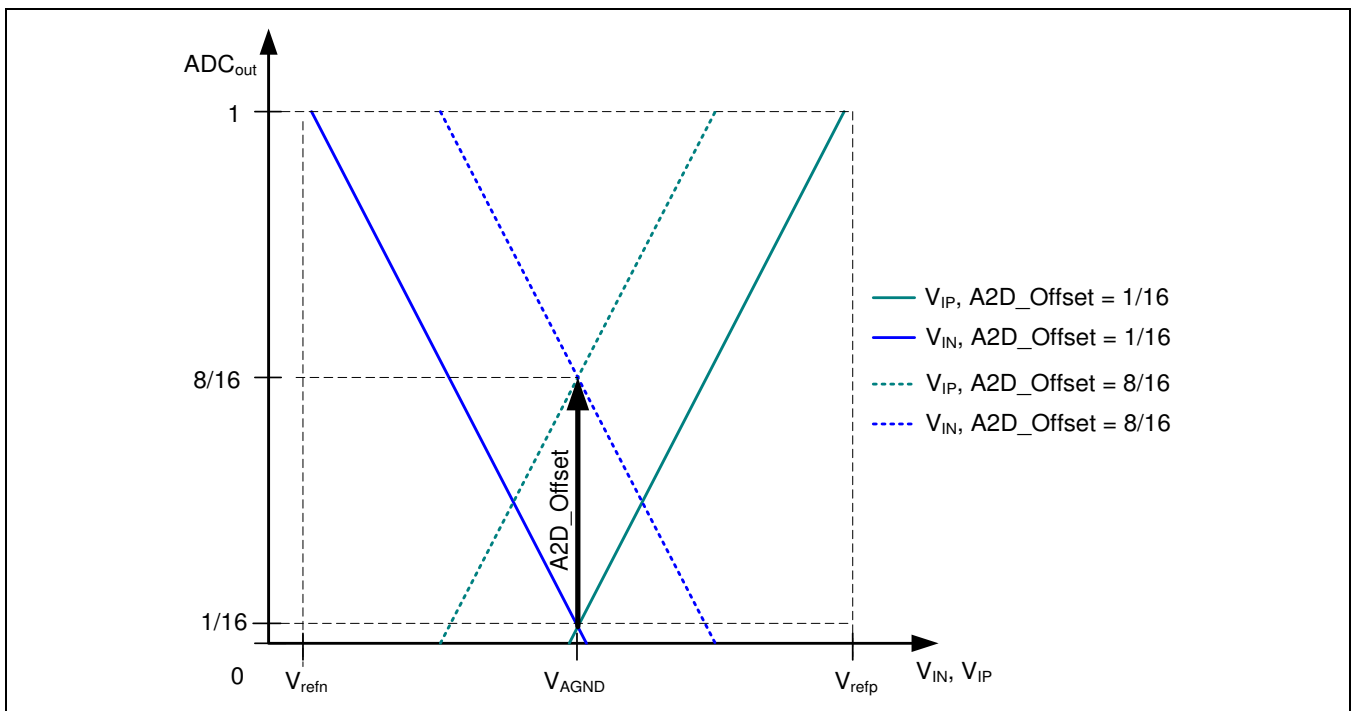
<sup>†</sup> Reference noise values obtained with setup: 13.7kOhm sensor bridge, 25°C, Gain=64, ADC-shift=-1/16...15/16, VDD=1.8V .

<sup>††</sup> IDT-recommendation for temperature sensor measurement's ADC segmentation.

ADC Segmentation: Temperature Sensor [MSB/LSB]	ADC Segmentation: Bridge Sensor [MSB/LSB]	Measurement Duration, MEASURE (AC <sub>HEX</sub> ) [ms]	3-sigma Noise for SSC- corrected Output <sup>†</sup> [counts]
16 / 0	10 / 7	162.6	6.9
16 / 0	12 / 5	170.3	5.4
16 / 0	14 / 3	200.3	4.1
16 / 0	16 / 0	319.5	4.0

The ADC offset is programmable in 8 steps so that the ADC input voltage range can be adapted to the voltage range at the input pins INP and INN. Possible ADC input voltages are shown in Figure 2.2, where  $V_{AGND} = V_{DDB}/2$ . The ADC offset is controlled by the *A2D\_Offset* setting in the Measurement Configuration Register (*BM\_config*) in the MTP memory (see section 2.4.2). The ADC offset settings are listed in Table 2.7.

Figure 2.2 ADC Offset



**Table 2.7 ADC Offset Settings**

Z2	Z1	Z0	ADC Differential Input Range/ $V_{ref}$ Where $V_{ref} = V_{refp} - V_{refn}$	A2D_Offset
0	0	0	-1/16 to 15/16	1/16
0	0	1	-2/16 to 14/16	2/16
0	1	0	-3/16 to 13/16	3/16
0	1	1	-4/16 to 12/16	4/16
1	0	0	-5/16 to 11/16	5/16
1	0	1	-6/16 to 10/16	6/16
1	1	0	-7/16 to 9/16	7/16
1	1	1	-8/16 to 8/16	8/16

### 2.3.3. Temperature Measurement

The ZSSC3016 provides an internal temperature sensor measurement to allow compensation for temperature effects. See section 1.3 for the temperature sensor resolution. The temperature sensor uses bipolar transistors. Any transistor circuitry mismatch is suppressed by dynamic element matching technique. The temperature output signal is a differential voltage that is adapted by the amplifier for the ADC input.

For temperature measurements, the ADC offset and amplifier gain setting are defined by IDT. The ADC MSB/LSB segmentation is programmable by the user for optimizing resolution or conversion time (see section 0). Due to offset cancellation, the MSB conversion for temperature measurement is approximately twice as long as for the other measurements (see Table 2.5).

### 2.3.4. Bridge Supply

The ZSSC3016 provides dedicated bridge supply pins V<sub>DDB</sub> and V<sub>SSB</sub>. The ADC reference voltages for the sensor bridge measurement are derived from these internal voltages so that bridge supply disturbances are suppressed. The current drive ability of V<sub>DDB</sub> is limited (see I<sub>V<sub>DDB</sub></sub> in section 1.2).

## 2.4. Digital Section

### 2.4.1. Digital Signal Processor (DSP) Core

The DSP Core block performs the algorithm for correcting the sensor signal. The resulting coefficients are stored in the MTP memory. When the measurement results are available, the "end of conversion" signal is set at the EOC pin. The internal EOC information is valid only if both the measurement and calculation have been completed.



### 2.4.2. MTP Memory

The ZSSC3016's memory is designed with an OTP (one-time programmable) structure. The memory is organized in 4 one-time programmable pages. When data in the currently valid memory page has to be updated, normally a new page must be selected by increasing the page counter and the whole memory content has to be written in its updated version. The user has access to a 24 x 16 bit storage area for values such as calibration coefficients. Dedicated calibration values are stored in an area not accessible to the user. An external supply at pin VPP is required for programming the OTP (see VPP in section 1.3). There is no over-write or erase function for the MTP memory.

The physical memory function is such that each single bit which has not yet been set to 1 (so, still being 0) can be changed to 1, still. So, it is possible to (partially) re-program an MTP-register, e.g.:

- Assume MTP-address 11<sub>HEX</sub> was written with 8421<sub>HEX</sub> which is 1000 0100 0010 0001<sub>binary</sub>.
- Due to whatever reason there would be the need to change the register content to A6A7<sub>HEX</sub> which is 1010 0110 1010 0111<sub>binary</sub>. This can be achieved by either writing A6A7<sub>HEX</sub> (any already written bit will be ignored automatically) or just writing the difference to 8421<sub>HEX</sub>, which is 2286<sub>HEX</sub>.

The content of a re-written register can generally be determined by:  $\text{content}_{\text{Register}} = \text{content}_{\text{old}} (\text{AND}) \text{content}_{\text{new}}$ . If  $\text{content}_{\text{Register}}$  equals  $\text{content}_{\text{new}}$ , a re-write is possible – this can logically only be guaranteed for  $\text{content}_{\text{old}} = 0000_{\text{HEX}}$ . Or, in other words, depending on the former and the newly intended MTP-address and register content a re-programming could be possible.

### 2.4.3. Clock Generator

The clock generator provides a 4MHz clock signal. The frequency is trimmed during production test.

### 2.4.4. Power Supervision

The Power Supervision block monitors all power supplies to ensure a defined reset of all digital blocks during power-up or power supply interruptions.

### 2.4.5. Interface

The ZSSC3016 can communicate with the user's PC via an SPI or I<sup>2</sup>C™ interface\*. The interface type is selectable via the voltage level on the SEL pin:

- SEL = 0 -> SPI Mode
- SEL = 1 -> I<sup>2</sup>C™ Mode

If the SEL pin is not connected, I<sup>2</sup>C™ communication will be selected (IC-internal pull-up at SEL pin). Further, the SPI-specific pins (like: SS, MISO) do not need to be connected at all for I<sup>2</sup>C operation.

To also provide interface accessibility in Sleep State (all IC features inactive except for the digital interface logic), the interface circuitry is directly supplied by VDD.

\*. Functional I<sup>2</sup>C™ interface properties correspond to the NXP I<sup>2</sup>C™ bus specification Rev. 0.3 (June 2009).

## 3 Functional Description

### 3.1 Power Up

Specifications for this section are given in sections 1.2 and 1.3. On power-up, the ZSSC3016 communication interface is able to receive the first command after a time  $t_{STA1}$  from when the VDD supply is within operating specifications. The ZSSC3016 can begin the first measurement after a time of  $t_{STA2}$  from when the VDD supply is operational.

The wake up time from Sleep State to Active State after receiving the activating command is defined as  $t_{WUP1}$  and  $t_{WUP2}$ . In Command Mode, subsequent commands can be sent after  $t_{WUP1}$ . The first measurement starts after  $t_{WUP2}$  if measurement request was sent.

### 3.2 Measurements

Available measurement procedures are

- AZBM: auto-zero bridge measurement
- BM: bridge measurement
- AZTM: auto-zero temperature measurement
- TM: temperature measurement

**AZBM:** The configuration for bridge measurements is loaded. The Multiplexer connects the Amplifier input to the AGND analog ground reference. An analog-to-digital conversion is performed so that the inherent system offset for the bridge configuration is converted by the ADC to a 16-bit digital word.

**BM:** The configuration for bridge measurements is loaded. The Multiplexer connects the Amplifier input to the bridge pins: INP and INN. An analog-to-digital conversion is performed. The result is a 16-bit digital word.

**AZTM:** The configuration for temperature measurements is loaded. The Multiplexer connects the Amplifier input to AGND. An analog-to-digital conversion is performed so that the inherent system offset for the temperature configuration is converted by the ADC to a 16-bit digital word.

**TM:** The configuration for temperature measurements is loaded. The Multiplexer connects the Amplifier input to the internal temperature sensor. An analog-to-digital conversion is performed. The result is a 16-bit digital word.

The typical application's measurement cycle is a complete SSC-measurement (using the command: AC<sub>HEX</sub>) with AZBM, BM, AZTM, TM followed by a signal correction calculation.

### 3.3 Operational Modes

Figure 3.1 illustrates the ZSSC3016 power-up sequence and subsequent operation depending on the selected interface communication mode (I<sup>2</sup>C™ or SPI). With either interface, after the voltage regulators are switched on, the ZSSC3016's low voltage section (LV) is active while the related interface configuration information is read from memory. Then the LV section is switched off, the ZSSC3016 goes into Sleep State, and the interface is ready to receive commands. Since the interface is always powered by V<sub>DD</sub>, it is referred to as the high voltage section (HV).

Figure 3.2 shows the ZSSC3016 operation in Normal Mode and Command Mode including when the LV and HV sections are active as indicated by the color legend. The Normal Mode automatically returns to Sleep State after executing the requested measurements. In Command Mode, the ZSSC3016 remains active if a dedicated command (Start\_NOM) was sent, which is helpful during calibration. Command Mode can only be entered if Start\_CM is the very first command after POR.

Figure 3.1 Operational Flow Chart: Power up

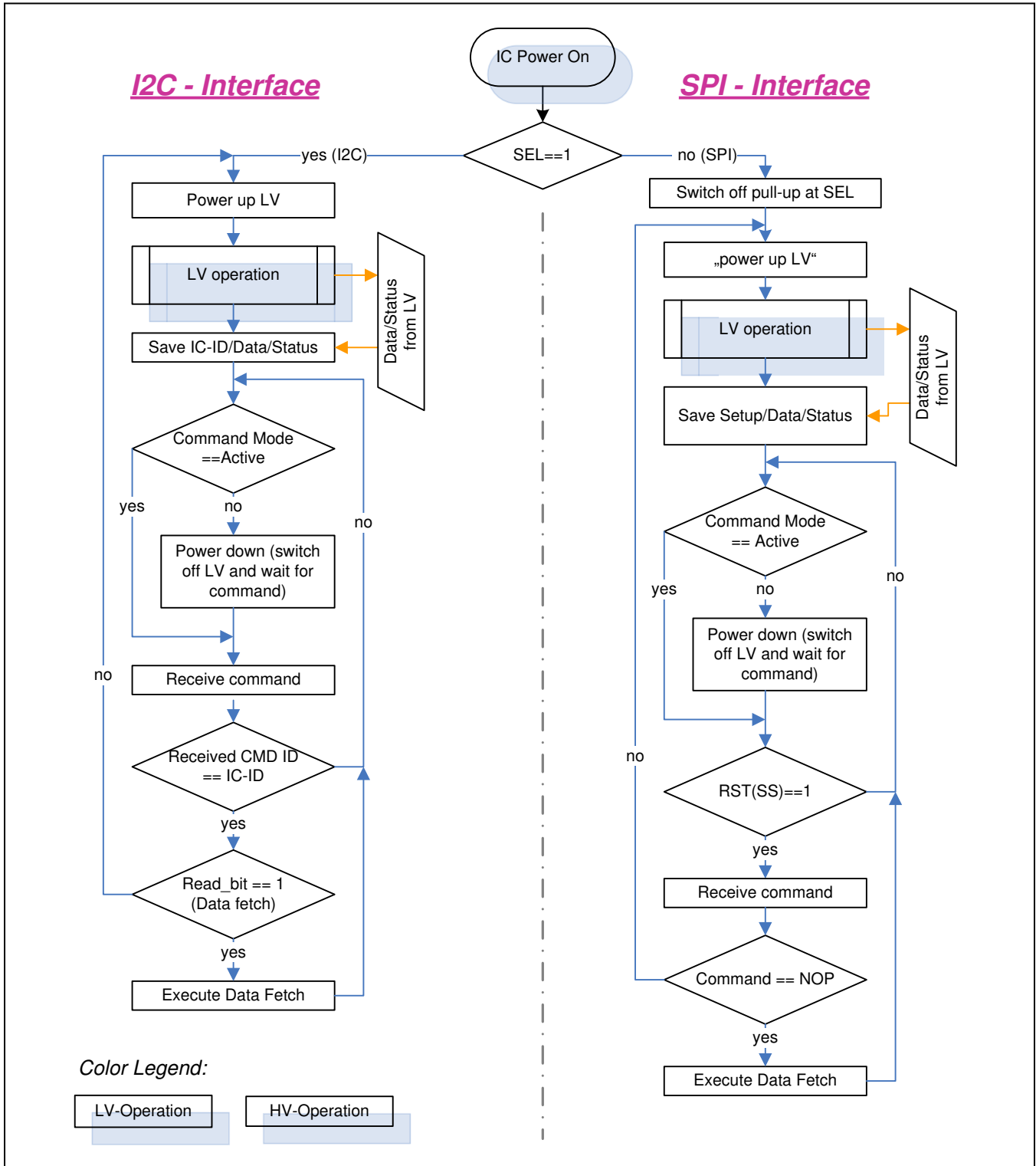
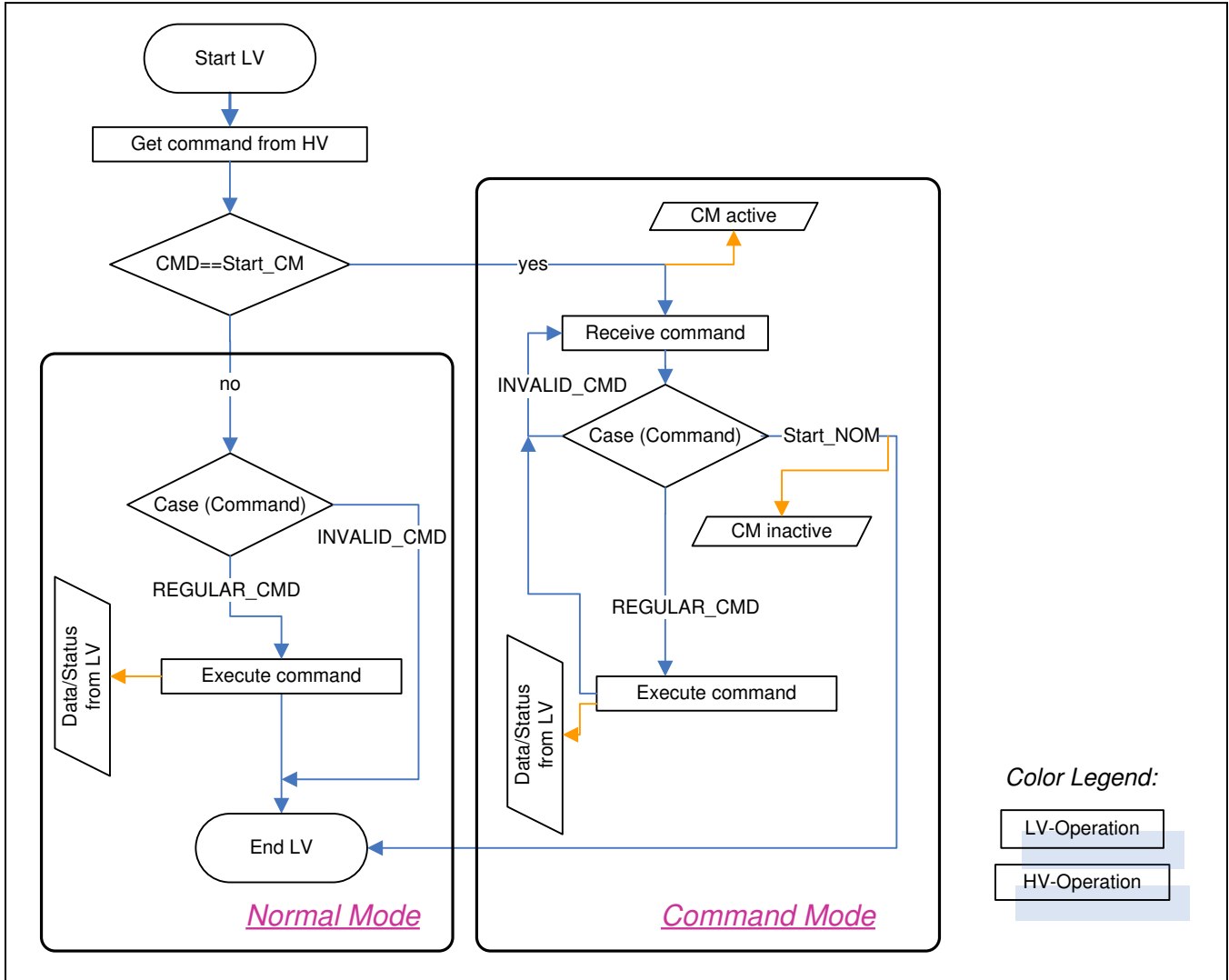


Figure 3.2 Operational Flow Chart: Command Mode and Normal Mode



### 3.4. Command Interpretation

#### 3.4.1. SPI/I<sup>2</sup>C™ Commands

The user-accessible section of memory includes addresses 00<sub>HEX</sub> through 17<sub>HEX</sub> in the OTP memory that is designated by the user memory page pointer. Because each of the four OTP memory pages cannot be rewritten or erased, the memory page pointer must be incremented to the next OTP memory page in order to write to memory again (see Table 3.1 for the command). After all four user-accessible OTP memory pages have been used, further write operations are not possible and the “Memory Full” bit is returned as set in the status byte after write operations (see section 3.5.1).

The SPI/I<sup>2</sup>C™ commands supported by the ZSSC3016 are listed in Table 3.1. The command to read an address in the user memory is the same as its address. The command to read the 16-bit memory status of the data at an address in user memory is the address plus 20<sub>HEX</sub>. The command to write to an address in user memory is the address plus 40<sub>HEX</sub>.

There is a IDT-reserved section of memory, which can be read but not over-written by the user.

**Table 3.1 SPI/I<sup>2</sup>C™ Commands**

Command (Byte)	Returns*	Description	Normal Mode	Command Mode
00 <sub>HEX</sub> to 17 <sub>HEX</sub>	16-bit user data	Read data in user memory address matching command (addresses 00 <sub>HEX</sub> to 17 <sub>HEX</sub> ; might not be using all addresses).	yes	yes
20 <sub>HEX</sub> to 37 <sub>HEX</sub>	16-bit user memory status	Read memory status for address specified by command minus 20 <sub>HEX</sub> (addresses 00 <sub>HEX</sub> to 17 <sub>HEX</sub> respectively; see section 3.6.2 for a description of the memory status).	yes	yes
40 <sub>HEX</sub> to 57 <sub>HEX</sub> + data (0000 <sub>HEX</sub> to FFFF <sub>HEX</sub> )	—	Write data to user memory at address specified by command minus 40 <sub>HEX</sub> (addresses 00 <sub>HEX</sub> to 17 <sub>HEX</sub> respectively; might not be using all addresses).	no	yes
70 <sub>HEX</sub> to 7E <sub>HEX</sub>	16-bit IDT-reserved memory data	Read data in IDT-reserved memory at address specified by command minus 70 <sub>HEX</sub> (2 <sup>nd</sup> set of addresses 00 <sub>HEX</sub> to 0E <sub>HEX</sub> respectively).	no	yes
80 <sub>HEX</sub> to 8E <sub>HEX</sub>	16-bit IDT-reserved memory status	Read memory status bytes for IDT-reserved memory data at address specified by command minus 80 <sub>HEX</sub> (2 <sup>nd</sup> set of addresses 00 <sub>HEX</sub> to 0E <sub>HEX</sub> respectively; see section 3.6.2 for a description of the memory status bytes).	no	yes
5E <sub>HEX</sub>	—	Increment user memory page pointer.	no	yes

\* Every response starts with a status byte followed by the data word as described in section 3.5.1.

Command (Byte)	Returns *	Description	Normal Mode	Command Mode
A0 <sub>HEX</sub> to A7 <sub>HEX</sub> + XXXX <sub>HEX</sub> (see Table 3.2)	16-bit wide raw data	<b>Get_Raw</b> This command can be used to perform a measurement and write the raw ADC data into the output register. The LSB of the command determines how the AFE configuration register is loaded for the Get_Raw measurement (see Table 3.2).	yes	yes
A8 <sub>HEX</sub>	—	<b>Start_NOM</b> Exit Command Mode and transition to Normal Mode. When a Start_NOM command is executed, a flag is checked to see if the user or IDT-reserved memory page was programmed during Command Mode without having written the memory check sum. If so, the device will set "ChecksumC/Z_Flag:=0" (see section 3.5.1).	no	yes
A9 <sub>HEX</sub>	—	<b>Start_CM</b> Exit Normal Mode and transition to Command Mode.	yes	no
AA <sub>HEX</sub>	—	<b>Write_ChecksumC</b> If not yet written, the checksum for the valid user MTP page is calculated and written to MTP. The VPP voltage must be applied before, during, and after this command. <i>ChecksumC_Flag</i> is set to 1 afterwards. If the VPP voltage is NOT available and the write fails, the <i>CheckSumC_Flag</i> remains 0.	no	yes
AC <sub>HEX</sub>	16-bit fully corrected bridge measurement data + 16-bit corrected internal temperature	<b>Measure</b> Triggers full measurement cycle (AZBM, BM, AZTM, TM, as described in section 3.2) and calculation and storage of data in interface (configurations from MTP).	yes	yes
FX <sub>HEX</sub>	Status + last data	<b>NOP</b> Only valid for SPI (see section 3.5.1).	yes	yes

**Table 3.2 Get\_Raw Commands**

Command	Measurement	AFE Configuration Register
A0 <sub>HEX</sub> + 0000 <sub>HEX</sub>	BM – Bridge Measurement	<i>BM_Config</i>
A1 <sub>HEX</sub> + ssss <sub>HEX</sub>	BM – Bridge Measurement	sss is the user's configuration setting for the measurement provided via the interface. The format and purpose of configuration bits must be equal to the definitions for <i>BM_Config</i> .
A2 <sub>HEX</sub> + 0000 <sub>HEX</sub>	BM-AZBM – Auto-Zero corrected Bridge Measurement <sup>1)</sup>	<i>BM_Config</i>
A3 <sub>HEX</sub> + ssss <sub>HEX</sub>	BM-AZBM – Auto-Zero corrected Bridge Measurement <sup>2)</sup>	sss is the user's configuration setting for the measurement provided via the interface. The format and purpose of configuration bits must be equal to the definitions for <i>BM_Config</i> .
A4 <sub>HEX</sub> + 0000 <sub>HEX</sub>	TM – Temperature Measurement	IDT-defined register
A5 <sub>HEX</sub> + ssss <sub>HEX</sub>	TM – Temperature Measurement	sss is the user's configuration setting for the measurement provided via the interface. The format and purpose of configuration bits must be equal to the definitions for <i>BM_Config</i> being valid for temperature measurement in this case (bits [15:13] will be ignored).
A6 <sub>HEX</sub> + 0000 <sub>HEX</sub>	TM-AZTM – Auto-Zero corrected Temperature Measurement <sup>1)</sup>	IDT-defined register
A7 <sub>HEX</sub> + ssss <sub>HEX</sub>	TM-AZTM – Auto-Zero corrected Temperature Measurement <sup>2)</sup>	sss is the user's configuration setting for the measurement provided via the interface. The format and purpose of configuration bits must be equal to the definitions for <i>BM_Config</i> being valid for temperature measurement in this case (bits [15:13] will be ignored).

<sup>1)</sup> Recommended for raw data collection during calibration coefficient determination using pre-programmed (in MTP) measurement setups

<sup>2)</sup> Recommended for raw data collection during calibration coefficient determination using un-programmed (not in MTP), external measurement setups, e.g. for evaluation purposes

### 3.5. Communication Interface

#### 3.5.1. Common Functionality

Commands are handled by the command interpreter in the LV section. Commands that need additional data are not treated differently than other commands because the HV interface is able to buffer the command and all data that belongs to the command and the command interpreter is activated as soon as a command byte is received.

Every response starts with a status byte followed by the data word. The data word depends on the previous command. It is possible to read the same data more than once if the read request is repeated (I<sup>2</sup>C™) or a NOP command is sent (SPI). If the next command is not a read request (I<sup>2</sup>C™) or a NOP (SPI), it invalidates any previous data.

The status byte contains the following bits (see Table 3.3, Table 3.4, and Table 3.5 for sequence):

- Power indication (bit 6): 1 if the device is powered ( $V_{DDB}$  on); 0 if not powered. This is needed for SPI Mode where the master reads all zeros if the device is not powered or in power-on reset (POR).
- Busy indication (bit 5): 1 if the device is busy, which indicates that the data for the last command is not available yet. No new commands are processed if the device is busy.
- Actual ZSSC3016 mode (bits 4:3): 00 = Normal Mode; 01 = Command Mode; 10 = IDT-reserved.
- Memory integrity/error flag (bit 2): 0 if integrity test passed, 1 if test failed. This bit indicates whether the checksum-based integrity check passed or failed. Correctable errors are not reported but can be queried with the memory status commands (see section 3.6.2). The memory error status bit is calculated only during the power-up sequence, so a newly written CRC will only be used for memory verification and status update after a subsequent IC power-on reset (POR).
- Data transfer/correction (bit 1): If the last command was a memory write, this bit is 0 if the last memory write was successful (memory not full yet), otherwise it is 1 (e.g. page increase but being already on last MTP page). If the last command was a memory read, this bit is 1 if the data was corrected.

**Table 3.3 General Status Byte**

Bit	7	6	5	4	3	2	1	0
Meaning	0	Powered?	Busy?	Mode		Memory error?	Data transfer	Special

**Table 3.4 Status Byte for Read Operations**

Bit	7	6	5	4	3	2	1	0
Meaning	0	Powered?	Busy?	Mode		Memory error?	Data corrected?	ALU saturation?

**Table 3.5 Status Byte for Write Operations**

Bit	7	6	5	4	3	2	1	0
Meaning	0	Powered?	Busy?	Mode		Memory error?	Memory full? ⇔ MTP write reject?	Don't care

**Table 3.6 Mode Status**

Status[4:3]	Mode
00	Normal Mode
01	Command Mode
10	IDT-Reserved
11	Command Mode and Reserved

The memory error status bit is only calculated during the power-up sequence, so a newly written CRC will only be used for memory verification after a subsequent power-on reset (POR).



There are two independent checksum flags: *Checksum\_C\_Flag* for the user memory page(s) and *Checksum\_Z\_Flag* for IDT-reserved page(s).

The code assignment for both flags is

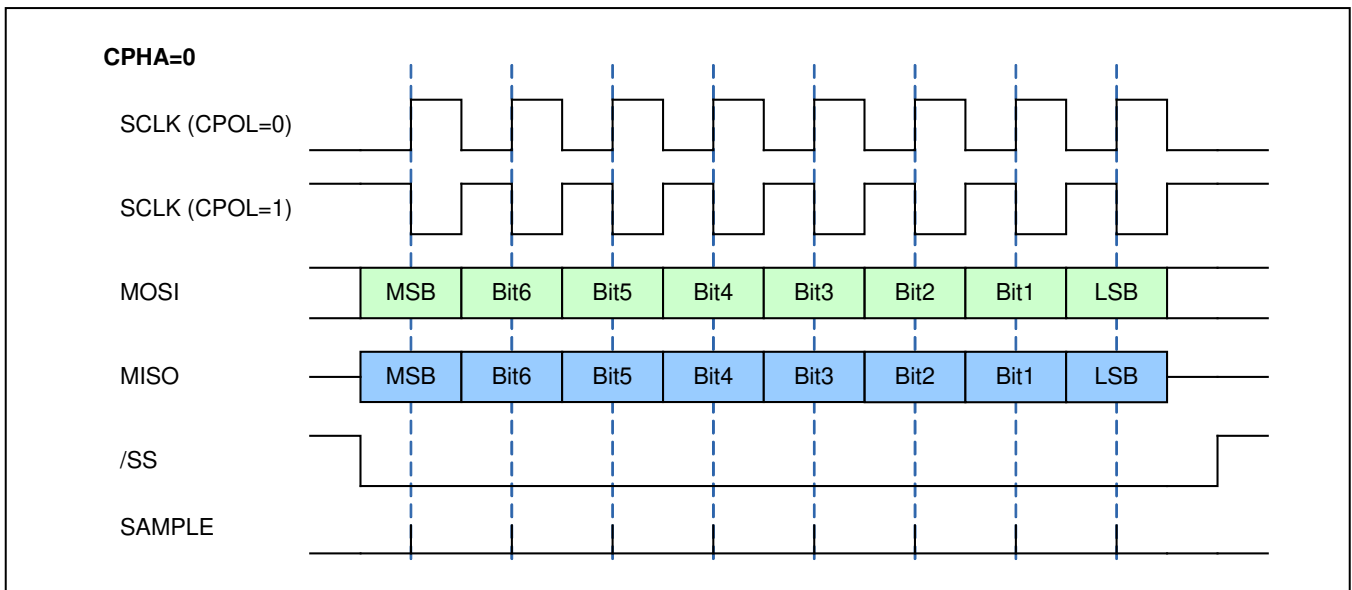
- 0 indicates the checksum (for the IDT/user page) has not been successfully written yet; the checksum still needs to be written.
- 1 indicates the checksum (for the IDT/user page) has successfully been written.

Further status information are provided by the EOC pin. The EOC pin is set high when a measurement and calculation have been completed.

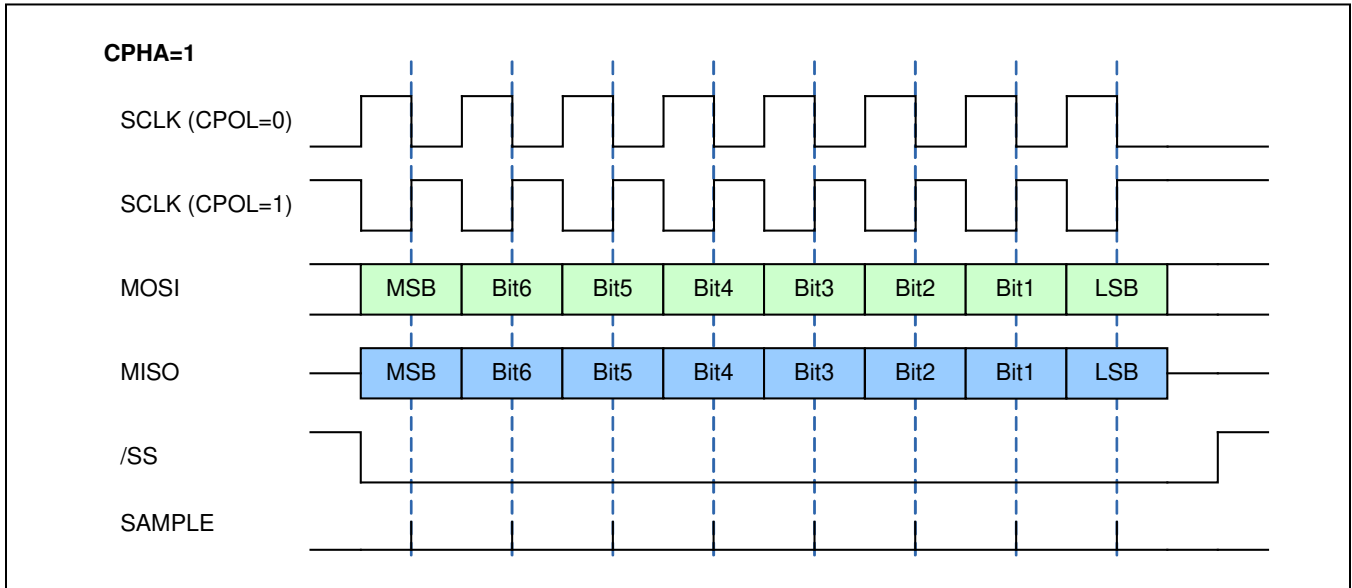
### 3.5.2. SPI

The SPI Mode is available when the SEL pin = 0. The polarity (controlled by CPOL bit) and the phase (controlled by CPHA bit) of the SPI clock (*CKP\_CKE*) and the polarity of the SS signal (*SS\_polarity*) are programmable as described in Table 3.8. CKP\_CKE is two bits: CPHA, which selects which edge of SCLK latches data, and CPOL which indicates whether SCLK is high or low when it is idle. The different combinations of polarity and phase are illustrated in the figures below.

**Figure 3.3 SPI configuration CPHA=0**

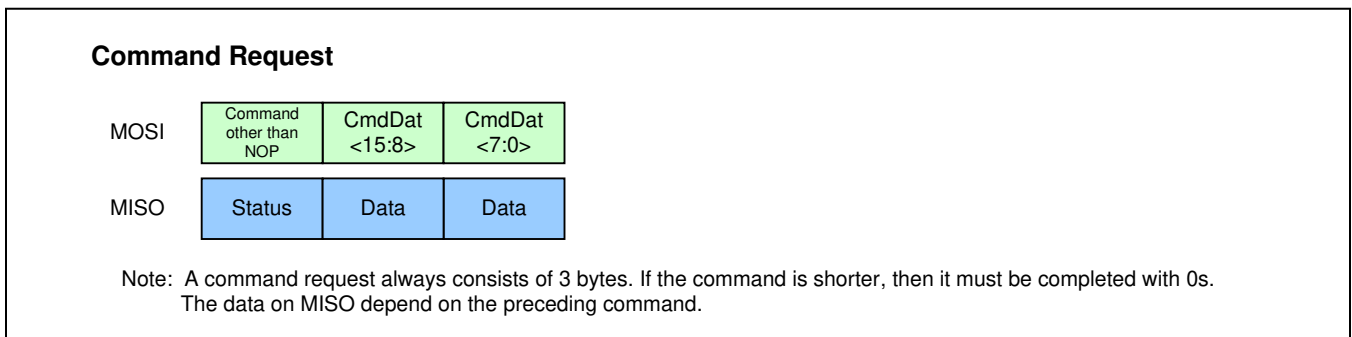


**Figure 3.4 SPI Configuration CPHA=1**



In SPI mode, each command except NOP is started as shown in Figure 3.5. After the execution of a command (busy = 0), the expected data can be read as illustrated in Figure 3.6 or if no data are returned by the command, the next command can be send. The status can be read at any time with the NOP command (see Figure 3.7

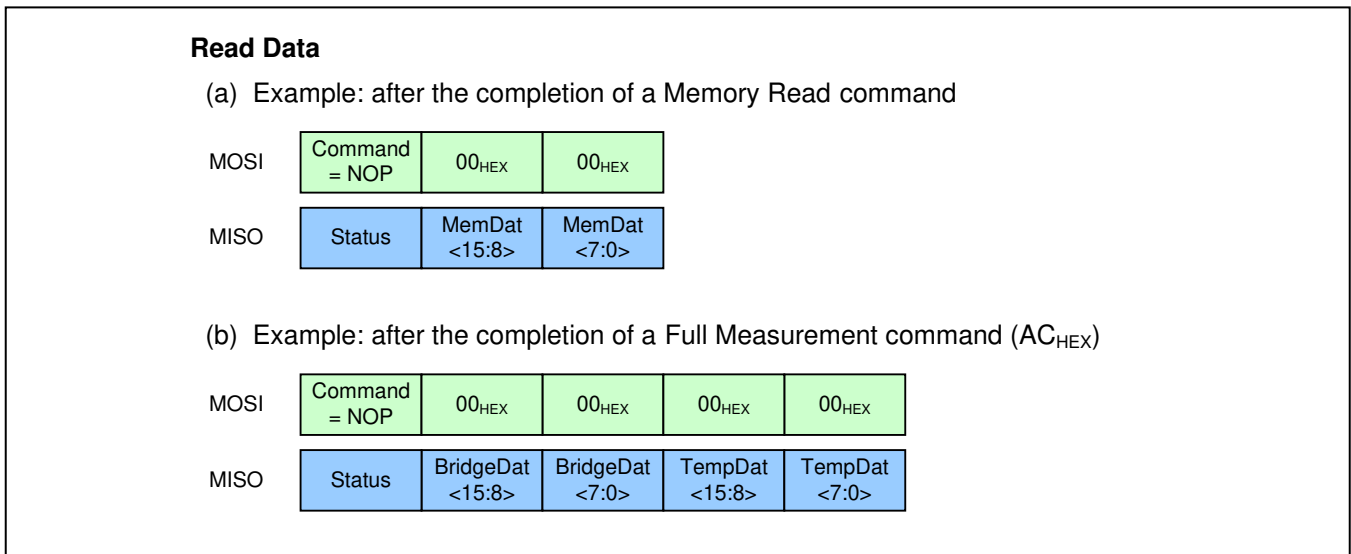
**Figure 3.5 SPI Command Request**



**Figure 3.6 SPI Read Status**



**Figure 3.7 SPI Read Data**



**3.5.3. I<sup>2</sup>C™**

I<sup>2</sup>C™ Mode is selected by SEL = 1. In I<sup>2</sup>C™ Mode, each command is started as shown in figure x.1. Only the number of bytes that is needed for the command has to be sent. An exception is the HS-mode where always 3 Bytes must be sent like in SPI mode. After the execution of a command (busy = 0) the expected data can be read as illustrated in Figure 3.10 or if no data are returned by the command the next command can be sent. The status can be read at any time as described in Figure 3.9.

Figure 3.8 I<sup>2</sup>C™ Command Request

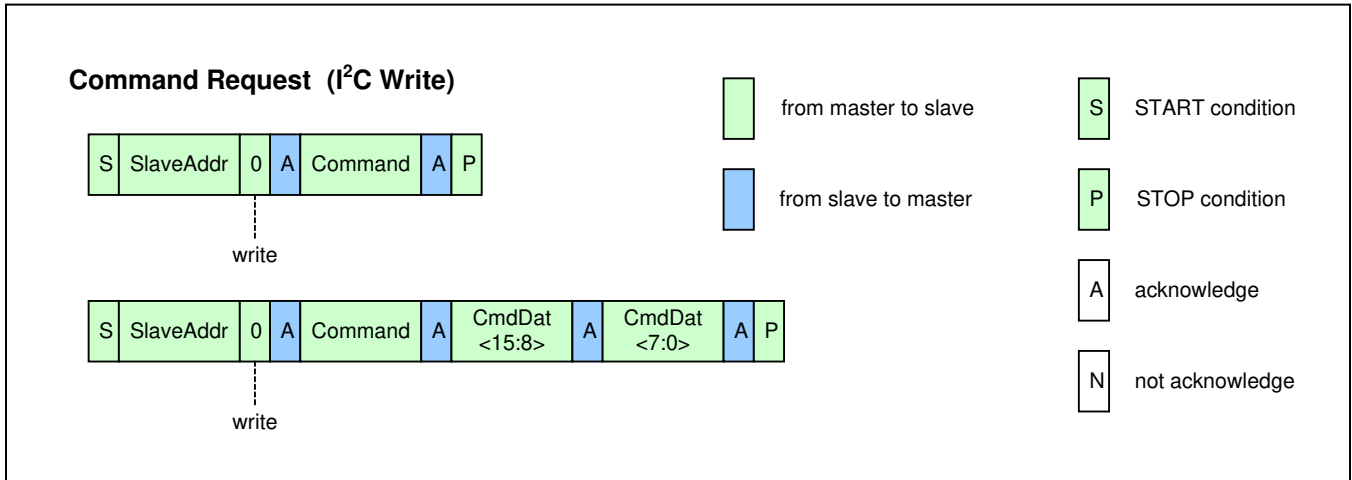


Figure 3.9 I<sup>2</sup>C™ Read Status

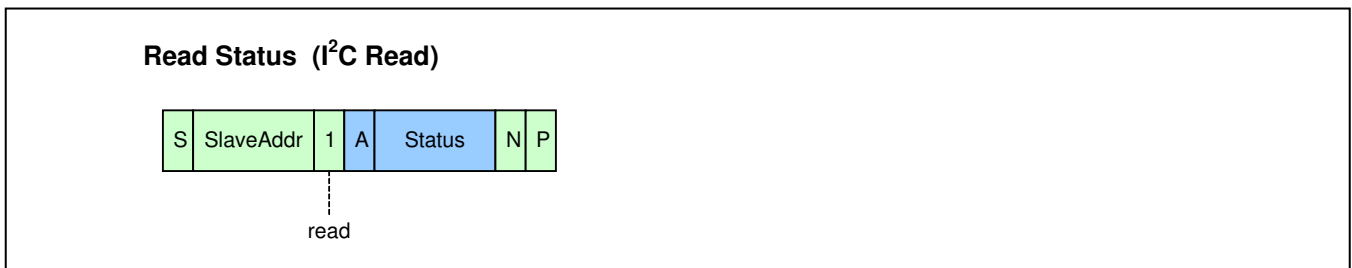
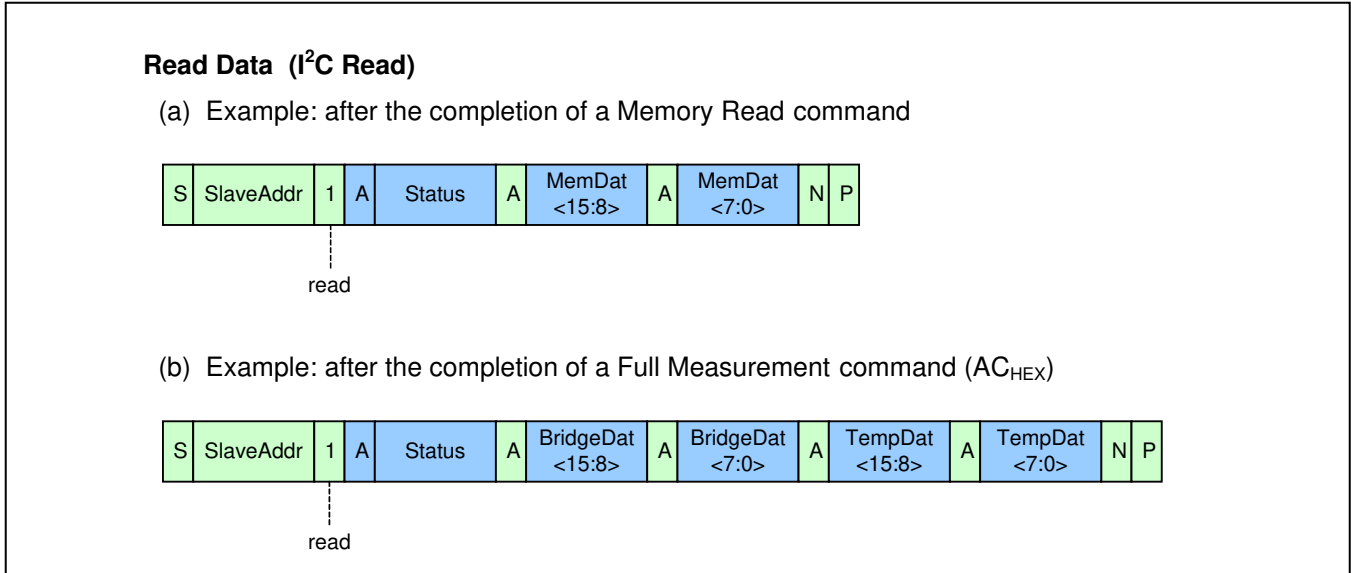


Figure 3.10 I<sup>2</sup>C™ Read Data



All mandatory I<sup>2</sup>C™ bus protocol features are implemented. Optional features like clock stretching, 10-bit slave address, etc., are not supported by the ZSSC3016's interface.

In I<sup>2</sup>C™ High Speed Mode, a command consists of a fixed length of three bytes.

### 3.6. Memory

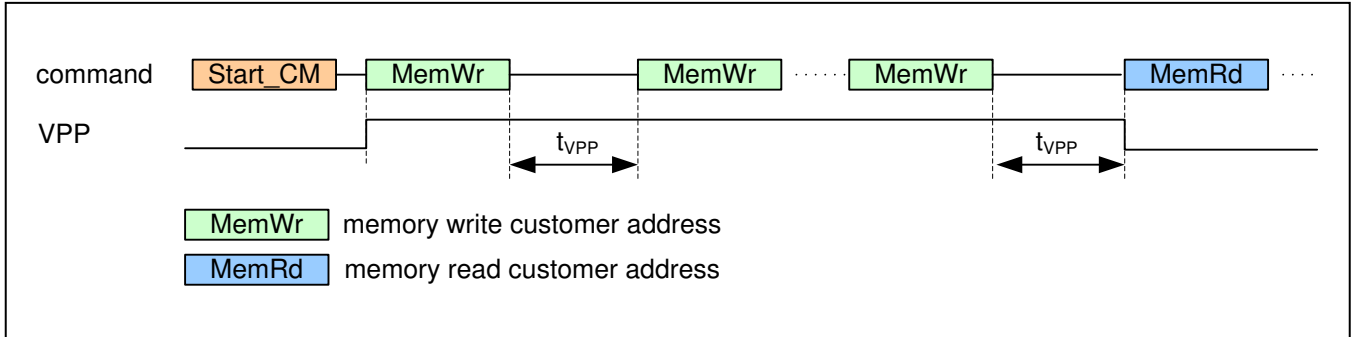
In the ZSSC3016, the memory is organized page-wise and can be programmed multiple (4) times (MTP). The MTP is organized in pages. Each register can only be programmed once per page. The valid page is determined by the page counter which can be incremented with the command 5E<sub>HEX</sub> – this leads to a reset of all registers and a re-programming is necessary. Increasing the customer page counter will disable all old register contents of the former page. It is possible to (re-)program 4 pages totally. Resetting the page counter is not possible. The page counter starts with 0 and can become 3 at maximum. If the 4<sup>th</sup> memory page has been used, no further changes in the memory are possible – careful writing and page incrementing is strongly recommended. There are two MTP page types:

- Customer Page: Accessible by means of regular write operations (40<sub>HEX</sub> to 57<sub>HEX</sub>). It contains: IC-ID, interface setup data, measurement setup information, calibration coefficients, etc.
- IDT Page: Only accessible for write operations by IDT. The IDT page contains specific trim information and is programmed during manufacturing test by IDT.

#### 3.6.1. Programming Memory

Programming memory requires a supply voltage VPP at the VPP pin (see section 1.3 for specifications). The program timing is shown in Figure 3.11. Supplying the ZSSC3016 with VDD>1.8V during memory programming is recommended. After the memory is programmed, it must be read again to verify the validity of the memory content.

**Figure 3.11 Memory Program Operation**



**3.6.2. Memory Status Commands**

The 16-bit memory status answer for the commands: 20<sub>HEX</sub> to 37<sub>HEX</sub> and 80<sub>HEX</sub> to 8E<sub>HEX</sub> contains the following information:

- One bit indicating if the data read was corrected.
- Two bits indicating the current page in use.
- One bit indicating if the respective page's CRC has already been written properly (including having had sufficient programming voltage applied to the VPP pin during the CRC write operation)

**Table 3.7 Memory Status Word**

Bit	Description
15 (MSB)	Data was corrected (0: no, 1: yes)
14	Current page
13	
12	CRC not yet written ( <i>Checksum_C_Flag</i> for user page register or <i>Checksum_Z_Flag</i> for IDT page's register)
11:0	Undefined – do not use

### 3.6.3. Memory Contents

**Table 3.8 MTP Memory Content Assignments.**

MTP Address	Word / Bit Range	Default Setting	Description	Notes / Explanations
00 <sub>HEX</sub>	15:0	0000 <sub>HEX</sub>	Cust_ID0	Customer ID byte 0 (combines with memory word 01 <sub>HEX</sub> to form customer ID)
01 <sub>HEX</sub>	15:0	0000 <sub>HEX</sub>	Cust_ID1	Customer ID byte 1 (combines with memory word 00 <sub>HEX</sub> to form customer ID)
<b>Interface Configuration</b>				
02 <sub>HEX</sub>	6:0	000 0000 <sub>BIN</sub> N	Slave_Addr	I <sup>2</sup> C slave address; valid range: 00 <sub>HEX</sub> to 7F <sub>HEX</sub> (default: 00 <sub>HEX</sub> ), Remark: address codes 04 <sub>HEX</sub> to 07 <sub>HEX</sub> reserved for entering I <sup>2</sup> C™ High Speed Mode
	8:7	00 <sub>BIN</sub>	-	Reserved
	9	0 <sub>BIN</sub>	SS_polarity	Determines the polarity of the Slave Select pin (SS) for SPI operation: <ul style="list-style-type: none"> <li>0 ⇔ Slave Select is active low (SPI &amp; ZSSC3016 are active if SS==0)</li> <li>1 ⇔ Slave Select is active high (SPI &amp; ZSSC3016 are active if SS==1)</li> </ul>
	11:10	00 <sub>BIN</sub>	CKP_CKE	Clock polarity and clock-edge select—determines polarity and phase of SPI interface clock with the following modes: <ul style="list-style-type: none"> <li>00 ⇔ SCLK is low in idle state, data latch with rising edge and data output with falling edge</li> <li>01 ⇔ SCLK is low in idle state, data latch with falling edge and data output with rising edge</li> <li>10 ⇔ SCLK is high in idle state, data latch with falling edge and data output with rising edge</li> <li>11 ⇔ SCLK is high in idle state, data latch with rising edge and data output with falling edge</li> </ul>
	15:12		-	Not assigned

MTP Address	Word / Bit Range	Default Setting	Description	Notes / Explanations
<b>Signal Conditioning Parameters</b>				
03 <sub>HEX</sub>	0	0 <sub>BIN</sub>	Offset_B[16]	Bridge offset, bit[16]—functions as the MSB and combines with Offset_B[15:0] in 05 <sub>HEX</sub> to form the 17-bit coefficient's absolute value
	1	0 <sub>BIN</sub>	Offset_B_sign	Sign for sensor bridge offset (Offset_B): 0 => a positive value or 1 => a negative value
	2	0 <sub>BIN</sub>	Gain_B[16]	Bridge gain, bit[16] —functions as the MSB and combines with Gain_B[15:0] in 06 <sub>HEX</sub> to form the 17-bit coefficient's absolute value
	3	0 <sub>BIN</sub>	Gain_B_sign	Sign of the sensor bridge gain (Gain_B): 0 => a positive value or 1 => a negative value
	4	0 <sub>BIN</sub>	Tcg[16]	1 <sup>st</sup> -order temperature coefficient of the bridge gain, bit[16] —functions as the MSB and combines with Tcg[15:0] in 07 <sub>HEX</sub> to form 17-bit coefficient's absolute value
	5	0 <sub>BIN</sub>	Tcg_sign	Sign off 1 <sup>st</sup> -order temperature coefficient (Tcg): 0 => a positive value or 1 => a negative value
	6	0 <sub>BIN</sub>	Tco[16]	1 <sup>st</sup> -order temperature coefficient of the bridge offset, bit[16] —functions as the MSB and combines with Tco[15:0] in 08 <sub>HEX</sub> to form 17bit coefficient's absolute value
	7	0 <sub>BIN</sub>	Tco_sign	Sign of 1 <sup>st</sup> -order temperature coefficient (Tco): 0 => a positive value or 1 => a negative value
	8	0 <sub>BIN</sub>	SOT_tco[16]	2 <sup>nd</sup> -order temperature coefficient of the bridge offset, bit[16] —functions as the MSB and combines with SOT_tco[15:0] in 09 <sub>HEX</sub> to form 17-bit coefficient's absolute value
	9	0 <sub>BIN</sub>	SOT_tco_sign	Separate setting if 2 <sup>nd</sup> -order temperature coefficient (SOT_tco) is: 0 => a positive value or 1 => a negative value
	10	0 <sub>BIN</sub>	SOT_tcg[16]	2 <sup>nd</sup> -order temperature coefficient of the bridge gain, bit[16] —functions as the MSB and combines with SOT_tcg[15:0] in 0A <sub>HEX</sub> to form 17-bit coefficient's absolute value
	11	0 <sub>BIN</sub>	SOT_tcg_sign	Separate setting (sign) if 2 <sup>nd</sup> -order temperature coefficient (SOT_tcg) is: 0 => a positive value or 1 => a negative value



MTP Address	Word / Bit Range	Default Setting	Description	Notes / Explanations
	12	0 <sub>BIN</sub>	SOT_bridge[16]	2 <sup>nd</sup> -order coefficient of the bridge signal, bit[16] — functions as the MSB and combines with SOT_bridge[15:0] in 0B <sub>HEX</sub> to form 17-bit coefficient's absolute value
	13	0 <sub>BIN</sub>	SOT_bridge_sign	Separate setting if 2 <sup>nd</sup> -order bridge coefficient (SOT_bridge) is 0 => a positive value or 1 => a negative value
	14	0 <sub>BIN</sub>	SOT_curve	Type of second order curve correction for the bridge sensor signal. 0 ⇔ parabolic curve 1 ⇔ s-shaped curve
	15	0 <sub>BIN</sub>	TSETL_sign	Separate setting T_SETL is 0 => a positive value or 1 => a negative value
04 <sub>HEX</sub>	0	0 <sub>BIN</sub>	Gain_T[16]	Temperature gain of temperature sensor, bit[16] functions as the MSB and combines with Gain_T[15:0] in 0D <sub>HEX</sub> to form 17-bit coefficient's absolute value
	1	0 <sub>BIN</sub>	Gain_T_sign	Separate setting if the temperature gain (Gain_T) is: 0 => a positive value or 1 => a negative value
	2	0 <sub>BIN</sub>	SOT_T[16]	2 <sup>nd</sup> -order temperature coefficient of temp. sensor, bit[16] functions as the MSB and combines with SOT_T[15:0] in 0E <sub>HEX</sub> to form 17-bit coefficient's absolute value
	3	0 <sub>BIN</sub>	SOT_T_sign	Separate setting if 2 <sup>nd</sup> -order temperature coefficient (SOT_T) is 0 => a positive value or 1 => a negative value
	4	0 <sub>BIN</sub>	Offset_T[16]	Temperature offset of temp. sensor, bit[16] functions as the MSB and combines with Offset_T[15:0] in 0C <sub>HEX</sub> to form 17-bit coefficient's absolute value
	5	0 <sub>BIN</sub>	Offset_T_sign	Separate setting if the temperature offset (Offset_T) is 0 => a positive value or 1 => a negative value
	15:6	0 0000 000 0 <sub>BIN</sub>	-	Not assigned

MTP Address	Word / Bit Range	Default Setting	Description	Notes / Explanations
05 <sub>HEX</sub>	15:0	0000 <sub>HEX</sub> (7000 <sub>HEX</sub> )	Offset_B[15:0]	<p>Bits [15:0] of the bridge offset correction coefficient, which is an 18-bit wide absolute value (the respective MSBs Offset_B[16] and sign, Offset_B_sign, are under bits[1:0] in 03<sub>HEX</sub>)</p> <p>[-1/16 to 15/16] = 7000<sub>HEX</sub> (default for volume)            [-2/16 to 14/16] = 6000<sub>HEX</sub>            [-3/16 to 13/16] = 5000<sub>HEX</sub>            [-4/16 to 12/16] = 4000<sub>HEX</sub>            [-5/16 to 11/16] = 3000<sub>HEX</sub>            [-6/16 to 10/16] = 2000<sub>HEX</sub>            [-7/16 to 9/16] = 1000<sub>HEX</sub>            [-8/16 to 8/16] = 0000<sub>HEX</sub> (default for prototypes)</p>
06 <sub>HEX</sub>	15:0	0000 <sub>HEX</sub> (8000 <sub>HEX</sub> )	Gain_B[15:0]	<p>Bits[15:0] of 17-bit wide absolute value of the bridge gain coefficient (default for prototypes: 0000<sub>HEX</sub>; default for volume production: 8000<sub>HEX</sub>—the respective MSBs, Gain_B[16] and sign, Gain_B_sign, are under bits[3:2] in 03<sub>HEX</sub>)</p>
07 <sub>HEX</sub>	15:0	0000 <sub>HEX</sub>	Tcg[15:0]	<p>Coefficient for temperature correction of the bridge gain term – the respective MSBs, Tcg[16] and sign, Tcg_sign, are under (bits[5:4] in 03<sub>HEX</sub>)</p>
08 <sub>HEX</sub>	15:0	0000 <sub>HEX</sub>	Tco[15:0]	<p>Coefficient for temperature correction of the bridge offset term – the respective MSBs, Tco[16] and sign, Tco_sign, are under (bits[7:6] in 03<sub>HEX</sub>)</p>
09 <sub>HEX</sub>	15:0	0000 <sub>HEX</sub>	SOT_tco[15:0]	<p>2<sup>nd</sup> order term applied to Tco – the respective MSBs, SOT_tco[16] and sign, SOT_tco_sign, are under (bits[9:8] in 03<sub>HEX</sub>)</p>
0A <sub>HEX</sub>	15:0	0000 <sub>HEX</sub>	SOT_tcg[15:0]	<p>2<sup>nd</sup> order term applied to Tcg. – the respective MSBs, SOT_tcg[16] and sign, SOT_tcg_sign, are under (bits[11:10] in 03<sub>HEX</sub>)</p>
0B <sub>HEX</sub>	15:0	0000 <sub>HEX</sub>	SOT_bridge[15:0]	<p>2<sup>nd</sup> order term applied to the sensor bridge readout – the respective MSBs, SOT_bridge[16] and sign, SOT_bridge_sign are under (bits[13:12] in 03<sub>HEX</sub>)</p>
0C <sub>HEX</sub>	15:0	0000 <sub>HEX</sub> (7000 <sub>HEX</sub> )	Offset_T[15:0]	<p>Bits [15:0] of the temperature offset correction coefficient (the respective MSBs, Offset_T[16] and sign, Offset_T_sign, are under (bits[5:4] in 04<sub>HEX</sub>)</p> <p>[-1/16 to 15/16] = 7000<sub>HEX</sub> (default for volume)            [-2/16 to 14/16] = 6000<sub>HEX</sub>            [-3/16 to 13/16] = 5000<sub>HEX</sub>            [-4/16 to 12/16] = 4000<sub>HEX</sub>            [-5/16 to 11/16] = 3000<sub>HEX</sub>            [-6/16 to 10/16] = 2000<sub>HEX</sub>            [-7/16 to 9/16] = 1000<sub>HEX</sub>            [-8/16 to 8/16] = 0000<sub>HEX</sub> (default for prototypes)</p>

MTP Address	Word / Bit Range	Default Setting	Description	Notes / Explanations
0D <sub>HEX</sub>	15:0	0000 <sub>HEX</sub> (8000 <sub>HEX</sub> )	Gain_T[15:0]	Bits [15:0] of the absolute value of the temperature gain coefficient (default for prototypes: 0000 <sub>HEX</sub> ; default for volume production: 8000 <sub>HEX</sub> — the respective MSBs, Gain_T[16] and sign, Gain_T_sign, are under bits[1:0] in 04 <sub>HEX</sub> )
0E <sub>HEX</sub>	15:0	0000 <sub>HEX</sub>	SOT_T[15:0]	2 <sup>nd</sup> order term applied to the temperature reading – the respective MSBs, SOT_T[16] and sign, SOT_T_sign, are under (bits[3:2] in 04 <sub>HEX</sub> )
0F <sub>HEX</sub>	15:0	0000 <sub>HEX</sub>	T_SETL	Stores raw temperature reading at the temperature at which low calibration points were taken
<b>Measurement Configuration Register (<i>BM_config</i>)</b>				
10 <sub>HEX</sub>	1:0	00 <sub>BIN</sub>	Gain_stage1	Gain setting for the 1 <sup>st</sup> PREAMP stage with Gain_stage1: <ul style="list-style-type: none"> <li>• 00 ⇔ 12</li> <li>• 01 ⇔ 20</li> <li>• 10 ⇔ 30</li> <li>• 11 ⇔ 40</li> </ul>
	4:2	000 <sub>BIN</sub>	Gain_stage2	Gain setting for the 2 <sup>nd</sup> PREAMP stage with Gain_stage2: <ul style="list-style-type: none"> <li>• 000 ⇔ 1.1</li> <li>• 001 ⇔ 1.2</li> <li>• 010 ⇔ 1.3</li> <li>• 011 ⇔ 1.4</li> <li>• 100 ⇔ 1.5</li> <li>• 101 ⇔ 1.6</li> <li>• 110 ⇔ 1.7</li> <li>• 111 ⇔ 1.8</li> </ul>
	5	0 <sub>BIN</sub>	Gain_polarity	Set up the polarity of the sensor bridge's gain (inverting of the chopper) with <ul style="list-style-type: none"> <li>• 0 ⇔ positive (no polarity change)</li> <li>• 1 ⇔ negative (180° polarity change )</li> </ul>
	7:6	00 <sub>BIN</sub> (11 <sub>BIN</sub> )	Msb	Absolute number of bits for the MSB conversion in the ADC with Msb: <ul style="list-style-type: none"> <li>• 00 ⇔ 10-bit</li> <li>• 01 ⇔ 12-bit</li> <li>• 10 ⇔ 14-bit</li> <li>• 11 ⇔ 16-bit</li> </ul>

MTP Address	Word / Bit Range	Default Setting	Description	Notes / Explanations
	9:8	00 <sub>BIN</sub>	Lsb	Absolute number of bits for the MSB conversion in the ADC with Lsb: <ul style="list-style-type: none"> <li>• 00 ⇔ 0-bit (single stage CB_ADC)</li> <li>• 01 ⇔ 3-bit</li> <li>• 10 ⇔ 5-bit</li> <li>• 11 ⇔ 7-bit</li> </ul>
	12:10	000 <sub>BIN</sub>	A2D_Offset	ADC offset and resulting A2D input range [Vref] with A2D_Offset: <ul style="list-style-type: none"> <li>• 000 ⇔ 1/16 results in range [-1/16, 15/16]</li> <li>• 001 ⇔ 2/16 results in range [-2/16, 14/16]</li> <li>• 010 ⇔ 3/16 results in range [-3/16, 13/16]</li> <li>• 011 ⇔ 4/16 results in range [-4/16, 12/16]</li> <li>• 100 ⇔ 5/16 results in range [-5/16, 11/16]</li> <li>• 101 ⇔ 6/16 results in range [-6/16, 10/16]</li> <li>• 110 ⇔ 7/16 results in range [-7/16, 9/16]</li> <li>• 111 ⇔ 8/16 results in range [-8/16, 8/16]</li> </ul>
	14:13	00 <sub>BIN</sub>	Temp_ADC	Selection between fixed ADC segmentations for temperature measurements: <ul style="list-style-type: none"> <li>• 00 ⇔ setup according to IDT-reserved memory (recommended setup for best performance and speed trade-off)</li> <li>• 01 ⇔ MSB=16, LSB=0 (16-bit)</li> <li>• 10 ⇔ MSB=10, LSB=7 (16-bit)</li> <li>• 11 ⇔ MSB=12, LSB=5 (16-bit)</li> </ul>
	15	0 <sub>BIN</sub>	-	Reserved
11 <sub>HEX</sub>				Not assigned
12 <sub>HEX</sub>				Not assigned
13 <sub>HEX</sub>				Not assigned
14 <sub>HEX</sub>				Not assigned
15 <sub>HEX</sub>				Not assigned
16 <sub>HEX</sub>				Not assigned
17 <sub>HEX</sub>	15:0	-	ChecksumC	Generated (checksum) for user page through a linear feedback shift register (LFSR); signature is checked with power-up to ensure memory content integrity

### 3.7. Calibration Sequence

Calibration essentially involves collecting raw signal and temperature data from the sensor-IC system for different known bridge values and temperatures. This raw data can then be processed by the calibration master (assumed to be a PC), and the calculated calibration coefficients can then be written to MTP memory. Below is a brief overview of the steps involved in calibrating the ZSSC3016.

There are three main steps to calibration:

1. *Assigning a unique identification to the ZSSC3016.* This identification is written to shadow RAM and later programmed in MTP memory. This unique identification can be stored in the two 16-bit registers dedicated to customer ID. It can be used as an index into a database stored on the calibration PC. This database will contain all the raw values of bridge readings and temperature readings for that part, as well as the known bridge measurand conditions and temperature to which the bridge was exposed.
2. *Data collection.* Data collection involves getting uncorrected or raw data from the bridge at different known measurand values and temperatures. Then this data is stored on the calibration PC using the unique identification of the device as the index to the database.
3. *Coefficient calculation and storage in MTP memory.* After enough data points have been collected to calculate all the desired coefficients, the coefficients can be calculated by the calibrating PC and written to the shadow RAM. After that, MTP memory is programmed with the contents of the shadow RAM.
4. *Result.* The sensor signal and the characteristic temperature effect on output will be linearized according to the setup-dependent maximum output range.

It is essential to perform the calibration with a fixed programming setup during the data collection phase. In order to prevent any accidental misprocessing, it is further recommended to keep the MTP memory setup stable during the whole calibration process as well as in the subsequent operation. A ZSSC3016 calibration only fits the single setup used during its calibration. Changes of functional parameters after a successful calibration can decrease the precision and accuracy performance of the ZSSC3016 as well as of the whole application.

#### 3.7.1. Calibration Step 1 – Assigning Unique Identification

Assign a unique identification number to the ZSSC3016 by using the memory write command (40<sub>HEX</sub> + data and 41<sub>HEX</sub> + data; see Table 3.1 and Table 3.8) to write the identification number to Cust\_ID0 at memory address 00<sub>HEX</sub> and Cust\_ID1 at address 01<sub>HEX</sub> as described in section 3.6.1. These two 16-bit registers allow for more than 4 trillion unique devices.

#### 3.7.2. Calibration Step 2 – Data Collection

The number of unique points (measurand and/or temperature) at which calibration must be performed generally depends on the requirements of the application and the behavior of the resistive bridge in use. The minimum number of points required is equal to the number of bridge coefficients to be corrected with a minimum of three different temperatures at three different bridge values. For a full calibration resulting in values for all 7 possible bridge coefficients and 3 possible temperature coefficients, a minimum of 7 pairs of bridge with temperature measurements must be collected.

Within this minimum 3x3 measurements field, data must be collected for the specific value pairs (at known conditions) and then processed to calculate the coefficients. In order to obtain the potentially best and most robust coefficients, it is recommended that measurement pairs (temperature vs. pressure) be collected at the outer corners of the intended operation range or at least at points which are located far from each other. It is also essential to provide highly precise reference values as nominal, expected values. The measurement precision of the external calibration-measurement equipment should be ten times more accurate than the expected ZSSC3016 output precision after calibration in order to avoid precision losses caused by the nominal reference values (e.g., pressure signal and temperature deviations).

*Note: An appropriate selection of measurement pairs can significantly improve the overall system performance.*

The determination of the measurand-related coefficients will use all of the measurement pairs. For the temperature-related correction coefficients, 3 (at three different temperatures) of the e.g. 7 measurement pairs will be used.

*Note: There is an inherent redundancy in the 7 bridge-related and 3 temperature-related coefficients. Since the temperature is a necessary output (which also needs correction), the temperature-related information is mathematically separated, which supports faster and more efficient DSP calculations during the normal usage of the sensor-IC system.*

The recommended approach for data collection is to make use of the raw-measurement commands:

- For bridge sensor values:
  - $A2_{\text{HEX}} + 0000_{\text{HEX}}$ : Single bridge measurement for which the configuration register will be loaded from the BM\_Config register ( $10_{\text{HEX}}$  in MTP); preprogramming the measurement setup in the MTP is required.
  - $A3_{\text{HEX}} + \text{ssss}_{\text{HEX}}$ : Single bridge measurement for which the BM\_Config configuration register (Gain, ADC, Offset, etc.) will be loaded as  $\text{ssss}_{\text{HEX}}$  and must be provided externally via the interface.
- For temperature values
  - $A6_{\text{HEX}} + 0000_{\text{HEX}}$ : Single temperature measurement for which the configuration register will be loaded from an internal temperature configuration register (preprogrammed by IDT in MTP); preprogramming of the respective configuration is done by IDT prior to IC delivery. This is the recommended approach for temperature data collection.
  - $A7_{\text{HEX}} + \text{ssss}_{\text{HEX}}$ : Single temperature measurement for which the configuration register (Gain, ADC, Offset, etc.) will be loaded as  $\text{ssss}_{\text{HEX}}$  and must be provided externally via the interface. The data composition of the temperature configuration register is similar to the BM\_config (address  $10_{\text{HEX}}$ ) register for the bridge sensor.

### 3.7.3. Calibration Step 3 – Coefficient Calculations

The math to perform the coefficient calculation is complicated and will not be discussed in detail. There is a brief overview in the next section. IDT will provide software (DLLs) to perform the coefficient calculation (external to the sensor-IC system) based on auto-zero corrected values. After the coefficients are calculated, the final step is to write them to the MTP memory of the ZSSC3016.

### 3.8. The Calibration Math

#### 3.8.1. Bridge Signal Compensation

The saturation check in the ZSSC3016 is enhanced compared with older SSCs from IDT. Even saturation effects of the internal calculation steps are detected, even though the final correction output will still be determined. It is possible to get seemingly useful signal conditioning results which have seen an intermediate saturation during the calculations – these cases are detectable by observing the status bit[0] for each measurement result. Details about the saturation limits and the valid ranges for values are provided in the following equations.

*SOT\_curve* selects whether second-order equations compensate for sensor nonlinearity with a parabolic or S-shaped curve. The parabolic compensation is recommended.

The correction formula for the differential signal reading is represented as a two-step process depending on the *SOT\_curve* setting.

#### Equations for the parabolic *SOT\_curve* setting (*SOT\_curve* = 0):

*Simplified:*

$$\Delta T = T\_Raw - T_{SETL} \tag{5}$$

$$K_1 = 2^{15} + \frac{\Delta T}{2^{15}} \cdot \left( \frac{SOT\_tcg}{2^{15}} \cdot \Delta T + Tcg \right) \tag{6}$$

$$K_2 = Offset\_B + BR\_Raw + \frac{\Delta T}{2^{15}} \cdot \left( \frac{SOT\_tco}{2^{15}} \cdot \Delta T + Tco \right) \tag{7}$$

$$Z_{BP} = \frac{Gain\_B}{2^{15}} \cdot \frac{K_1}{2^{15}} \cdot K_2 + 2^{15} \quad \text{(delimited to positive number range)} \tag{8}$$

$$B = \frac{Z_{BP}}{2^{15}} \cdot \left( \frac{SOT\_bridge}{2^{15}} \cdot Z_{BP} + 2^{15} \right) \quad \text{(delimited to positive number range)} \tag{9}$$

*Complete:*

$$\Delta T = \left[ T\_Raw - T_{SETL} \right]_{-2^{17}}^{2^{17}-1} \tag{10}$$

$$K_1 = \left[ 2^{15} + \left[ \frac{\Delta T}{2^{15}} \cdot \left[ \left[ \frac{SOT\_tcg}{2^{15}} \cdot \Delta T \right]_{-2^{17}}^{2^{17}-1} + Tcg \right]_{-2^{17}}^{2^{17}-1} \right]_{-2^{17}}^{2^{17}-1} \right]_{-2^{17}}^{2^{17}-1} \tag{11}$$

$$K_2 = \left[ Offset\_B + \left[ BR\_Raw + \left[ \frac{\Delta T}{2^{15}} \cdot \left[ \left[ \frac{SOT\_tco}{2^{15}} \cdot \Delta T \right]_{-2^{17}}^{2^{17}-1} + Tco \right]_{-2^{17}}^{2^{17}-1} \right]_{-2^{17}}^{2^{17}-1} \right]_{-2^{17}}^{2^{17}-1} \right]_{-2^{17}}^{2^{17}-1} \tag{12}$$

$$Z_{BP} = \left[ \left[ \frac{Gain\_B}{2^{15}} \cdot \left[ \frac{K_1}{2^{15}} \cdot K_2 \right]_{-2^{17}}^{2^{17}-1} \right]_{-2^{17}}^{2^{17}-1} + 2^{15} \right]_0^{2^{16}-1} \quad (13)$$

$$B = \left[ \frac{Z_{BP}}{2^{15}} \cdot \left[ \left[ \frac{SOT\_bridge}{2^{15}} \cdot Z_{BP} \right]_{-2^{17}}^{2^{17}-1} + 2^{15} \right]_{-2^{17}}^{2^{17}-1} \right]_0^{2^{16}-1} \quad (14)$$

**Equations for the S-shaped SOT\_curve setting (SOT\_curve = 1):**

*Simplified:*

$$Z_{BS} = \frac{Gain\_B}{2^{15}} \cdot \frac{K_1}{2^{15}} \cdot K_2 \quad (15)$$

$$B = \frac{Z_{BS}}{2^{15}} \cdot \left( \frac{SOT\_bridge}{2^{15}} \cdot |Z_{BS}| + 2^{15} \right) \quad (\text{delimited to positive number range}) \quad (16)$$

*Complete:*

$$Z_{BS} = \left[ \frac{Gain\_B}{2^{15}} \cdot \left[ \frac{K_1}{2^{15}} \cdot K_2 \right]_{-2^{17}}^{2^{17}-1} \right]_{-2^{17}}^{2^{17}-1} \quad (17)$$

$$B = \left[ \frac{Z_{BS}}{2^{15}} \cdot \left[ \left[ \frac{SOT\_bridge}{2^{15}} \cdot |Z_{BS}| \right]_{-2^{17}}^{2^{17}-1} + 2^{15} \right]_{-2^{17}}^{2^{17}-1} + 2^{15} \right]_0^{2^{16}} \quad (18)$$

**Where**

- $B$  = Corrected bridge reading output via I<sup>2</sup>C™ or SPI; range [0<sub>HEX</sub> .. FFFF<sub>HEX</sub>];
- $BR\_Raw$  = Raw bridge reading from ADC after AZ correction; range [-1FFFF<sub>HEX</sub> .. 1FFFF<sub>HEX</sub>];
- $Gain\_B$  = Bridge gain term; range [-1FFFF<sub>HEX</sub> .. 1FFFF<sub>HEX</sub>];
- $Offset\_B$  = Bridge offset term; range [-1FFFF<sub>HEX</sub> .. 1FFFF<sub>HEX</sub>];
- $Tcg$  = Temperature coefficient gain term; range [-1FFFF<sub>HEX</sub> .. 1FFFF<sub>HEX</sub>];
- $Tco$  = Temperature coefficient offset term; range [-1FFFF<sub>HEX</sub> .. 1FFFF<sub>HEX</sub>];
- $T\_Raw$  = Raw temperature reading after AZ correction; range [-1FFFF<sub>HEX</sub> .. 1FFFF<sub>HEX</sub>];
- $T_{SETL}$  = T\_Raw reading at which low calibration was performed (e.g. 25°C); range [-FFFF<sub>HEX</sub> .. FFFF<sub>HEX</sub>];
- $SOT\_tcg$  = Second-order term for Tcg non-linearity; range [-1FFFF<sub>HEX</sub> .. 1FFFF<sub>HEX</sub>];
- $SOT\_tco$  = Second-order term for Tco non-linearity; range [-1FFFF<sub>HEX</sub> .. 1FFFF<sub>HEX</sub>];
- $SOT\_bridge$  = Second-order term for bridge non-linearity; range [-1FFFF<sub>HEX</sub> .. 1FFFF<sub>HEX</sub>];



$|\dots|$  = absolute value;

$[\dots]_{ll}^{ul}$  = bound/saturation number range from  $ll$  to  $ul$ , over/under-flow is reported as saturation in status byte.

### 3.8.2. Temperature Signal Compensation

Temperature is measured internally. Temperature correction contains both linear gain and offset terms as well as a second-order term to correct for any nonlinearities. For temperature, second-order compensation for nonlinearity is always parabolic. Again, the correction formula is best represented as a two-step process as follows:

*Simplified:*

$$Z_T = \frac{Gain\_T}{2^{15}} \cdot (T\_Raw + Offset\_T) + 2^{15} \quad (\text{delimited to positive number range}) \quad (19)$$

$$T = \frac{Z_T}{2^{15}} \cdot \left( \frac{SOT\_T}{2^{15}} \cdot Z_T + 2^{15} \right) \quad (\text{delimited to positive number range}) \quad (20)$$

*Complete:*

$$Z_T = \left[ \left[ \frac{Gain\_T}{2^{15}} \cdot [T\_Raw + Offset\_T]_{-2^{17}}^{2^{17}-1} \right]_{-2^{17}}^{2^{17}-1} + 2^{15} \right]_0^{2^{17}-1} \quad (21)$$

$$T = \left[ \frac{Z_T}{2^{15}} \cdot \left[ \left[ \frac{SOT\_T}{2^{15}} \cdot Z_T \right]_{-2^{17}}^{2^{17}-1} + 2^{15} \right]_{-2^{17}}^{2^{16}-1} \right]_0^{2^{16}-1} \quad (22)$$

#### Where

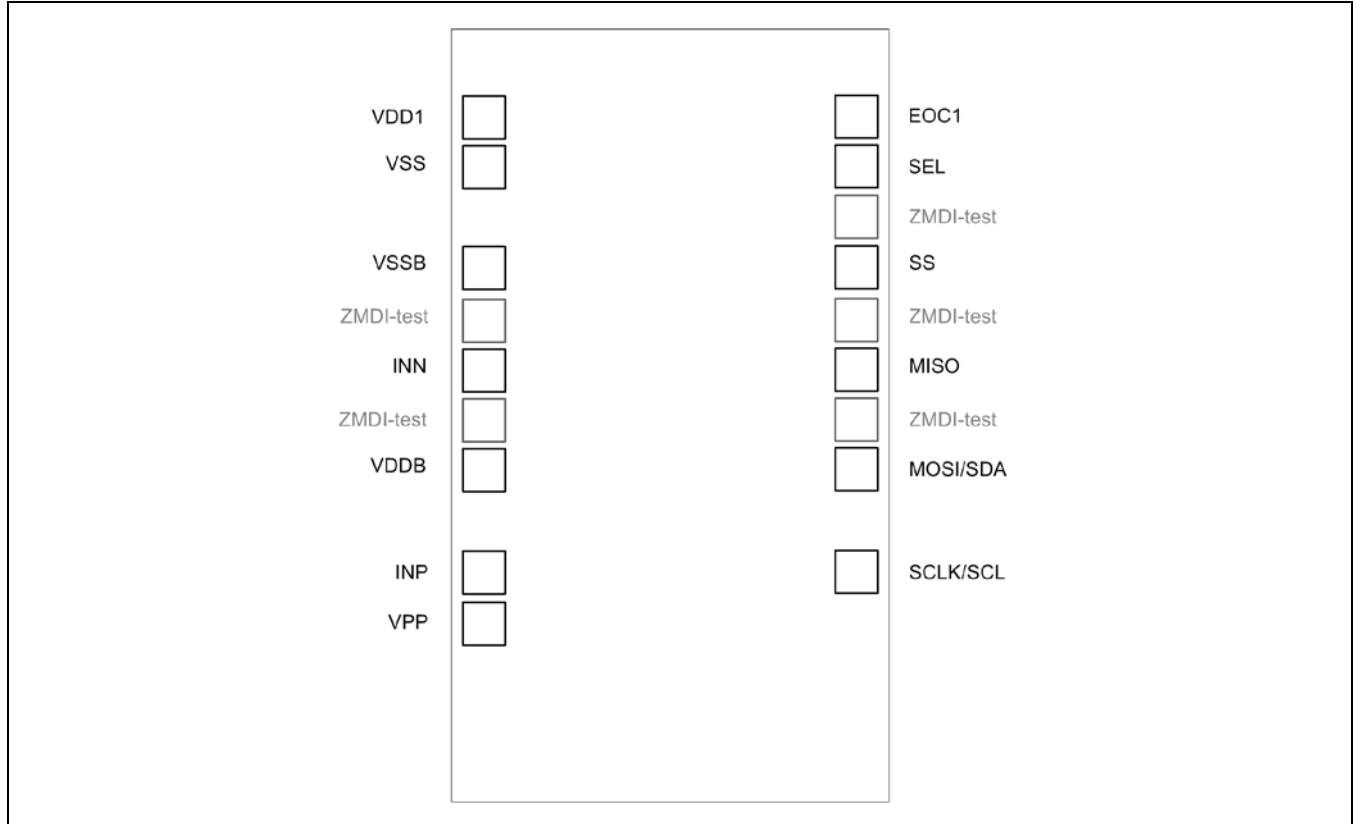
- $Gain\_T$  = Gain coefficient for temperature; range [-1FFFF<sub>HEX</sub> .. 1FFFF<sub>HEX</sub>];
- $T\_Raw$  = Raw temperature reading after AZ correction; range [-1FFFF<sub>HEX</sub> .. 1FFFF<sub>HEX</sub>];
- $Offset\_T$  = Offset coefficient for temperature; range [-1FFFF<sub>HEX</sub> .. 1FFFF<sub>HEX</sub>];
- $SOT\_T$  = Second-order term for temperature source non-linearity; range [-1FFFF<sub>HEX</sub> .. 1FFFF<sub>HEX</sub>]

## 4 Die Pad Assignments

The ZSSC3016 is available in die form. See Figure 4.1 for additional dimensions.

Note that the ZMDI-test pads are for IDT use only.

**Figure 4.1 ZSSC3016 Pad Assignments**



**Table 4.1 Pad Assignments**

Name	Direction	Type	Description
VDD1	IN	Supply	IC positive supply voltage for the IC, regular bond pad
VDD2			IC positive supply voltage for the IC, special pad (electrically connected to VDD1, also bondable)
VSS	IN	Supply	Ground reference voltage signal
VSSB	OUT	Analog	Negative bridge supply (bridge sensor ground)
VDDB	OUT	Analog	Positive bridge supply
INP	IN	Analog	Positive bridge signal
INN	IN	Analog	Negative bridge signal

Name	Direction	Type	Description
EOC1	OUT	Digital	End of conversion, regular bond pad
EOC2			End of conversion, special pad (electrically connected to EOC1, also bondable)
SEL	IN	Digital	I <sup>2</sup> C or SPI interface select
VPP	IN	Analog	Memory programming voltage
SCLK/SCL	IN	Digital	Clock input for I <sup>2</sup> C/SPI
MOSI/SDA	IN/Out	Digital	Data input for SPI; data in/out for I <sup>2</sup> C
MISO	OUT	Digital	Data output for SPI
SS	IN	Digital	Slave select for SPI

## 5 Quality and Reliability

The ZSSC3016 is available as “consumer” and “industrial” qualified IC version. For the consumer version, all data sheet parameters are guaranteed if not stated otherwise.

Additionally the MTP’s data retention capability (over ten years; see Table 1.4) is guaranteed for the industrial IC version.

## 6 Ordering Sales Codes

Ordering Examples	Description	Package
ZSSC3016CC1B	Temperature range: –40°C to +85°C, consumer-level parameters according to section 1 of the data sheet	Wafer (304µm) unsawn
ZSSC3016CI1B	Temperature range: –40°C to +85°C, industrial-level parameters according to section 1 of the data sheet, 10 years MTP data retention	Wafer (304µm) unsawn
ZSSC3016CI1D ES	Engineering samples, temperature range: –40°C to +85°C	Dice in waffle pack
ZSSC3016KIT	ZSSC3016 Evaluation Kit, including sample and modular evaluation board (Evaluation Software is downloadable from <a href="http://www.IDT.com/ZSSC3016">www.IDT.com/ZSSC3016</a> )	Kit

Contact IDT Sales for more information and additional package options.

## 7 Related Documents

Document
ZSSC3016 <i>Feature Sheet</i>
ZSSC3016 <i>Application Note — Application Circuits*</i>
ZSSC30x6 <i>Evaluation Kit Documentation</i>
ZSSC30x6 <i>Application Note — Calibration*</i>

Visit the ZSSC3016 product page [www.IDT.com/ZSSC3016](http://www.IDT.com/ZSSC3016) or contact your nearest sales office for ordering information or the latest version of these documents.

\* Documents marked with an asterisk (\*) require customer login.

## 8 Glossary

Term	Description
A2D	Analog-to-digital
ACK	Acknowledge (interface's protocol indicator for successful data/command transfer)
ADC	Analog-to-digital converter or conversion
AZ	Auto-Zero (unspecific)
AZS	Auto-Zero measurement for sensor bridge path
AZT	Auto-Zero Measurement for temperature path
CLK	Clock
DAC	Digital-to-analog conversion or converter
DF	Data Fetch (this is a command type)
DSP	Digital signal processor (digital configuration, calibration, calculation, communication unit)
FSO	Full scale output (value in percent relative to the ADC maximum output code; resolution dependent)
LSB	Least significant bit ("fine" portion of the converted signal)
LFSR	Linear Feedback Shift Register
MR	Measurement Request (this is a command type)
MSB	Most significant bit ("coarse" portion of the converted signal)
NACK	Not Acknowledge (interface's protocol indicator for unsuccessful data/command transfer)
POR	Power-on reset
PreAmp	Preamplifier
SM	Signal measurement
SOT	Second-order term
TC	Temperature coefficient (of a resistor or the equivalent bridge resistance)

Term	Description
TM	Temperature measurement

## 9 Document Revision History

Revision	Date	Description
1.00	December 07, 2011	First release.
1.01	January 10, 2012	Reset description added.
1.02	August 27, 2012	Temperature sensor description statement corrected, section 2.2, sensor adaption description added.
1.03	March 07, 2013	Sales information update.
1.04	August 27, 2014	Imagery for cover and header updated. Sales information updated. Minor edits for die information.
	January 25, 2016	Changed to IDT branding

## IMPORTANT NOTICE AND DISCLAIMER

RENESAS ELECTRONICS CORPORATION AND ITS SUBSIDIARIES (“RENESAS”) PROVIDES TECHNICAL SPECIFICATIONS AND RELIABILITY DATA (INCLUDING DATASHEETS), DESIGN RESOURCES (INCLUDING REFERENCE DESIGNS), APPLICATION OR OTHER DESIGN ADVICE, WEB TOOLS, SAFETY INFORMATION, AND OTHER RESOURCES “AS IS” AND WITH ALL FAULTS, AND DISCLAIMS ALL WARRANTIES, EXPRESS OR IMPLIED, INCLUDING, WITHOUT LIMITATION, ANY IMPLIED WARRANTIES OF MERCHANTABILITY, FITNESS FOR A PARTICULAR PURPOSE, OR NON-INFRINGEMENT OF THIRD PARTY INTELLECTUAL PROPERTY RIGHTS.

These resources are intended for developers skilled in the art designing with Renesas products. You are solely responsible for (1) selecting the appropriate products for your application, (2) designing, validating, and testing your application, and (3) ensuring your application meets applicable standards, and any other safety, security, or other requirements. These resources are subject to change without notice. Renesas grants you permission to use these resources only for development of an application that uses Renesas products. Other reproduction or use of these resources is strictly prohibited. No license is granted to any other Renesas intellectual property or to any third party intellectual property. Renesas disclaims responsibility for, and you will fully indemnify Renesas and its representatives against, any claims, damages, costs, losses, or liabilities arising out of your use of these resources. Renesas' products are provided only subject to Renesas' Terms and Conditions of Sale or other applicable terms agreed to in writing. No use of any Renesas resources expands or otherwise alters any applicable warranties or warranty disclaimers for these products.

(Disclaimer Rev.1.0 Mar 2020)

### Corporate Headquarters

TOYOSU FORESIA, 3-2-24 Toyosu,  
Koto-ku, Tokyo 135-0061, Japan  
[www.renesas.com](http://www.renesas.com)

### Contact Information

For further information on a product, technology, the most up-to-date version of a document, or your nearest sales office, please visit:  
[www.renesas.com/contact/](http://www.renesas.com/contact/)

### Trademarks

Renesas and the Renesas logo are trademarks of Renesas Electronics Corporation. All trademarks and registered trademarks are the property of their respective owners.