

LT6600-2.5, LTC6600-5,
 LT6600-10, LT6600-15 and LT6600-20
 Fully Differential 4th Order Lowpass Filter

DESCRIPTION

Demonstration circuit 962 features the LT6600-XX series of a fully differential 4th order lowpass filter approximating a Chebyshev frequency response. The cutoff frequencies (F_c) of LT6600-XX are: 2.5MHz, 5MHz, 10MHz, 15MHz and 20MHz (see Table 1). The LT6600-XX combines a lowpass filter with a fully differential amplifier for driving the differential input of an analog to Digital Converter (ADC). An LT6600-XX also provides the necessary level shifting to set its output common mode voltage to accommodate the reference voltage requirements of an ADC. An LT6600-XX filter IC requires only two external input resistors to set the filter's differential gain. A DC962 board contains an LT6600-XX lowpass filter configured with input resistors as a unity gain differential amplifier. Gains greater than

one require changing the input resistors to a lower value (refer to DC962 schematic).

Connection to the differential input and output of a DC962 is through SMA connectors. On board jumpers configure the DC962 for dual or single supply operation. The differential input of a DC962 is AC coupled and can be configured for DC coupling by shorting the input capacitors with zero ohms surface-mount resistor jumpers. In addition, the DC962 has surface-mount pads to add input passive components for input signal filtering and DC biasing.

Design files for this circuit board are available.

Call the LTC factory.

 , LTC and LT are registered trademarks of Linear Technology Corporation.

Figure 1. DC962A

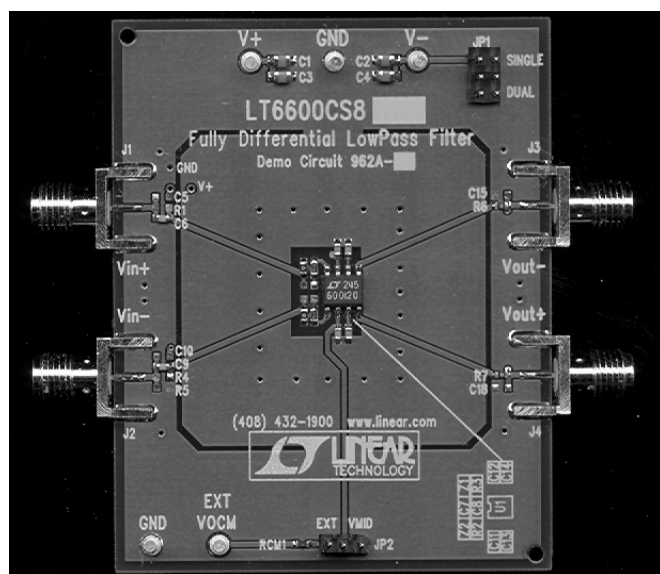
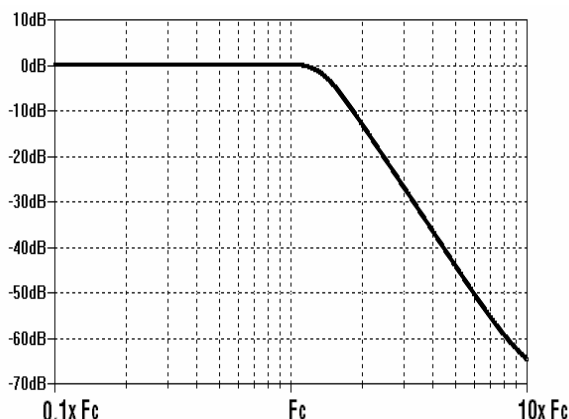

Table 1. The DC962 Assemblies

ASSEMBLY	U1
DC962A-A	LT6600-2.5, $F_c=2.5\text{MHz}$
DC962A-B	LT6600-5, $F_c=5\text{MHz}$
DC962A-C	LT6600-10, $F_c=10\text{MHz}$
DC962A-D	LT6600-15, $F_c=15\text{MHz}$
DC962A-E	LT6600-20, $F_c=20\text{MHz}$

Figure 2. LT6600-X Amplitude Response (Gain=1)



QUICK TEST PROCEDURE

Figure 3. Single-Ended Input To Differential Output Quick Test Set-Up

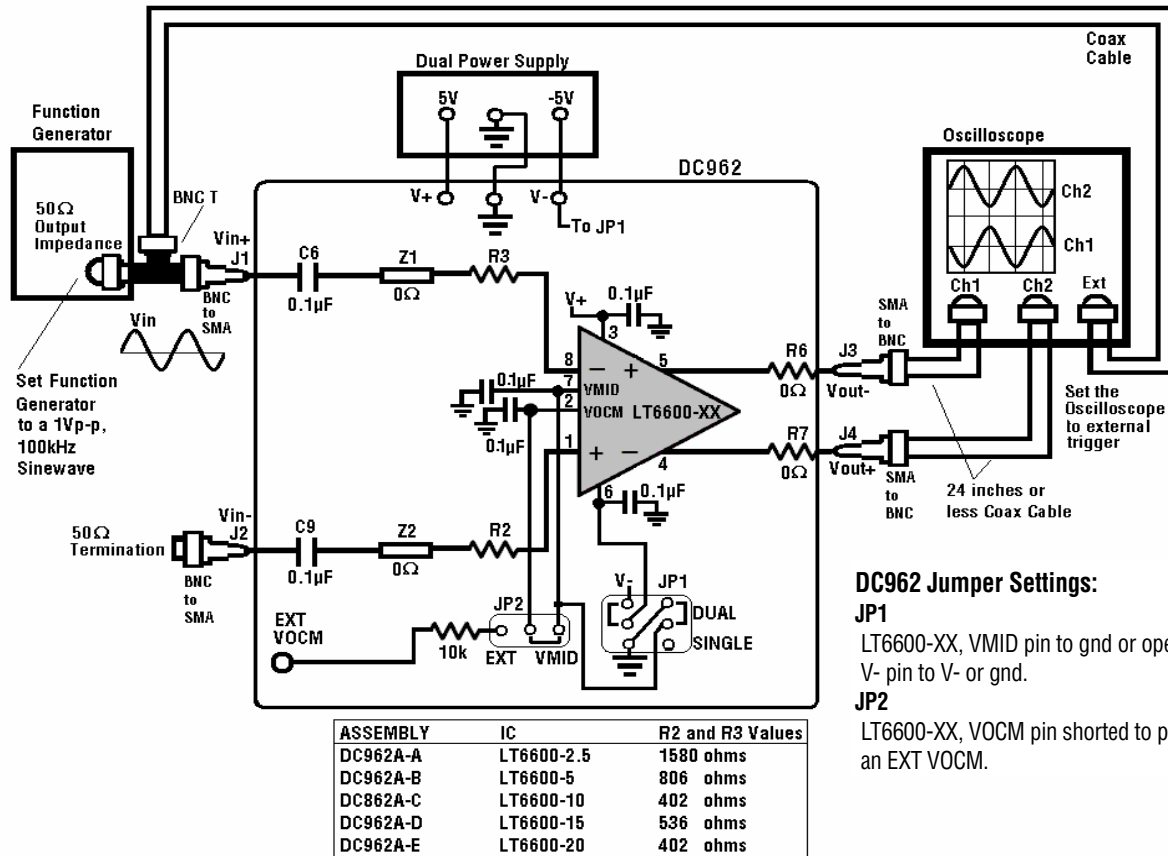

A. Single-Ended Input To Differential Output

1. Connect to a DC962 a dual power supply, a function generator and an oscilloscope as shown in Figure 3 (JP1 to DUAL and JP2 to MID).

Note 1: The 50Ω termination on J2 input is used to balance the 50Ω generator impedance on J1 input. The additional 50Ω input impedance is in series with the input resistors of the LT6600-XX (R2 and R3) therefore the single-ended to differential gain is less than one. Example: the feedback resistors in the LT6600-10 or -20 are 402Ω (see Figure 6) and for gain equal to one, the input resistors should be also 402Ω. However, in Figure 3, 50Ω is in series with the 402Ω input resistors and the gain is $[402/(402+50)]$ which equals to 0.8894.

2. Set the function generator for a 1Vp-p, 100 kHz sine-wave and turn-on the power supply.

3. The channel 2 input of the oscilloscope is in phase with the DC962 input and the channel 1 input is 180 degrees out of phase with the DC962 input. The single-ended output shown on channel 1 or 2, is a 0.5Vp-p sine-wave (a 1Vp-p differential output).

Note 2: The LT6600-XX can directly drive at least a 50pF capacitive load at each output. However an LT6600-XX can drive directly a low frequency sine-wave (100 kHz or less) into a capacitive load of up to 100pF. In this “Quick Test” procedure, the output signal is a sine-wave and each LT6600-XX output drives the capacitance of a 24 inch or less cable plus the input capacitance of the oscilloscope input, a capacitive load of 70pF (30pF per foot for the coax cable and 10pF for the oscilloscope input). For testing the transient response of an LT6600-XX to a squarewave, use a 10x low capacitance oscilloscope probe to monitor the DC962 output at J3 or J4.

C. Driving the Analog Inputs of an ADC

When using a DC962 to drive the differential input of an ADC (analog-to-digital converter), the boards output resistors R6 and R7 and capacitors C15, C17 and C18 should be configured to the values required for the ADC input. Figure 5 shows the optimum values for the DC962 output components when driving an ADC.

LTC2227, LTC2228 and LTC2229 is a 12-bit 40Msps, 65Msps and 80Msps ADC respectively and LTC2247, LTC2248 and LTC2249 is a 14-bit 40Msps, 65Msps and 80Msps ADC respectively.

Figure 5. DC962 Output Component Values

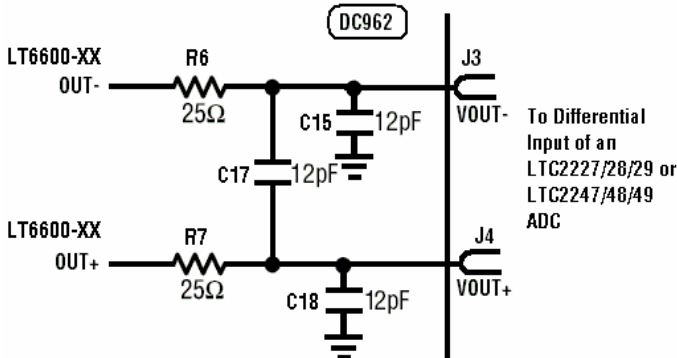
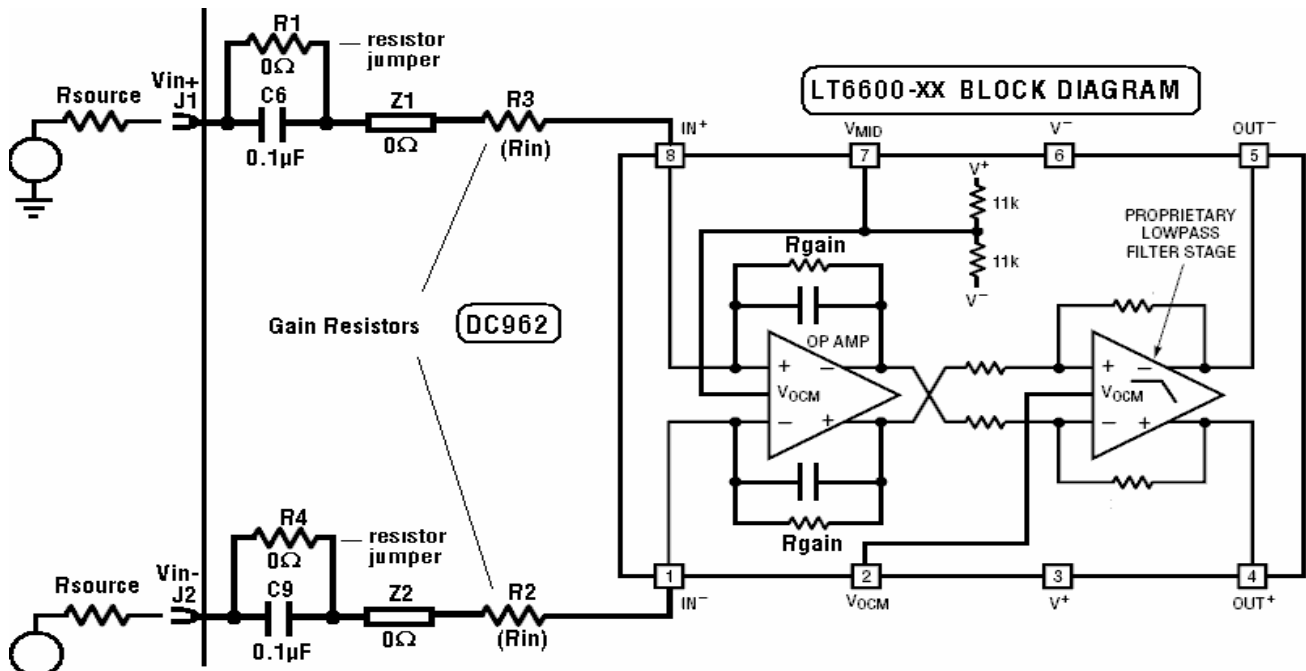

Figure 6. Setting the DC962 Differential Gain with the Input Resistors (dual or single supply operation).



IF Rsource = 0 (or < 1) THEN

$$\text{Differential Gain} = \frac{V_{out+} - V_{out-}}{V_{in+} - V_{in-}} = \frac{R_{gain}}{R_{in}}$$

$$R2 = R3 = R_{in}$$

ASSEMBLY	IC	Rgain
DC962A-A	LT6600-2.5	1580 ohms
DC962A-B	LT6600-5	806 ohms
DC862A-C	LT6600-10	402 ohms
DC962A-D	LT6600-15	536 ohms
DC962A-E	LT6600-20	402 ohms

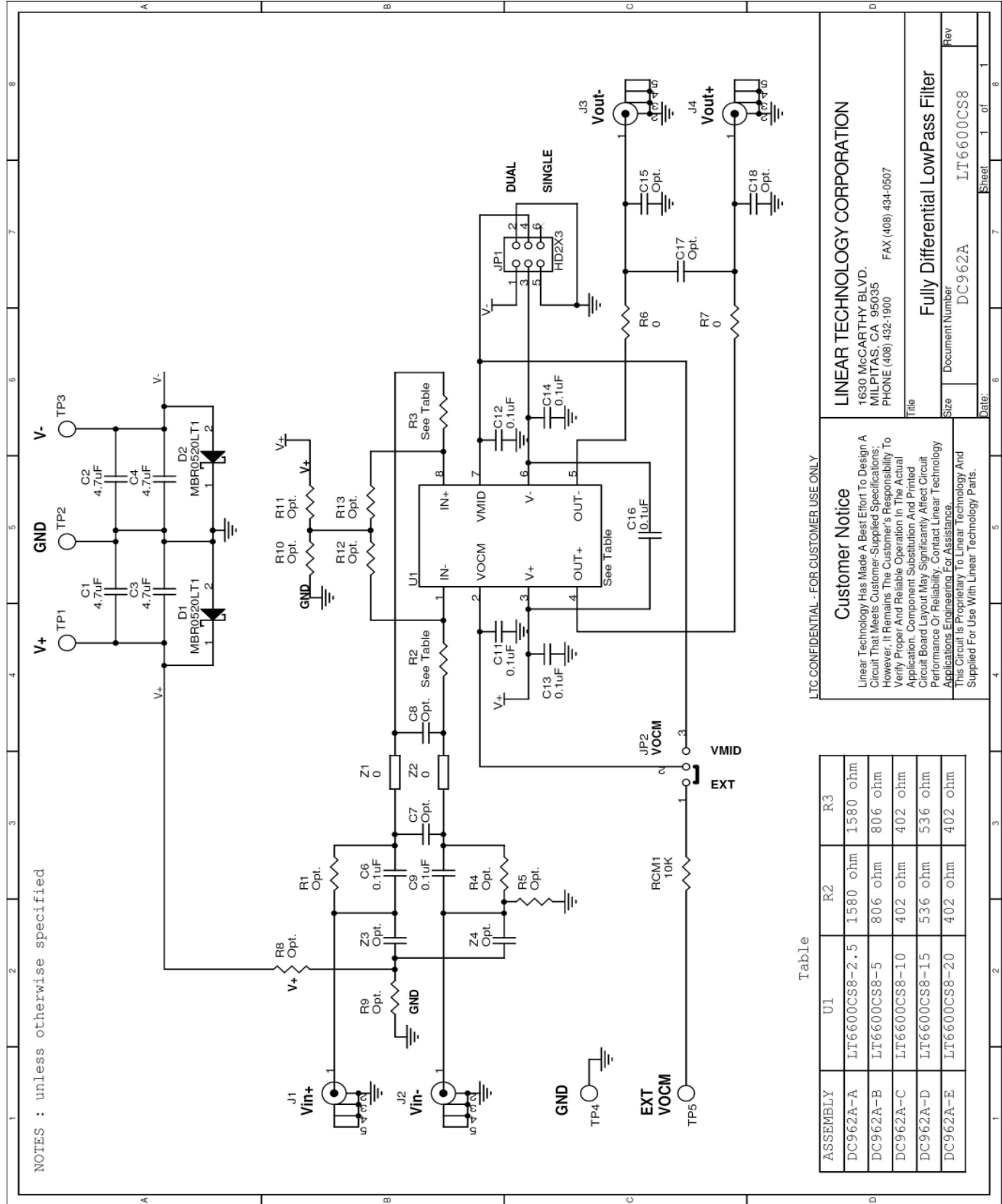

LTC CONFIDENTIAL - FOR CUSTOMER USE ONLY

Customer Notice

Linear Technology Has Made A Best Effort To Design A Circuit That Meets Customer-Supplied Specifications. However, It Remains The Customer's Responsibility To Verify Proper And Reliable Operation In The Actual Application. Component Substitution And Printed Circuit Board Layout May Significantly Affect Circuit Performance Or Reliability. Contact Linear Technology Applications Engineering For Assistance. This Circuit Is Proprietary To Linear Technology And Supplied For Use With Linear Technology Parts.

LINEAR TECHNOLOGY CORPORATION

1630 McCARTHY BLVD.
MILPITAS, CA 95035
PHONE (408) 432-1900 FAX (408) 434-0507

Fully Differential LowPass Filter

Size	Document Number	Rev
	DC962A	LT6600CS8
Date:	Sheet	1 of 8