

REVISIONS					
REV	ECO	DESCRIPTION	DATE	BY	APPR
A1	-	RELEASED DRAWING	DEC-12-2019	BLINK	TOMMY
A2	-	ADD MARK GROOVE	APR-20-2020	BLINK	TOMMY

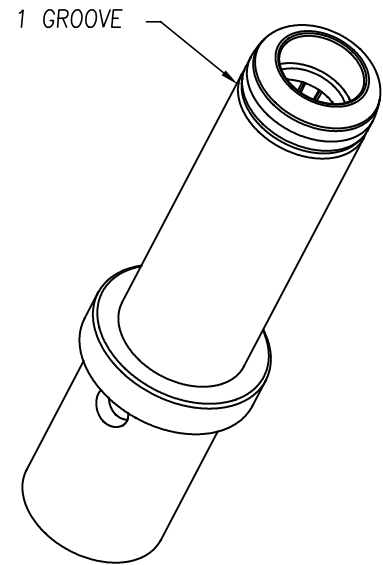
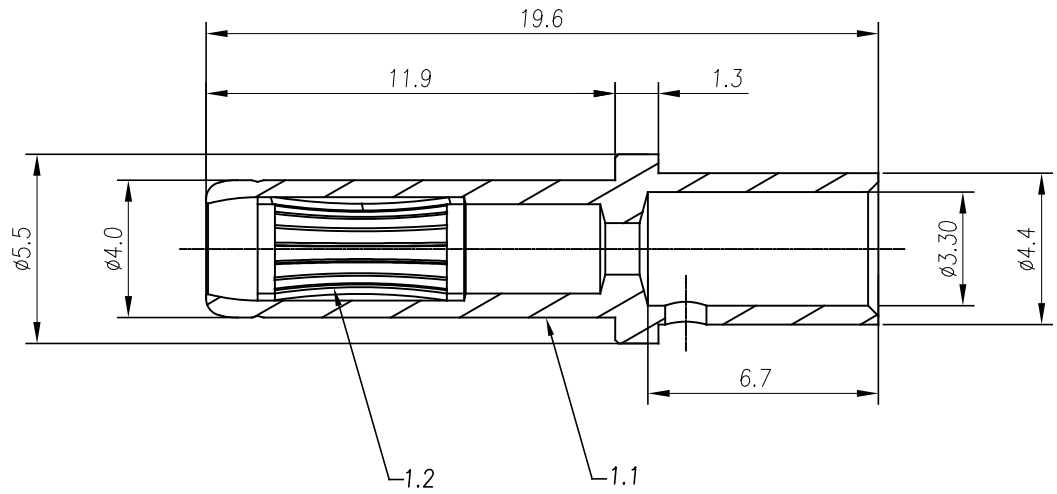

- NOTES: (UNLESS OTHERWISE SPECIFIED)
- MATERIAL:
 - CONTACT BODY: COPPER ALLOY, SILVER PLATED.
 - CROWN SRPRING CONTACT: COPPER ALLOY, GOLD FLASH.
 - SPECIFICATIONS:
 - CURRENT RATING: 32A(MAX).
 - TERMINATION TYPE: CRIMPING.
 - WIRE RANGE: 10~12AWG .
 - RoHS COMPLIANT.
 - ALL DIMENSIONS ARE FOR REFERENCE USE ONLY.

TITLE: 2.4MM FEMALE SURESOCKET™
 DWG NO: SC000612
 REV: A2
 SH: 1
 OF: 1

QUANTITY	PART NUMBER	DESCRIPTION	ITEM
MATERIALS LIST			
UNLESS OTHERWISE SPECIFIED 1) All dimensions are in metric(mm). 2) Tolerances are as follows: 1 PL DEC ±0.30 Fractions ±1/64 2 PL DEC ±0.15 Angles ±1° 3 PL DEC ±0.08 3) Note reference =		Amphenol Sine Systems - www.amphenol-sine.com 44724 Morley Drive Clinton Township, MI 48036	
SIGNATURES DATE DRAWN: BLINK MAR-18-2020 CHECKED: ORION MAR-20-2020 ENGINEER: APPROVAL: TOMMY MAR-23-2020		CUSTOMER: THIS DRAWING IS SUPPLIED FOR INFORMATION ONLY. DESIGN FEATURES, SPECIFICATIONS AND PERFORMANCE DATA SHOWN HEREON ARE THE PROPERTY OF THE AMPHENOL CORPORATION. NO RIGHTS OF REPRODUCTION ARE IMPLIED. ALL DIMENSIONS ARE SUBJECT TO NORMAL MANUFACTURING VARIATIONS.	
MATERIAL SPECIFICATIONS:		SIZE: B TYPE: C- DWG NO: SC000612 REVISION: A2	
PROCESS SPECIFICATIONS:		SCALE: NONE SHEET 1 OF 1	
NEXT ASSY:			