



SIGN	DATE	DESCRIPTION	APPROVER
△	9/17'10	How to older is changed	Runner
△	05/27'11	Voltage rating is changed from 160 V to 300 V	Steven
△	05/27'11	Withstanding Voltage is changed from 1.32 Kv to 1.6 Kv	Steven
△	05/27'11	Add "cULus" Safety Approval logo	Steven

THIS IS CAD DRAWING, DO NOT REVISE MANUALLY!!!

Material:

- Item ① Terminal housing: PA66 30% GF (UL94V-0)
- Item ② Contact pin : Copper Tin plated

Electrical:

- Voltage rating: 300V
- Current rating: 5.5A
- Withstanding Voltage: 1.6 KV
- Operating temperature: -40°C to +115°C
- Soldering temperature: 250°C ±10°C/5 Sec
- Safety Approval: 
- Critical dimension: 

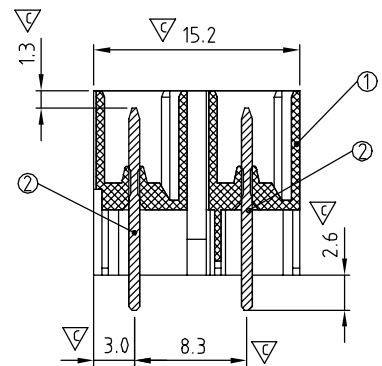
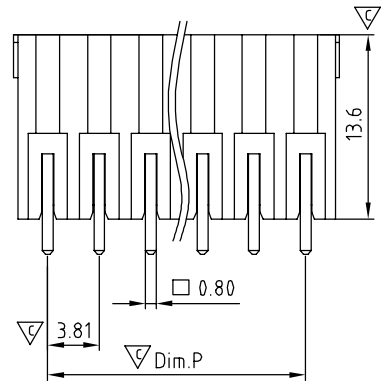
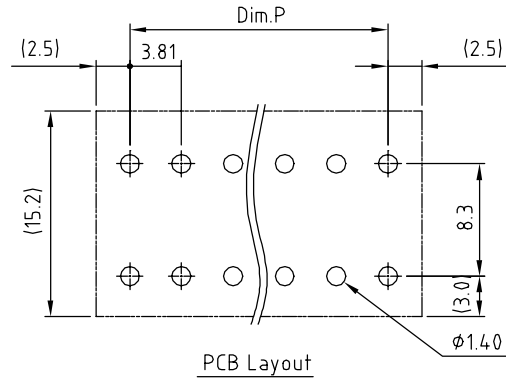
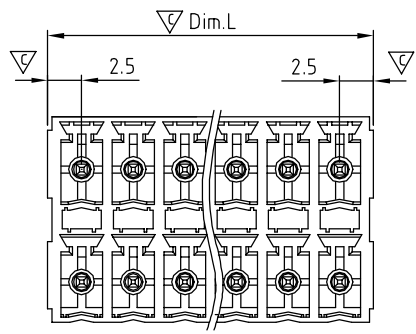

KE xx 3 1 x 0 xxxx G

- No. OF POLES
- 04: 2x2 POLES
 - 06: 2x3 POLES
 - ...
 - 48: 2x24 POLES

COLOR

- 0 Black (RAL9005)
- 2 Red (RAL3001/D)
- 3 Orange(RAL2011/P)
- 4 Yellow(RAL1018/A)
- 5 Green(RAL6018/T)
- 6 Blue (RAL5015/A)
- 8 Grey(RAL7035/D)

- G: Pb<40000ppm
- A00 0: "@" Mark
- △ A00 A: "ANYTEK" Mark
- Any special item by customer request. please contact sales department.

DIMENSION

Dim.L	$(N/2-1) \times 3.81+5.0$
Dim.P	$(N/2-1) \times 3.81$

N = Number of poles

	TOL		
	2x2P-2x5P	2x6P-2x16P	2x17P-2x24P
Dim.L	±0.20	±0.30	±0.40
Dim.P	±0.15	±0.25	±0.30

ANYTEK				CUSTOMER COPY			
ALL RIGHTS RESERVED. REPRODUCTION OR ISSUE TO THIRD PARTIES IN ANY FORM WHATSOEVER IS NOT PERMITTED WITHOUT WRITTEN AUTHORITY FROM THE PROPRIETOR. PROPERTY OF ANYTEK TECHNOLOGY CO., LTD							
TITLE		KE 3.81mm W/o Flange Series (Vertical) DIP type					
PART NO.		KExx31x0xxxxG			DWG NO.		8KE0310
APPROVED		CHECKED	DESIGNED	DRAWN	CUST NO.		Tolerance
			Steven 2011.05.27	Runner 2010.04.12			X. ±0.50 X.X ±0.30 X.XX ±0.10 X° ±1°
						UNIT: mm	
				SHEET: 01/01		SCALE: NONE	
						REV.: D	