

REVISONS		DATE	DN	APVD
C5	ECR-08-020743	18-03-09	AEG	MKO
C6	ECR-10-003044	02JUN10	RK	MKO
C7	ECR-10-026542	28MAY11	KK	HMR

SOLDER TERMINATIONS		TERMINATION STYLES	
(L = 2,9, 3,7, 4,5 AND 6,0 mm)		L	CODE
	SOLDER	2,9±0,3	01
		3,7±0,3	05
		4,5±0,3	02
	WIRE WRAP	6,3±0,3	03
		7,3±0,3	04
	SOLDERING-HOOKS	13±0,5	40
		5,5±0,3	30
	SOLDERING-LUGS	10±0,5	35
		5,5±0,3	35
	SOLDER-BANDED OFF	3-0,4	10
		1,55-0,4	00

TERMINATION WITH GALVANIC SN PLATING

BURRHEIT MAX. 0,02
RADIUS OF EDGES MAX. 0,05

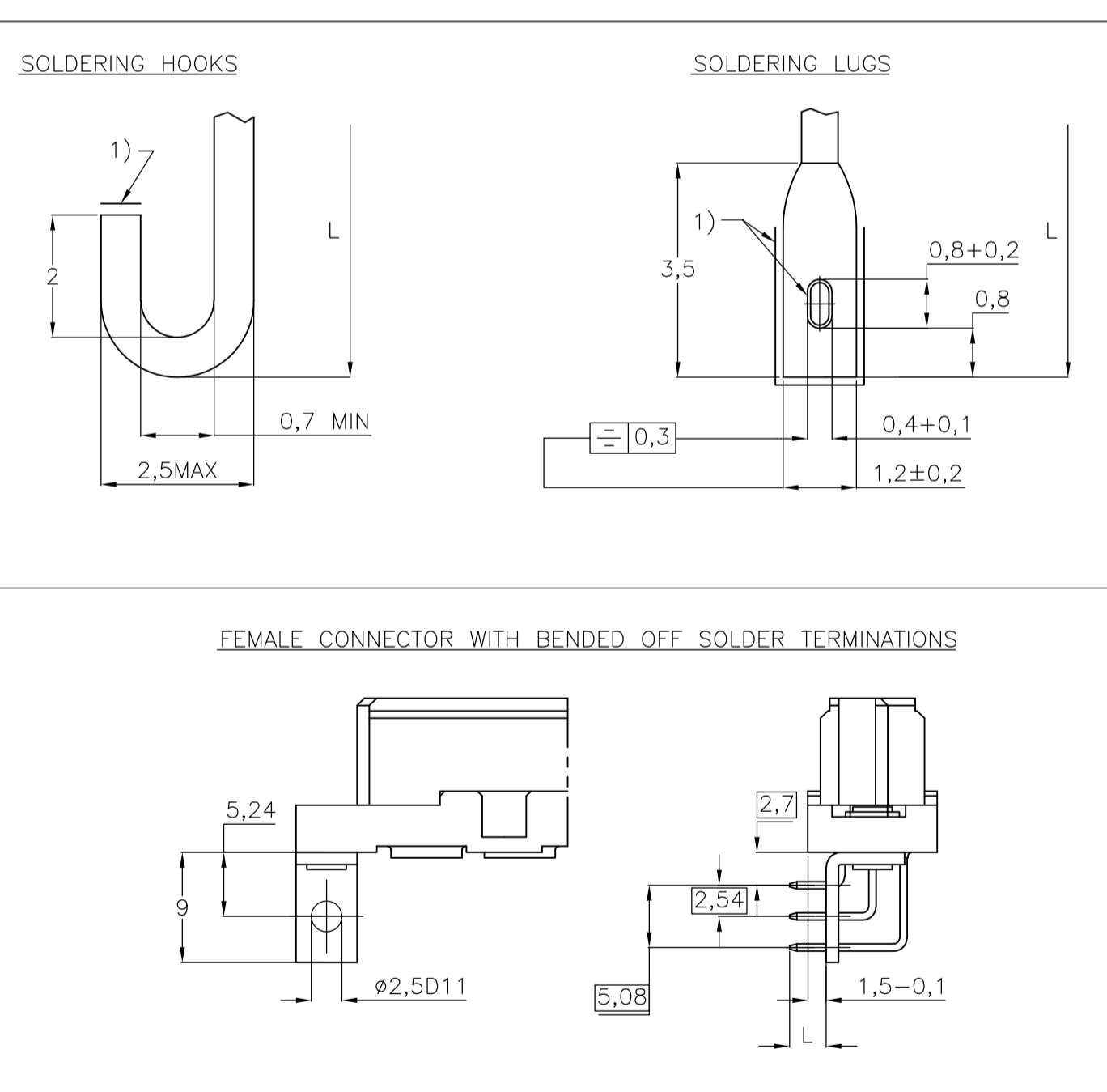
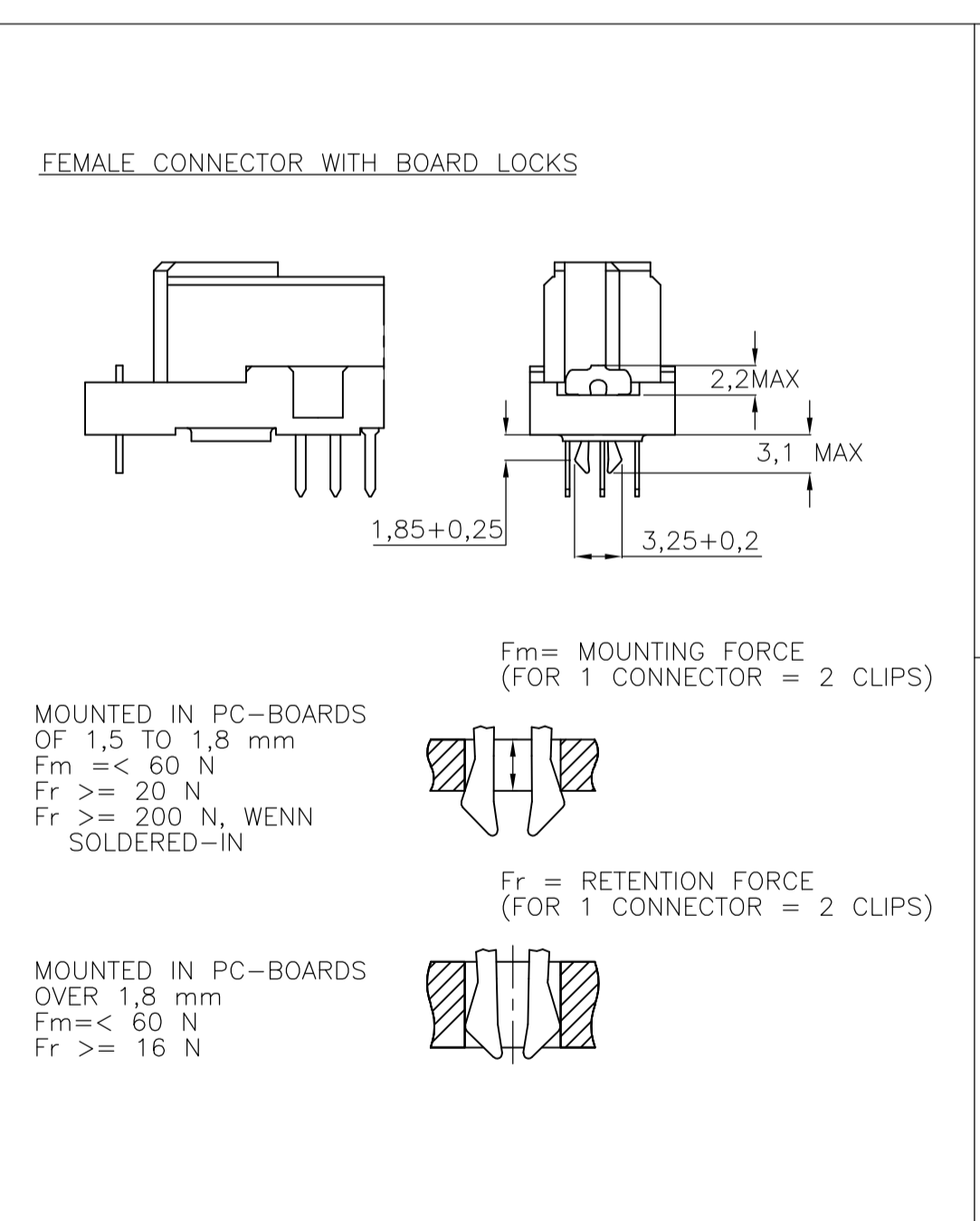
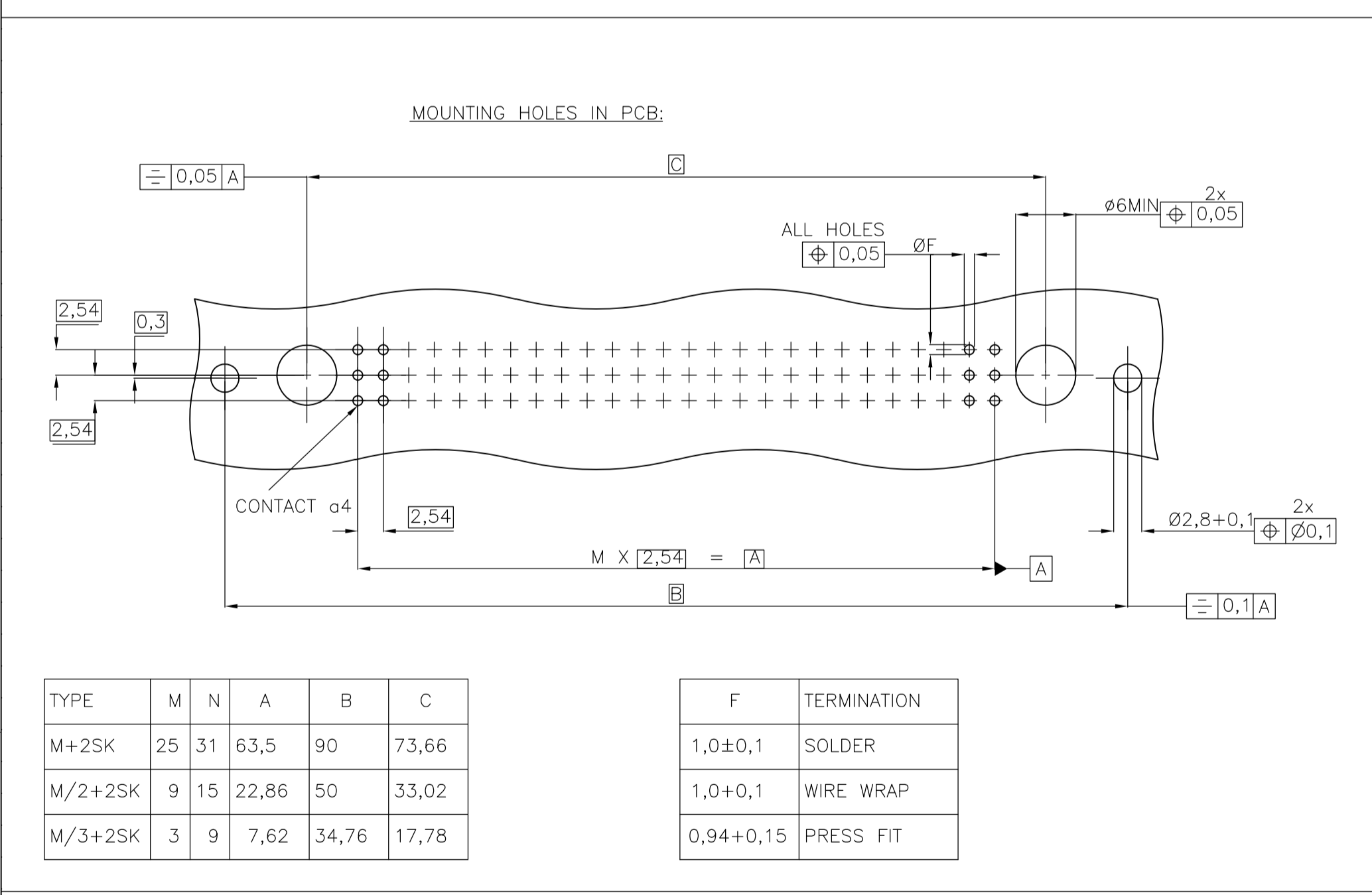

CONTACT : DIMENSIONS, PLATING AND MATERIAL

SOLDER

WIRE WRAP

MATERIAL: COPPER ALLOY

PERFORMANCE LEVEL	PLATING THICKNESS IN REFERENCE AREA	
	NOBLE METALS	CODE
CLASS I	Pd + Au or Au	1
	Au	4
CLASS II	Pd + Au or Au	2
	Au	5
CLASS III	Pd + Au or Au	3

NICKEL UNDERLAYER
PROTECTION FILM; HF-GREASE

1) CUTTING EDGES NOT PLATED

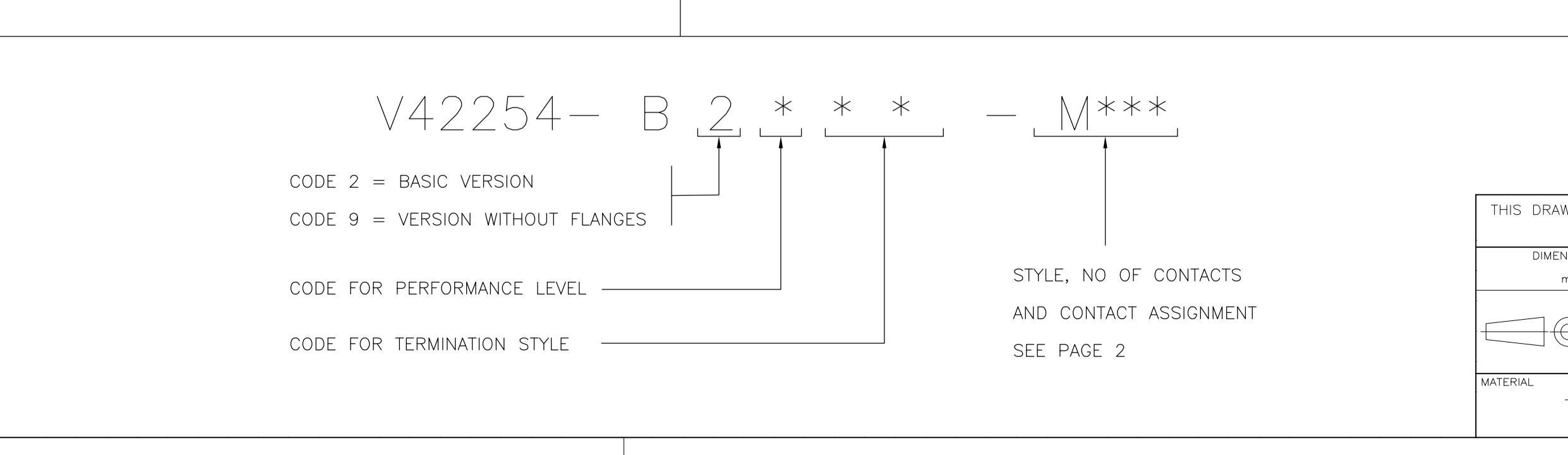
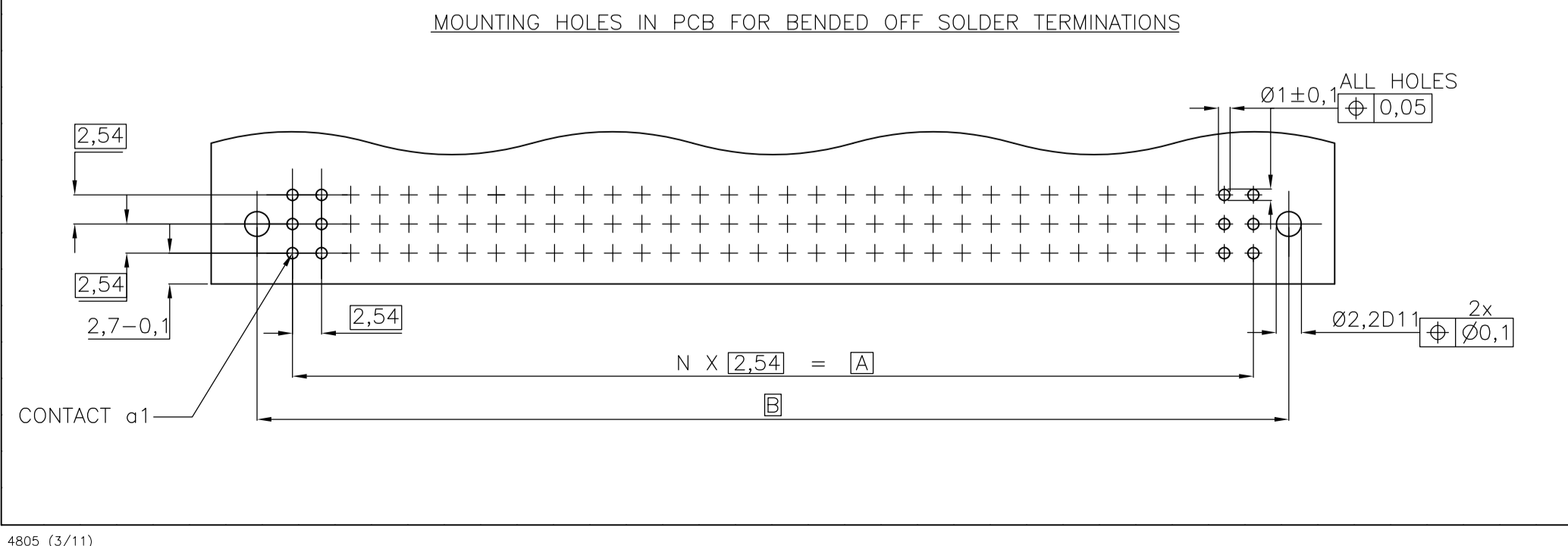

THIS DRAWING IS A CONTROLLED DOCUMENT.

DIN VANBESIEDEN 18OCT89

TE Connectivity

RECEPTACLE ASSEMBLY EUROCARD
TYPE M+2 SPECIAL CONTACTS AND SHORT VERSIONS
(PN: V42254-B2***-M7***-7626)

SIZE A1
SCALE NTS
SHEET 1 OF 2
REV C7

PRODUCT DESCRIPTION CODE	TE PN	STYLE & NUMBER OF POSITIONS	TERMINATION POSTS	LOADED ROWS	PERFORMANCE LEVEL	BOARD LOCKS
V42254-B2102-M780	3-1393640-1	M78+2	4,5mm STRAIGHT SOLDER LEADS	EVERY ROW , EVERY PITCH	1	NO
V42254-B2102-M980	3-1393640-2	M12+2	4,5mm STRAIGHT SOLDER LEADS	EVERY ROW , EVERY PITCH	1	NO
V42254-B2110-M780	4-1393640-5	M78+2	RIGHT-ANGLE SOLDER LEADS WITH MOUNTING BRACKET	EVERY ROW , EVERY PITCH	1	NO
V42254-B2135-M780	5-1393640-6	M78+2	5,5/10 mm SOLDER LUGS	EVERY ROW , EVERY PITCH	1	NO
V42254-B2201-M300	9-1393640-8	M30+2	2,9mm STRAIGHT SOLDER LEADS	EVERY ROW , EVERY PITCH	2	NO
V42254-B2201-M710	1-1392009-9	M78+2	2,9mm STRAIGHT SOLDER LEADS	EVERY ROW , EVERY PITCH	2	YES
V42254-B2201-M713	1393641-5	M78+2	2,9mm STRAIGHT SOLDER LEADS	ROW A+C , EVERY PITCH	2	YES
V42254-B2201-M780	1393641-6	M78+2	2,9mm STRAIGHT SOLDER LEADS	EVERY ROW , EVERY PITCH	2	NO
V42254-B2201-M783B	1393641-8	M78+2	2,9mm STRAIGHT SOLDER LEADS	ROW A+C , EVERY PITCH	2	NO
V42254-B2201-M980	1393641-9	M12+2	2,9mm STRAIGHT SOLDER LEADS	EVERY ROW , EVERY PITCH	2	NO
V42254-B2202-M300	4-1393641-3	M30+2	4,5mm STRAIGHT SOLDER LEADS	EVERY ROW , EVERY PITCH	2	NO
V42254-B2202-M780	5-1393641-1	M78+2	4,5mm STRAIGHT SOLDER LEADS	EVERY ROW , EVERY PITCH	2	NO
V42254-B2202-M780B	5-1393641-2	M78+2	4,5mm STRAIGHT SOLDER LEADS	EVERY ROW , EVERY PITCH	2	NO
V42254-B2202-M780N	5-1393641-3	M78+2	4,5mm STRAIGHT SOLDER LEADS	EVERY ROW , EVERY PITCH	2	NO
V42254-B2202-M783	5-1393641-4	M78+2	4,5mm STRAIGHT SOLDER LEADS	ROW A+C , EVERY PITCH	2	NO
V42254-B2202-M783B	5-1393641-5	M78+2	4,5mm STRAIGHT SOLDER LEADS	ROW A+C , EVERY PITCH	2	NO
V42254-B2202-M980	5-1393641-6	M12+2	4,5mm STRAIGHT SOLDER LEADS	EVERY ROW , EVERY PITCH	2	NO
V42254-B2203-M780	6-1393641-4	M78+2	6,3mm STRAIGHT SOLDER LEADS	EVERY ROW , EVERY PITCH	2	NO
V42254-B2203-M913	6-1393641-5	M12+2	6,3mm STRAIGHT SOLDER LEADS	ROW A+C , EVERY PITCH	2	YES
V42254-B2203-M983	6-1393641-6	M12+2	6,3mm STRAIGHT SOLDER LEADS	ROW A+C , EVERY PITCH	2	NO
V42254-B2210-M300	8-1393641-0	M30+2	RIGHT-ANGLE SOLDER LEADS WITH MOUNTING BRACKET	EVERY ROW , EVERY PITCH	2	NO
V42254-B2210-M780	8-1393641-2	M78+2	RIGHT-ANGLE SOLDER LEADS WITH MOUNTING BRACKET	EVERY ROW , EVERY PITCH	2	NO
V42254-B2240-M300	2-1393642-4	M30+2	13mm STRAIGHT WIRE-WRAP PINS	EVERY ROW , EVERY PITCH	2	NO
V42254-B2240-M780	2-1393642-8	M78+2	13mm STRAIGHT WIRE-WRAP PINS	EVERY ROW , EVERY PITCH	2	NO
V42254-B2240-M783B	3-1393642-0	M78+2	13mm STRAIGHT WIRE-WRAP PINS	ROW A+C , EVERY PITCH	2	NO
V42254-B2240-M980	3-1393642-1	M12+2	13mm STRAIGHT WIRE-WRAP PINS	EVERY ROW , EVERY PITCH	2	NO



OBSOLETE

SUPERSEDED BY 8-1393641-2

OBSOLETE

OBSOLETE

2) ACCORDING TO BT 236 LEVEL 2.
 1) NO COMPANY NAME MARKED ON THE CONNECTOR
 CONTACT TYCO ELECTRONICS FOR OTHER CONFIGURATION AVAILABILITY

THIS DRAWING IS A CONTROLLED DOCUMENT.		DIN	180CT89	 TE Connectivity	
DIMENSIONS: mm		CHK	-	NAME	
 0 PLC ± - 1 PLC ± - 2 PLC ± - 3 PLC ± - 4 PLC ± - ANGLES ± -		APVD	-	PRODUCT SPEC	
MATERIAL		FINISH	-	APPLICATION SPEC	
WEIGHT		SIZE	A1	RESTRICTED TO	
CUSTOMER DRAWING		SCALE	NTS	SHEET 2 OF 2 REV C7	