

P	LTR	DESCRIPTION	DATE	DWN	APVD
C1		REVISED PER ECR-17-017609	04DEC2017	JB	DZ
C2		ECO-19-006934	13MAY2019	AP	WS
C3		REVISED PER ECN-23-206968	12APR2023	WLS	VS

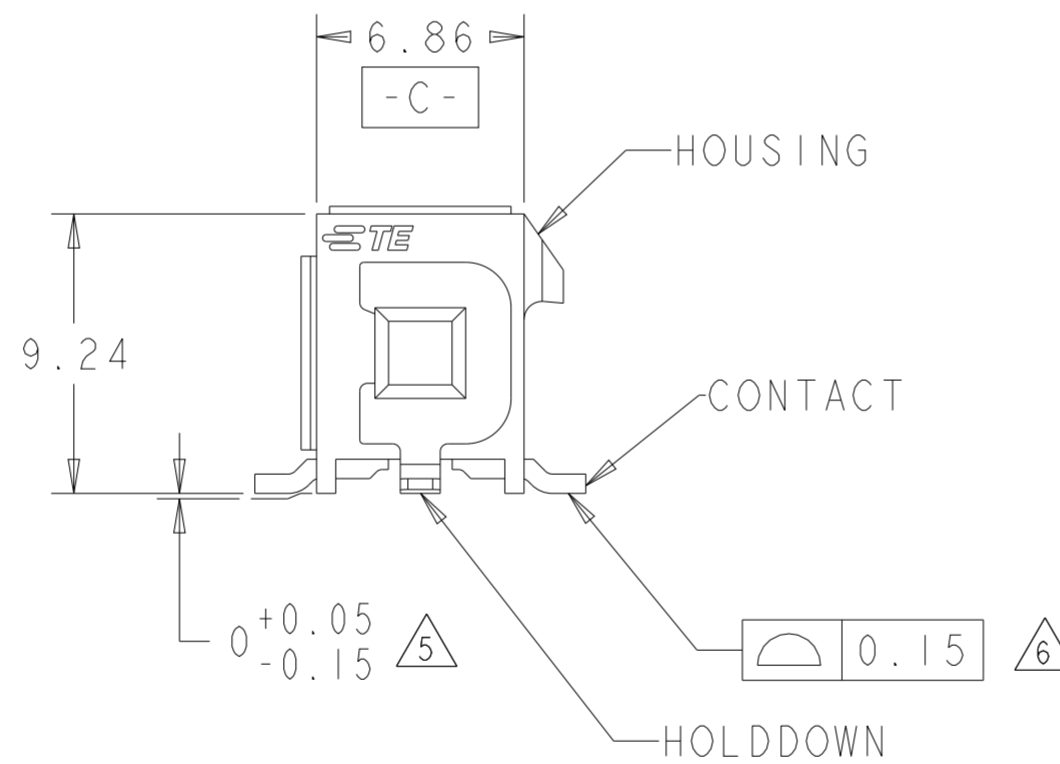
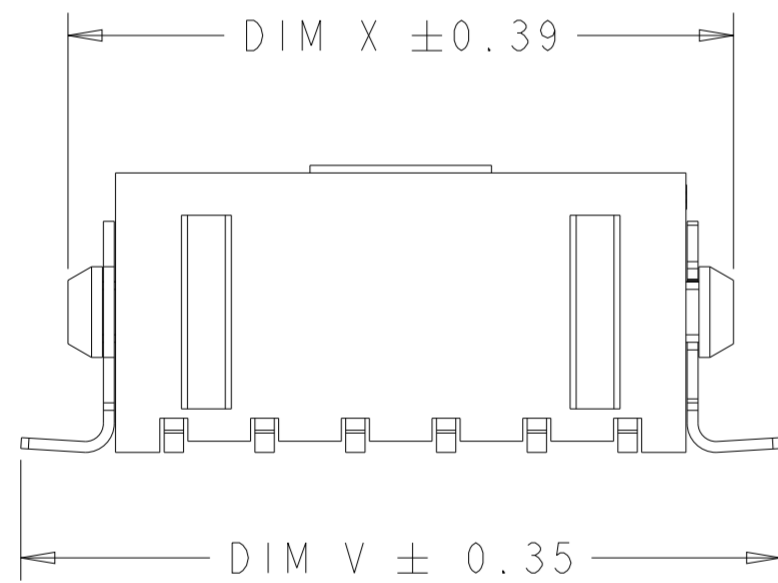
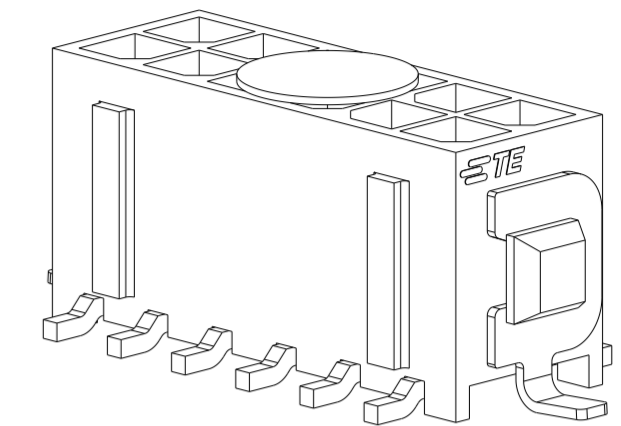
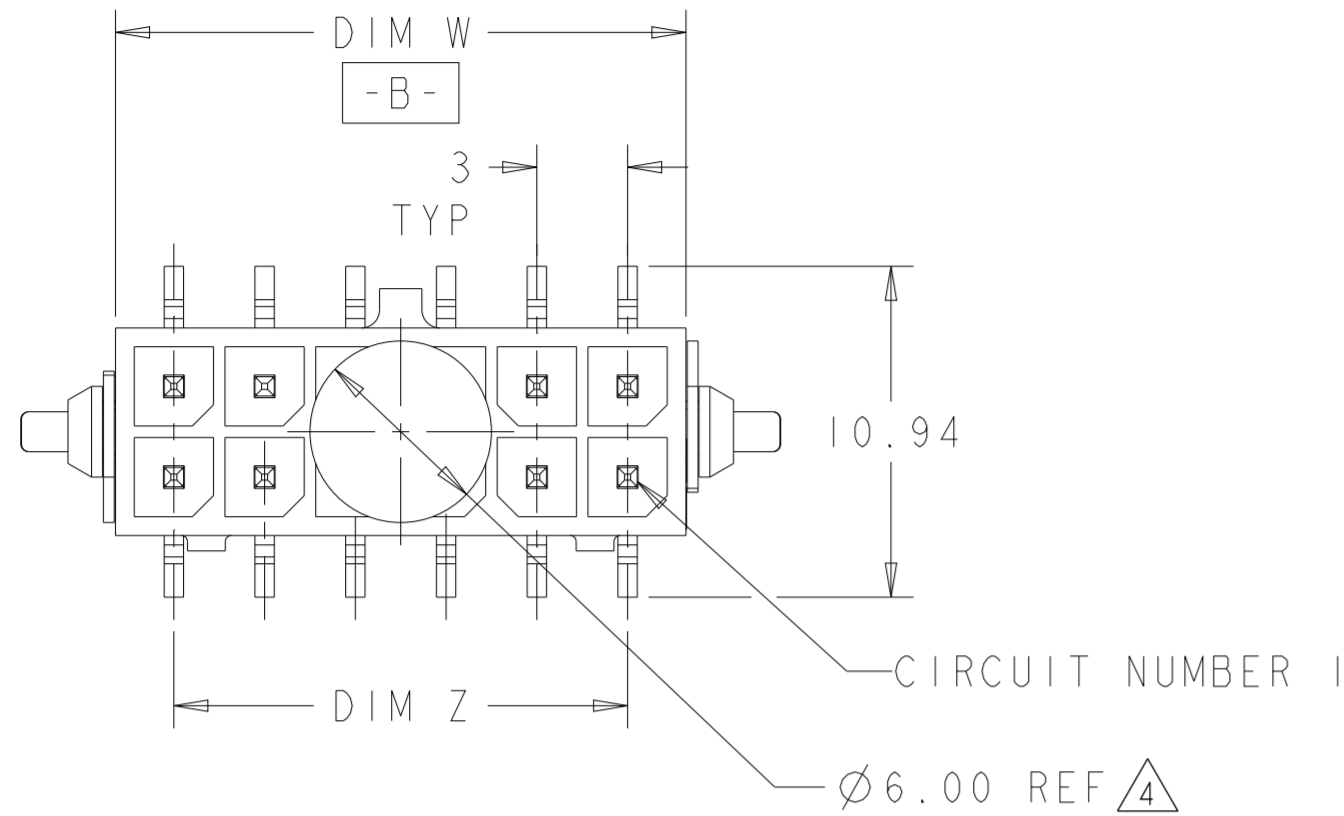

- 1 MATERIAL:
HOUSING - UL 94V-0 RATED HIGH TEMP NYLON, COLOR BLACK.
CONTACTS - BRASS.
HOLDDOWNS - PHOSPHOR BRONZE.
- 2 PLATING:
CONTACTS - 0.76µm MINIMUM GOLD ON MATING AREA.
2.54µm MINIMUM MATTE TIN ON SOLDER TAILS.
ALL OVER 1.27µm MINIMUM NICKEL.
HOLDDOWNS - 2.54µm MINIMUM MATTE TIN OVER 1.27µm MINIMUM NICKEL.
- 3 RECOMMENDED PC BOARD THICKNESS OF 1.57.
- 4 KAPTON VACUUM PICK UP BUTTON.
- 5 DIMENSION APPLIES TO SOLDER TAIL SURFACES AND STANDOFF SURFACES.
- 6 ALL SOLDER TAILS AND HOLDDOWNS.
- 7 SPECIAL PACKAGING FOR IEC 286-3 REQUIREMENT. PARTS ORIENTED 180° DIFFERENT IN TAPE THAN STANDARD PART NUMBER 794638.
- 8 COUNTERPART RECOMMENDED IS PN 794617 (DASH ACC. TO NUMBER OF POSITION).
- 9 FOR REELING DIRECTION AND PACKAGING TYPE, SEE SPECIFICATION 114-13000.

18.86	22.27	15.00	22.00	12	4-1586835-2
DIM W	DIM Y	DIM Z	DIM X	NO. OF POSN.	PART NUMBER

THIS DRAWING IS A CONTROLLED DOCUMENT.		DWN K. WHITAKER 12MAR2007	TE Connectivity		
DIMENSIONS: mm		CHK C. JONES 12MAR2007			
TOLERANCES UNLESS OTHERWISE SPECIFIED:		APVD C. JONES 12MAR2007	NAME HEADER ASSY, VERTICAL SURFACE MOUNT, SURF MNT HOLDDOWN, 30 GOLD, DUAL ROW, SPCL PKGING, MICRO MATE-N-LOK(TM)		
0 PLC ± 1 PLC ± 2 PLC ±0.13 3 PLC ± 4 PLC ± ANGLES ±1° FINISH		PRODUCT SPEC 108-1836	SIZE 114-13000	CAGE CODE A200779	DRAWING NO C-1586835
MATERIAL 1	2	APPLICATION SPEC 114-13000	WEIGHT -	RESTRICTED TO -	
CUSTOMER DRAWING			SCALE 4:1	SHEET 1 OF 2	REV C3

REVISIONS					
P	LTR	DESCRIPTION	DATE	DWN	APVD
-	-	SEE SHEET 1	-	-	-

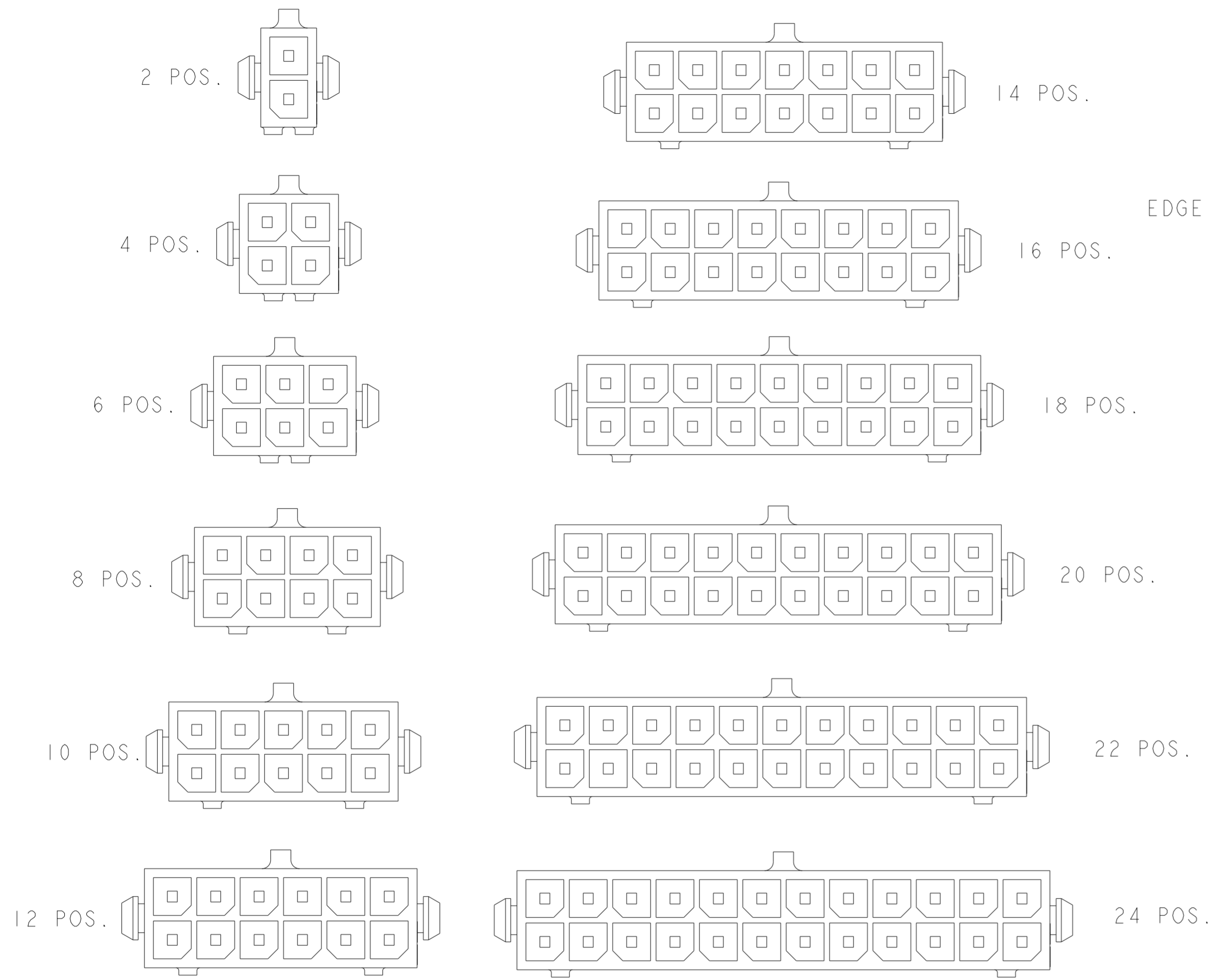

KEYING BY POSITION SIZE

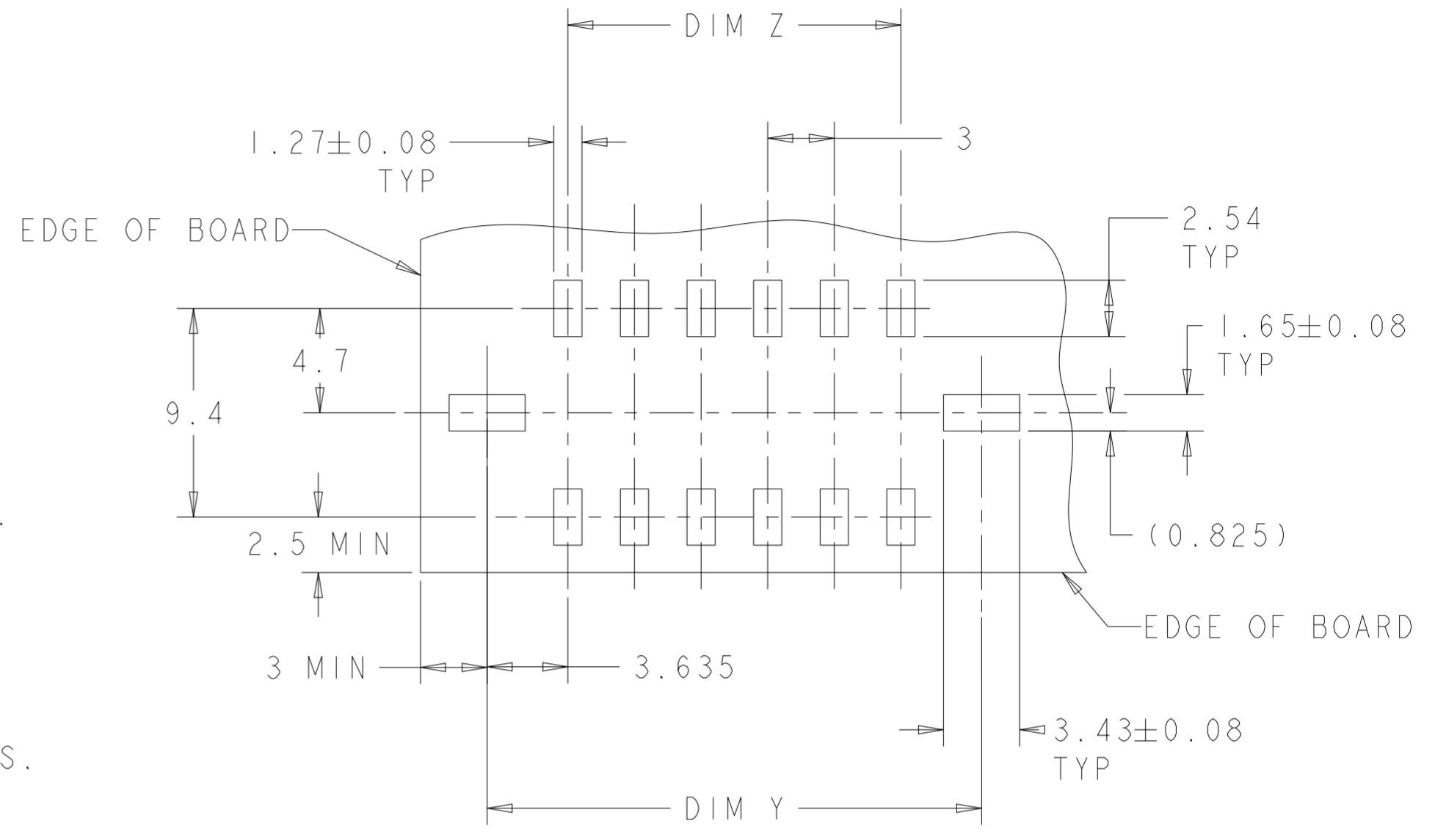

RECOMMENDED PCB LAYOUT (COMPONENT SIDE) $\triangle 3$

THIS DRAWING IS A CONTROLLED DOCUMENT.		DWN K. WHITAKER 12MAR2007	TE Connectivity	
DIMENSIONS: mm		CHK C. JONES 12MAR2007		
TOLERANCES UNLESS OTHERWISE SPECIFIED:		APVD C. JONES 12MAR2007	NAME HEADER ASSY, VERTICAL SURFACE MOUNT, SURF MNT HOLDDOWN, 30 GOLD, DUAL ROW, SPCL PKGING, MICRO MATE-N-LOK(TM)	
0 PLC ±		PRODUCT SPEC 108-1836	SIZE A200779	
1 PLC ±		APPLICATION SPEC 114-13000	CAGE CODE C-1586835	
2 PLC ±0.13		WEIGHT -	DRAWING NO -	
3 PLC ±		CUSTOMER DRAWING	RESTRICTED TO -	
4 PLC ±		SCALE 4:1	SHEET 2 OF 2	
ANGLES ±°			REV C3	
FINISH				