

REVISIONS					
REV	ECO	DESCRIPTION	DATE	BY	APPR
A3	-	RELEASE NEW DWG FORMAT	21/OCT/13	DRP	-
A4	C0405S	UPDATE DRAWING	21/JUL/15	JARRY	TOMMY
A5	C1070S	UPDATE DRAWING	28/JUN/19	JOE	TOMMY
B1	C1298S	UPDATE PLATING	14/SEP/20	SULLEN	TOMMY

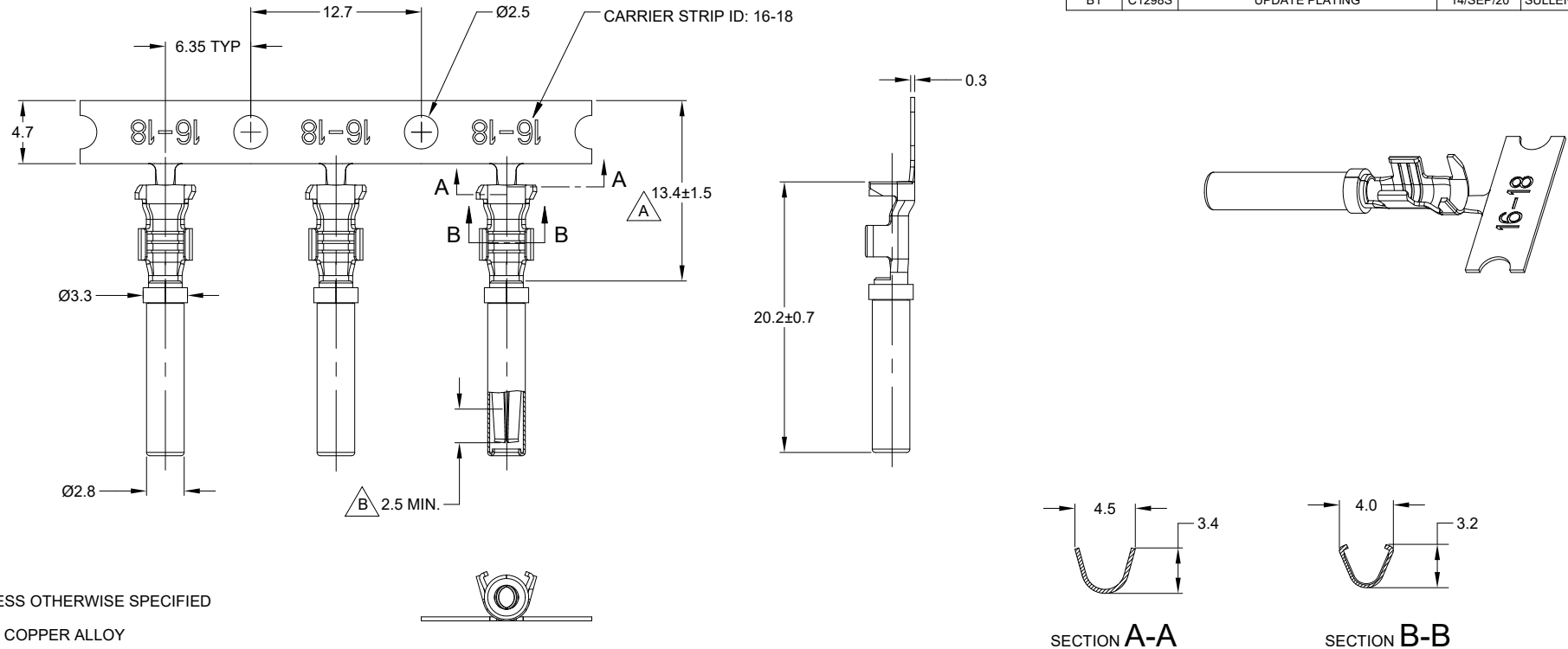

NOTES: UNLESS OTHERWISE SPECIFIED

- MATERIAL: COPPER ALLOY
- PLATING: SEE PART NUMBER CHART
- CONTACT SIZE: 16
- SPECIFICATIONS:
  - CURRENT RATING: 13 AMPS
  - CONTACT MILLIVOLT DROP: 100 MILLIVOLT DROP @ 13 AMP TEST CURRENT.
  - RoHS COMPLIANT
- RECOMMENDED WIRE RANGE: 16 - 18 AWG (1.5 - 0.75mm<sup>2</sup>)  
CUSTOMER OPTIONAL WIRE RANGE: 14 AWG (2.0mm<sup>2</sup>)  
RECOMMENDED INSUL O.D.: 1.91 - 3.55MM (0.075 - 0.140INCH)
- PACKAGE: 4000 PCS/REEL
- AVAILABLE APPLICATORS: MFX-3953-K OR MFX-3953-G
- ALL DIMENSIONS ARE FOR REFERENCE USE ONLY

PART NUMBER CHART		
PLATING	PART NUMBER	PLATING DESCRIPTION
NICKEL	AT62-16-0122	SELECTIVE TIN OVER NICKEL OVERALL IN $\Delta$ ZONE
GOLD	AT62-16-0144	SELECTIVE GOLD FLASH OVER NICKEL OVERALL IN $\Delta$ ZONE OR ENTIRE CONTACT
TIN	AT62-16-0177	TIN OVER NICKEL OVERALL

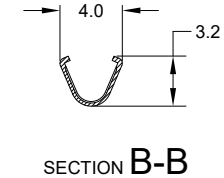
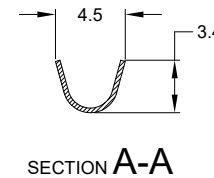

SEE PART NUMBER CHART		REF: 1062-16-0122, 1062-16-0144, 1062-16-0177	
PART NUMBER		DESCRIPTION	
QUANTITY	PART NUMBER	MATERIALS LIST	
		<p><b>Amphenol</b></p> <p>Sine Systems - www.amphenol-sine.com 44724 Morley Drive Clinton Township, MI 48036</p> <p>CONTACT, SOCKET, STAMPED, SIZE 16, 16-18 AWG, A SERIES</p>	
UNLESS OTHERWISE SPECIFIED		<p><b>SIGNATURES</b>      <b>DATE</b></p> <p>DRAWN: SULLENZHANG      14/SEP/20</p> <p>CHECKED: ORICLI      15/SEP/20</p> <p>ENGINEER:</p> <p>APPROVAL: TOMMY XIE      18/SEP/20</p> <p>CUSTOMER:</p>	
MATERIAL SPECIFICATIONS:		<p>THIS DRAWING IS SUPPLIED FOR INFORMATION ONLY. DESIGN FEATURES, SPECIFICATIONS AND PERFORMANCE DATA SHOWN HEREON ARE THE PROPERTY OF THE AMPHENOL CORPORATION. NO RIGHTS OF REPRODUCTION ARE IMPLIED. ALL DIMENSIONS ARE SUBJECT TO NORMAL MANUFACTURING VARIATIONS.</p>	
PROCESS SPECIFICATIONS:		<p>SCALE: NONE</p>	
NEXT ASSY:		<p>SIZE: B C-      TYPE:      DWG NO: AT62-16-01XX      REVISION: B1</p>	

TITLE: CONTACT, STAMPED, SIZE 16, 16-18 AWG, A SERIES  
DWG NO: AT62-16-01XX  
REV: B1  
SH: 1  
OF: 1