

THIS DRAWING IS UNPUBLISHED. RELEASED FOR PUBLICATION
 © COPYRIGHT - By - ALL RIGHTS RESERVED.

LOC	DIST	REVISIONS					
FT	0	P	LTR	DESCRIPTION	DATE	DWN	APVD
		K1		REVISED PER ECO-14-001124	24JAN2014	NK	MZ

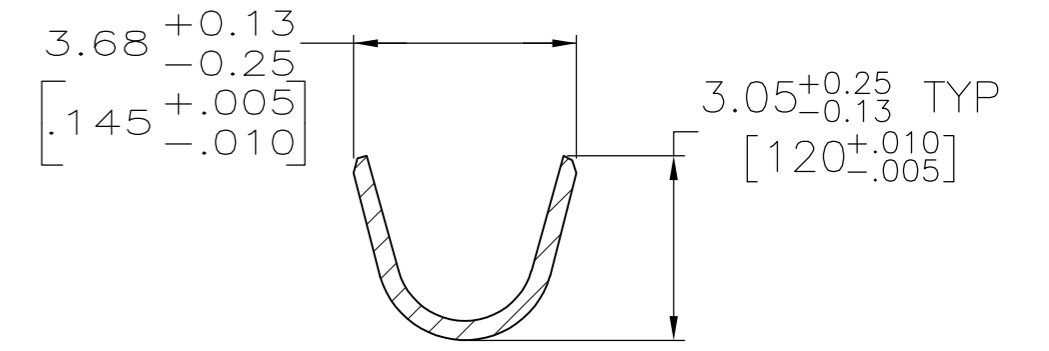

SECTION A-A

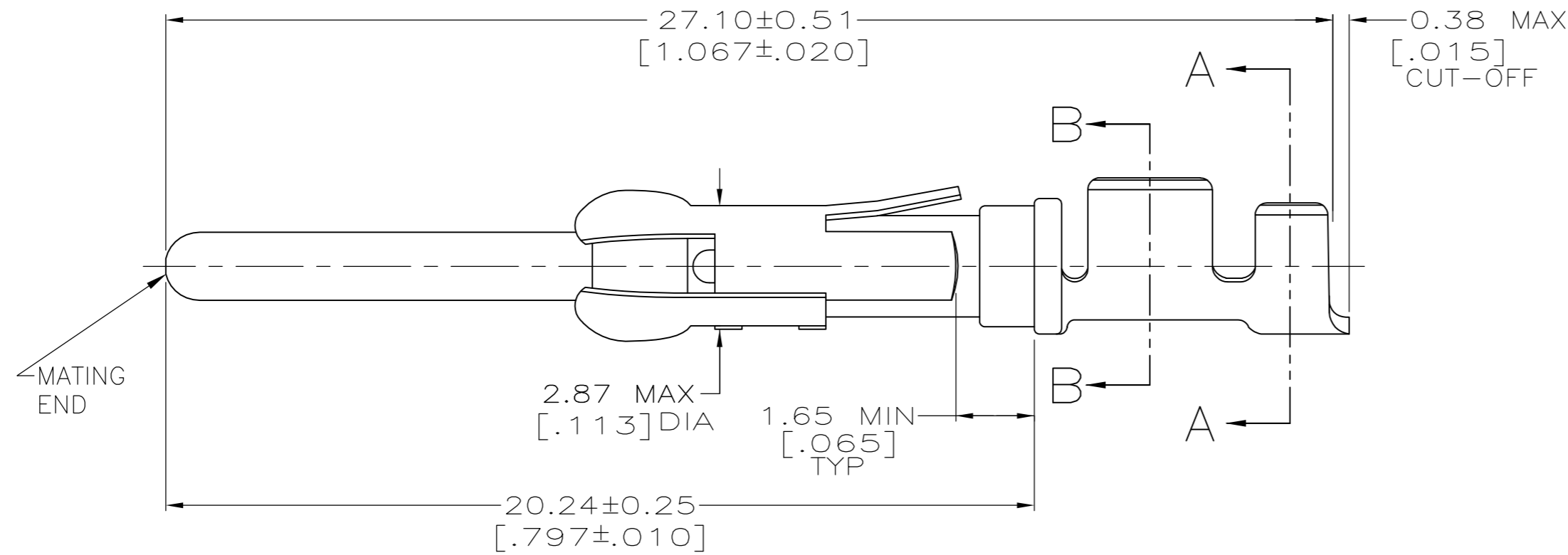
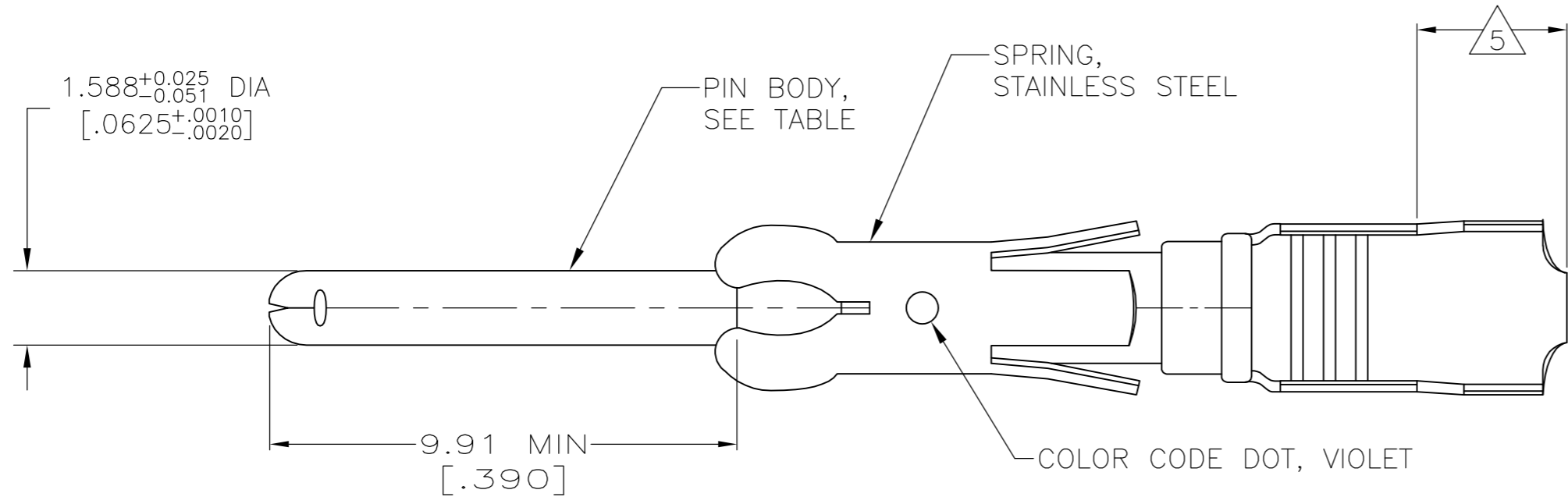
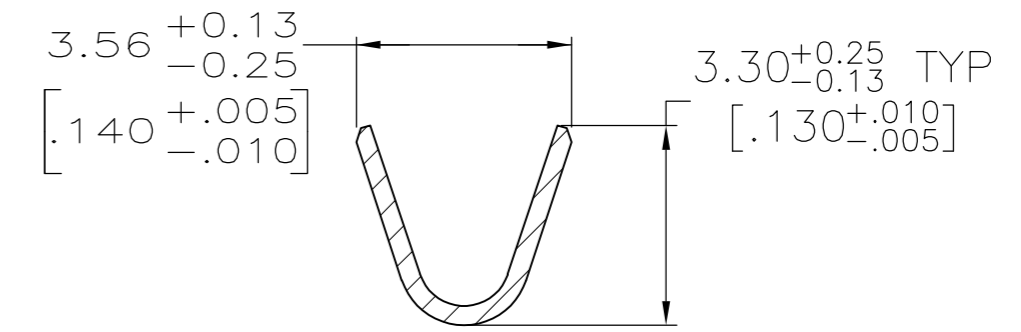

SECTION B-B

- 1 0.76µm [.000030] MIN PRECIOUS METAL PLATE ON MATING END FOR A LENGTH OF 5.08 [.200] MIN WITH 1.27µm [.000050] MIN NICKEL PLATE. GOLD FLASH ALL OVER. CONFORMS TO THE REQUIREMENTS OF TE CONNECTIVITY PRODUCT SPEC 108-10042, BASED ON EIA/ECA-364-1000.01A (CONTROLLED ENVIRONMENT APPLICATIONS).
- 2 0.76µm [.000030] MIN PRECIOUS METAL PLATE ON MATING END FOR A LENGTH OF 5.08 [.200] MIN WITH A UNIFORM GRADIENT TO 0.25µm [.000010] ON REMAINDER, OVER 1.27µm [.000050] MIN NICKEL PLATE. GOLD FLASH ALL OVER. CONFORMS TO THE REQUIREMENTS OF TE CONNECTIVITY PRODUCT SPEC 108-10042, BASED ON EIA/ECA-364-1000.01A (CONTROLLED ENVIRONMENT APPLICATIONS).
- 3 0.38µm [.000015] MIN GOLD PER MIL-G-45204 ON MATING END FOR A LENGTH OF 5.08 [.200] MIN WITH 1.27µm [.000050] MIN MATTE TIN PLATE IN WIRE CRIMP AREA, BOTH OVER 1.27µm [.000050] MIN NICKEL PER QQ-N-290.
- 4 1.27µm [.000050] MIN TIN-LEAD PER MIL-T-10727 OVER 1.27µm [.000050] MIN NICKEL PER QQ-N-290.
- 5 GOLD PLATING NOT REQUIRED IN THIS AREA.
- 6 WIRE RANGE 18-14 AWG.
- 7 INSULATION RANGE 2.03[.080]-2.54[.100] DIA.
- 8 0.38µm [.000015] MIN GOLD PER MIL-G-45204 ON MATING END FOR A LENGTH OF 5.08 [.200] MIN, 1.27µm [.000050] MIN TIN-LEAD PER MIL-T-10727 FOR A LENGTH OF 5.69 [.224] MIN ON OPPOSITE END, BOTH OVER 1.27µm [.000050] MIN NICKEL PER QQ-N-290 ON ENTIRE CONTACT.
- 9 1.27µm [.000050] MIN TIN PER MIL-T-10727 OVER 1.27µm [.000050] MIN NICKEL PER QQ-N-290.
- 10 0.76µm [.000030] MIN PRECIOUS METAL PLATE ON MATING END FOR A LENGTH OF 5.08 [.200] MIN WITH 1.27µm [.000050] MIN MATTE TIN PLATE IN WIRE CRIMP AREA, BOTH OVER 1.27µm [.000050] NICKEL PLATE. CONFORMS TO THE REQUIREMENTS OF TE CONNECTIVITY PRODUCT SPEC 108-10042, BASED ON EIA/ECA-364-1000.01A (CONTROLLED ENVIRONMENT APPLICATIONS).

STANDARD	9	CU-NI ALLOY	1-66359-9	1-66361-6	
STANDARD	4	CU-NI ALLOY	1-66359-7	1-66361-5	
STANDARD	1	CU-NI ALLOY	1-66359-6	1-66361-4	
SMALL PACK	9	BRASS	1-66359-4 OR 1-66359-8	1-66361-3	
STANDARD	9	BRASS	1-66359-4 OR 1-66359-8	1-66361-2	
SMALL PACK	10	BRASS	66359-4	1-66361-1	
SMALL PACK	4	BRASS	66359-2	1-66361-0	
OBSOLETE	STANDARD	8	BRASS	1-66359-3	66361-9
OBSOLETE	STANDARD	1	PHOSPHOR BRONZE	1-66359-2	66361-8
OBSOLETE	STANDARD	4	PHOSPHOR BRONZE	1-66359-1	66361-7
STANDARD	10	BRASS	66359-4	66361-4	
STANDARD	3	BRASS	66359-3	66361-3	
STANDARD	4	BRASS	66359-2	66361-2	
STANDARD	2	BRASS	66359-1	66361-1	
PACKAGING	BODY FINISH	BODY MATERIAL	STRIP P/N REF	PART NUMBER	

OBSOLETE
 OBSOLETE
 OBSOLETE

THIS DRAWING IS A CONTROLLED DOCUMENT.

DIMENSIONS: mm [INCHES]	TOLERANCES UNLESS OTHERWISE SPECIFIED: 0 PLC ± - 1 PLC ± - 2 PLC ± ± 0.13 [.005] 3 PLC ± - 4 PLC ± - ANGLES ± -	DWN L.SIPE 06/03/92 CHK W.LENKER 6-11-92 APVD G.STEINHAUER 7-8-92 PRODUCT SPEC - APPLICATION SPEC - WEIGHT -	NAME G. STEINHAUER SIZE A2 CAGE CODE 00779 DRAWING NO C=66361 SCALE 8:1 SHEET 1 OF 1 REV K1	TE Connectivity PIN ASSEMBLY, LOOSE PIECE, TYPE III+	RESTRICTED TO -
MATERIAL SEE CALLOUTS	FINISH SEE TABLE	CUSTOMER DRAWING			