

REF. SD-75586-001 FOR RECEPTACLE AND PCB LAYOUT INFORMATION

REF. SHEET 3 FOR GROUND PAD ALLEY LAYOUT INFORMATION

81.25 (MIN CENTER TO CENTER RAIL SPACING USING M2X0.4 FLAT HEAD OR BUTTON HEAD SCREWS)

CONDUCTIVE ZONE, GUIDE RAIL SIDE

POSITION LOWER EDGE OF OPENING FLUSH TO 0.10MM BELOW PCB SURFACE, TYP.

NOTES:

1. PCB AND BRACKET SHOWN FOR REFERENCE ONLY.
2. REF. SD-74547-100 FOR KEY POSITIONS
3. GUIDE HOUSING MOUNTING THREAD= M2 X 0.40. SEE SHEET 3 FOR SCREW LENGTH + TORQUE SPEC.
4. PLATE GROUND PAD WITH EMERSION SILVER OR GOLD.
5. MATERIAL:
GUIDE HOUSING - ZINC DIECAST, NICKEL PLATED
COVER - STAINLESS STEEL
6. NO RoHS EXEMPTIONS.
7. GUIDE HOUSING PEGS FOR ALIGNMENT ONLY, DO NOT SOLDER.

PART NUMBER	PORT SIZE	SW	OAW	KEY(S) PORT1	KEY(S) PORT2	KEY(S) PORT3	KEY(S) PORT4	IDENTIFIERS
745480200	4	76.30	80.00	1	1	1	1	SATA - 'X' CABLES
745480203	4	76.30	80.00	2,4	2,4	2,4	2,4	SAS OUT PORT/END DEVICE
745480204	4	76.30	80.00	4,6	4,6	4,6	4,6	SAS IN PORT/END DEVICE
745480205	4	76.30	80.00	4	4	4	4	SAS UNIVERSAL PORT
745480212	4	76.30	80.00	7	7	7	7	SATA - 'M' CABLES
745480217	4	76.30	80.00	2	2	2	2	SAS - OUT PORT
745480220	4	76.30	80.00	6	6	6	6	SAS - IN PORT
745480304	4	76.30	80.00	2,7	2,7	2,7	2,7	CX4
745480401	4	76.29	79.99	2,6	4	4	4	CUSTOM

IPASS IS A TRADE MARK OF MOLEX.

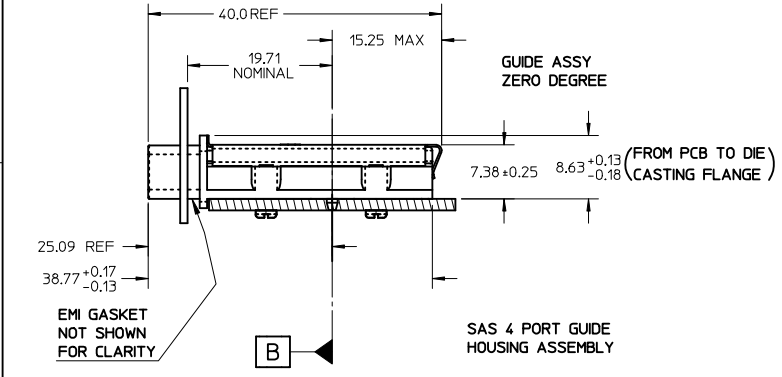

SAS 4 PORT GUIDE HOUSING ASSEMBLY

SEE REVISION TABLE

EC NO: CPG2015-0132	2013/09/27
DRWN:SYANG16	2013/09/27
CHKC:EWANG07	2014/08/15
APPR:RCHEN08	2014/08/15

REV	DESCRIPTION
F/0	QUALITY SYMBOLS
F/0	
F/0	

GENERAL TOLERANCES (UNLESS SPECIFIED)	
	mm INCH
4 PLACES	± --- ± ---
3 PLACES	± --- ± ---
2 PLACES	± 0.13 ± ---
1 PLACE	± 0.25 ± ---
0 PLACE	± ±
ANGULAR ±1/2°	
DRAFT WHERE APPLICABLE MUST REMAIN WITHIN DIMENSIONS	

DIMENSION STYLE	
MM ONLY	
DRAWN BY	DATE
SNABARRO	2006/05/26
CHECKED BY	DATE
BREED	2006/05/26
APPROVED BY	DATE
DDOYE	2006/05/26
MATERIAL NO.	DOCUMENT NO.
SEE TABLE	SD-74548-200

SCALE	DESIGN UNITS	THIRD ANGLE PROJECTION
1:1	METRIC	
TITLE		
I-PASS 26 CKT ZERO DEG. EMI GUIDE RAIL HOUSING ASSEMBLY, MULTI PORT		
molex		
DOCUMENT NO.		SHEET NO.
SD-74548-200		1 OF 4
THIS DRAWING CONTAINS INFORMATION THAT IS PROPRIETARY TO MOLEX INCORPORATED AND SHOULD NOT BE USED WITHOUT WRITTEN PERMISSION		

10 9 8 7 6 5 4 3 2 1

F

E

D

C

B

A

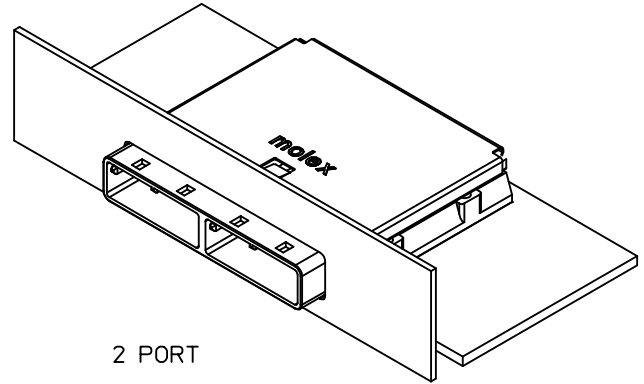
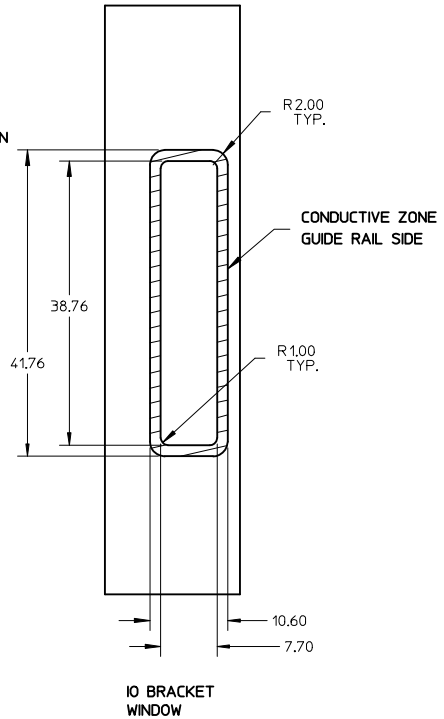
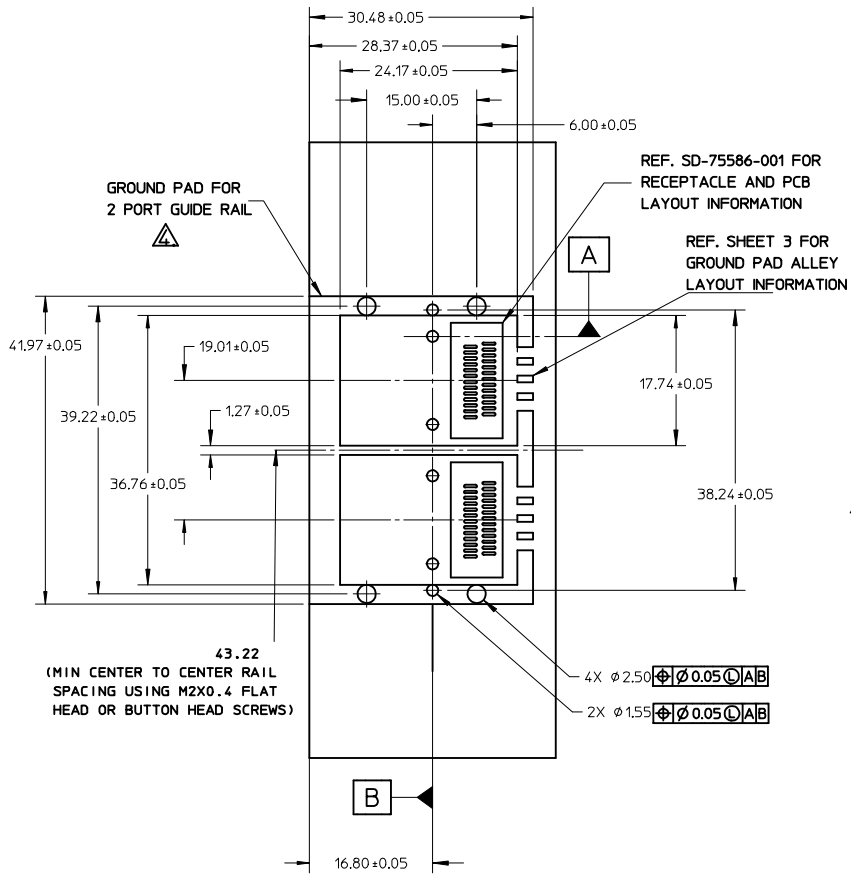

PART NUMBER	PORT SIZE	SW	OAW	KEY(S) PORT1	KEY(S) PORT2	IDENTIFIERS
745480202	2	38.26	41.96	1	1	SATA - 'X' CABLES
745480206	2	38.26	41.96	2,4	2,4	SAS OUT PORT/END DEVICE
745480207	2	38.26	41.96	4,6	4,6	SAS IN PORT/END DEVICE
745480208	2	38.26	41.96	4	4	SAS UNIVERSAL PORT
745480213	2	38.26	41.96	7	7	SATA - 'M' CABLES
745480215	2	38.26	41.96	4,6	2,4	SAS IN PORT - SAS OUT PORT
745480216	2	38.26	41.96	2,4	4,6	SAS OUT PORT - SAS IN PORT
745480218	2	38.26	41.96	2	2	SAS - IN PORT
745480221	2	38.26	41.96	6	6	SAS - OUT PORT
745480224	2	38.26	41.96	3	3	SRIO

I-PASS IS A TRADE MARK OF MOLEX.

SEE REVISION TABLE EC NO: CPG2015-0132 DRWN: SYANG16 2013/09/27 CHKD: WANG07 2014/08/15 APPR: RCHEN08 2014/08/19	QUALITY SYMBOLS	GENERAL TOLERANCES (UNLESS SPECIFIED)	DIMENSION STYLE	SCALE	DESIGN UNITS	THIRD ANGLE PROJECTION	
	$\nabla = 0$ $\nabla = 0$ $\nabla = 0$	mm INCH 4 PLACES ± --- ± --- 3 PLACES ± --- ± --- 2 PLACES ± 0.13 ± --- 1 PLACE ± 0.25 ± --- 0 PLACE ± ±	MM ONLY	1:1	METRIC	DRAWN BY DATE SNAVARRO 2006/05/26 CHECKED BY DATE BREED 2006/05/26 APPROVED BY DATE DDOYE 2006/05/26	TITLE
		ANGULAR ±1/2°				I-PASS 26 CKT ZERO DEG. EMI GUIDE RAIL HOUSING ASSEMBLY, MULTI PORT	
		DRAFT WHERE APPLICABLE MUST REMAIN WITHIN DIMENSIONS				molex MATERIAL NO. SEE TABLE DOCUMENT NO. SD-74548-200 SHEET NO. 2 OF 4	
						THIS DRAWING CONTAINS INFORMATION THAT IS PROPRIETARY TO MOLEX INCORPORATED AND SHOULD NOT BE USED WITHOUT WRITTEN PERMISSION	

9 8 7 6 5 4 3 2 1

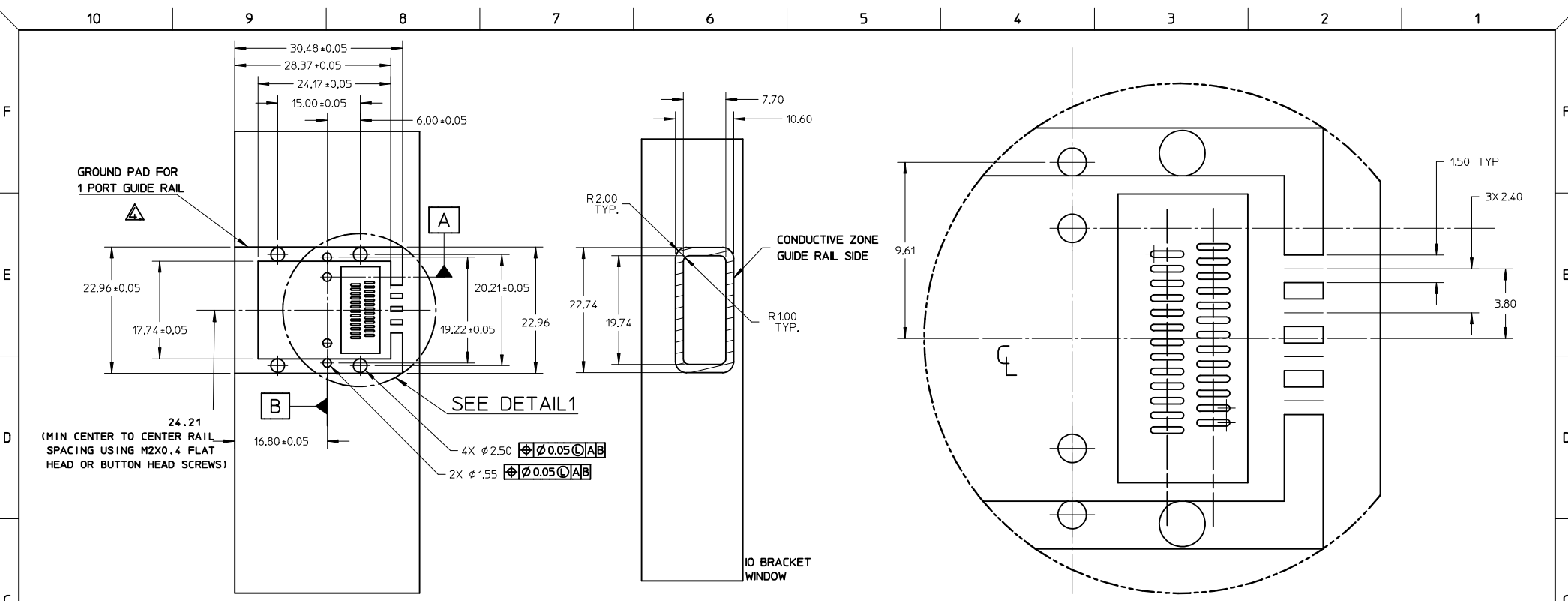

24.21
(MIN CENTER TO CENTER RAIL
SPACING USING M2X0.4 FLAT
HEAD OR BUTTON HEAD SCREWS)

SEE DETAIL 1

DETAIL 1
Scale 5:1

PART NUMBER	PORT SIZE	SW	OAW	KEY(S)	IDENTIFIERS
745480201	1	19.24	22.95	1	SATA - 'X' CABLES
745480209	1	19.24	22.95	2,4	SAS OUT PORT/END DEVICE
745480210	1	19.24	22.95	4,6	SAS IN PORT/END DEVICE
745480211	1	19.24	22.95	4	SAS UNIVERSAL PORT
745480214	1	19.24	22.95	7	SATA - 'M' CABLES
745480219	1	19.24	22.95	2	SAS OUT PORT
745480222	1	19.24	22.95	6	SAS IN PORT
745480225	1	19.24	22.95	3	SR10
745480229	1	19.24	22.95	2,7	CX4

PCB THICKNESS	SCREW LENGTH	TORQUE (IN LBS)
1.6 (.063')	5MM	2.3
2.38 (.093')	6MM	2.3
3.2 (.125')	6MM	2.3
X	+4MM MAX	2.3

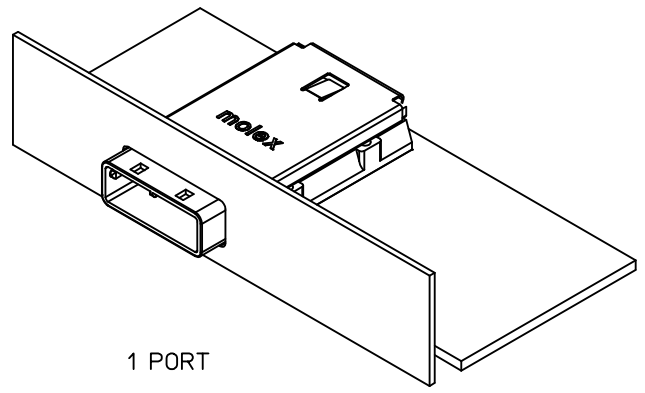

1 PORT

SEE REVISION TABLE
EC NO: CPG2015-0132
DRAWN: SYANG16 2013/09/27
CHKD: EWANG07 2014/08/15
APPR: RICHEN08 2014/08/19

QUALITY SYMBOLS	DESCRIPTION
$\nabla F=0$	
$\nabla E=0$	
$\nabla D=0$	

GENERAL TOLERANCES (UNLESS SPECIFIED)	DIMENSION STYLE
4 PLACES ± --- ± ---	MM ONLY
3 PLACES ± --- ± ---	
2 PLACES ± 0.13 ± ---	
1 PLACE ± 0.25 ± ---	
0 PLACE ± ±	
ANGULAR ± 1/2°	
DRAFT WHERE APPLICABLE MUST REMAIN WITHIN DIMENSIONS	

DRAWN BY	DATE
SNABARRO	2006/05/26
CHECKED BY	DATE
BREED	2006/05/26
APPROVED BY	DATE
DDOYE	2006/05/26
MATERIAL NO.	
SEE TABLE	

SCALE	DESIGN UNITS	THIRD ANGLE PROJECTION
1:1	METRIC	
TITLE I-PASS 26 CKT ZERO DEG. EMI GUIDE RAIL HOUSING ASSEMBLY, MULTI PORT		
molex		
DOCUMENT NO.	SD-74548-200	SHEET NO. 3 OF 4
THIS DRAWING CONTAINS INFORMATION THAT IS PROPRIETARY TO MOLEX INCORPORATED AND SHOULD NOT BE USED WITHOUT WRITTEN PERMISSION		

DATE	REV	DESCRIPTION
2014/08/14	U	1.CHANGED 40.0 TO 40.0 REF $\text{\textcircled{0}B9}$ [SHEET 1] 2.CHANGED DIM 25.09 TO 25.09 REF $\text{\textcircled{0}A10}$ BASED ON SFF-8088 [SHEET 1] 3.ADDED NOTE FOR DIM 8.63 +0.13/-0.18 $\text{\textcircled{0}A7}$ [SHEET 1] 4.ADDED DIM 15.25MAX $\text{\textcircled{0}B9}$ BASED ON SFF-8088 [SHEET 1] 5.ADDED REVISION HISTORY [SHEET 4]. 6.CHANGED ALL LOCATIONS OF DIMENSION MULTIPLIERS. (EX: "YY(3)" TO "3X YY")

SEE REVISION TABLE EC NO: CPG2015-0132 U DRWN:SYANG16 2013/09/27 CHKD:EWANG07 2014/08/15 APPR:RCHEN08 2014/08/19	QUALITY SYMBOLS	GENERAL TOLERANCES (UNLESS SPECIFIED)	DIMENSION STYLE	SCALE	DESIGN UNITS	THIRD ANGLE PROJECTION	
			MM ONLY	1:1	METRIC		
	$\nabla = 0$	4 PLACES	mm INCH	DRAWN BY DATE	TITLE I-PASS 26 CKT ZERO DEG. EMI GUIDE RAIL HOUSING ASSEMBLY, MULTI PORT		
	$\nabla = 0$	3 PLACES		SNAVARRO 2006/05/26			
	$\nabla = 0$	2 PLACES		CHECKED BY DATE	DOCUMENT NO. SD-74548-200 SHEET NO. 4 OF 4		
$\nabla = 0$	1 PLACE		BREED 2006/05/26				
	0 PLACE		APPROVED BY DATE	THIS DRAWING CONTAINS INFORMATION THAT IS PROPRIETARY TO MOLEX INCORPORATED AND SHOULD NOT BE USED WITHOUT WRITTEN PERMISSION			
			DDOYE 2006/05/26				

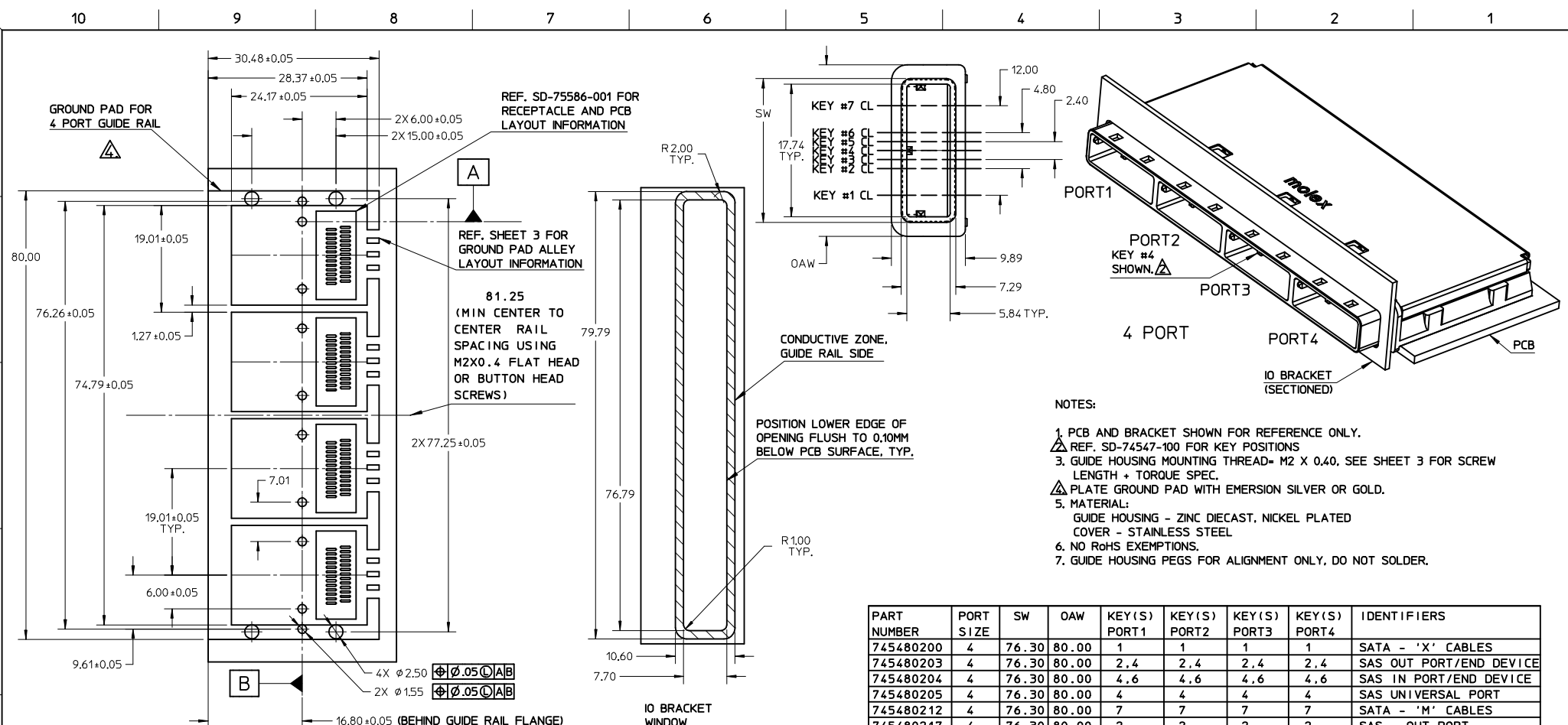

- NOTES:
1. PCB AND BRACKET SHOWN FOR REFERENCE ONLY.
 2. REF. SD-74547-100 FOR KEY POSITIONS
 3. GUIDE HOUSING MOUNTING THREAD= M2 X 0.40. SEE SHEET 3 FOR SCREW LENGTH + TORQUE SPEC.
 4. PLATE GROUND PAD WITH EMERSION SILVER OR GOLD.
 5. MATERIAL:
GUIDE HOUSING - ZINC DIECAST, NICKEL PLATED
COVER - STAINLESS STEEL
 6. NO RoHS EXEMPTIONS.
 7. GUIDE HOUSING PEGS FOR ALIGNMENT ONLY, DO NOT SOLDER.

PART NUMBER	PORT SIZE	SW	OAW	KEY(S) PORT1	KEY(S) PORT2	KEY(S) PORT3	KEY(S) PORT4	IDENTIFIERS
745480200	4	76.30	80.00	1	1	1	1	SATA - 'X' CABLES
745480203	4	76.30	80.00	2,4	2,4	2,4	2,4	SAS OUT PORT/END DEVICE
745480204	4	76.30	80.00	4,6	4,6	4,6	4,6	SAS IN PORT/END DEVICE
745480205	4	76.30	80.00	4	4	4	4	SAS UNIVERSAL PORT
745480212	4	76.30	80.00	7	7	7	7	SATA - 'M' CABLES
745480217	4	76.30	80.00	2	2	2	2	SAS - OUT PORT
745480220	4	76.30	80.00	6	6	6	6	SAS - IN PORT
745480304	4	76.30	80.00	2,7	2,7	2,7	2,7	CX4
745480401	4	76.29	79.99	2,6	4	4	4	CUSTOM

IPASS IS A TRADE MARK OF MOLEX.

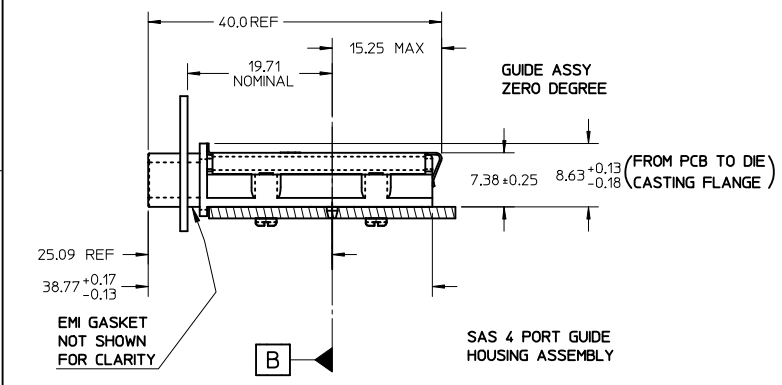

SEE REVISION TABLE EC NO: CPG2015-0132 DRWN:SYANG16 2013/09/27 CHK:EWANG07 2014/08/15 APPR:RCHEN08 2014/08/19	QUALITY SYMBOLS F=0 F=0 F=0	GENERAL TOLERANCES (UNLESS SPECIFIED) mm INCH 4 PLACES ± --- ± --- 3 PLACES ± --- ± --- 2 PLACES ± 0.13 ± --- 1 PLACE ± 0.25 ± --- 0 PLACE ± ±	DIMENSION STYLE MM ONLY DRAWN BY SNAVARRO DATE 2006/05/26 CHECKED BY BREED DATE 2006/05/26 APPROVED BY DDOYE DATE 2006/05/26	SCALE 1:1 DESIGN UNITS METRIC THIRD ANGLE PROJECTION	TITLE I-PASS 26 CKT ZERO DEG. EMI GUIDE RAIL HOUSING ASSEMBLY, MULTI PORT DOCUMENT NO. SD-74548-200 SHEET NO. 1 OF 4
	ANGULAR ±1/2° DRAFT WHERE APPLICABLE MUST REMAIN WITHIN DIMENSIONS	MATERIAL NO. SEE TABLE	THIS DRAWING CONTAINS INFORMATION THAT IS PROPRIETARY TO MOLEX INCORPORATED AND SHOULD NOT BE USED WITHOUT WRITTEN PERMISSION		
	SEE REVISION TABLE	MATERIAL NO. SEE TABLE	THIS DRAWING CONTAINS INFORMATION THAT IS PROPRIETARY TO MOLEX INCORPORATED AND SHOULD NOT BE USED WITHOUT WRITTEN PERMISSION		
	SEE REVISION TABLE	MATERIAL NO. SEE TABLE	THIS DRAWING CONTAINS INFORMATION THAT IS PROPRIETARY TO MOLEX INCORPORATED AND SHOULD NOT BE USED WITHOUT WRITTEN PERMISSION		

10 9 8 7 6 5 4 3 2 1

F

E

D

C

B

A

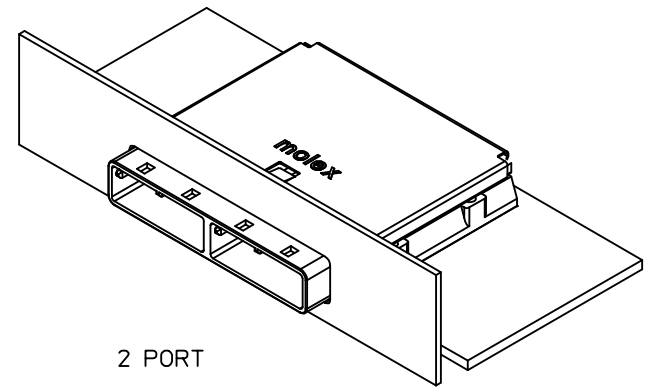
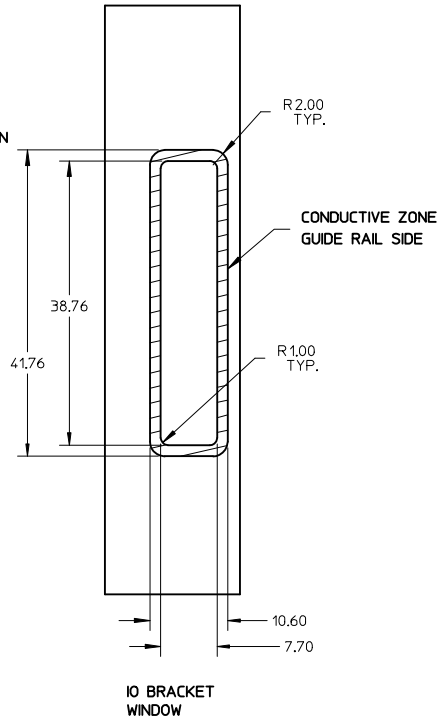
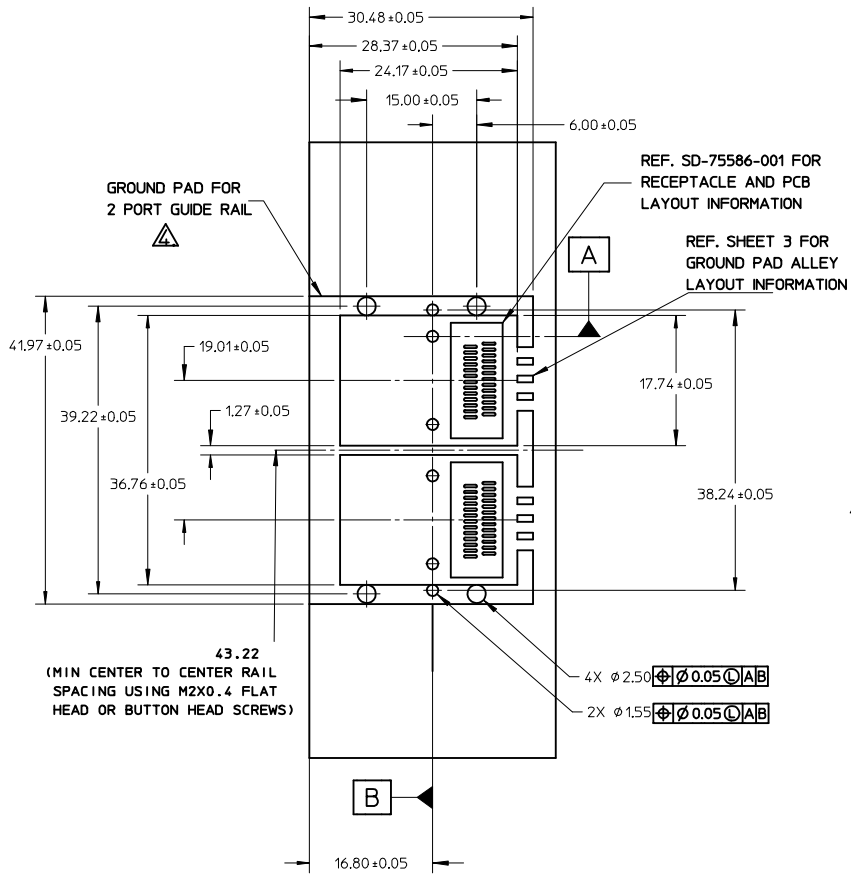

PART NUMBER	PORT SIZE	SW	OAW	KEY(S) PORT1	KEY(S) PORT2	IDENTIFIERS
745480202	2	38.26	41.96	1	1	SATA - 'X' CABLES
745480206	2	38.26	41.96	2,4	2,4	SAS OUT PORT/END DEVICE
745480207	2	38.26	41.96	4,6	4,6	SAS IN PORT/END DEVICE
745480208	2	38.26	41.96	4	4	SAS UNIVERSAL PORT
745480213	2	38.26	41.96	7	7	SATA - 'M' CABLES
745480215	2	38.26	41.96	4,6	2,4	SAS IN PORT - SAS OUT PORT
745480216	2	38.26	41.96	2,4	4,6	SAS OUT PORT - SAS IN PORT
745480218	2	38.26	41.96	2	2	SAS - IN PORT
745480221	2	38.26	41.96	6	6	SAS - OUT PORT
745480224	2	38.26	41.96	3	3	SRIO

I-PASS IS A TRADE MARK OF MOLEX.

SEE REVISION TABLE EC NO: CPG2015-0132 DRWN: SYANG16 2013/09/27 CHKD: WANG07 2014/08/15 APPR: RCHEN08 2014/08/19	QUALITY SYMBOLS	GENERAL TOLERANCES (UNLESS SPECIFIED)	DIMENSION STYLE	SCALE	DESIGN UNITS	THIRD ANGLE PROJECTION
	$\nabla = 0$ $\nabla = 0$ $\nabla = 0$	mm INCH 4 PLACES ± --- ± --- 3 PLACES ± --- ± --- 2 PLACES ± 0.13 ± --- 1 PLACE ± 0.25 ± --- 0 PLACE ± ±	MM ONLY	1:1	METRIC	DRAWN BY DATE SNAVARRO 2006/05/26 CHECKED BY DATE BREED 2006/05/26 APPROVED BY DATE DDOYE 2006/05/26
	ANGULAR ± 1/2° DRAFT WHERE APPLICABLE MUST REMAIN WITHIN DIMENSIONS	MATERIAL NO.	DOCUMENT NO.	TITLE I-PASS 26 CKT ZERO DEG. EMI GUIDE RAIL HOUSING ASSEMBLY, MULTI PORT		
	SEE TABLE SIZE B	SEE TABLE THIS DRAWING CONTAINS INFORMATION THAT IS PROPRIETARY TO MOLEX INCORPORATED AND SHOULD NOT BE USED WITHOUT WRITTEN PERMISSION	SD-74548-200	SHEET NO. 2 OF 4		

9 8 7 6 5 4 3 2 1

DATE	REV	DESCRIPTION
2014/08/14	U	1.CHANGED 40.0 TO 40.0 REF $\text{\textcircled{0}B9}$ [SHEET 1] 2.CHANGED DIM 25.09 TO 25.09 REF $\text{\textcircled{0}A10}$ BASED ON SFF-8088 [SHEET 1] 3.ADDED NOTE FOR DIM 8.63 +0.13/-0.18 $\text{\textcircled{0}A7}$ [SHEET 1] 4.ADDED DIM 15.25MAX $\text{\textcircled{0}B9}$ BASED ON SFF-8088 [SHEET 1] 5.ADDED REVISION HISTORY [SHEET 4]. 6.CHANGED ALL LOCATIONS OF DIMENSION MULTIPLIERS. (EX: "YY(3)" TO "3X YY")

SEE REVISION TABLE EC NO: CPG2015-0132 U DRWN:SYANG16 2013/09/27 CHKD:EWANG07 2014/08/15 APPR:RCHEN08 2014/08/19	QUALITY SYMBOLS	GENERAL TOLERANCES (UNLESS SPECIFIED)	DIMENSION STYLE	SCALE	DESIGN UNITS	THIRD ANGLE PROJECTION	
	$\nabla = 0$	mm INCH	MM ONLY	1:1	METRIC		
	$\nabla = 0$	4 PLACES ± --- ± ---	DRAWN BY DATE	TITLE I-PASS 26 CKT ZERO DEG. EMI GUIDE RAIL HOUSING ASSEMBLY, MULTI PORT			
	$\nabla = 0$	3 PLACES ± --- ± ---	SNAVARRO 2006/05/26				
	$\nabla = 0$	2 PLACES ± 0.13 ± ---	CHECKED BY DATE	DOCUMENT NO. SD-74548-200 SHEET NO. 4 OF 4			
	1 PLACE ± 0.25 ± ---	BREED 2006/05/26					
	0 PLACE ± ±	APPROVED BY DATE	THIS DRAWING CONTAINS INFORMATION THAT IS PROPRIETARY TO MOLEX INCORPORATED AND SHOULD NOT BE USED WITHOUT WRITTEN PERMISSION				
	ANGULAR ± 1/2°	DDOYE 2006/05/26					
	DRAFT WHERE APPLICABLE MUST REMAIN WITHIN DIMENSIONS	MATERIAL NO.	SEE TABLE				