



LV3313PM

Bi-CMOS LSI

Electronic Volume IC for Car Audio Systems

ON Semiconductor®

<http://onsemi.com>

Overview

The LV3313PM is an electronic volume IC that implements a rich set of audio control functions including input selection switching function, an input gain, volume, loudness, balance, fader, and bass/treble control.

Features

- Zero-cross switching circuits (Input gain control block and Volume control block) can switch signal detection location automatically.
- Zero-cross switching circuits (Input gain control block and Volume control block) and soft mute circuits used for low noise even when input signals are present.
- Low power consumption due to the use of BiMOS process.
- All functions are controlled using serial data (CCB).

Functions

- Input selector :
Four input signals can be selected (three single-ended inputs and one differential input).
- Input gain control :
The input signal can be amplified by 0dB to +18dB (1dB steps).
- Loudness control :
Taps are output starting at the -32dB position of the ladder resistor and a loudness function implemented with external capacitor and resistor components.
- Volume control : +10dB to -79dB/-∞ (1dB steps)
L/R independent control.
- Bass control : +12dB to -12dB in 2dB steps
- Treble control : +12dB to -12dB in 2dB steps
- Fader control :
The fader volume can be attenuations by one of 16 levels. Independent control each four channels. (A total of 16 settings with attenuations of 0dB to -2dB in 1dB steps, -2dB to -20dB in 2dB steps, and -30dB, -45dB, -60dB and -∞dB settings.)
- Mute

• CCB is ON Semiconductor®'s original format. All addresses are managed by ON Semiconductor® for this format.

- CCB is a registered trademark of Semiconductor Components Industries, LLC.

LV3313PM

Specifications

Absolute Maximum Ratings at $T_a = 25^\circ\text{C}$, $V_{SS} = 0\text{V}$

Parameter	Symbol	Conditions	Ratings	Unit
Maximum supply voltage	$V_{DD\text{ max}}$	V_{DD}	9.5	V
Maximum input voltage	$V_{IN\text{ max}}$	All input pins	$V_{SS}-0.3$ to V_{DD}	V
Allowable power dissipation	$P_d\text{ max}$	$T_a \leq 85^\circ\text{C}$, when mounted on a printed circuit board *	600	mW
Operating temperature	T_{opr}		-40 to +85	$^\circ\text{C}$
Storage temperature	T_{stg}		-50 to +125	$^\circ\text{C}$

* Specified circuit board : $114.3 \times 76.1 \times 1.6\text{mm}^3$: glass epoxy board

Stresses exceeding Maximum Ratings may damage the device. Maximum Ratings are stress ratings only. Functional operation above the Recommended Operating Conditions is not implied. Extended exposure to stresses above the Recommended Operating Conditions may affect device reliability.

Allowable Operating Ratings at $T_a = 25^\circ\text{C}$, $V_{SS} = 0\text{V}$

Parameter	Symbol	Conditions	Ratings			Unit
			min	typ	max	
Supply voltage	V_{DD}	V_{DD}	7.0	8.0	9.0	V
High-level input voltage	V_{IH}	CL, DI, CE	3.0		5.5	V
Low-level input voltage	V_{IL}	CL, DI, CE	V_{SS}		1.0	V
Input voltage amplitude	V_{IN}		V_{SS}		V_{DD}	Vp-p
Input pulse width	$T_{\phi W}$	CL	1			μs
Setup time	T_{setup}	CL, DI, CE	1			μs
Hold time	T_{hold}	CL, DI, CE	1			μs
Operating frequency	fopg	CL			500	kHz
Rising time	t_r	CL, DI, CE			0.1/fopg	s
Falling time	t_f					

Electrical Characteristics at $T_a = 25^\circ\text{C}$, $V_{DD} = 8\text{V}$, $V_{SS} = 0\text{V}$

Parameter	Symbol	Conditions	Ratings			Unit
			min	typ	max	
Input block						
Input resistance	R_{in}	L1-L3, R1-R3	35	50	65	$\text{k}\Omega$
Minimum input gain	$G_{in\text{ min}}$	L1-L3, R1-R3	-1.0	0	+1.0	dB
Maximum input gain	$G_{i\text{ max}}$		+17	+18	+19	dB
Inter-step setting error	A_{Terr}		-1.0		+1.0	dB
Left/Right balance	BAL		-0.5		+0.5	dB
Volume block						
Input resistance	R_{vr}	LVRIN, RVRIN	35	50	65	$\text{k}\Omega$
Inter-step setting error	A_{Terr}	+10dB to -40dB	-0.5		+0.5	dB
Left/Right balance	BAL		-0.5		+0.5	dB
Bass block						
Bass control range	$G_b\text{ max}$	max. boost/cut	± 10	± 12	± 14	dB
Inter-step setting error	A_{Terr}	-10dB to +10dB	-0.5		+0.5	dB
Left/Right balance	BAL		-0.5		+0.5	dB
Treble block						
Treble control range	$G_b\text{ max}$	max. boost/cut	± 10	± 12	± 14	dB
Inter-step setting error	A_{Terr}	-10dB to +10dB	-0.5		+0.5	dB
Left/Right balance	BAL		-0.5		+0.5	dB
Fader block						
Input resistance	R_{fed}		35	50	65	$\text{k}\Omega$
Inter-step setting error	A_{Terr}	0dB to -2dB	-0.5		+0.5	dB
		-4dB to -20dB	-1.0		+1.0	dB
		-30dB	-2.0		+2.0	dB
		-45dB	-3.0		+3.0	dB
Left/Right balance	BAL	0dB to -30dB	-0.5		+0.5	dB

LV3313PM

Overall Characteristics at $T_a = 25^\circ\text{C}$, $V_{DD} = 8\text{V}$, $V_{SS} = 0\text{V}$

Parameter	Symbol	Conditions	Ratings			Unit
			min	typ	max	
A loss of insertion	ATT		-1.0		+1.0	dB
Total harmonic distortion	THD	$V_{IN} = 1\text{Vrms}$, $f = 1\text{kHz}$		0.004	0.01	%
Inter-input crosstalk	CT	$V_{IN} = 1\text{Vrms}$, $f = 1\text{kHz}$	80	88		dB
Left/Right channel crosstalk	CT	$V_{IN} = 1\text{Vrms}$, $f = 1\text{kHz}$	80	88		dB
Maximum attenuation	V_O min	$V_{IN} = 1\text{Vrms}$, $f = 1\text{kHz}$	80	88		dB
Output noise voltage	VN			10	25	μV
Current drain	I_{DD}			16	23	mA
Input high-level current	I_{IH}	CL, DI, CE, $V_{IN} = 5.5\text{V}$			10	μA
Input low-level current	I_{IL}	CL, DI, CE, $V_{IN} = 0\text{V}$	-10			μA
Maximum input voltage	VCL	THD = 1% $R_L = 10\text{k}\Omega$ all controls flat, $f_{IN} = 1\text{kHz}$		2.2		Vrms
Common-mode rejection ratio	CMRR	$V_{IN} = 1\text{Vrms}$, $f = 1\text{kHz}$		50		dB

Package Dimensions

unit : mm (typ)

3148A

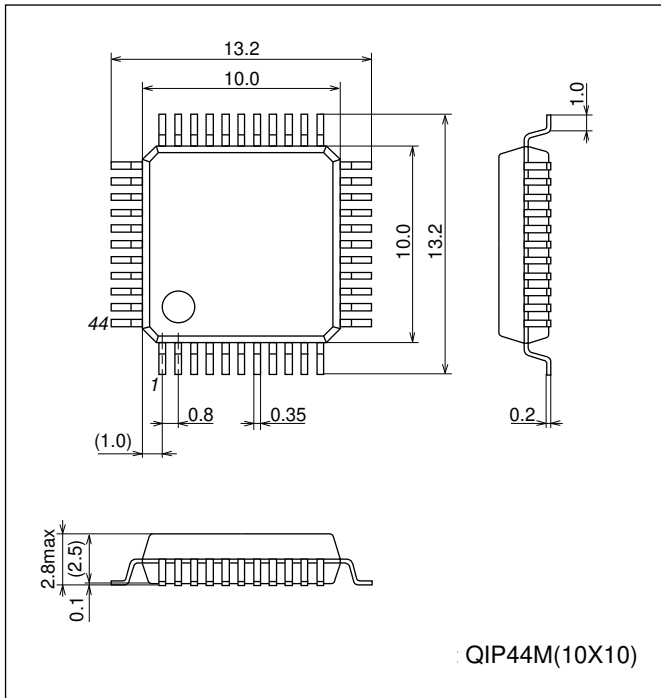

LV3313PM

Pin Assignment

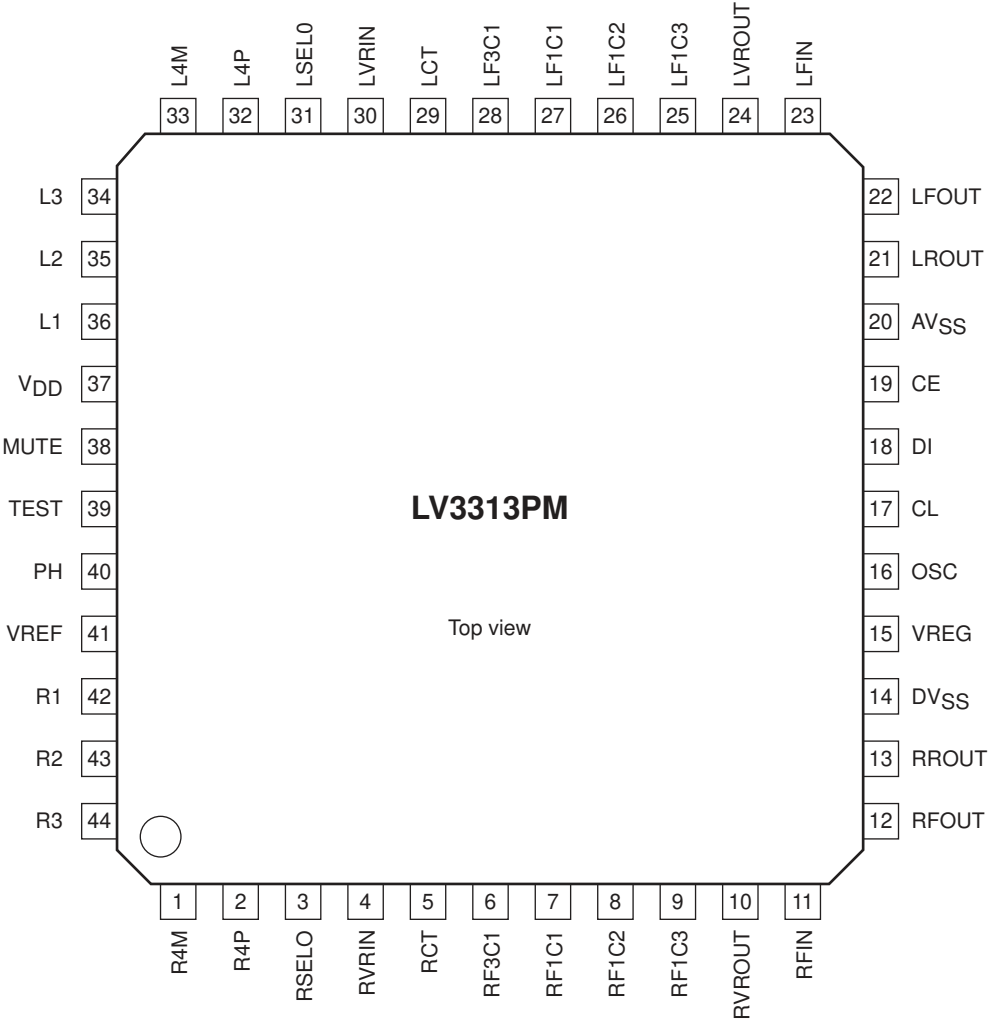

LV3313PM

Block Diagram

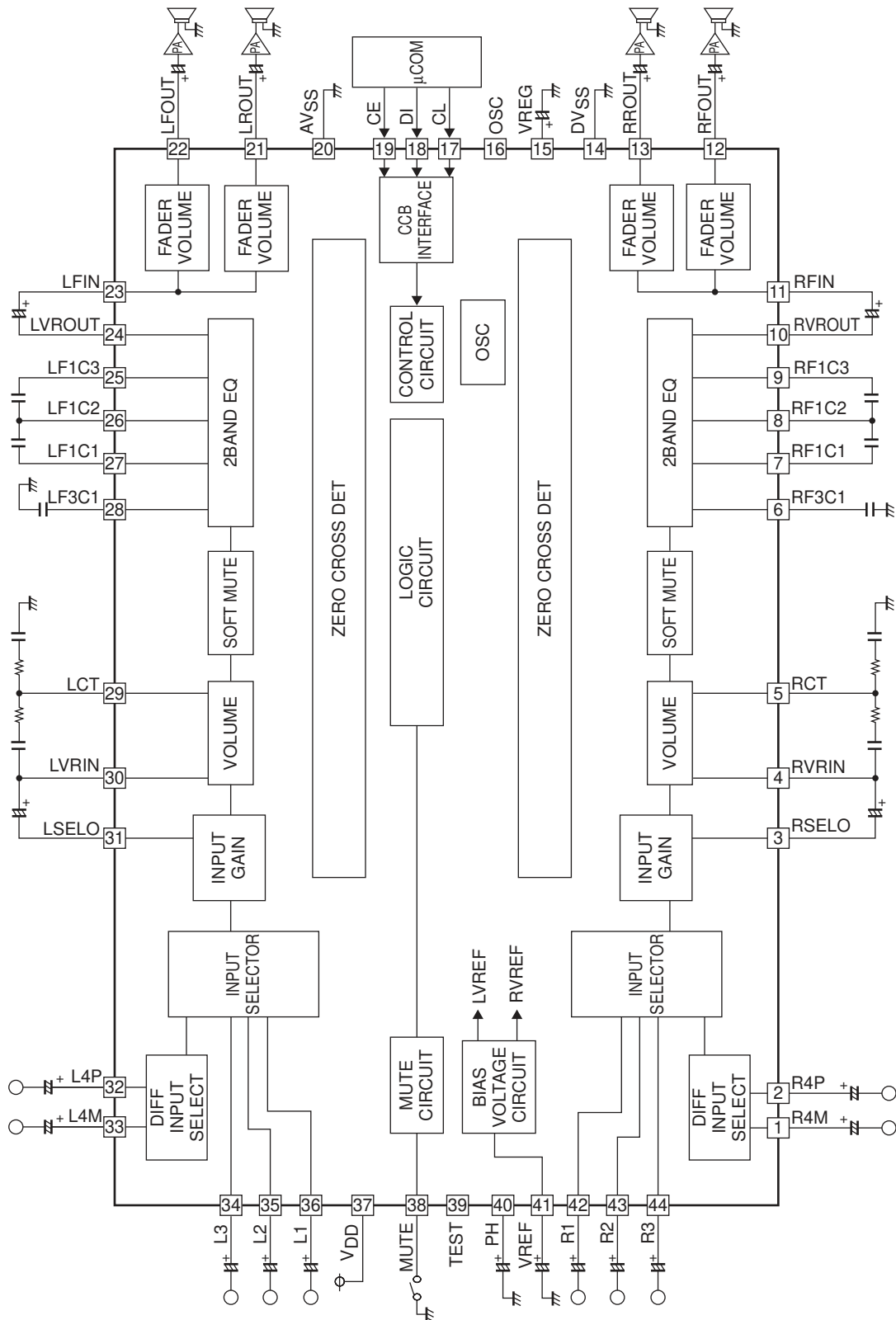

LV3313PM

Application Circuit

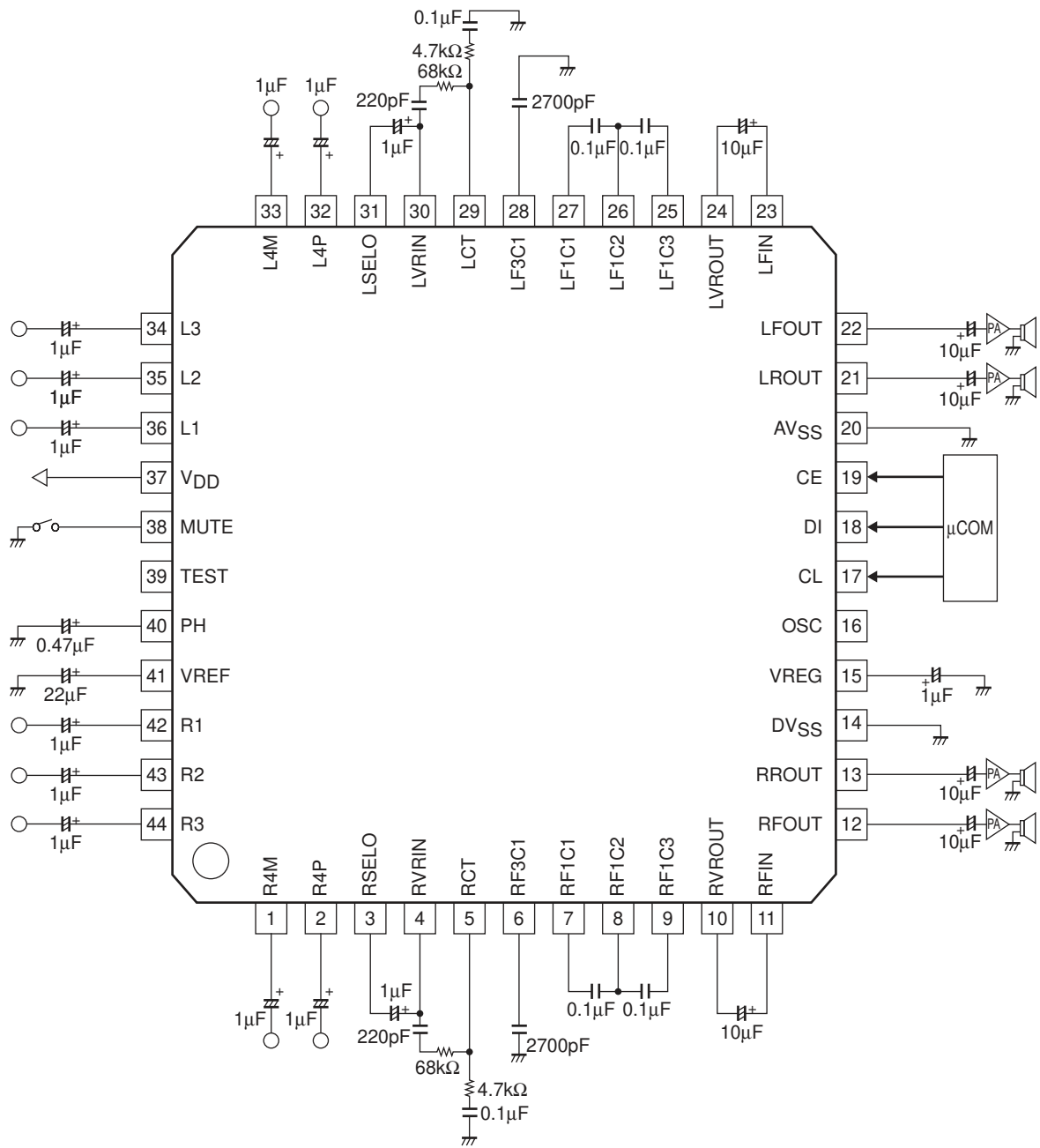

LV3313PM

Control System Timing and Data Format

The LV3313PM is controlled by applying the stipulated data to the CL, DI and CE pins. The data consists of a total of 104 bits, of which 8 bits are the device address, 96 bits are the control data.

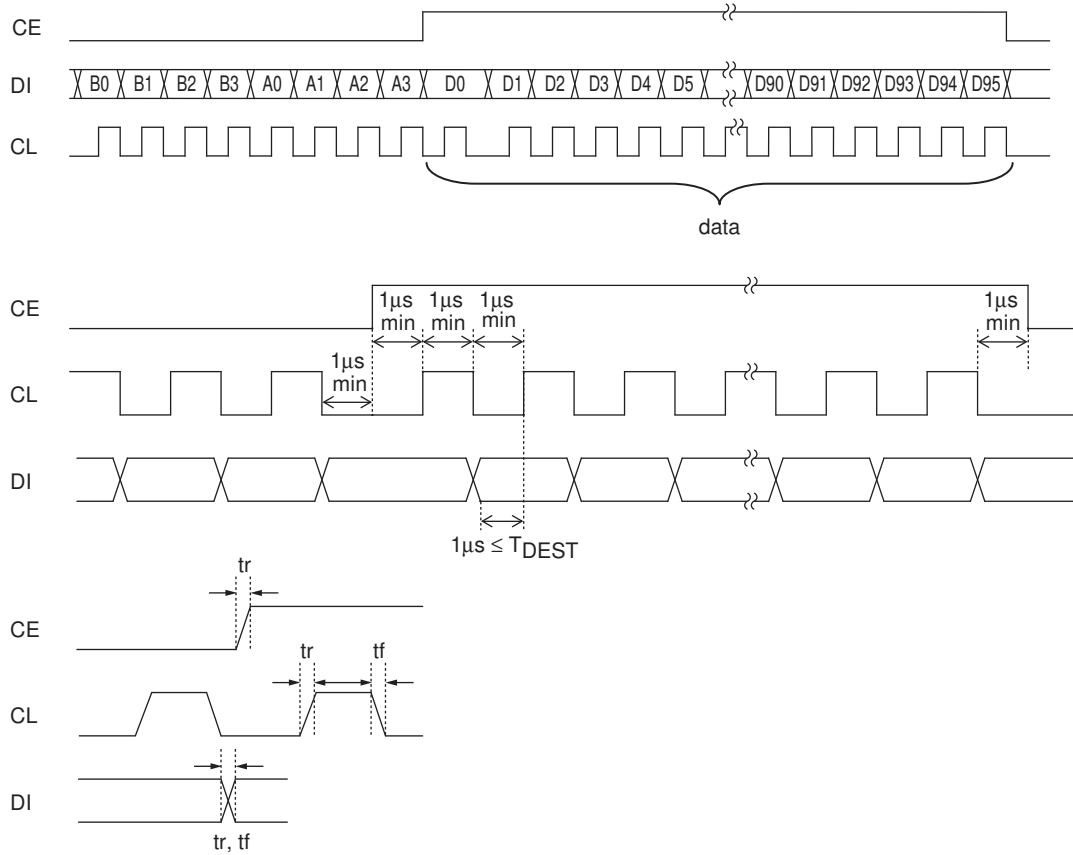

Send to data

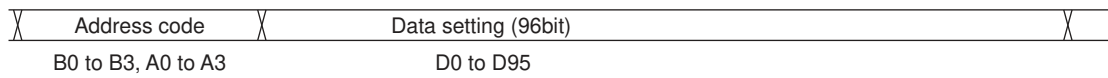

Address code

B0	B1	B2	B3	A0	A1	A2	A3
1	0	0	0	0	0	0	1

LV3313PM

Data setting

Input switching control

D0	D1	D2	Operation
0	0	0	INIT
1	0	0	L1 (R1)
0	1	0	L2 (R2)
1	1	0	L3 (R3)
0	0	1	L4 (R4)

Input gain control

D3	D4	D5	D6	D7	Lch
D8	D9	D10	D11	D12	Rch
0	0	0	0	0	0dB
1	0	0	0	0	+1dB
0	1	0	0	0	+2dB
1	1	0	0	0	+3dB
0	0	1	0	0	+4dB
1	0	1	0	0	+5dB
0	1	1	0	0	+6dB
1	1	1	0	0	+7dB
0	0	0	1	0	+8dB
1	0	0	1	0	+9dB
0	1	0	1	0	+10dB
1	1	0	1	0	+11dB
0	0	1	1	0	+12dB
1	0	1	1	0	+13dB
0	1	1	1	0	+14dB
1	1	1	1	0	+15dB
0	0	0	0	1	+16dB
1	0	0	0	1	+17dB
0	1	0	0	1	+18dB

LV3313PM

Volume control (10dB to -43dB)

D13	D14	D15	D16	D17	D18	D19	D20	Lch
D21	D22	D23	D24	D25	D26	D27	D28	Rch
0	1	1	0	1	1	1	0	10dB
1	1	1	0	1	1	1	0	9dB
0	0	0	1	1	1	1	0	8dB
1	0	0	1	1	1	1	0	7dB
0	1	0	1	1	1	1	0	6dB
1	1	0	1	1	1	1	0	5dB
0	0	1	1	1	1	1	0	4dB
1	0	1	1	1	1	1	0	3dB
0	1	1	1	1	1	1	0	2dB
1	1	1	1	1	1	1	0	1dB
0	0	0	0	0	0	0	0	0dB
1	0	0	0	0	0	0	0	-1dB
0	1	0	0	0	0	0	0	-2dB
1	1	0	0	0	0	0	0	-3dB
0	0	1	0	0	0	0	0	-4dB
1	0	1	0	0	0	0	0	-5dB
0	1	1	0	0	0	0	0	-6dB
1	1	1	0	0	0	0	0	-7dB
0	0	0	1	0	0	0	0	-8dB
1	0	0	1	0	0	0	0	-9dB
0	1	0	1	0	0	0	0	-10dB
1	1	0	1	0	0	0	0	-11dB
0	0	1	1	0	0	0	0	-12dB
1	0	1	1	0	0	0	0	-13dB
0	1	1	1	0	0	0	0	-14dB
1	1	1	1	0	0	0	0	-15dB
0	0	0	0	1	0	0	0	-16dB
1	0	0	0	1	0	0	0	-17dB
0	1	0	0	1	0	0	0	-18dB
1	1	0	0	1	0	0	0	-19dB
0	0	1	0	1	0	0	0	-20dB
1	0	1	0	1	0	0	0	-21dB
0	1	1	0	1	0	0	0	-22dB
1	1	1	0	1	0	0	0	-23dB
0	0	0	1	1	0	0	0	-24dB
1	0	0	1	1	0	0	0	-25dB
0	1	0	1	1	0	0	0	-26dB
1	1	0	1	1	0	0	0	-27dB
0	0	1	1	1	0	0	0	-28dB
1	0	1	1	1	0	0	0	-29dB
0	1	1	1	1	0	0	0	-30dB
1	1	1	1	1	0	0	0	-31dB
0	0	0	0	0	1	0	0	-32dB
1	0	0	0	0	1	0	0	-33dB
0	1	0	0	0	1	0	0	-34dB
1	1	0	0	0	1	0	0	-35dB
0	0	1	0	0	1	0	0	-36dB
1	0	1	0	0	1	0	0	-37dB
0	1	1	0	0	1	0	0	-38dB
1	1	1	0	0	1	0	0	-39dB
0	0	0	1	0	1	0	0	-40dB
1	0	0	1	0	1	0	0	-41dB
0	1	0	1	0	1	0	0	-42dB
1	1	0	1	0	1	0	0	-43dB

LV3313PM

Volume control (-44dB to -∞)

D13	D14	D15	D16	D17	D18	D19	D20	Lch
D21	D22	D23	D24	D25	D26	D27	D28	Rch
0	0	1	1	0	1	0	0	-44dB
1	0	1	1	0	1	0	0	-45dB
0	1	1	1	0	1	0	0	-46dB
1	1	1	1	0	1	0	0	-47dB
0	0	0	0	1	1	0	0	-48dB
1	0	0	0	1	1	0	0	-49dB
0	1	0	0	1	1	0	0	-50dB
1	1	0	0	1	1	0	0	-51dB
0	0	1	0	1	1	0	0	-52dB
1	0	1	0	1	1	0	0	-53dB
0	1	1	0	1	1	0	0	-54dB
1	1	1	0	1	1	0	0	-55dB
0	0	0	1	1	1	0	0	-56dB
1	0	0	1	1	1	0	0	-57dB
0	1	0	1	1	1	0	0	-58dB
1	1	0	1	1	1	0	0	-59dB
0	0	1	1	1	1	0	0	-60dB
1	0	1	1	1	1	0	0	-61dB
0	1	1	1	1	1	0	0	-62dB
1	1	1	1	1	1	0	0	-63dB
0	0	0	0	0	0	1	0	-64dB
1	0	0	0	0	0	1	0	-65dB
0	1	0	0	0	0	1	0	-66dB
1	1	0	0	0	0	1	0	-67dB
0	0	1	0	0	0	1	0	-68dB
1	0	1	0	0	0	1	0	-69dB
0	1	1	0	0	0	1	0	-70dB
1	1	1	0	0	0	1	0	-71dB
0	0	0	1	0	0	1	0	-72dB
1	0	0	1	0	0	1	0	-73dB
0	1	0	1	0	0	1	0	-74dB
1	1	0	1	0	0	1	0	-75dB
0	0	1	1	0	0	1	0	-76dB
1	0	1	1	0	0	1	0	-77dB
0	1	1	1	0	0	1	0	-78dB
1	1	1	1	0	0	1	0	-79dB
0	0	0	0	1	0	1	0	-∞

LV3313PM

Tone block

Treble

GAIN	D29	D30	D31	D32	Lch
	D33	D34	D35	D36	Rch
0	1	1	1	1	+12dB
1	0	1	1	1	+10dB
0	0	1	1	1	+8dB
1	1	0	1	1	+6dB
0	1	0	1	1	+4dB
1	0	0	1	1	+2dB
0	0	0	0	0	0dB
1	0	0	0	0	-2dB
0	1	0	0	0	-4dB
1	1	0	0	0	-6dB
0	0	1	0	0	-8dB
1	0	1	0	0	-10dB
0	1	1	0	0	-12dB

Bass

GAIN	D37	D38	D39	D40	Lch
	D41	D42	D43	D44	Rch
0	1	1	1	1	+12dB
1	0	1	1	1	+10dB
0	0	1	1	1	+8dB
1	1	0	1	1	+6dB
0	1	0	1	1	+4dB
1	0	0	1	1	+2dB
0	0	0	0	0	0dB
1	0	0	0	0	-2dB
0	1	0	0	0	-4dB
1	1	0	0	0	-6dB
0	0	1	0	0	-8dB
1	0	1	0	0	-10dB
0	1	1	0	0	-12dB

LV3313PM

Fader block

D45	D46	D47	D48	D49	D50	LFOUT
D51	D52	D53	D54	D55	D56	LROUT
D57	D58	D59	D60	D61	D62	RFOUT
D63	D64	D65	D66	D67	D68	RROUT
0	0	0	0	0	0	0dB
1	0	0	0	0	0	-1dB
0	1	0	0	0	0	-2dB
1	1	0	0	0	0	-4dB
0	0	1	0	0	0	-6dB
1	0	1	0	0	0	-8dB
0	1	1	0	0	0	-10dB
1	1	1	0	0	0	-12dB
0	0	0	1	0	0	-14dB
1	0	0	1	0	0	-16dB
0	1	0	1	0	0	-18dB
1	1	0	1	0	0	-20dB
0	0	1	1	0	0	-30dB
1	0	1	1	0	0	-45dB
0	1	1	1	0	0	-60dB
1	1	1	1	0	0	-∞

Loudness control

D69	Operation
0	off
1	on

Zero cross control

D70	Operation
0	off
1	on

Zero cross signal detection block control

D71	Operation
0	Input gain
1	Volume

D72	Operation
0	Manual detection
1	Automatic detection

D73	D74
0	0

Zero-cross signal detection timer overflow settings

D75	D76	Operation
0	0	Timer time 10ms
1	0	Timer time 20ms
0	1	Timer time 40ms
1	1	Timer time 80ms

LV3313PM

Soft mute control

D77	Operation
0	Soft mute mode off
1	Soft mute mode on

D78	Operation
0	mute set off
1	mute set on

D79	D80	Operation
0	0	normal mode
1	0	test mode

Soft mute settling time select control

D81	D82	Operation
0	0	mute time 0.64ms
1	0	mute time 5.12ms
0	1	mute time 40ms
1	1	mute time 80ms

D83	D84	D85	D86	D87
0	0	0	0	0

Test mode block

D88	D89	D90	D91	D92	D93	D94	D95
0	0	0	0	0	0	0	0

LV3313PM

Pin Functions

Pin No.	Pin name	Function	Equivalent Circuit
36 35 34 42 43 44	L1 L2 L3 R1 R2 R3	Single end input pins.	
33 32 1 2	L4M L4P R4M R4P	Differential input pins.	
31 3	LSELO RSELO	Input selector output pins.	
30 4	LVRIN RVRIN	Main volume input pins.	
29 5	LCT RCT	Loudness function pins.	
24 10	LVROUT RVROUT	Tone output pins.	
23 11	LFIN RFIN	Fader block input pins. Drive at low impedance.	
22 21 12 13	LFOUT LROUT RFOUT RROUT	Fader output pins. Attenuation is possible separately for the front end and rear end.	

Continued on next page.

LV3313PM

Continued from preceding page.

Pin No.	Pin name	Function	Equivalent Circuit
41	Vref	Connect a capacitor of a few tens of uF between Vref and AVSS (VSS) as a 0.55 × VDD voltage generator, current ripple countermeasure.	
15	VREG	Internal logic voltage pin.	
37	VDD	Power supply pin.	
20	AVSS	Ground pin.	
38	MUTE	External muting control pin. Setting this pin to VSS level sets forcibly fader volume block to -∞ level.	
27 26 25 7 8 9	LF1C1 LF1C2 LF1C3 RF1C1 RF1C2 RF1C3	Capacitor connection pins for configuring equalizer bass band filter. Connect a capacitor between LF1C1 (RF1C1) and LF1C2 (RF1C2), and between LF1C2 (RF1C2) and LF1C3 (RF1C3).	
28 6	LF3C1 RF3C1	Capacitor connection pins for configuring equalizer treble band filter. Connect a high band compensation capacitor between LF3C1 (RF3C1) and VSS.	
17 18	CL DI	Input pin for serial data and clock used for control.	
19	CE	Chip enable pin. Data is written to the internal latch and the analog switches are operated when the level changes from High to Low. Data transfer is enabled when the level is High.	

Continued on next page.

LV3313PM

Continued from preceding page.

Pin No.	Pin name	Function	Equivalent Circuit
39	TEST	IC test pin. Normally this pin is OPEN.	
14	DV _{SS}	Logic system ground pin.	
16	OSC	External oscillat input pin. Normally this pin is OPEN.	
40	PH	Automatic zero cross detection pin.	

Usage Cautions

(1) Data Transmission at power on

- The status of internal analog switches is unstable at power on. Therefore, perform muting or some other countermeasure until the data has been set.
- At power on, initial setting data must be sent once in order to stabilize the bias of each block in a short time.

(2) Description of zero cross switching circuit operation

The LV3313PM have a function to switch zero cross comparator signal detection locations, enabling the selection of the optimum detection location for blocks whose data is to be updated. Basically, the switching noise can be minimized by inputting the signal immediately following the block whose data is to be updated to the zero cross comparator, so it is necessary to switch the detection location every time.

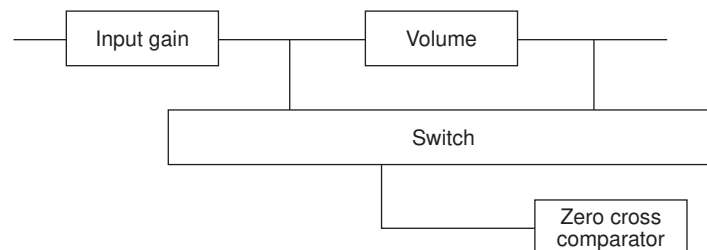

LV3313PM zero cross detection circuit

(3) Zero Cross Switching Control method

The zero cross switching control method consists of setting the zero cross control bits to the zero cross detection mode, and specifying the detection blocks before transmitting the data. These control bits are latched immediately following data transfer, that is to say beforehand in sync with the falling edge of CE, so when updating data of volumes, etc., it is possible to perform mode setting and zero cross switching with one data transfer.

(4) Soft mute operation

The LV3313PM have a soft mute function for low switching noise, when this mute function set operation. (mute/unmute function select)

The Soft mute time can be selected by send to CCB control. (0.6ms, 5ms, 40ms, 80ms)

A soft mute function can be implemented by set to soft mute on. (Set to mute on/off)

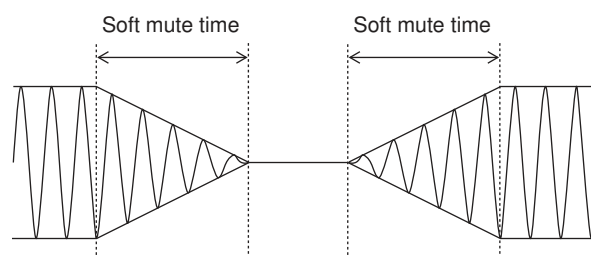

ON Semiconductor and the ON logo are registered trademarks of Semiconductor Components Industries, LLC (SCILLC). SCILLC owns the rights to a number of patents, trademarks, copyrights, trade secrets, and other intellectual property. A listing of SCILLC's product/patent coverage may be accessed at www.onsemi.com/site/pdf/Patent-Marking.pdf. SCILLC reserves the right to make changes without further notice to any products herein. SCILLC makes no warranty, representation or guarantee regarding the suitability of its products for any particular purpose, nor does SCILLC assume any liability arising out of the application or use of any product or circuit, and specifically disclaims any and all liability, including without limitation special, consequential or incidental damages. "Typical" parameters which may be provided in SCILLC data sheets and/or specifications can and do vary in different applications and actual performance may vary over time. All operating parameters, including "Typicals" must be validated for each customer application by customer's technical experts. SCILLC does not convey any license under its patent rights nor the rights of others. SCILLC products are not designed, intended, or authorized for use as components in systems intended for surgical implant into the body, or other applications intended to support or sustain life, or for any other application in which the failure of the SCILLC product could create a situation where personal injury or death may occur. Should Buyer purchase or use SCILLC products for any such unintended or unauthorized application, Buyer shall indemnify and hold SCILLC and its officers, employees, subsidiaries, affiliates, and distributors harmless against all claims, costs, damages, and expenses, and reasonable attorney fees arising out of, directly or indirectly, any claim of personal injury or death associated with such unintended or unauthorized use, even if such claim alleges that SCILLC was negligent regarding the design or manufacture of the part. SCILLC is an Equal Opportunity/Affirmative Action Employer. This literature is subject to all applicable copyright laws and is not for resale in any manner.