

**NOTE**



All numerical values are in metric units. Dimensions are in millimeters. Unless otherwise specified, dimensions have a tolerance of  $\pm 0.13$  and angles have a tolerance of  $\pm 2^\circ$ . Figures and illustrations are for identification only and are not drawn to scale.

**1. INTRODUCTION**

This specification covers the requirements for application of UPM connectors into printed circuit boards. The connectors consist of vertical receptacles, vertical headers, right-angle receptacles and right-angle headers. The connectors are available with 3~12 positions with a blade-to-blade centerline spacing of 3.0 mm. The connectors have press-fit compliant pin contacts which allow solderless pc board installation. The vertical receptacle and right-angle header have ACTION PIN\* contacts, and the vertical header and right-angle receptacle have eye-of-needle contacts. The vertical header is available with stack heights of 15 and 18 mm. The vertical receptacle features application tool slots which are designed to accept ribs of the available seating tool to aid in proper alignment when seating the vertical receptacle onto the pc board. Straight and right-angle guide pins and female guide module are available for aid in connector alignment during mating. The guide pins and guide module are available keyed or unkeyed. When corresponding with TE Connectivity Personnel, use the terminology provided in this specification to facilitate your inquiries for information. Basic terms and features of this product are provided in Figure 1.

These connectors are configured to mate with motherboard and daughter card connectors series such as Z-PACK\* FB 2mm connectors, Z-PACK HM 2mm connectors, and HDI, Eurocard, and Stripline 100 connectors.

When corresponding with TE Connectivity Personnel, use the terminology provided in this specification to facilitate your inquiries for information. Basic terms and features of this product are provided as reference Figure 1.

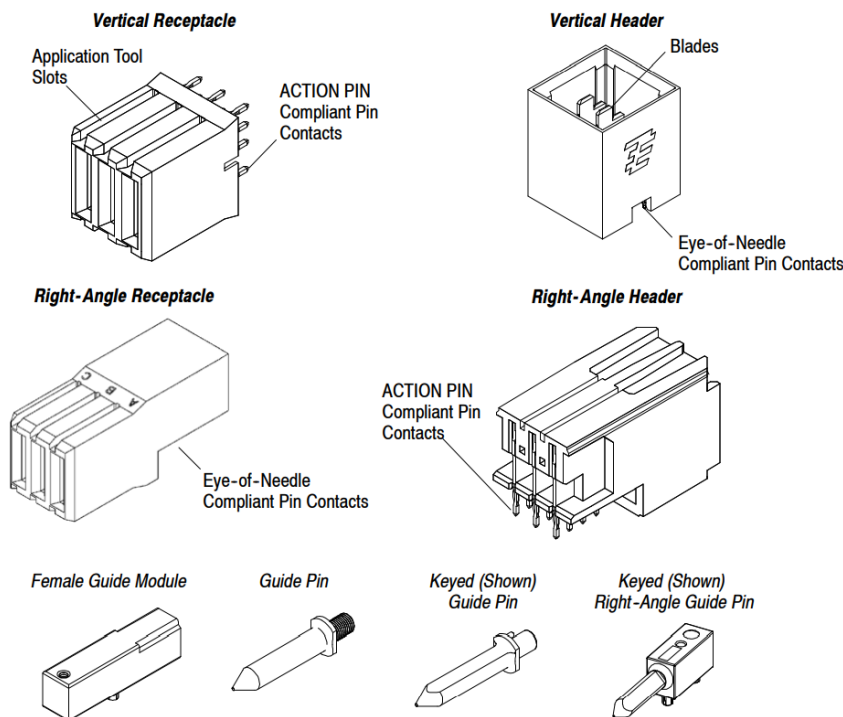

Figure 1

Figure 1 The Reference Product View of TE UPM Power Connector series

---

## 2. REFERENCE MATERIAL

### 2.1. Revision Summary

Initial release of Application Specification includes:

Updated document to corporate requirements.

### 2.2. Customer Assistance

Reference Product Part Number in product code 1080 are representative of TE UPM Power Connector series.

TE P/N: 5223968-1 UPM R/A Header 3P STD Power Connector, LMM.

TE P/N: 5-5223968-1 UPM R/A Header 3P HC Power Connector, LMM.

TE P/N: 5223955-2 UPM Vertical Rec 3P STD Power Connector.

TE P/N: 5-5223955-2 UPM Vertical Rec 3P HC Power Connector.

TE P/N: 1645498-1 UPM Vertical Header 3P HC Power Connector.

TE P/N: 120943-1 UPM R/A Rec 3P HC Power Connector.

Use of these numbers will identify the product line and help you to obtain product and tooling information. Such information can be obtained through a local Representative, by visiting our website at [www.te.com](http://www.te.com), or by calling PRODUCT INFORMATION at the numbers at the bottom of page 1.

### 2.3. Drawings

Customer Drawings for product part numbers are available from the service network. If there is a conflict between the information contained in the Customer Drawings and this specification or with any other technical documentation supplied, the information contained in the Customer Drawings takes priority.

### 2.4. Specifications

Production Specification as below provide expected product performance and test information.

108-1651 Product Specification of TE UPM Power Connector

501-461 Qualification Test Report of TE UPM Power Connector

### 2.5. Instructional Material

Instruction Sheets (408--series) provide product assembly instructions or tooling setup and operation procedures. Documents available which pertain to this product are:

408-4169 Seating Tool 224421-[ ] for UPM Receptacles with ACTION PIN Contacts

408-4280 Seating Tool 224441-1 and Support Anvil 224442-1 for UPM Connectors

408-4315 Seating Tool 224440-1 and Board Support Anvil 217603-1

408-6923 Manual Arbor Frame Assembly 58024-1

408-7777 Manual Arbor Frame Assembly 91085-2

### 2.6. Standards

- EIA-364: Electrical Connector/Socket Test Procedures Including Environmental Classifications
- 109-197: Test Specification (TE Connectivity Test Specification vs EIA Test Methods)

### 3. REQUIREMENTS

#### 3.1. Safety

Do not stack product shipping containers so high that the containers buckle or deform.

#### 3.2. Material

The insulation housing is made of thermoplastics, flammability class UL94 V-0, and the contacts are made of high conductivity copper alloy, with gold plating, or gold plating plus Pd/Ni over nickel base-plated at product contact area, the compliant pin section of the contact is plated with tin plating over nickel based-plating. Detail please refer to the customer drawing.

#### 3.3. Storage

##### A. Ultraviolet Light

Prolonged exposure to ultraviolet light may deteriorate the chemical composition used in the cable connector material.

##### B. Shelf Life

The connector or components should remain in the shipping containers until ready for use to prevent deformation to the contacts. The connector or components should be used on a first in, first out basis to avoid storage contamination that could adversely affect performance.

##### C. Chemical Exposure

Do not store connector or components near any chemical listed below as they may cause stress corrosion cracking in the contacts.

Alkalis	Ammonia	Citrates	Phosphates	Citrates	Sulfur Compounds
Amines	Carbonates	Nitrites	Sulfur Nitrites		Tartrates

#### 3.4. Sequence Options

Three different levels of sequencing are available: Level 1, Level 2, and Level 3. S/M/L. It is recommended that Level 3 be used in conjunction with either a rack system or a guide pin and/or guide module arrangement. See Figure 2.

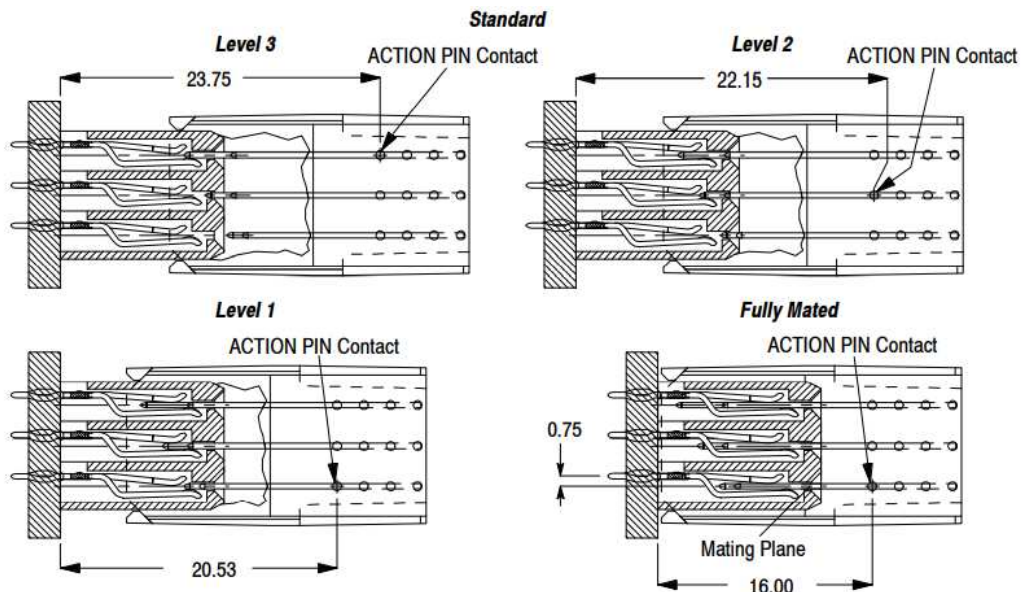

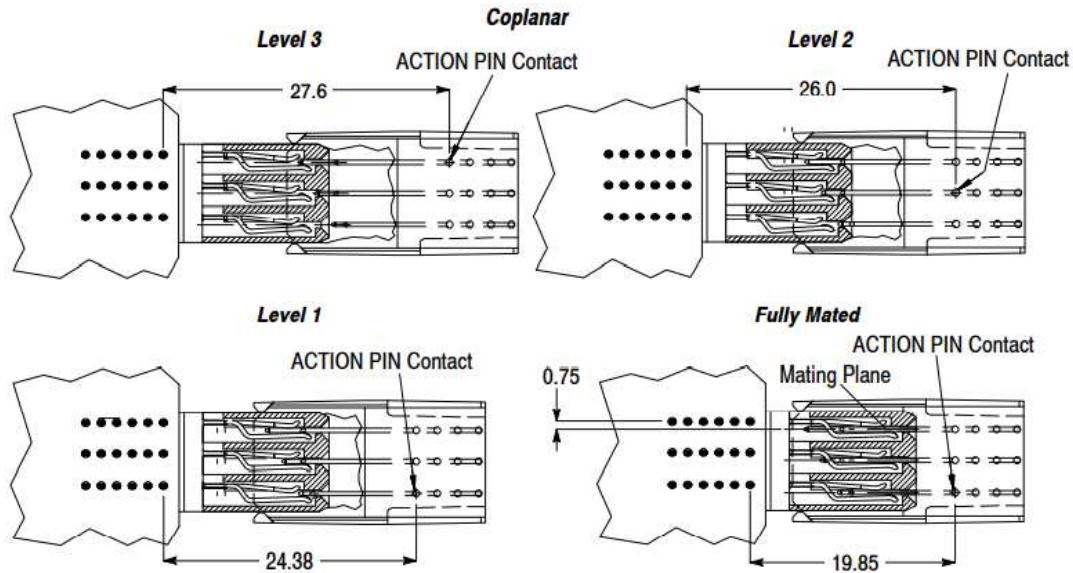

Figure 2

### 3.5. Recommended PCB

#### A. Material and Thickness

The pc board material shall be glass epoxy (FR--4). The minimum pc board thickness for vertical headers with eye--of--needle contacts and right--angle receptacles shall be 1.4 mm. The minimum pc board thickness for vertical receptacles with ACTION PIN contacts shall be 1.8 mm. The minimum pc board thickness for right--angle headers with ACTION PIN contacts shall be 1.4 mm.



For applications requiring the minimum installation force for the connector, the pc board through-hole size should be in the high end of the allowable tolerance.

#### B. Contact Hole Configuration

The contact holes must be drilled and plated through to the dimensions specified in Figure 3.

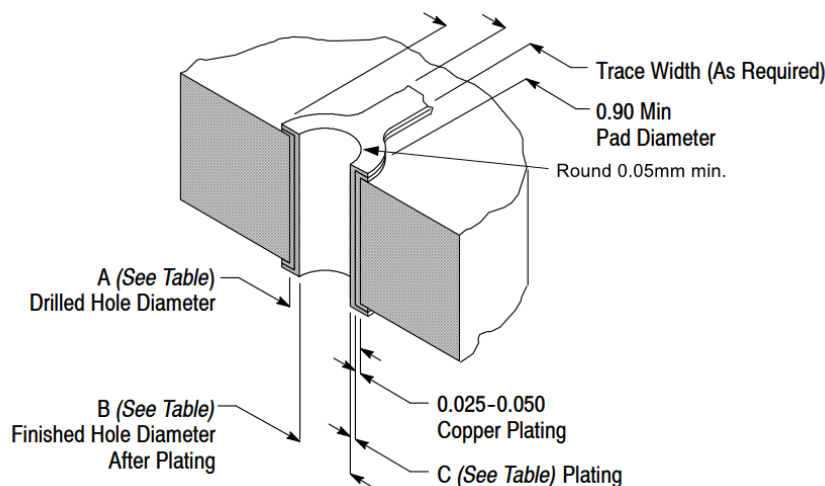

DIMENSION			
A	B	C	
		Surface Finish	Thickness
0.70 (±0.02mm)	0 61 Nominal (±0.05mm)	Hot Air Solder Leveling (HASL) Tin--Lead (SnPb)	0.004-0.0150
		Immersion Tin (Sn)	0.0005-0.0040
		Organic Solderability Preservative (OSP)	0.0002-0.0005
		Immersion Silver (Ag)	0.0001-0.0005
0.73 (±0.02mm)	0 64 Nominal (±0.05mm)	Immersion Gold (Au) Over Nickel (Ni) (ENIG)	0.00127-0.0076

Figure 3.

### C. Circuit Pattern Layout

The layout for the placement of connectors is provided in Figure 4.



The contact times of the vertical receptacle and right-angle receptacle are arranged so that the connector can only be placed on the pc board in one orientation.

### Recommended Motherboard Layout

Component side of daughter card  
(Row "B" of 2mmHM & HM Zd connectors)

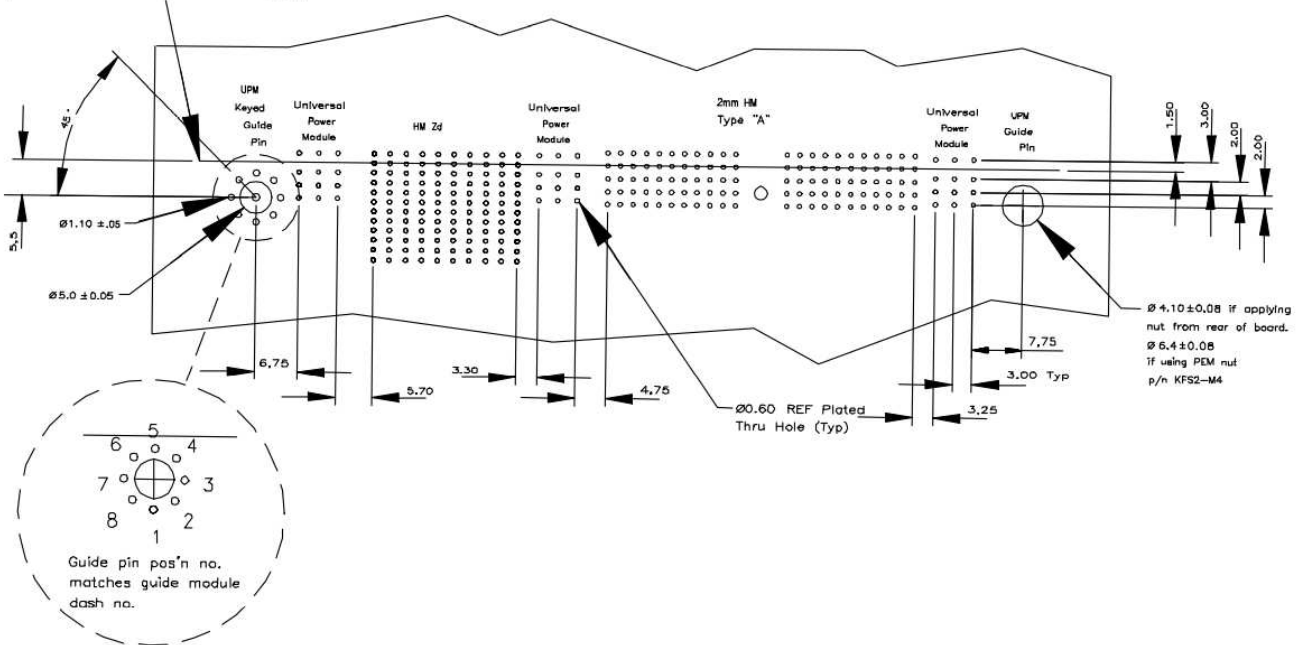

**Recommended Daughter Card Layout**

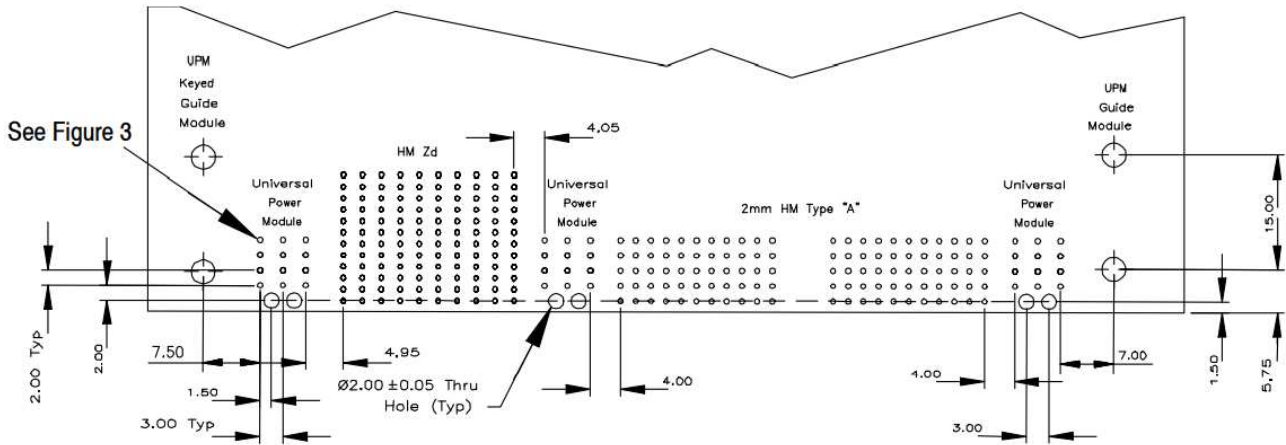

Figure 4.

**3.6. End-to-End and Side-by-Side Placement:**

The ends of the right-angle receptacle housing are a maximum of 3.0 mm from the centerlines of the first and third blades. As shown in Figure 5, this allows the hole pattern for these blades to be 4.0 mm from the hole pattern of the Z-PACK HM 2mm connector. For side-by-side placement, a 12.0 mm centerline spacing can be used. For requirements of other connectors, call PRODUCT INFORMATION at the number at the bottom of page 1.

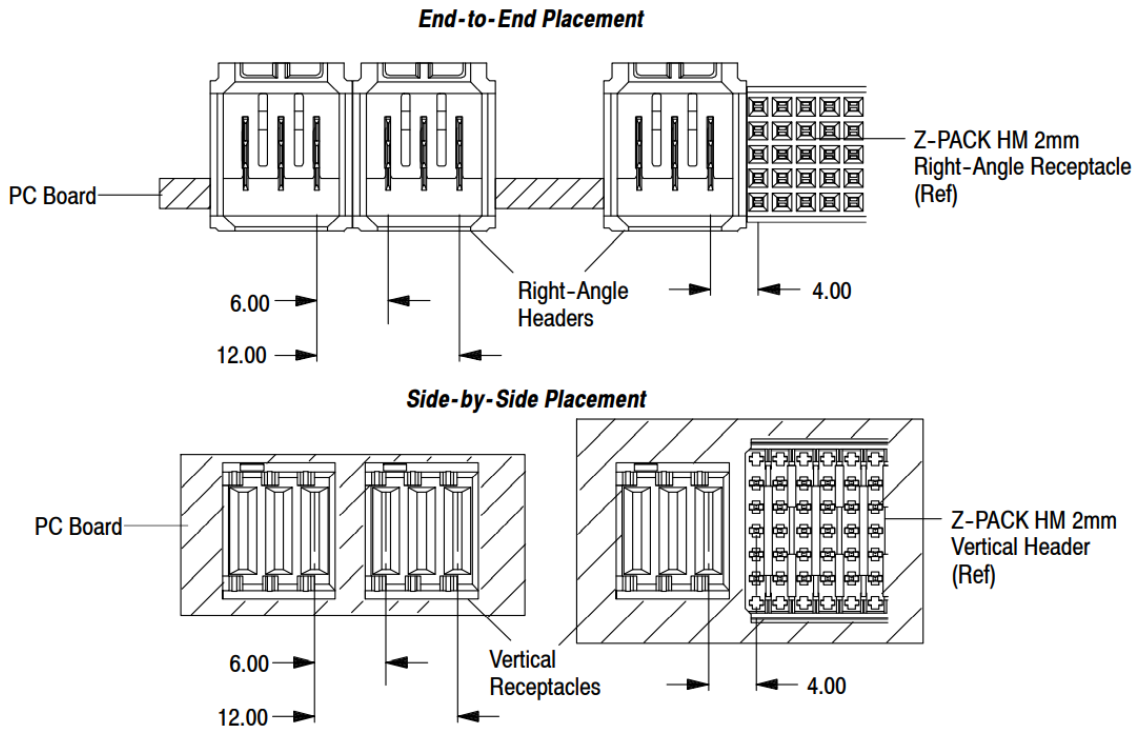

Figure 5.

### 3.7. Seating Connectors

#### A. Handling and Initial Positioning

The connectors should be gripped by the housing only-not by the contacts. When placing a connector onto the pc board, all contact tines should be aligned and inserted into the pc board simultaneously to prevent twisting or bending of the contacts.

#### B. Force.

When seating a connector, the force must be applied evenly on the connector to prevent deformation or other damage to the contacts and housing. When seating receptacles, force must be simultaneously applied to the shoulders of each contact at the bottom of the slots on the exterior or the housing. When seating headers, force must be evenly applied to the back, top surface of the housing. The maximum force required to seat the connectors is given in Figure 6.

Connector Tail Type	Press Force into PTH
ACTION PIN	30N ref per Action Pin, 89N Max.
Eye-of-Needle	30N ref per Action Pin, 89N Max.

Figure 6.

#### C. Height.

The seating height (measured from the top of the seating tool or flat rock to the top of the pc board) must meet the dimension shown in Figure 7.

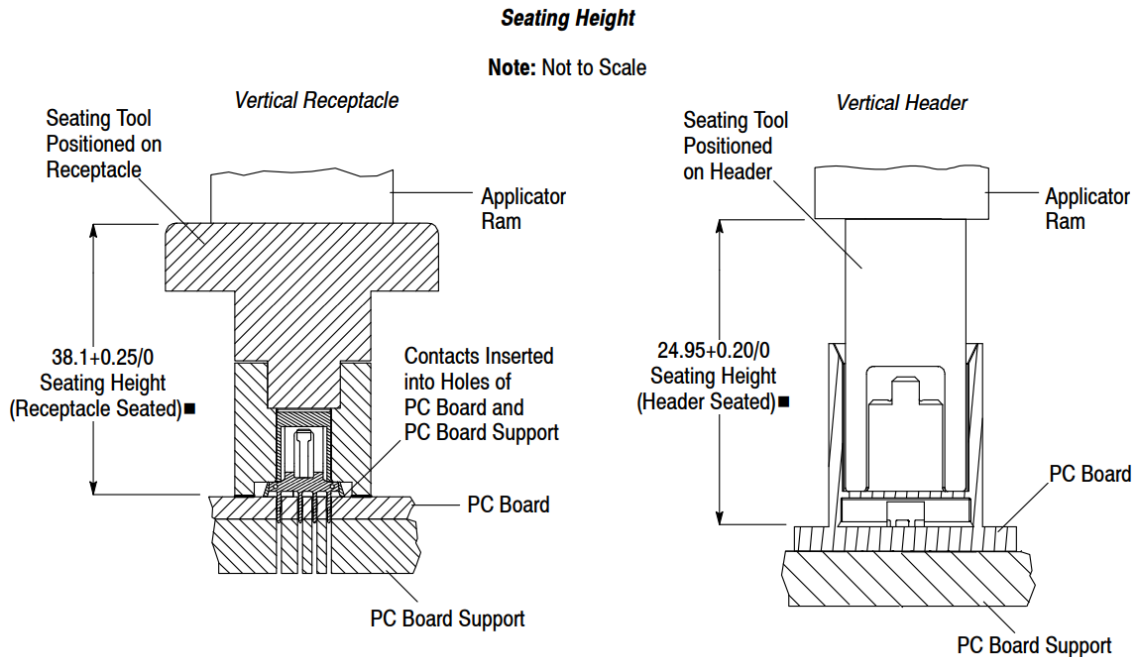

*Right-Angle Receptacle and Right-Angle Header*

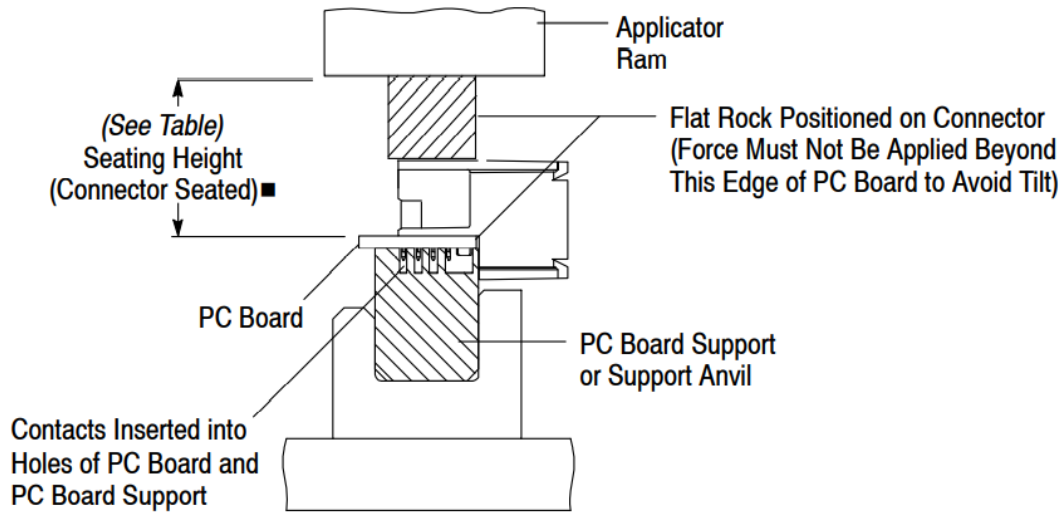

Header	Height of Flat Rock + 9.70+0.20/0
Receptacle	Height of Flat Rock + 7.67+0.20/0

- 0.10 (Max) Gap Allowed Between Housing and PC Board - This Applies to All Connectors

*Figure 7*

**D. System misalignment.**

The steel guide module is recommended to assemble with system backboard application, to improve the misalignment capability, and anti-vibration performance. The tolerance between guide pin and guide socket module, is always recommended to be  $\pm 0.25\text{mm}$  ref. TE P/N: 223969-1, Stainless steel guide pin, and TE P/N: 5223957-3 Guide socket module (Mating screw 1410946-1/-2/-3, M3 screw).



*Figure 8. Reference Guide pin and Guide Socket Module View.*

**3.8. Installing Guide Pin and Guide Module**

The guide pin must be secured to the pc board using a customer--supplied screw. The female guide module must be seated using a press force of approximately 890N ref. into PCB Drilled hole, then secured using a customer-supplied screw. Recommended maximum torque for each screw is 1.01 N-m [9 in.-lbs]. See Figure 6.



The press force of guide socket module could be adjusted in accordance with different application, by adjusting PCB drilled hole diameter.

**Installing Guide Pin and Guide Module**

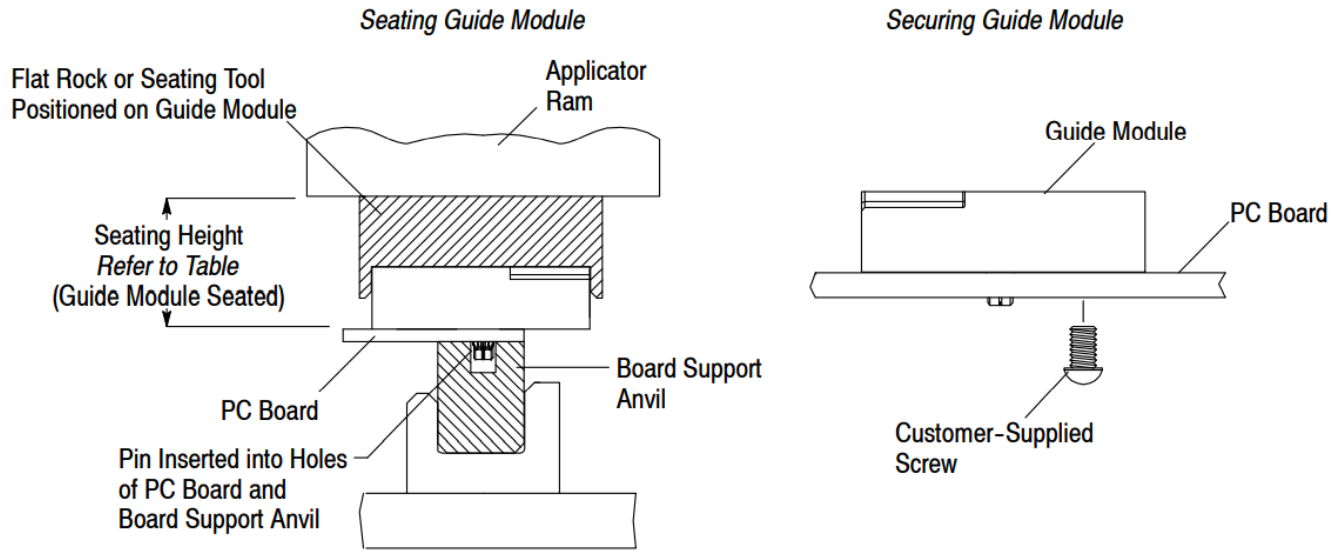

When Using Flat Rock	9.70+0.20/0
When Using Seating Tool	20.7+0.25/0

**Guide Pin and Guide Module Installed**

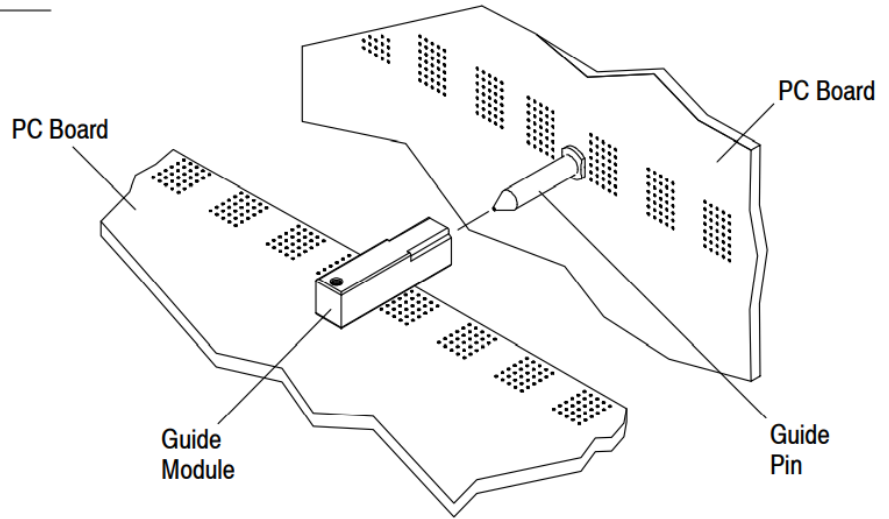

Figure 9.

### 3.9. Cleaning and Drying Assemblies

#### A. Cleaning.

These connectors are chemically resistant to most standard cleaning fluids used in the electronics industry. Cleaners compatible with these connectors when applied for the times and temperatures listed are given in Figure 9.



*To avoid personal injury, strict attention must be given to the recommendations of the solvent manufacturer regarding toxicity and other safety requirements. Refer to the manufacturer's Material Safety Data Sheet (MSDS) for characteristics and handling of cleaners.*

CLEANER		TIME (Minutes)	TEMPERATURE (Maximum)
NAME	TYPE		
ALPHA 2110	Aqueous	1	132°C [270°F]
BIOACT EC-7	Solvent	5	100°C [212°F]
Butyl CARBITOL Solvent	Solvent	1	Ambient Room
Isopropyl Alcohol	Solvent	5	100°C [212°F]
KESTER 5778	Aqueous	5	100°C [212°F]
KESTER 5779	Aqueous	5	100°C [212°F]
LONCOTERGE 520	Aqueous	5	100°C [212°F]
LONCOTERGE 530	Aqueous	5	100°C [212°F]
Terpene Solvent	Solvent	5	100°C [212°F]

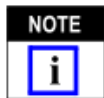

For information on cleaning solvents not listed, contact PRODUCT INFORMATION at the number at the bottom of page 1.

#### B. Drying.

When drying cleaned assemblies, DO NOT exceed the temperature limitation of -55 to 125°C [-67 to 257° F]. Excessive temperatures may cause housing degradation.

### 3.10. Mating Connectors

#### A. Alignment

Proper alignment is essential to ensure full engagement of mating connectors and to ensure the contacts are not bent or otherwise damaged during mating and unmating. Alignment tolerances are shown in Figure 10.

**Alignment When Mating Connectors**

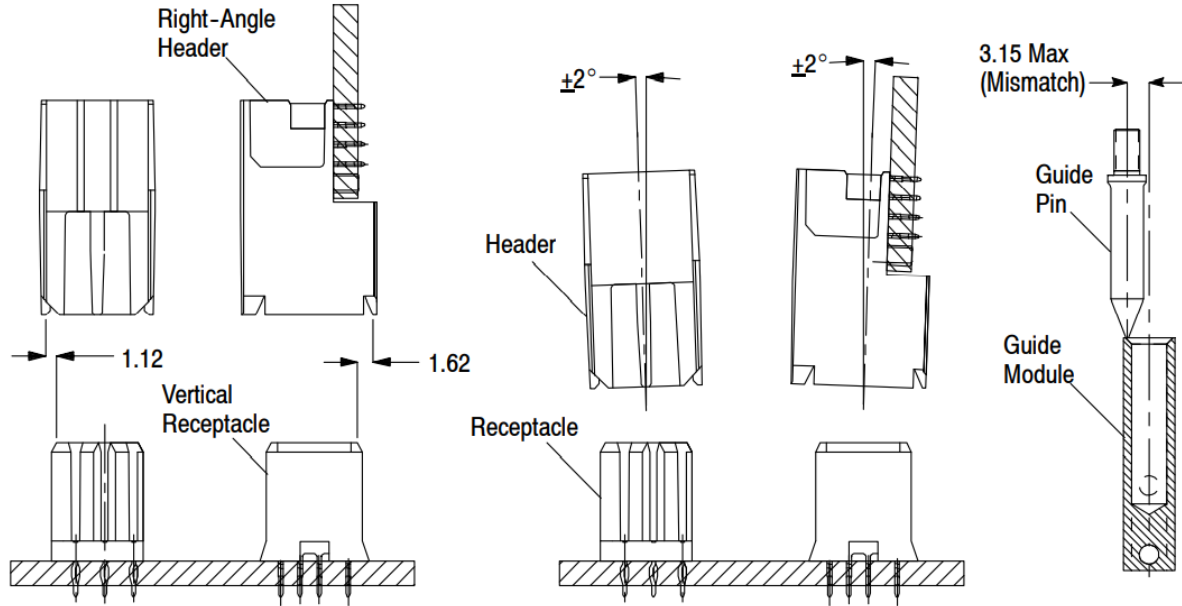

**B. Mating Dimensions.**

Full mating of the connectors is necessary to ensure a good connection. Mating dimensions should be as shown in Figure 11.

**Mating Dimensions**

**Right-Angle Header to Vertical Receptacle**

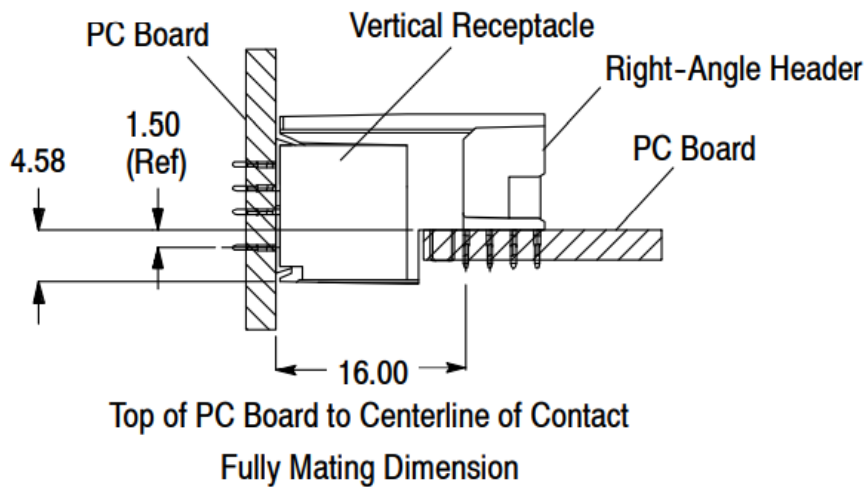

*Right-Angle Header to Right-Angle Receptacle*

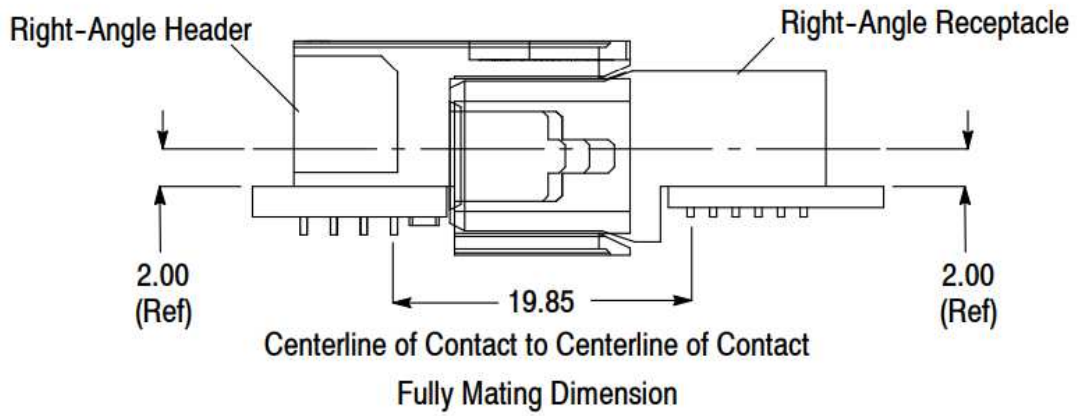

*Vertical Receptacle to Vertical Header*

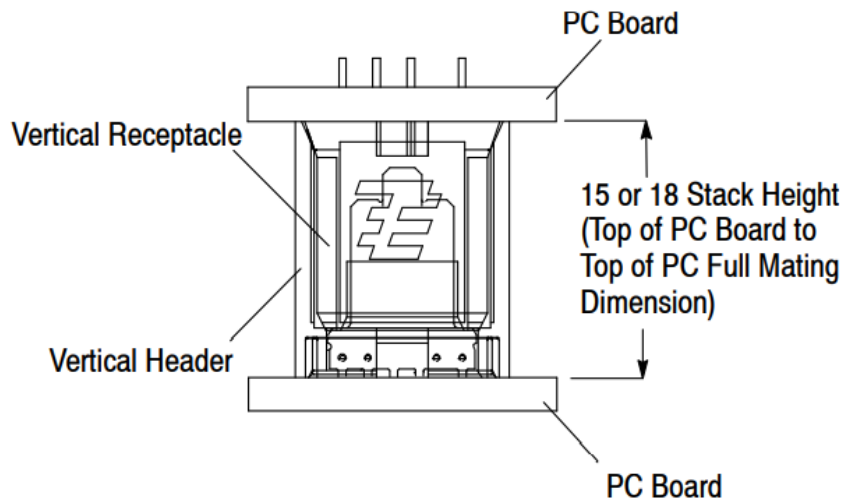

**3.11. Repair**

Damaged contacts cannot be removed from the connector. The entire connector must be removed from the pc board and replaced with a new one.

### 3.12. Removal

When removing connectors, the pc board must be placed on a board support that provides support all around the housing of the connector to be removed. The board support must not interfere with or damage any other components on the pc board. An even force must be applied to all contact pins with a flat rock and press capable of applying 800 N [180 lb] REF. See below Figure. Connectors must not be re-used after being removed from the pc board.

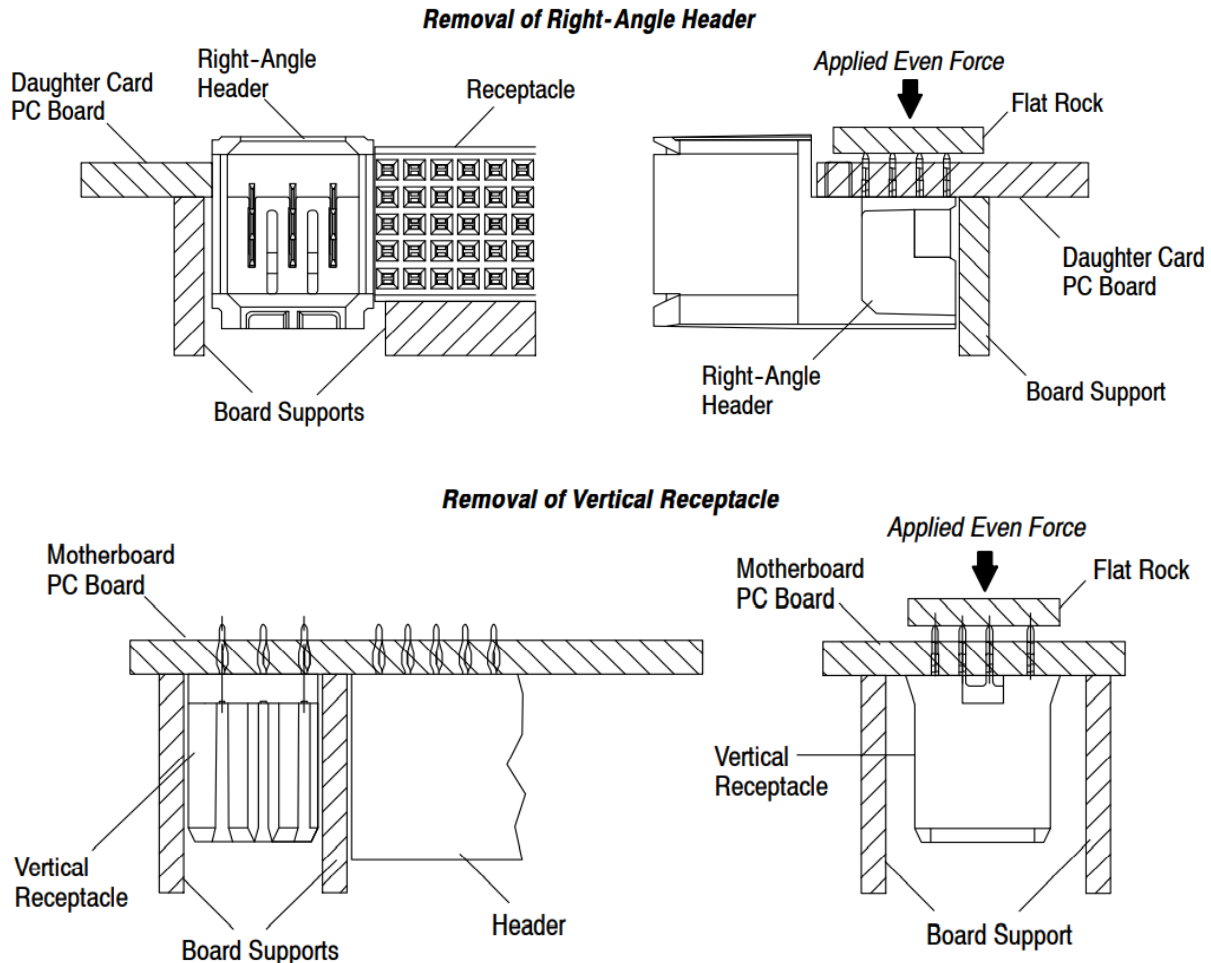

## 4. QUALIFICATION

UPM connectors are Component Recognized by Underwriters Laboratories Inc. (UL) and CSA International in File E28476 and Component Recognized by UL and CSA International for AC current interruption. UPM connectors have successfully met the requirements given in the following documents released by the International Electrotechnical Commission (IEC) and Telcordia. IEC 61076--4, "Connectors with Assessed Quality for Use in D.C., Low--Frequency Analogue and in Digital High--Speed Data Applications — Part 4: Sectional Specification for Printed Board Connectors" Telcordia GR--1217--Core, "Generic Requirements for Separable Electrical Connectors Used in Telecommunications Hardware"

## 5. TOOLING

Tooling part numbers and instructional material packaged with the tooling are shown in Figure 13.

### 5.1. Robotic Equipment

Robotic equipment for placement of connectors on a pc board must have a true position accuracy of 0.13 mm to ensure proper location and insertion of the contact pins. This includes gripper and fixture tolerances as well as equipment repeatability. It must use the connector datum surface to ensure reliable connector placement.



For assistance in setting up prototype or production line equipment, contact your local Representative or call the TOOLING ASSISTANCE CENTER at the number at the bottom of page 1

### 5.2. Manual Arbor Frame

The available manual arbor frames are capable of supplying the required force needed to seat and remove the connectors using a seating tool or flat rock and pc board support.

### 5.3. Seating Tool

The seating tool is used to provide a surface to accept the force required to seat a vertical receptacle or guide module. For the vertical receptacle, the seating tool is designed to allow pressure to be applied evenly on the contact shoulders and prevent the pins from being pushed out of the housing.

### 5.4. PC Board Support

A pc board support must be used to prevent bowing of the pc board during seating of the connectors. It should have a flat surface with holes or a channel large enough to receive the contact pins.

### 5.5. Flat Rock and Housing Support

Commercially-available bar stock with a flat surface large enough to cover the top surface of a right-angle header or right-angle receptacle can be used as a flat rock to seat it onto the pc board. The flat rock can also be used to remove a connector from the pc board by pressing evenly on the end of the contact pins.

When removing a right--angle receptacle from the pc board, a housing support with sides and ends as close as possible to the size of the housing is recommended.

Connectors must not be re--used after being removed from the pc board.

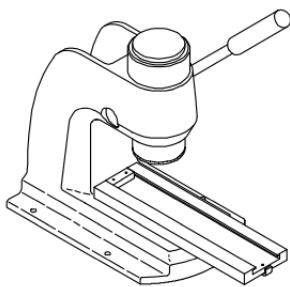

Manual Arbor Frame Assembly 91085-2 (408-7777)

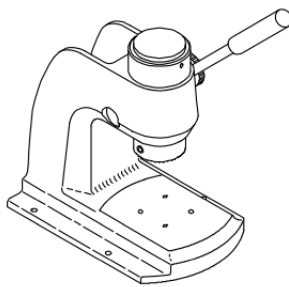

Manual Arbor Frame Assembly 58024-1 (408-6923)

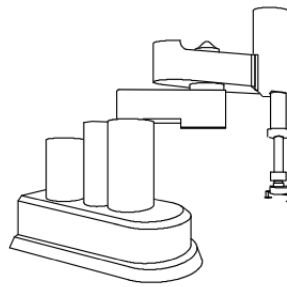

Robotic Equipment (Designed Upon Request)

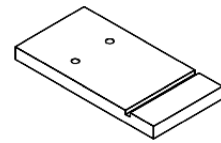

PC Board Support (Must Be Custom Made)

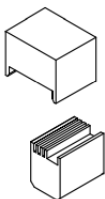

Seating Tool 224441-1 and Support Anvil 224442-1 (408-4280)

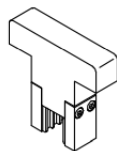

Seating Tool 224421-[] for UPM Receptacles with ACTION PIN Contacts (408-4169)

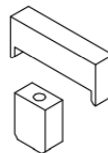

Seating Tool 224440-1 and Board Support Anvil 217603-1 (408-4315)

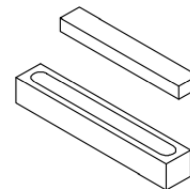

Flat Rock and Housing Support (Customer Supplied)

**Detail A**  
**Seating Tool for Vertical Header**

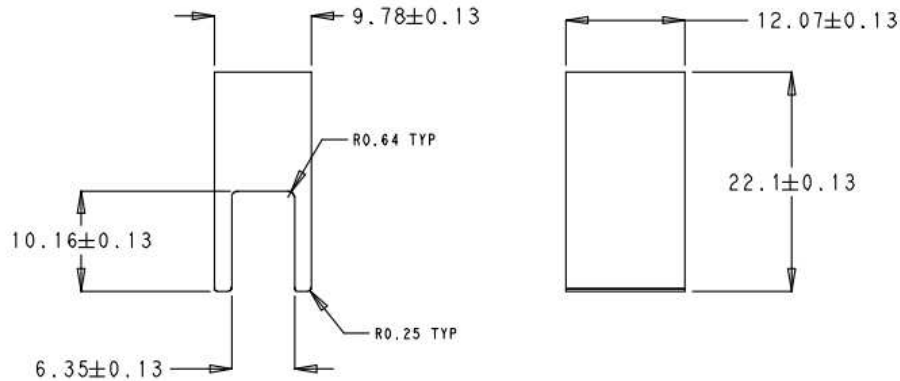

CONNECTOR	SEATING TOOL	PC BOARD SUPPORT	ARBOR FRAME ASSEMBLY
Vertical Receptacle	224421-[]	217602-1	91085-2 or 58024-1
Right-Angle Receptacle	Flat Rock (Customer-Supplied)	Customer-Supplied Using PC Board Footprint for Connector	
Vertical Header	Connector-Specific Designed Seating Tool (Customer-Supplied) (See Detail A)	Customer-Supplied Using PC Board Footprint for Connector	
Right-Angle Header	Flat Rock (Customer-Supplied) or Seating Tool 224441-1	Customer-Supplied Using PC Board Footprint for Connector or Support Anvil 224442-1	
Guide Module	Flat Rock (Customer-Supplied) or Seating Tool 224440-1	217603-1	

## 6. VISUAL AID

The illustration below shows a typical application of UPM connectors. This illustration should be used by production personnel to ensure a correctly applied product. Applications which DO NOT appear correct should be inspected using the information in the preceding pages of this specification and in the instructional material shipped with the product or tooling.

