

REVISIONS			
REV	DESCRIPTION, ECN, EAR NO.	DATE	APP'D
G	PRODUCT DRAWING (EAR 15057)	FEB2/22	K.L.
H	PRODUCT DRAWING (EAR 15057)	FEB14/22	K.L.

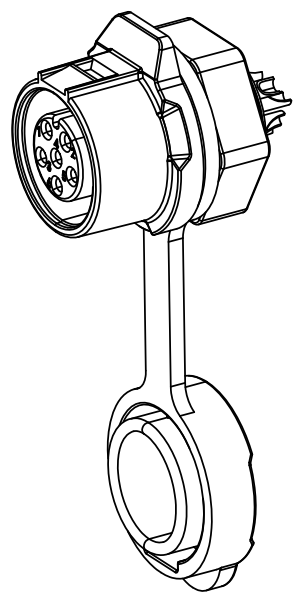

**FEMALE WITH SOCKET CONTACT**

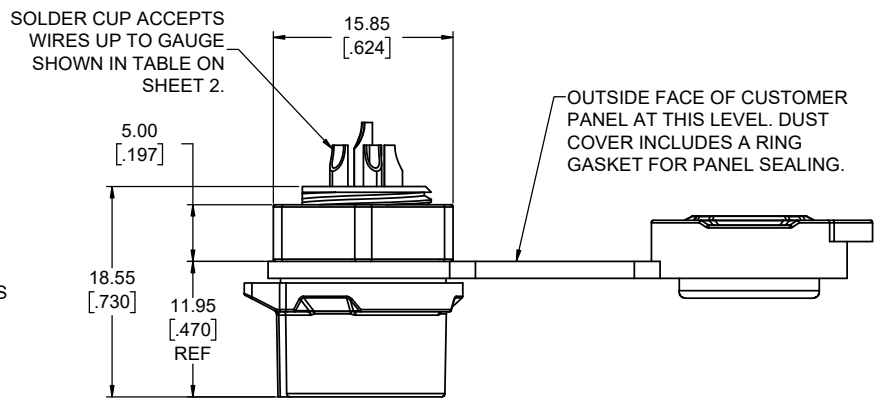
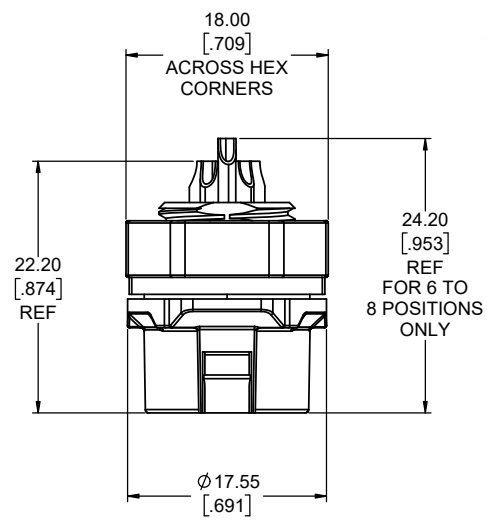
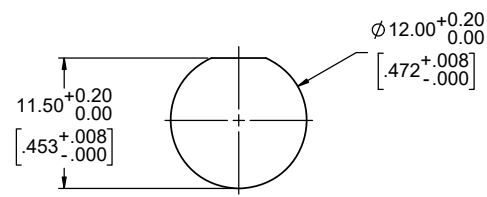

**RECOMMENDED PANEL CUTOUT**

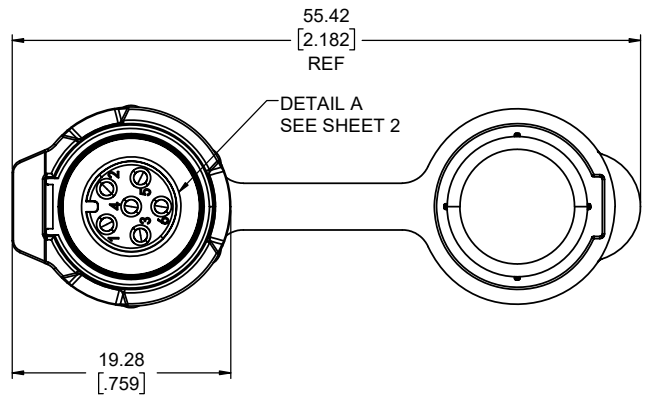

**NOTES:**

- ALL MATERIALS TO BE RoHS COMPLIANT PER EU DIRECTIVE 2011/65/EU AND AMENDMENTS.
  - HOUSINGS & HEX NUT: THERMOPLASTIC PBT, UL FLAMMABILITY RATING 94V-0, OUTDOOR RATING F1, BLACK
  - CONTACTS: COPPER ALLOY, GOLD OVER NICKEL PLATED.
  - DUST COVER: SILICONE RUBBER
- ENVIRONMENTAL PROTECTION: IP67 PER IEC 60529 IN MATED CONDITION.
- OPERATING TEMPERATURE: -40°C TO +80°C
- SEE TABLE ON SHEET 2 FOR ADDITIONAL CHARACTERISTICS.
- RECOMMENDED PANEL THICKNESS: 2.0mm (.08") TO 3.0mm (.12").
- FOR A 3 POSITION SIZE WITH PIN CONTACTS, REFER TO DRAWING P-MRD-AJ03-L13-000.

**ORDERING CODE: MRD-AH0X-L13-000**

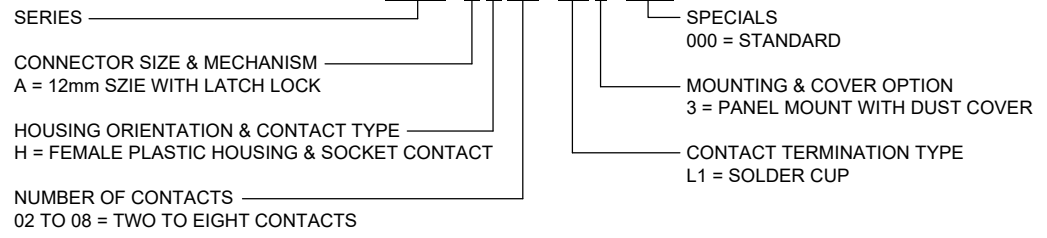

UNLESS SPECIFIED OTHERWISE	DRAWN	K.XIONG	MAY9/18
PRIMARY UNITS MILLIMETERS	CHECKED	K.LAMBIE	MAY15/18
SECONDARY UNITS INCHES	M.E. APP'D		
REFERENCE IN PARENTHESSES	Q.A. APP'D		
GENERAL TOLERANCES	DWG APPR.	A.GREEN	MAY15/18
1 DECIMAL PLACE	ENG. REL. NO.	EAR 14575	
2 DECIMAL PLACES ±0.25	REF.		
3 DECIMAL PLACES	THIRD ANGLE PROJECTION		
ANGULAR DEGREES	DO NOT SCALE DRAWING		

**Amphenol Canada Corp.**  
Commercial Products

**MRD SERIES RUGGED PANEL MOUNT CONNECTOR, FEMALE WITH 2-8 SOCKET CONTACTS, LATCH LOCK, DUST COVER, IP67 RATING, RoHS COMPLIANT**

DWG. NO. **P-MRD-AH0X-L13-000** REV **H**

CODE ID NO. 03554 DWG SIZE: X SCALE: 3:1 SHEET 1 OF 2

REVISIONS			
REV	DESCRIPTION, ECN, EAR NO.	DATE	APP'D
G	PRODUCT DRAWING (EAR 15057)	FEB2/22	K.L.
H	PRODUCT DRAWING (EAR 15057)	FEB14/22	K.L.

**END VIEWS FOR CONTACT MATING AREA**

DETAIL A VIEW (SCALE 4:1)							
NUMBER OF CONTACTS	2	3	4	5	6	7	8

**PART NUMBER CHARACTERISTICS TABLE**

CONNECTOR PART NUMBER	MAX WIRE GAUGE	CURRENT RATING	VOLTAGE RATING	CONTACT RESISTANCE	DWV
MRD-AH02-L13-000	20 AWG	5A	125V AC MAX	10.0mΩ MAXIMUM	1500 VDC
MRD-AH03-L13-000					
MRD-AH04-L13-000					
MRD-AH05-L13-000					
MRD-AH06-L13-000					
MRD-AH07-L13-000	22 AWG	3A	100V AC MAX		
MRD-AH08-L13-000					



UNLESS SPECIFIED OTHERWISE	DRAWN	K.XIONG	MAY9/18
PRIMARY UNITS MILLIMETERS	CHECKED	K.LAMBIE	MAY15/18
SECONDARY INCHES	M.E. APP'D		
REFERENCE IN PARENTHESES	Q.A. APP'D		
GENERAL TOLERANCES	DWG APPR.	A.GREEN	MAY15/18
1 DECIMAL PLACE	ENG. REL. NO.	EAR 14575	
2 DECIMAL PLACES ±0.25	REF.		
3 DECIMAL PLACES	THIRD ANGLE PROJECTION		DO NOT SCALE DRAWING
ANGULAR DEGREES			

**Amphenol Canada Corp.**  
Commercial Products

**MRD SERIES RUGGED PANEL MOUNT CONNECTOR, FEMALE WITH 2-8 SOCKET CONTACTS, LATCH LOCK, DUST COVER, IP67 RATING, RoHS COMPLIANT**

DWG. NO. **P-MRD-AH0X-L13-000** REV **H**

CODE ID NO. 03554 | DWG SIZE: X | SCALE: 4:1 | SHEET 2 OF 2