

STRAIGHT SQUARE FLANGE JACK

R143.258.000

CLAMP TYPE - CABLE 5/50 S+D

Series : TNC

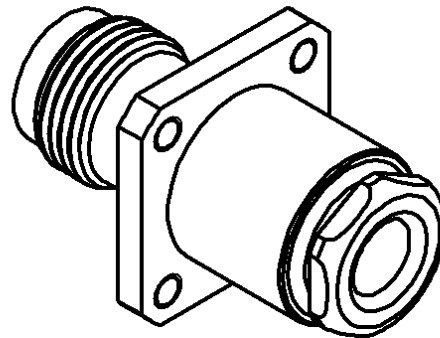
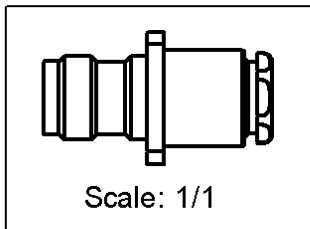
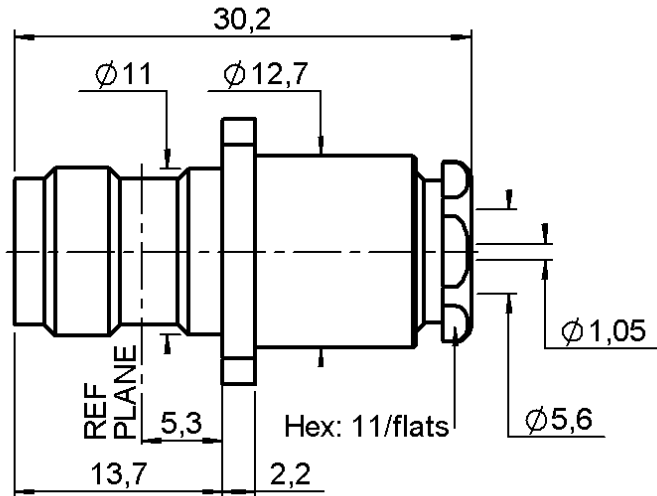
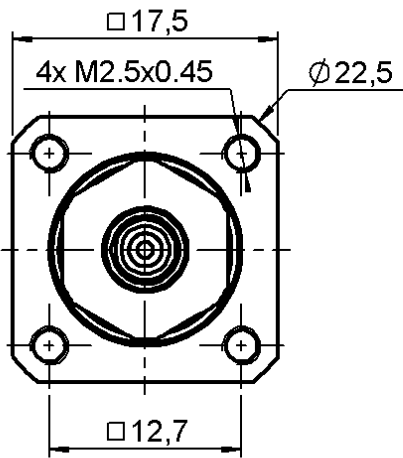

PANEL CUT OUT

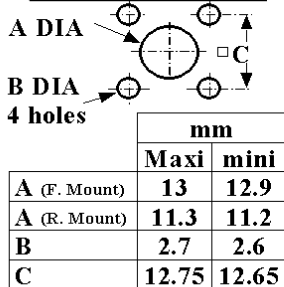

All dimensions are in mm.



COMPONENTS	MATERIALS	PLATINGS (µm)
BODY	BRASS	NICKEL 2
CENTER CONTACT	BERYLLIUM COPPER	GOLD 0.5 OVER NICKEL 2
OUTER CONTACT	-	-
INSULATOR	PTFE	-
GASKET	SILICONE RUBBER	-
OTHERS PARTS	BRASS	NICKEL 2
-	-	-
-	-	-

Issue : 0417 K

In the effort to improve our products, we reserve the right to make changes judged to be necessary.



STRAIGHT SQUARE FLANGE JACK

R143.258.000

CLAMP TYPE - CABLE 5/50 S+D

Series : TNC

PACKAGING

Standard	Unit	Other
1	-	Contact us

SPECIFICATION

ELECTRICAL CHARACTERISTICS

Impedance		50	Ω
Frequency		0-11	GHz
VSWR	1.30 +	0.000	x F(GHz) Maxi
Insertion loss		0.06	\sqrt{F} (GHz) dB Maxi
RF leakage	- (57	- F(GHz)) dB Maxi
Voltage rating		500	Veff Maxi
Dielectric withstanding voltage		1500	Veff mini
Insulation resistance		5000	M Ω mini

CABLE ASSEMBLY

Stripping	a	b	c	d	e	f
mm	2.50	5.00	0.00	0.00	1.50	0.00

Assembly instruction : **Clamp 02**

Recommended cable(s)

RG 223
RG 142
RG 400
KX 23
RG 142 FTX
RG 58
KX 15
RG 141

Cable retention

- pull off **180** N mini
- torque **NA** N.cm

MECHANICAL CHARACTERISTICS

Center contact retention			
Axial force – Mating end		NA	N mini
Axial force – Opposite end		NA	N mini
Torque		NA	N.cm mini

TOOLING

Part Number	Description	Hexagon
.	.	.

Recommended torque			
Mating		NA	N.cm
Panel nut		NA	N.cm
Clamp nut		450	N.cm
A/F clamp nut		11.000	mm

OTHERS CHARACTERISTICS

Mating life		500	Cycles mini
Weight		19.040	g

ENVIRONMENTAL

Operating temperature		-65/+165	$^{\circ}$ C
Hermetic seal		NA	Atm.cm3/s
Panel leakage		NA	

Issue : 0417 K

In the effort to improve our products, we reserve the right to make changes judged to be necessary.

