

REVISIONS					
P	LTR	DESCRIPTION	DATE	DWN	APVD
B3		REVISED PER ECR-23-180706	19JUL2023	LP	MY

SPECIFICATIONS:

MATERIALS:

CASE, PPS, UL94 V-0, BROWN
 ACTUATOR, NYLON, UL94V-0, SEE P/N TABLE FOR FINISH
 COVER, STEEL, TIN FINISH
 TERMINAL/FIXED CONTACT, COPPER ALLOY-SILVER FINISH
 MOVING CONTACT, STAINLESS STEEL-SILVER FINISH

ELECTRICAL:

MAX CONTACT RATING, 50MILLIAMPER@24V DC
 MIN CONTACT RATING, 1MICROAMP@1V DC
 CONTACT RESISTANCE, 100 MILLIOHMS MAX
 INSULATION RESISTANCE, 100 MEGOHM MIN.
 DIELECTRIC STRENGTH, 500 V AC FOR 1 MINUTE
 LIFE EXPECTANCY, 1,000,000 CYCLES

MECHANICAL:

ACTUATION FORCE, SEE P/N TABLE
 ACTUATION TRAVEL, 0.25 +0.20/-0.10
 LIFE EXPECTANCY, 1,000,000,
 (2 CYCLES PER SECOND AND 150% ACTUATION FORCE)

ENVIRONMENTAL:

OPERATING TEMPERATURE, -40 TO +105° C
 STORAGE TEMPERATURE, -40 TO +105° C
 SOLDERABILITY, EIA-RS-186-9E, OR MIL-STD-202F
 RESISTANCE TO SOLDER HEAT, 260° C FOR 10SEC-PER 109-201, COND B
 1. NO CHANGE IN INITIAL ELECTRICAL AND MECHANICAL CHARACTERISTICS

NOTES:

- TAPE AND REEL PACKAGING PER EIA 481.
- ALL MATERIALS AND FINISHES SHALL COMPLY WITH EU DIRECTIVE 2002/95/EC OF 27JAN2003 (ROHS)

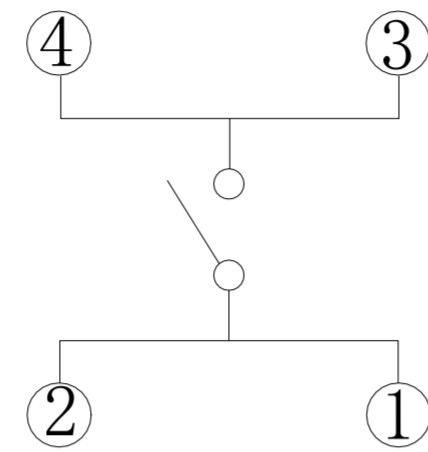
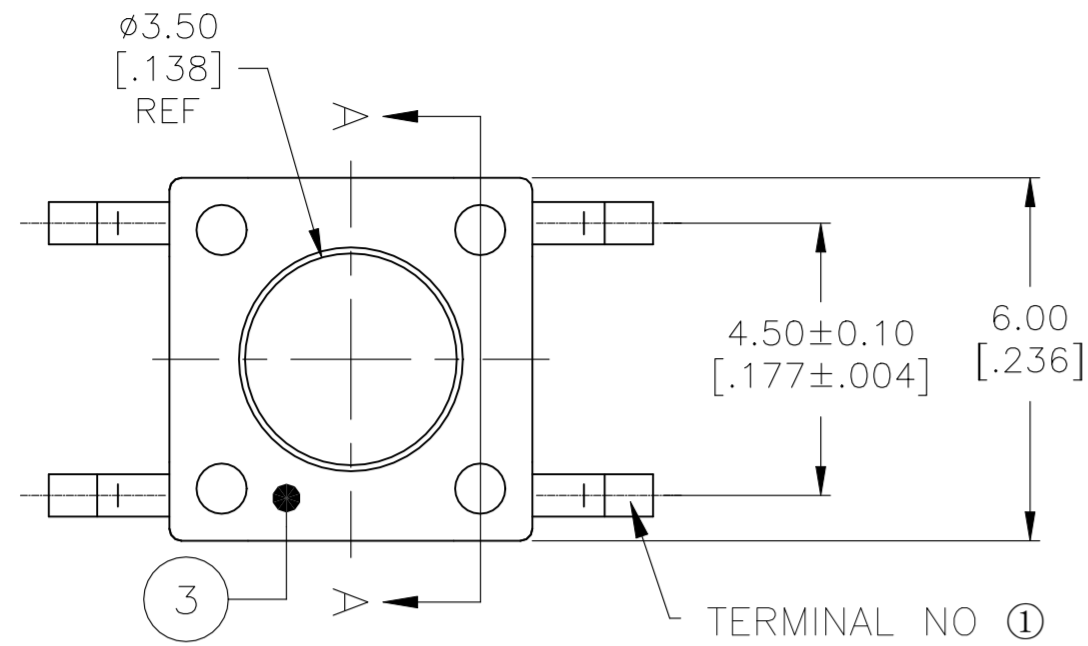

CIRCUIT DIAGRAM

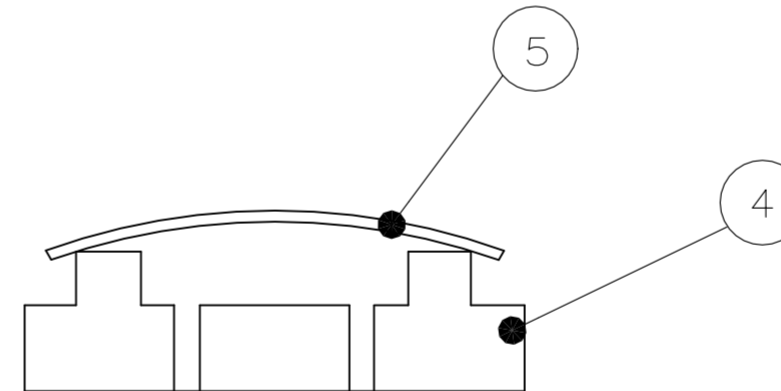
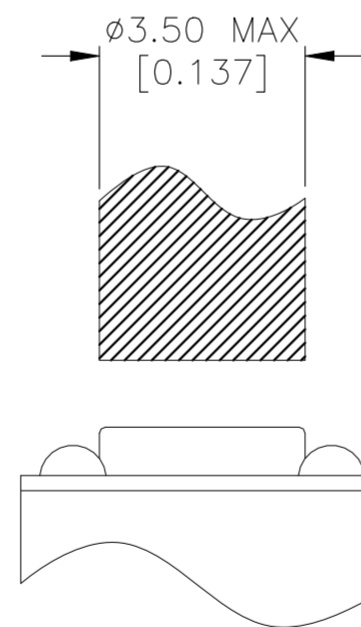
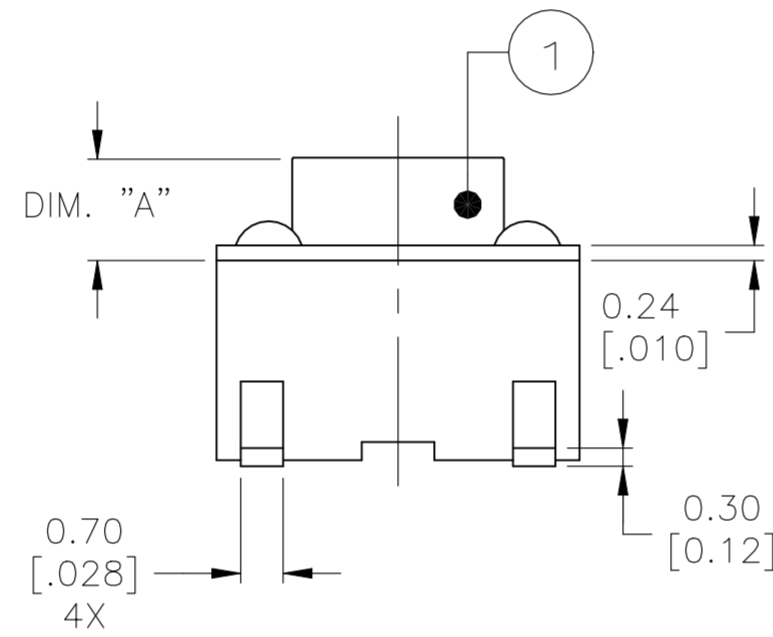
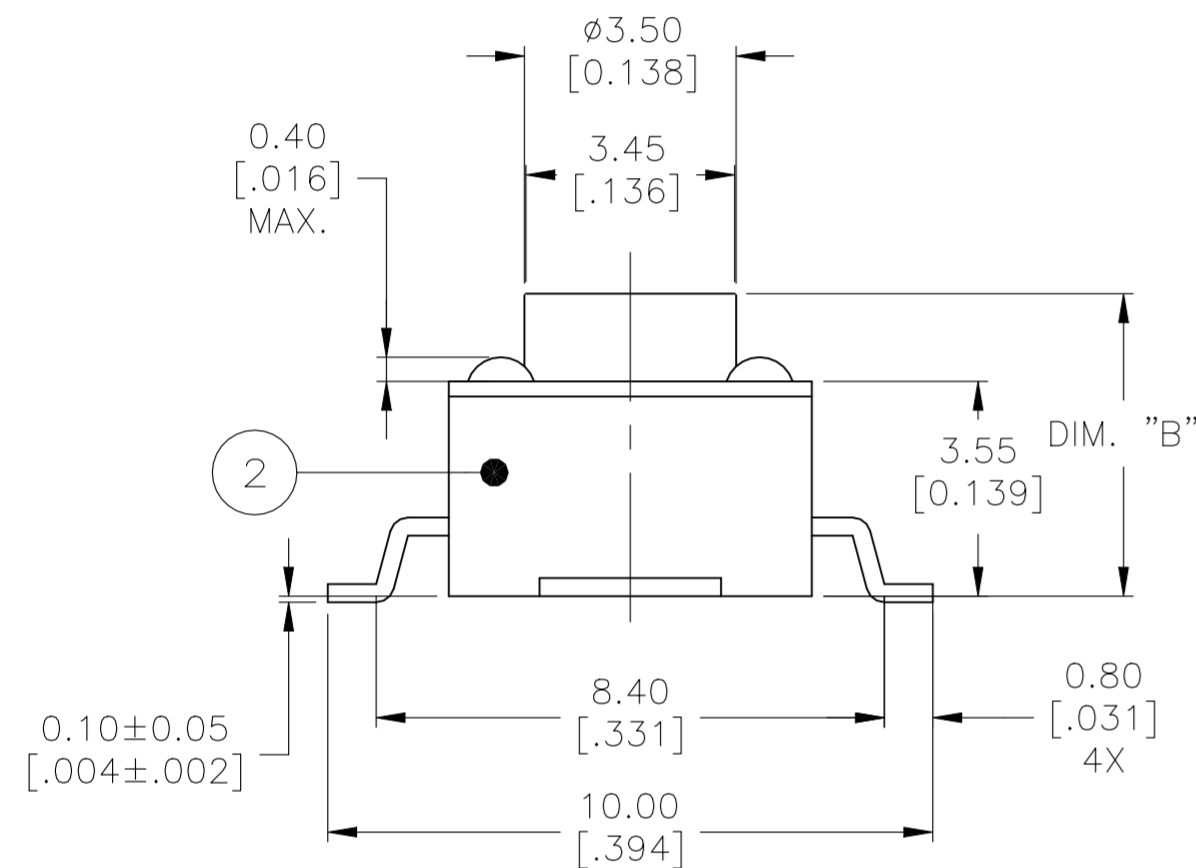

VIEW A-A

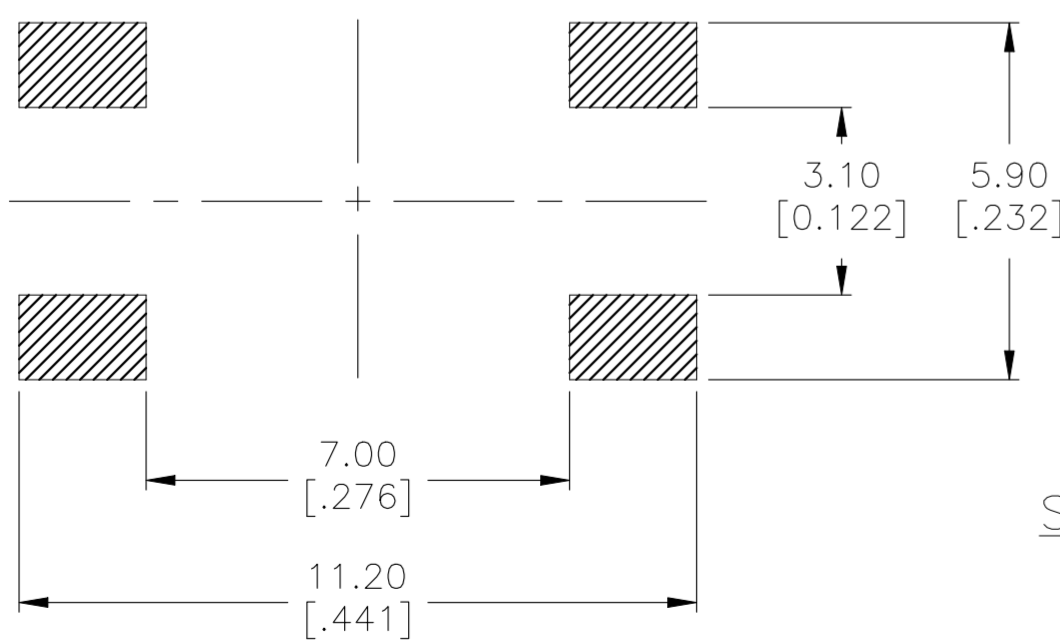

P.C.B LAND DIMENSION

SET MAKER KNOB SIZE (L:4.3mm ONLY)

()-INDICATES MOMENTARY POSITION		
CIRCUIT CHARACTERISTICS		
CONTACT POSITION		CIRCUIT DIAGRAM
OFF	(ON)	
	1 - 3 2 - 4	

THIS DRAWING IS A CONTROLLED DOCUMENT.		DWN M.BINNER 07NOV2007	TE Connectivity Ltd.	
DIMENSIONS: mm [INCHES]		CHK M.SARVER 07NOV07		
TOLERANCES UNLESS OTHERWISE SPECIFIED:		APVD M.SARVER 07NOV07	NAME MICRO MINIATURE PUSHBUTTON SWITCH FSM JSM	
0 PLC ± - 1 PLC ± - 2 PLC ± 0.30[0.012] 3 PLC ± - 4 PLC ± - ANGLES ± 1°		PRODUCT SPEC	SIZE A2	
MATERIAL		APPLICATION SPEC	CAGE CODE 00779	DRAWING NO C=1977223
FINISH		WEIGHT	RESTRICTED TO	
		CUSTOMER DRAWING	SCALE 8:1	SHEET 1 of 3
			REV B3	

REVISIONS

P	LTR	DESCRIPTION	DATE	DWN	APVD
-	-	SEE SHEET 1	-	-	-

Life Cycle	Actuator Color	Actuator Material	Actuation Force	PITCH	TAPE WIDTH	DIM B	DIM A	T&B P/N	P/N
1,000,000	GREEN	Nylon	160±50g			13.00±0.20[.512±.008]	9.40±0.10[.370±.004]	FSM14JSMAS	3-1977223-2
1,000,000	DEEP PINK	Nylon	260±50g			13.00±0.20[.512±.008]	9.40±0.10[.370±.004]	FSM14JSMAS	2-1977223-9
1,000,000	GREEN	Nylon	160±50g			13.00±0.20[.512±.008]	9.40±0.10[.370±.004]	FSM14JSMAS	2-1977223-8
1,000,000	BLUE	Nylon	100±30g			13.00±0.20[.512±.008]	9.40±0.10[.370±.004]	FSM14JSMAS	2-1977223-7
1,000,000	DEEP PINK	Nylon	260±50g	12 MM	24 MM	9.50±0.20[.374±.008]	5.89±0.10[.232±.004]	FSM8JSMAS	2-1977223-6
OBSOLETE	DEEP PINK	Nylon	260±50g			9.50±0.20[.374±.008]	5.89±0.10[.232±.004]	FSM8JSMAS	2-1977223-5
1,000,000	GREEN	Nylon	160±50g	12 MM	24 MM	9.50±0.20[.374±.008]	5.89±0.10[.232±.004]	FSM8JSMAS	2-1977223-4
OBSOLETE	GREEN	Nylon	160±50g			9.50±0.20[.374±.008]	5.89±0.10[.232±.004]	FSM8JSMAS	2-1977223-3
1,000,000	BLUE	Nylon	100±30g	12 MM	24 MM	9.50±0.20[.374±.008]	5.89±0.10[.232±.004]	FSM8JSMAS	2-1977223-2
OBSOLETE	BLUE	Nylon	100±30g			9.50±0.20[.374±.008]	5.89±0.10[.232±.004]	FSM8JSMAS	2-1977223-1
1,000,000	DEEP PINK	Nylon	260±50g	12 MM	24 MM	7.01±0.20[.276±.008]	3.40±0.10[.134±.004]	FSM6JSMAS	2-1977223-0
1,000,000	DEEP PINK	Nylon	260±50g			7.01±0.20[.276±.008]	3.40±0.10[.134±.004]	FSM6JSMAS	1-1977223-9
OBSOLETE	GREEN	Nylon	160±50g	12 MM	24 MM	7.01±0.20[.276±.008]	3.40±0.10[.134±.004]	FSM6JSMAS	1-1977223-8
OBSOLETE	GREEN	Nylon	160±50g			7.01±0.20[.276±.008]	3.40±0.10[.134±.004]	FSM6JSMAS	1-1977223-7
1,000,000	BLUE	Nylon	100±30g	12 MM	24 MM	7.01±0.20[.276±.008]	3.40±0.10[.134±.004]	FSM6JSMAS	1-1977223-6
1,000,000	BLUE	Nylon	100±30g			7.01±0.20[.276±.008]	3.40±0.10[.134±.004]	FSM6JSMAS	1-1977223-5
OBSOLETE	VIOLET	Nylon	70±30g	12 MM	16 MM	4.98±0.25[.196±.010]	1.40±0.10[.055±.004]	FSM4JSMAS	1-1977223-4
OBSOLETE	VIOLET	Nylon	70±30g			4.98±0.25[.196±.010]	1.40±0.10[.055±.004]	FSM4JSMAS	1-1977223-3
OBSOLETE	DEEP PINK	Nylon	260±50g	12 MM	16 MM	4.98±0.25[.196±.010]	1.40±0.10[.055±.004]	FSM4JSMAS	1-1977223-2
OBSOLETE	DEEP PINK	Nylon	260±50g			4.98±0.25[.196±.010]	1.40±0.10[.055±.004]	FSM4JSMAS	1-1977223-1
1,000,000	GREEN	Nylon	160±50g	12 MM	16 MM	4.98±0.25[.196±.010]	1.40±0.10[.055±.004]	FSM4JSMAS	1-1977223-0
1,000,000	GREEN	Nylon	160±50g			4.98±0.25[.196±.010]	1.40±0.10[.055±.004]	FSM4JSMAS	1977223-9
SUPERCEDED BY 1571563-8	BLUE	Nylon	100±30g	12 MM	16 MM	4.98±0.25[.196±.010]	1.40±0.10[.055±.004]	FSM4JSMAS	1977223-8
SUPERCEDED BY 1571563-7	BLUE	Nylon	100±30g			4.98±0.25[.196±.010]	1.40±0.10[.055±.004]	FSM4JSMAS	1977223-7
1,000,000	DEEP PINK	Nylon	260±50g	12 MM	16 MM	4.29±0.20[.169±.008]	0.71±0.10[.028±.004]	FSM2JSMAS	1977223-6
1,000,000	DEEP PINK	Nylon	260±50g			4.29±0.20[.169±.008]	0.71±0.10[.028±.004]	FSM2JSMAS	1977223-5
1,000,000	GREEN	Nylon	160±50g	12 MM	16 MM	4.29±0.20[.169±.008]	0.71±0.10[.028±.004]	FSM2JSMAS	1977223-4
1,000,000	GREEN	Nylon	160±50g			4.29±0.20[.169±.008]	0.71±0.10[.028±.004]	FSM2JSMAS	1977223-3
1,000,000	BLUE	Nylon	100±30g	12 MM	16 MM	4.29±0.20[.169±.008]	0.71±0.10[.028±.004]	FSM2JSMAS	1977223-2
1,000,000	BLUE	Nylon	100±30g			4.29±0.20[.169±.008]	0.71±0.10[.028±.004]	FSM2JSMAS	1977223-1

SUPERCEDED BY 1571563-8
 SUPERCEDED BY 1571563-7

1977223

THIS DRAWING IS A CONTROLLED DOCUMENT.		DWN M.BINNER 07NOV2007	 TE Connectivity Ltd.																			
DIMENSIONS: mm [INCHES]		CHK M.SARVER 07NOV07																				
TOLERANCES UNLESS OTHERWISE SPECIFIED:		APVD M.SARVER 07NOV07	NAME MICRO MINIATURE PUSHBUTTON SWITCH FSM JSM																			
<table border="1"> <tr><td>0 PLC</td><td>±</td><td>-</td></tr> <tr><td>1 PLC</td><td>±</td><td>-</td></tr> <tr><td>2 PLC</td><td>±</td><td>0.30[.012]</td></tr> <tr><td>3 PLC</td><td>±</td><td>-</td></tr> <tr><td>4 PLC</td><td>±</td><td>-</td></tr> <tr><td>ANGLES</td><td>±</td><td>1°</td></tr> </table>		0 PLC	±	-	1 PLC	±	-	2 PLC	±	0.30[.012]	3 PLC	±	-	4 PLC	±	-	ANGLES	±	1°	PRODUCT SPEC -	RESTRICTED TO -	
0 PLC	±	-																				
1 PLC	±	-																				
2 PLC	±	0.30[.012]																				
3 PLC	±	-																				
4 PLC	±	-																				
ANGLES	±	1°																				
MATERIAL -		FINISH -	WEIGHT A2	CAGE CODE 00779																		
		DRAWING NO C=1977223		SCALE 8:1																		
		CUSTOMER DRAWING		SHEET 2 OF 3																		
				REV B3																		

REVISIONS

P	LTR	DESCRIPTION	DATE	DWN	APVD
-	-	SEE SHEET 1	-	-	-

PRODUCT KEY

TYPICAL PRODUCT KEY

FSM 2 JSM L S TR

TYPE

FSM TACTILE SWITCH 6X6mm

ACTUATION LENGTH

2	4.3mm(.169)	8	9.5mm(.374)
4	5.0mm(.196)	14	13.0mm(5.12)
6	7.0mm(.276)		

VERSION

JSM SURFACE MOUNT VERSION

ACTUATION FORCE

XL	0.7±0.3N (70±3gf)	A	1.6±0.5N (160±50gf)
L	1.0±0.3N (100±3gf)	AA	2.6±0.5N (520±50gf)

SWITCHING DOME

S STEEL DOME

PACKAGING

BLANK BULK
TR TAPE & REEL

1977223

B

THIS DRAWING IS A CONTROLLED DOCUMENT.		DWN M.BINNER 07NOV2007	 TE Connectivity Ltd.	
DIMENSIONS: mm [INCHES]		CHK M.SARVER 07NOV07		
TOLERANCES UNLESS OTHERWISE SPECIFIED:		APVD M.SARVER 07NOV07	NAME MICRO MINIATURE PUSHBUTTON SWITCH FSM JSM	
0 PLC ± - 1 PLC ± - 2 PLC ± 0.30[.012] 3 PLC ± - 4 PLC ± - ANGLES ± 1°		PRODUCT SPEC -	RESTRICTED TO -	
MATERIAL -		FINISH -	WEIGHT -	SIZE A2
			CAGE CODE 00779	DRAWING NO C=1977223
CUSTOMER DRAWING			SCALE 8:1	SHEET 3 OF 3
			REV B3	