

NO.	PARTS DESCRIPTION	QTY	MATERIAL	FINISH
①	HOUSING	1	LIQUID CRYSTAL POLYMER (WHITE)	—
②	TERMINAL	8	PHOSPHOR BRONZE	CONTACT AREA:GOLD 0.5um MIN. SOLDER AREA:TIN 1.0um MIN. UNDER PLATING NICKEL 1.0um MIN.
③	SHELL	1	STAINLESS STEEL	—
④	NAIL	4	PHOSPHOR BRONZE	ALL OVER:TIN 1.0um MIN.

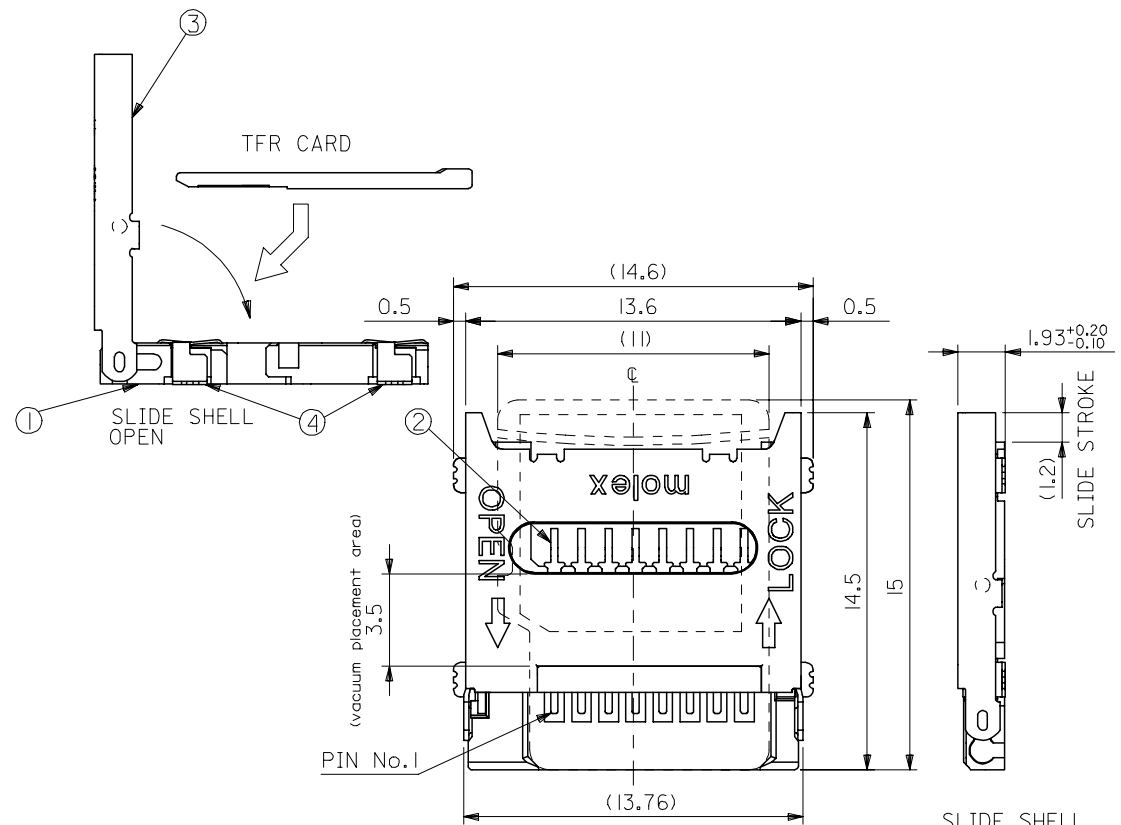

SLIDE SHELL LOCK

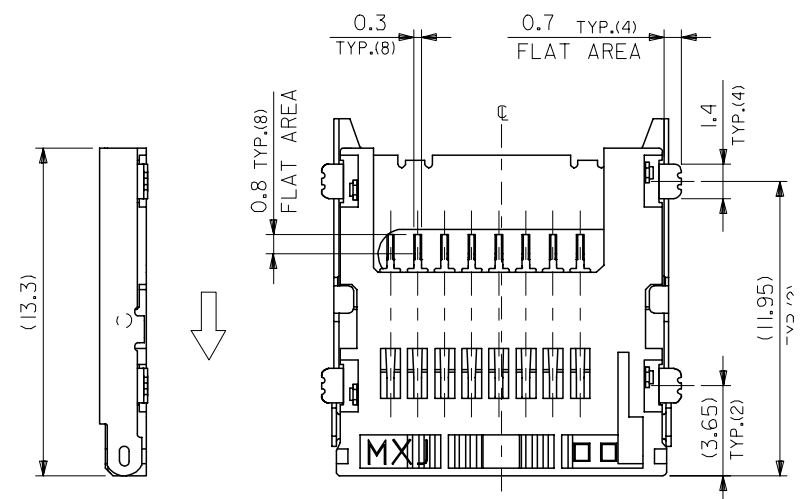

SLIDE SHELL OPEN

NOTE

* EACH TERMINALS AND NAILS COPLANARITY TO BE 0.1 MAX.

WITH EMBOSSED TAPE	500901-0800	500901-08**
CONNECTOR ONLY	500901-0819	
PACKAGE	MATERIAL No.	MODEL No.

REVISED EC No: J2005-2205 DRAWN: KSETO 2005/02/03 CHKD: TWATANABE 2005/02/03 APPR: JMI YAZAWA 2005/02/08	GENERAL TOLERANCES (UNLESS SPECIFIED)		DIMENSION STYLE MM ONLY		SCALE 5:1	DESIGN UNITS METRIC	THIRD ANGLE PROJECTION
	10 UNDER	±0.2	DRAWN BY TWATANABE	DATE 03/9/30	TITLE TFR MEMORY CARD CONN. HINGE TYPE		
	10 OVER 30 UNDER	±0.25	CHECKED BY HTAKASE	DATE 03/9/30			
	30 OVER	±0.3	APPROVED BY YOITO	DATE 03/9/30	MOLEX INCORPORATED		
	ANGULAR	±3 °	MATERIAL No.	DOCUMENT No.			
DRAFT WHERE APPLICABLE MUST REMAIN WITHIN DIMENSIONS		SEE CHART		SD-500901-001	1 OF 2		
THIS DRAWING CONTAINS INFORMATION THAT IS PROPRIETARY TO MOLEX INCORPORATED AND SHOULD NOT BE USED WITHOUT WRITTEN PERMISSION							

10 9 8 7 6 5 4 3 2 1

F

E

D

C

B

A

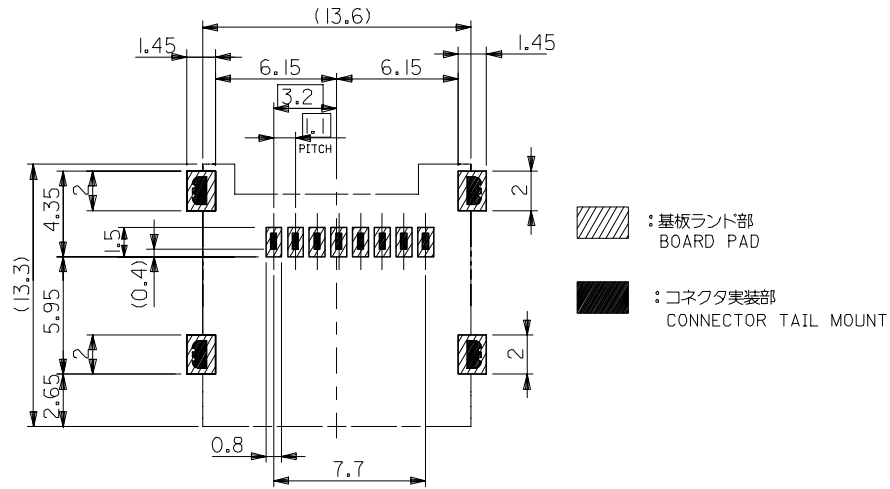

推奨基板寸法(上面図) 一般公差:±0.05
 RECOMMENDED P.C. BOARD LAYOUT(TOP VIEW)
 GENERAL TOLERANCES : ±0.05

REVISED EC NO: J2005-2205 DRAWN: KSETO 2005/02/03 CHK'D: TWATANABE 2005/02/03 APPR: JMI YAZAWA 2005/02/08	GENERAL TOLERANCES (UNLESS SPECIFIED)		DIMENSION STYLE MM ONLY		SCALE 4:1	DESIGN UNITS METRIC	THIRD ANGLE PROJECTION	
	10 UNDER	±0.2	DRAWN BY TWATANABE	DATE 03/9/30	TITLE TFR MEMORY CARD CONN. HINGE TYPE			
	10 OVER 30 UNDER	±0.25	CHECKED BY HTAKASE	DATE 03/9/30				
	30 OVER	±0.3	APPROVED BY YOITO	DATE 03/9/30	MOLEX INCORPORATED			
	ANGULAR	±3 °	MATERIAL NO.	DOCUMENT NO. SD-500901-001				
DRAFT WHERE APPLICABLE MUST REMAIN WITHIN DIMENSIONS		SEE CHART		THIS DRAWING CONTAINS INFORMATION THAT IS PROPRIETARY TO MOLEX INCORPORATED AND SHOULD NOT BE USED WITHOUT WRITTEN PERMISSION				

9

8

7

4

3

2

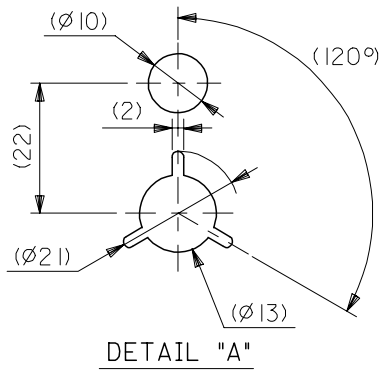
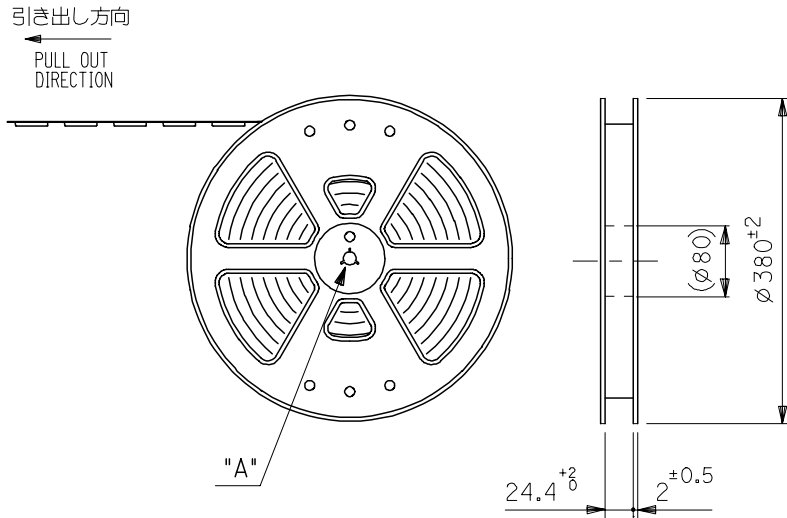

NOTES

- 製品詳細寸法については、SD図面を参照下さい。
THE DETAIL DIMENSIONS REFER TO SALES DRAWING.
- 梱包数量：1400個/リール
NUMBER OF CONNECTORS：1400PCS/REEL
- リードテープ長さ LEAD TAPE LENGTH

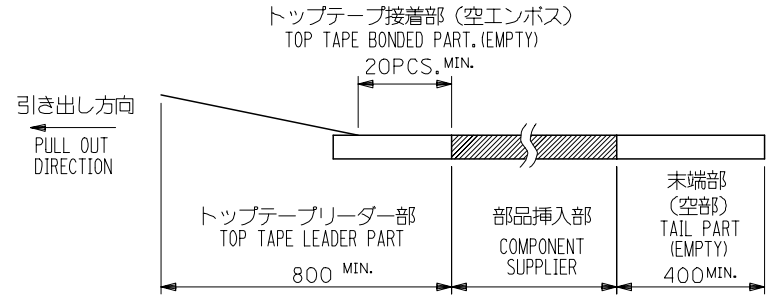

- トップテープの剥離強度：0.1N～1.3N (10.2gf～130gf) (剥離方向は下図参照) 尚、本規格値は出荷時に適用。(但し、輸送時に剥離が発生しないこと。)
PEEL FORCE OF TOP TAPE：0.1N～1.3N (10.2gf～130gf)
(PEEL DIRECTION AS SHOWN IN FOLLOWING FIG.)
THIS REQUIREMENT SHOULD BE APPLIED AT SHIPMENT.
PEEL OFF SHOULD NOT BE ALLOWED, DURING TRANSPORTATION.

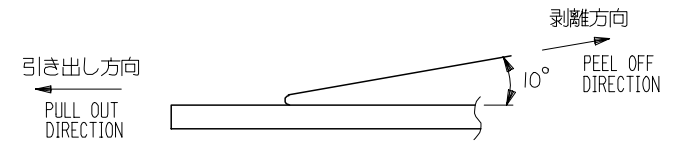

5. 材料 (MATERIAL)

キャリアテープ (CARRIER TAPE)：ポリプロピレン (POLYPROPYLENE)
 トップテープ (TOPTAPE)：PET, PE, PEF
 リール (REEL)：ポリスチレン (PS) <リサイクル材を含む>
 POLYSTYRENE (PS) <RECYCLE MATERIAL CONTAINED>

REVISED EC NO: J2005-0574 DRAWN: AIDA 2004/08/31 CHKD: HTAKASE 2004/08/31 APPR: JIM YAZAW 2004/09/02	GENERAL TOLERANCES (UNLESS SPECIFIED)		DIMENSION STYLE MM ONLY		SCALE ---	DESIGN UNITS METRIC	THIRD ANGLE PROJECTION	
	10 UNDER	±0.2	DRAWN BY MSHINYAMA	DATE 03/09/30	TITLE TFR MEMORY CARD CONN. EMBOSSD TAPE PACKAGE			
	10 OVER 30 UNDER	±0.25	CHECKED BY HTAKASE	DATE 03/09/30	APPROVED BY YOITO			
	30 OVER	±0.3	APPROVED BY YOITO	DATE 03/09/30	MOLEX MOLEX INCORPORATED			
	ANGULAR	±3 °	MATERIAL NO. 500901-0800		DOCUMENT NO. SD-500901-002		SHEET NO. 1 OF 2	
DRAFT WHERE APPLICABLE MUST REMAIN WITHIN DIMENSIONS		SIZE THIS DRAWING CONTAINS INFORMATION THAT IS PROPRIETARY TO MOLEX INCORPORATED AND SHOULD NOT BE USED WITHOUT WRITTEN PERMISSION						

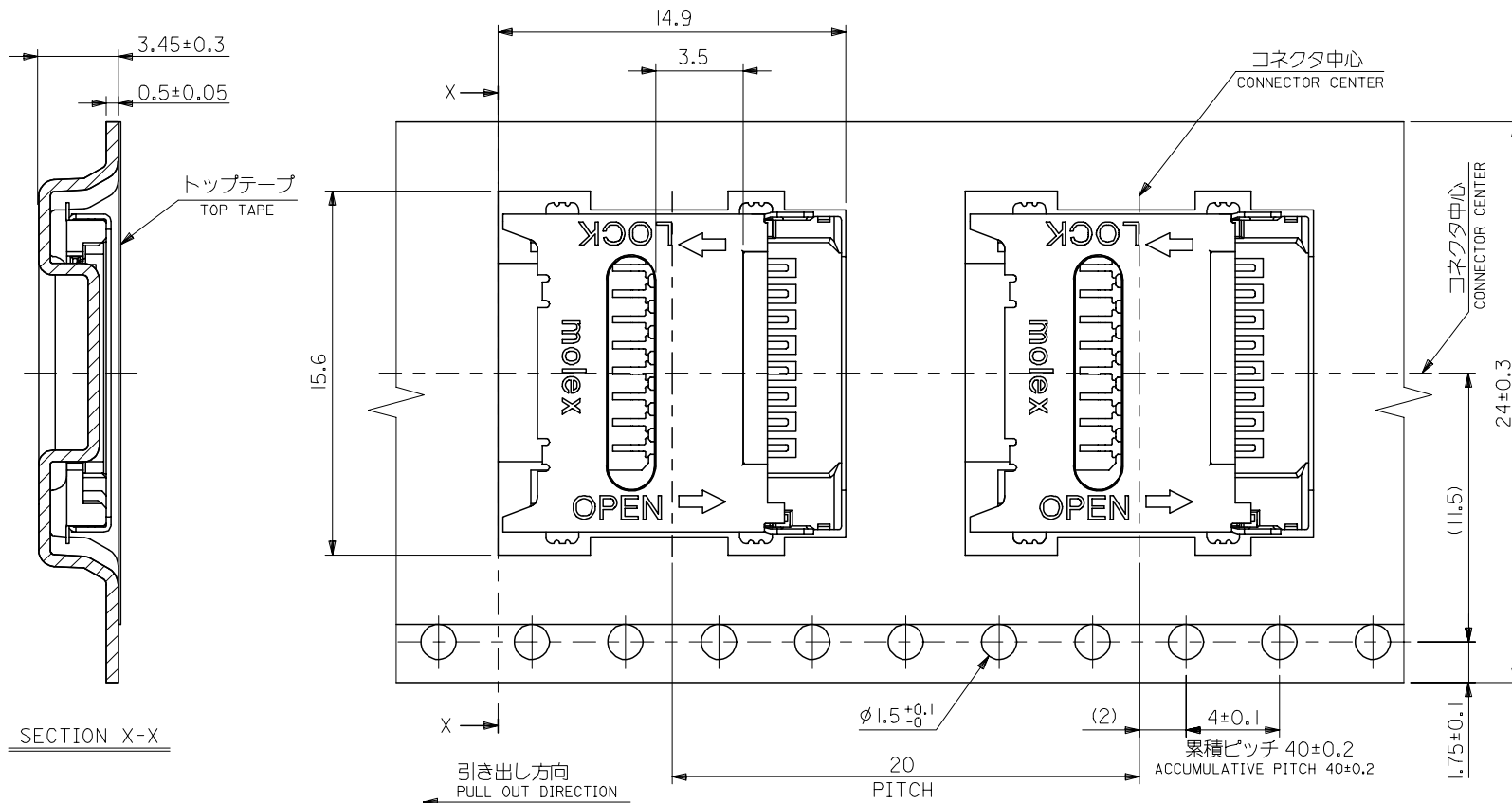

SECTION X-X

REVISED EC NO: J2005-0574 DRAWN: AIDA 2004/08/31 CHKD: HTAKASE 2004/08/31 APPR: JMIYAZAWA 2004/09/02	GENERAL TOLERANCES (UNLESS SPECIFIED)		DIMENSION STYLE MM ONLY		SCALE ---	DESIGN UNITS METRIC	THIRD ANGLE PROJECTION		
	10 UNDER	±0.2	DRAWN BY MSHINYAMA		DATE 03/09/30	TITLE TFR MEMORY CARD CONN. EMBOSSD TAPE PACKAGE			
	10 OVER 30 UNDER	±0.25	CHECKED BY HTAKASE		DATE 03/09/30	MOLEX INCORPORATED			
	30 OVER	±0.3	APPROVED BY YOITO		DATE 03/09/30				
	ANGULAR	±3 °	MATERIAL NO. 500901-0800		DOCUMENT NO. SD-500901-002		SHEET NO. 2 OF 2		
DRAFT WHERE APPLICABLE MUST REMAIN WITHIN DIMENSIONS		SIZE A3		THIS DRAWING CONTAINS INFORMATION THAT IS PROPRIETARY TO MOLEX INCORPORATED AND SHOULD NOT BE USED WITHOUT WRITTEN PERMISSION					