

BGA2776

MMIC wideband amplifier

Rev. 04 — 29 August 2007

Product data sheet

IMPORTANT NOTICE

Dear customer,

As from October 1st, 2006 Philips Semiconductors has a new trade name - NXP Semiconductors, which will be used in future data sheets together with new contact details.

In data sheets where the previous Philips references remain, please use the new links as shown below.

<http://www.philips.semiconductors.com> use <http://www.nxp.com>

<http://www.semiconductors.philips.com> use <http://www.nxp.com> (Internet)

sales.addresses@www.semiconductors.philips.com use salesaddresses@nxp.com (email)

The copyright notice at the bottom of each page (or elsewhere in the document, depending on the version)

- © Koninklijke Philips Electronics N.V. (year). All rights reserved -

is replaced with:

- © NXP B.V. (year). All rights reserved. -

If you have any questions related to the data sheet, please contact our nearest sales office via e-mail or phone (details via salesaddresses@nxp.com). Thank you for your cooperation and understanding,

NXP Semiconductors

MMIC wideband amplifier

BGA2776

FEATURES

- Internally matched
- Very wide frequency range
- Very flat gain
- High gain
- High output power
- Unconditionally stable.

APPLICATIONS

- Cable systems
- LNB IF amplifiers
- General purpose
- ISM.

DESCRIPTION

Silicon Monolithic Microwave Integrated Circuit (MMIC) wideband amplifier with internal matching circuit in a 6-pin SOT363 SMD plastic package.

PINNING

PIN	DESCRIPTION
1	V _S
2, 5	GND2
3	RF out
4	GND1
6	RF in

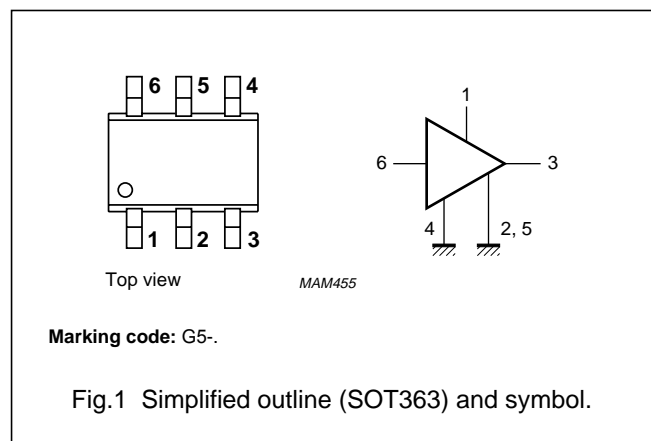

QUICK REFERENCE DATA

SYMBOL	PARAMETER	CONDITIONS	TYP.	MAX.	UNIT
V _S	DC supply voltage		5	6	V
I _S	DC supply current		24.4	–	mA
S ₂₁ ²	insertion power gain	f = 1 GHz	23.2	–	dB
NF	noise figure	f = 1 GHz	4.9	–	dB
P _{L(sat)}	saturated load power	f = 1 GHz	10.5	–	dBm

CAUTION

This product is supplied in anti-static packing to prevent damage caused by electrostatic discharge during transport and handling. For further information, refer to Philips specs.: SNW-EQ-608, SNW-FQ-302A and SNW-FQ-302B.

MMIC wideband amplifier

BGA2776

LIMITING VALUES

In accordance with the Absolute Maximum Rating System (IEC 60134).

SYMBOL	PARAMETER	CONDITIONS	MIN.	MAX.	UNIT
V_S	DC supply voltage	RF input AC coupled	–	6	V
I_S	supply current		–	34	mA
P_{tot}	total power dissipation	$T_s \leq 80\text{ °C}$	–	200	mW
T_{stg}	storage temperature		–65	+150	°C
T_j	operating junction temperature		–	150	°C
P_D	maximum drive power		–	10	dBm

THERMAL CHARACTERISTICS

SYMBOL	PARAMETER	CONDITIONS	VALUE	UNIT
$R_{th\ j-s}$	thermal resistance from junction to solder point	$P_{tot} = 200\text{ mW}; T_s \leq 80\text{ °C}$	300	K/W

CHARACTERISTICS

 $V_S = 5\text{ V}; I_S = 24.4\text{ mA}; f = 1\text{ GHz}; T_j = 25\text{ °C};$ unless otherwise specified.

SYMBOL	PARAMETER	CONDITIONS	MIN.	TYP.	MAX.	UNIT
I_S	supply current		19	24.4	34	mA
$ S_{21} ^2$	insertion power gain	f = 1 GHz	–	23.2	–	dB
		f = 2 GHz	–	23.2	–	dB
$R_{L\ IN}$	return losses input	f = 1 GHz	–	9	–	dB
		f = 2 GHz	–	7	–	dB
$R_{L\ OUT}$	return losses output	f = 1 GHz	–	17	–	dB
		f = 2 GHz	–	9	–	dB
NF	noise figure	f = 1 GHz	–	4.9	–	dB
		f = 2 GHz	–	5.3	–	dB
BW	bandwidth	at $ S_{21} ^2$ –3 dB below flat gain at 1 GHz	–	2.8	–	GHz
$P_{L(sat)}$	saturated load power	f = 1 GHz	–	10.5	–	dBm
		f = 2 GHz	–	8.1	–	dBm
$P_{L\ 1\ dB}$	load power	at 1 dB gain compression; f = 1 GHz	–	7.2	–	dBm
		at 1 dB gain compression; f = 2 GHz	–	6	–	dBm
IP3(in)	input intercept point	f = 1 GHz	–	–4.6	–	dBm
		f = 2 GHz	–	–8.8	–	dBm
IP3(out)	output intercept point	f = 1 GHz	–	18.6	–	dBm
		f = 2 GHz	–	14.4	–	dBm

MMIC wideband amplifier

BGA2776

APPLICATION INFORMATION

Figure 2 shows a typical application circuit for the BGA2776 MMIC. The device is internally matched to 50 Ω, and therefore does not need any external matching. The value of the input and output DC blocking capacitors C2 and C3 should be not more than 100 pF for applications above 100 MHz. However, when the device is operated below 100 MHz, the capacitor value should be increased.

The nominal value of the RF choke L1 is 100 nH. At frequencies below 100 MHz this value should be increased to 220 nH. At frequencies above 1 GHz a much lower value must be used (e.g. 10 nH) to improve return losses. For optimal results, a good quality chip inductor such as the TDK MLG 1608 (0603), or a wire-wound SMD type should be chosen.

Both the RF choke L1 and the 22 nF supply decoupling capacitor C1 should be located as closely as possible to the MMIC.

Separate paths must be used for the ground planes of the ground pins GND1 and GND2, and these paths must be as short as possible. When using vias, use multiple vias per pin in order to limit ground path inductance.

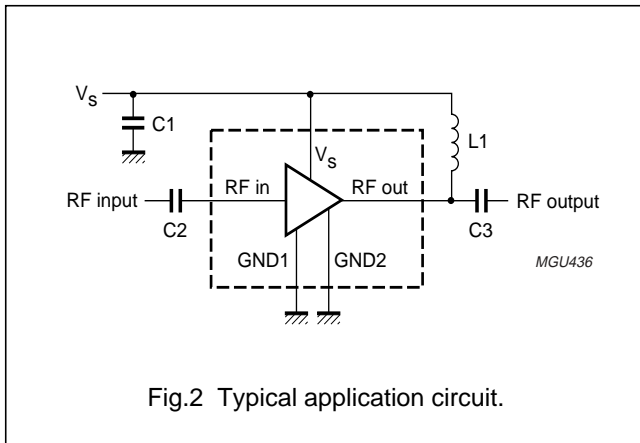

Fig.2 Typical application circuit.

Figure 3 shows two cascaded MMICs. This configuration doubles overall gain while preserving broadband characteristics. Supply decoupling and grounding conditions for each MMIC are the same as those for the circuit of Fig.2.

The excellent wideband characteristics of the MMIC make it an ideal building block in IF amplifier applications such as LBNs (see Fig.4).

As a buffer amplifier between an LNA and a mixer in a receiver circuit, the MMIC offers an easy matching, low noise solution (see Fig.5).

In Fig.6 the MMIC is used as a driver to the power amplifier as part of a transmitter circuit. Good linear performance and matched input and output offer quick design solutions in such applications.

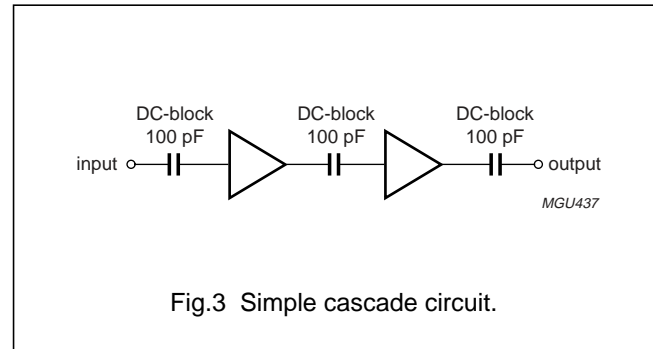

Fig.3 Simple cascade circuit.

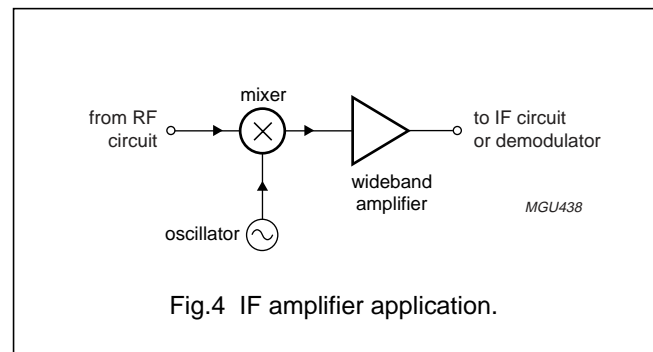

Fig.4 IF amplifier application.

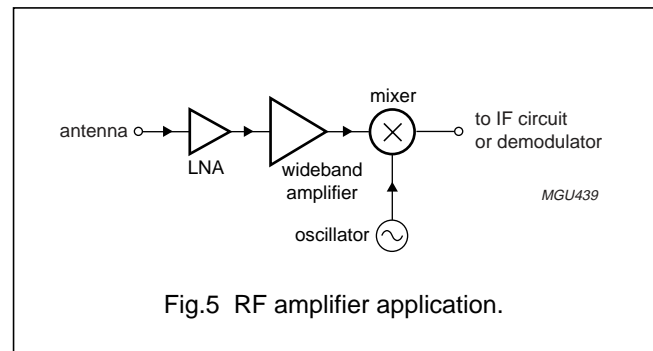

Fig.5 RF amplifier application.

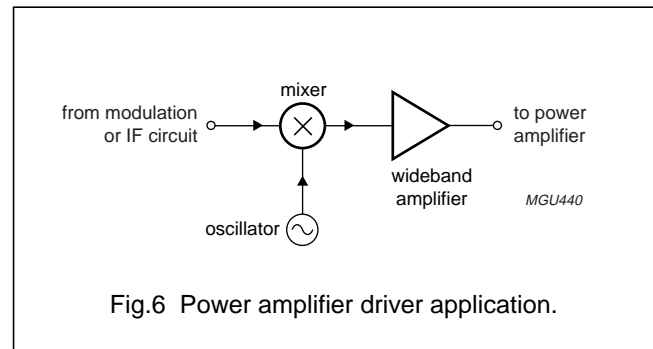
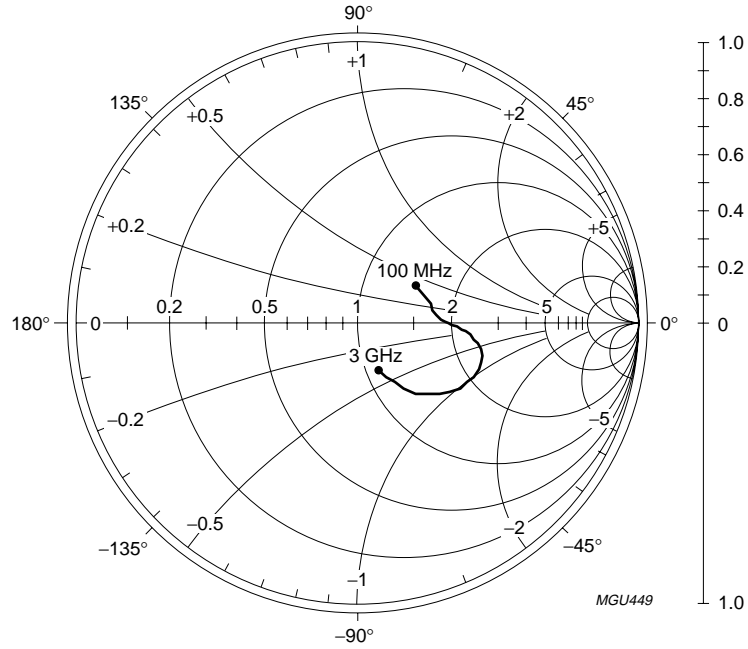

Fig.6 Power amplifier driver application.

MMIC wideband amplifier

BGA2776



$I_S = 23.8 \text{ mA}$; $V_S = 5 \text{ V}$; $P_D = -30 \text{ dBm}$; $Z_O = 50 \Omega$.

Fig.7 Input reflection coefficient (s_{11}); typical values.

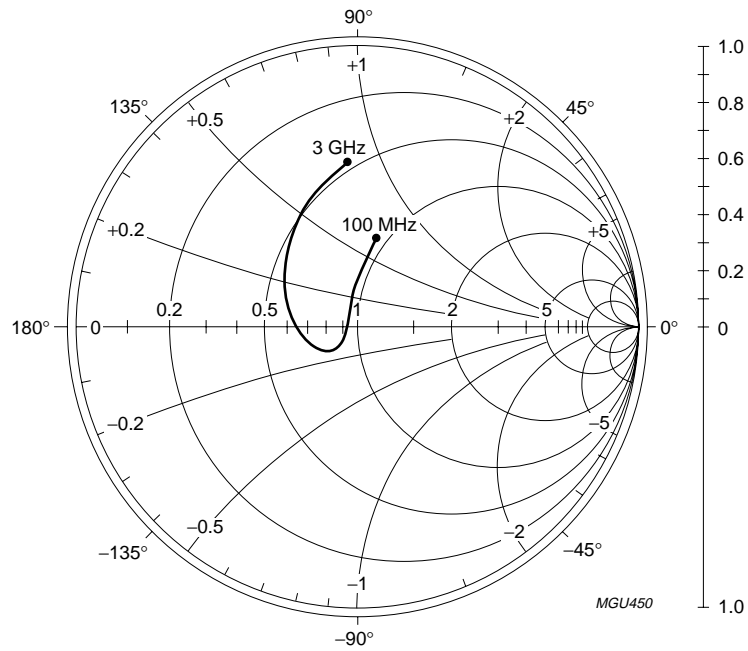

$I_S = 23.8 \text{ mA}$; $V_S = 5 \text{ V}$; $P_D = -30 \text{ dBm}$; $Z_O = 50 \Omega$.

Fig.8 Output reflection coefficient (s_{22}); typical values.

MMIC wideband amplifier

BGA2776

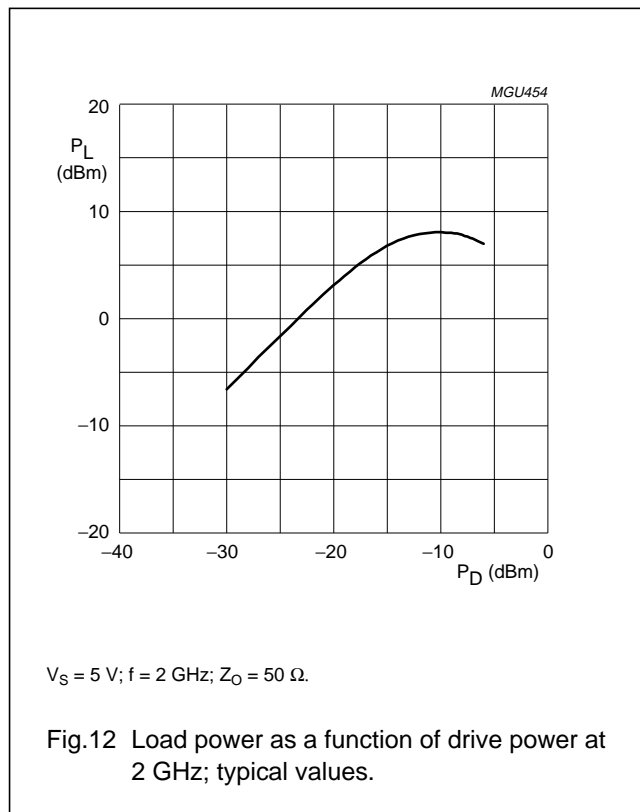
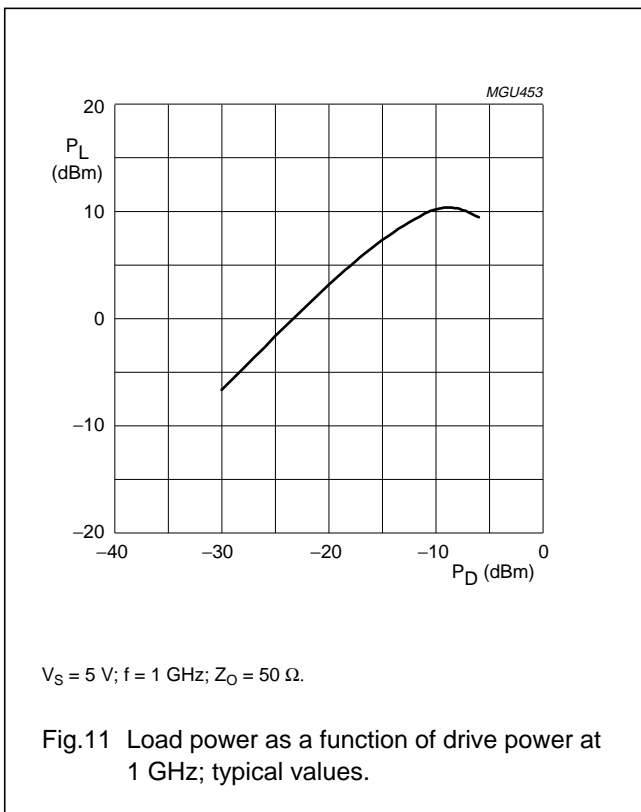
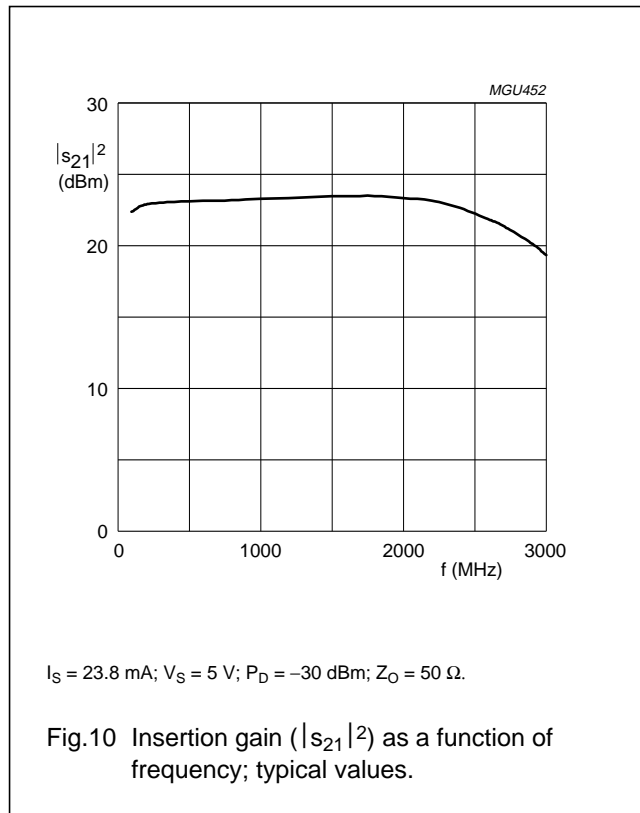
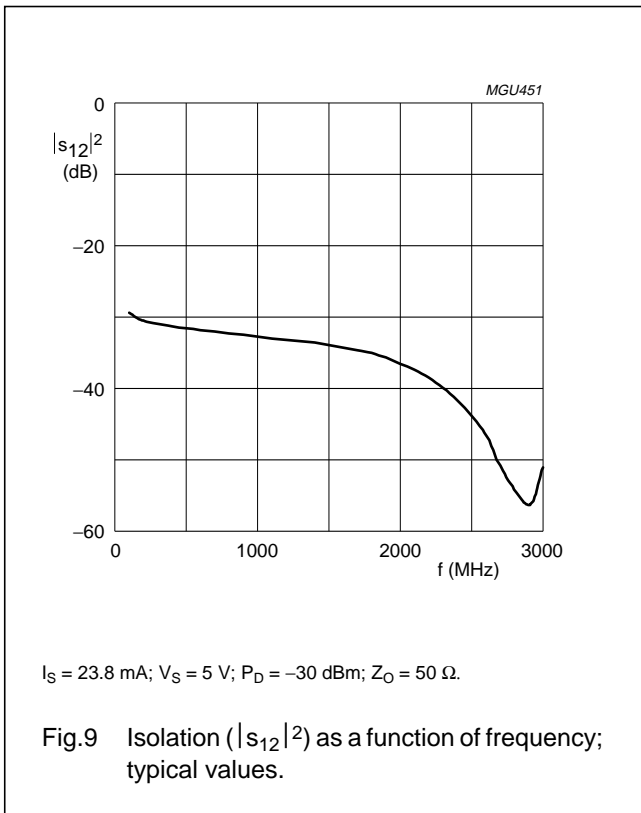

MMIC wideband amplifier

BGA2776

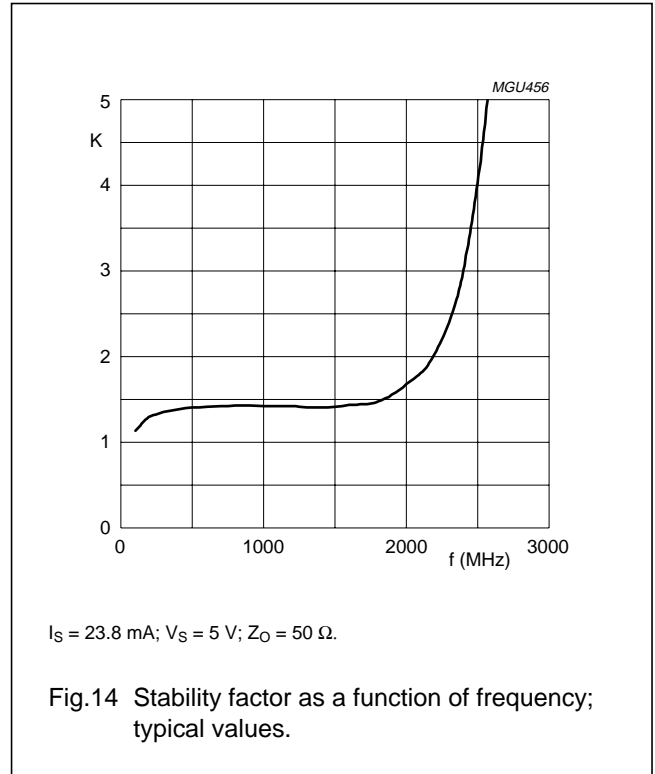
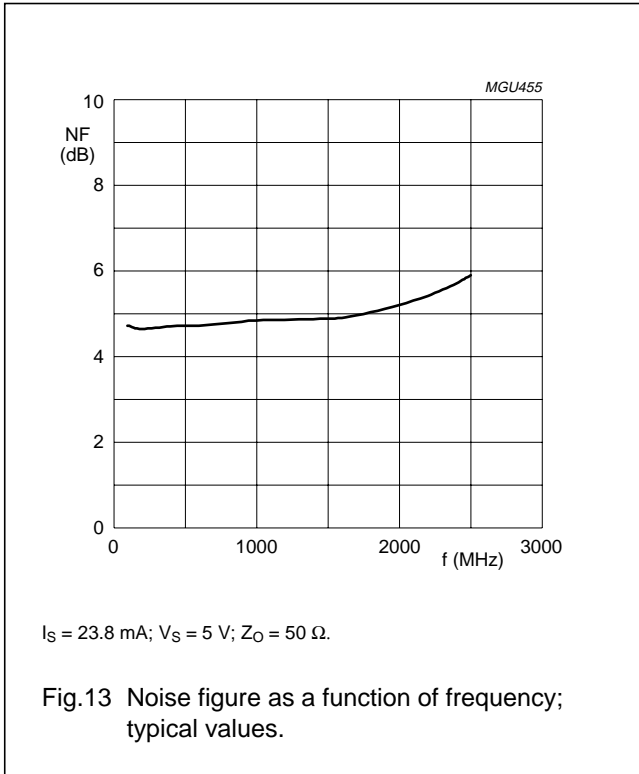

Scattering parameters

$I_S = 23.8 \text{ mA}; V_S = 5 \text{ V}; P_D = -30 \text{ dBm}; Z_O = 50 \Omega; T_{amb} = 25 \text{ }^\circ\text{C}.$

f (MHz)	S ₁₁		S ₂₁		S ₁₂		S ₂₂	
	MAGNITUDE (ratio)	ANGLE (deg)	MAGNITUDE (ratio)	ANGLE (deg)	MAGNITUDE (ratio)	ANGLE (deg)	MAGNITUDE (ratio)	ANGLE (deg)
100	0.24807	33.20	13.128	18.88	0.03393	18.97	0.33203	77.92
200	0.27028	15.23	13.939	1.305	0.02979	7.840	0.16144	92.47
400	0.28518	5.613	14.233	-16.20	0.02720	-3.208	0.04702	127.5
600	0.30074	1.998	14.370	-29.60	0.02573	-8.356	0.05168	-147.7
800	0.32672	0.099	14.418	-42.25	0.02434	-11.95	0.09810	-134.1
1000	0.35611	-1.702	14.566	-54.66	0.02310	-14.59	0.13562	-139.8
1200	0.38865	-4.465	14.683	-67.44	0.02189	-17.14	0.16792	-152.8
1400	0.41966	-7.778	14.828	-80.86	0.02100	-20.38	0.19808	-169.9
1600	0.44966	-12.12	14.911	-94.49	0.01929	-24.40	0.23691	171.6
1800	0.46509	-17.78	14.941	-109.4	0.01774	-29.44	0.28834	153.5
2000	0.45980	-24.85	14.688	-124.9	0.01494	-36.30	0.34770	137.6
2200	0.43684	-32.59	14.389	-140.7	0.01193	-41.31	0.40964	124.2
2400	0.38779	-40.66	13.533	-157.9	0.00828	-43.81	0.46607	113.1
2600	0.32424	-50.49	12.355	-174.5	0.00477	-48.94	0.51421	105.9
2800	0.25311	-57.33	11.049	169.3	0.00146	-17.41	0.56131	98.30
3000	0.18665	-65.52	9.2745	154.9	0.00279	94.00	0.59748	93.63

MMIC wideband amplifier

BGA2776

PACKAGE OUTLINE

Plastic surface mounted package; 6 leads

SOT363

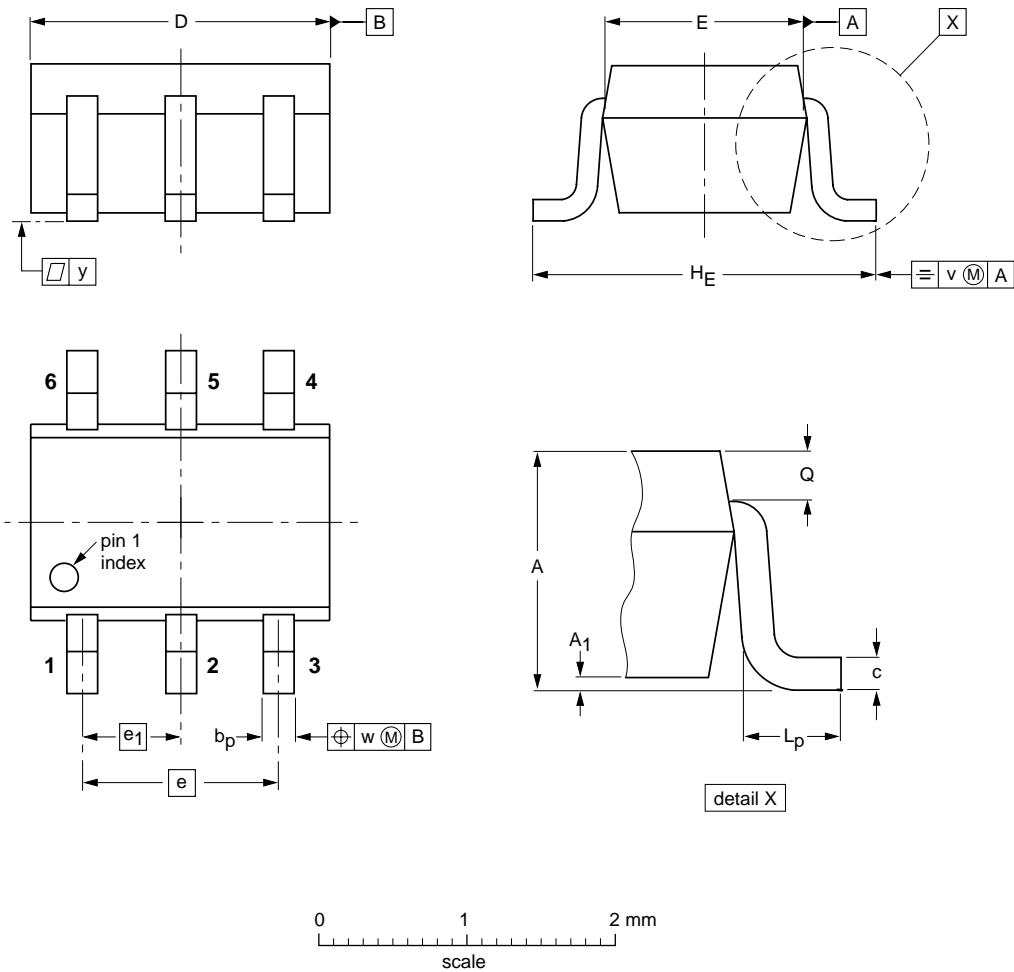

DIMENSIONS (mm are the original dimensions)

UNIT	A	A1 max	bp	c	D	E	e	e1	HE	Lp	Q	v	w	y
mm	1.1 0.8	0.1	0.30 0.20	0.25 0.10	2.2 1.8	1.35 1.15	1.3	0.65	2.2 2.0	0.45 0.15	0.25 0.15	0.2	0.2	0.1

OUTLINE VERSION	REFERENCES				EUROPEAN PROJECTION	ISSUE DATE
	IEC	JEDEC	EIAJ			
SOT363			SC-88			97-02-28

Legal information

Data sheet status

Document status ^{[1][2]}	Product status ^[3]	Definition
Objective [short] data sheet	Development	This document contains data from the objective specification for product development.
Preliminary [short] data sheet	Qualification	This document contains data from the preliminary specification.
Product [short] data sheet	Production	This document contains the product specification.

[1] Please consult the most recently issued document before initiating or completing a design.

[2] The term 'short data sheet' is explained in section "Definitions".

[3] The product status of device(s) described in this document may have changed since this document was published and may differ in case of multiple devices. The latest product status information is available on the Internet at URL <http://www.nxp.com>.

Definitions

Draft — The document is a draft version only. The content is still under internal review and subject to formal approval, which may result in modifications or additions. NXP Semiconductors does not give any representations or warranties as to the accuracy or completeness of information included herein and shall have no liability for the consequences of use of such information.

Short data sheet — A short data sheet is an extract from a full data sheet with the same product type number(s) and title. A short data sheet is intended for quick reference only and should not be relied upon to contain detailed and full information. For detailed and full information see the relevant full data sheet, which is available on request via the local NXP Semiconductors sales office. In case of any inconsistency or conflict with the short data sheet, the full data sheet shall prevail.

Disclaimers

General — Information in this document is believed to be accurate and reliable. However, NXP Semiconductors does not give any representations or warranties, expressed or implied, as to the accuracy or completeness of such information and shall have no liability for the consequences of use of such information.

Right to make changes — NXP Semiconductors reserves the right to make changes to information published in this document, including without limitation specifications and product descriptions, at any time and without notice. This document supersedes and replaces all information supplied prior to the publication hereof.

Suitability for use — NXP Semiconductors products are not designed, authorized or warranted to be suitable for use in medical, military, aircraft, space or life support equipment, nor in applications where failure or

malfunction of a NXP Semiconductors product can reasonably be expected to result in personal injury, death or severe property or environmental damage. NXP Semiconductors accepts no liability for inclusion and/or use of NXP Semiconductors products in such equipment or applications and therefore such inclusion and/or use is at the customer's own risk.

Applications — Applications that are described herein for any of these products are for illustrative purposes only. NXP Semiconductors makes no representation or warranty that such applications will be suitable for the specified use without further testing or modification.

Limiting values — Stress above one or more limiting values (as defined in the Absolute Maximum Ratings System of IEC 60134) may cause permanent damage to the device. Limiting values are stress ratings only and operation of the device at these or any other conditions above those given in the Characteristics sections of this document is not implied. Exposure to limiting values for extended periods may affect device reliability.

Terms and conditions of sale — NXP Semiconductors products are sold subject to the general terms and conditions of commercial sale, as published at <http://www.nxp.com/profile/terms>, including those pertaining to warranty, intellectual property rights infringement and limitation of liability, unless explicitly otherwise agreed to in writing by NXP Semiconductors. In case of any inconsistency or conflict between information in this document and such terms and conditions, the latter will prevail.

No offer to sell or license — Nothing in this document may be interpreted or construed as an offer to sell products that is open for acceptance or the grant, conveyance or implication of any license under any copyrights, patents or other industrial or intellectual property rights.

Trademarks

Notice: All referenced brands, product names, service names and trademarks are the property of their respective owners.

Contact information

For additional information, please visit: <http://www.nxp.com>

For sales office addresses, send an email to: salesaddresses@nxp.com

Revision history

Revision history

Document ID	Release date	Data sheet status	Change notice	Supersedes
BGA2776_N_4	20070829	Product data sheet	-	BGA2776_3
Modifications:	<ul style="list-style-type: none"> amended marking code (Fig. 1) 			
BGA2776_3 (9397 750 10016)	20020806	Product specification	-	BGA2776_2
BGA2776_2 (9397 750 08548)	20011019	Product specification	-	BGA2776_N_1
BGA2776_N_1 (9397 750 08193)	20010330	Preliminary specification	-	-

Please be aware that important notices concerning this document and the product(s) described herein, have been included in section 'Legal information'.



© NXP B.V. 2007.

All rights reserved.

For more information, please visit: <http://www.nxp.com>

For sales office addresses, please send an email to: salesaddresses@nxp.com

Date of release: 29 August 2007

Document identifier: BGA2776_N_4