



HYT 271/939/939p/221

Digital Humidity and Temperature Module

Optimal for general purpose humidity applications with best accuracy at 0 - 50 °C and 0 - 90 % RH

Benefits & Characteristics

- Fast response time (HYT 271)
- Low hysteresis
- Low drift
- Stable at high humidity
- Custom specific versions
- Humidity and temperature sensor with excellent accuracy
- Easy integration, interchangeable without adjustments
- I²C protocol
- Fully calibrated and temperature compensated

The HYT humidity module family

HYT 271

The fastest and smallest of the HYT family is the 271. The digital module with only 10.2 x 5.1 x 1.8 mm size offers a wide application window and an optimal price-performance-ratio. It is only the best solution for fast measurements or sophisticated mass applications.



HYT 221

The round stainless-steel casing can be easily fitted into housing openings and sealed against a wall with the use of an O-Ring. The hydrophobic/oleophobic PTFE membrane filter protects the sensor from dust and liquids while providing a high dynamic responsiveness.



HYT 939/939p

The strongest of the HYT modules in TO39 packaging particularly features mechanical robustness. Through glass to metal seals and welding of the stainless-steel cap onto the metal header, it is pressure tight up to 16 bar in the 939p version.



Custom specific versions:

If a higher accuracy or different sensor design is needed, the modular design of HYT allows for high flexibility – the sensor, its calibration and assembly can easily be adapted to develop tailor-made modules fulfilling individual demands. Customized IST AG humidity modules feature extraordinary response times, high accuracies in condensing environment or low humidity conditions. Please contact us for custom specific versions.



HYT 271

Mechanical Dimensions

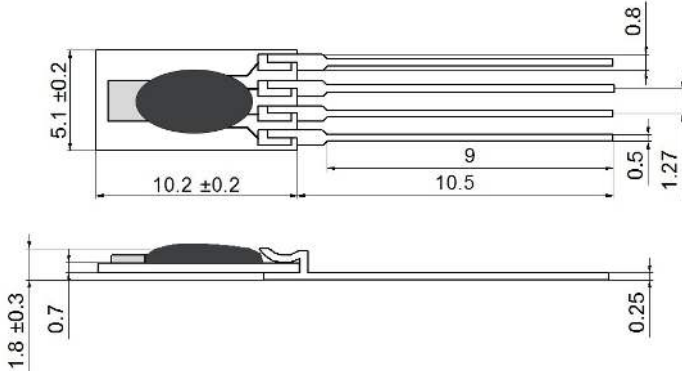

Pin Assignment

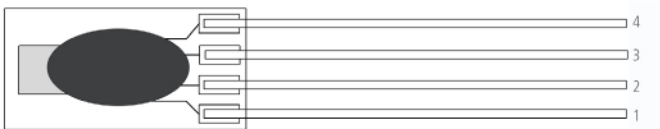

1	2	3	4
SDA	GND	VDD	SCL

HYT 221

Mechanical Dimensions

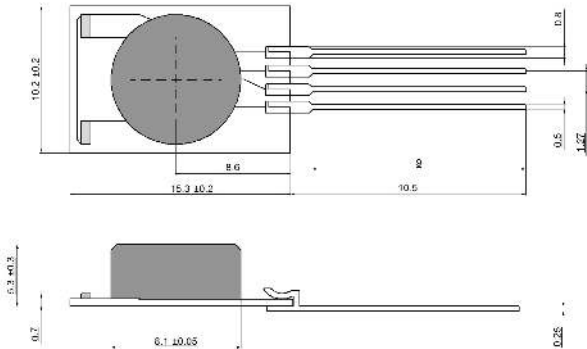

Pin Assignment

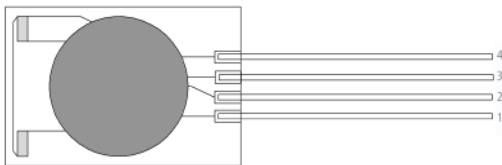

1	2	3	4
SDA	GND	VCC	SCL



HYT 939/939p

Mechanical Dimensions

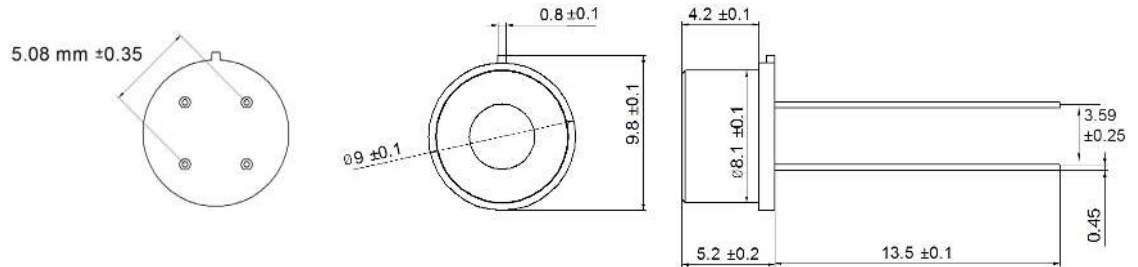

Pin Assignment

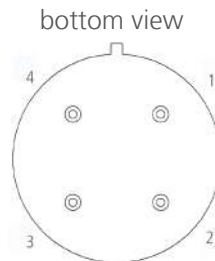

1	2	3	4
SCL	VCC	GND	SDA

HYT 939p

Pressure tight < 16 bar

Order information

Version	HYT 271	HYT 221	HYT 939	HYT 939p
Order code	153349	103923	153656	153658
Former order code	150.00066	150.00068	150.00067	150.00096

Additional Documents

	Document name
Application Note	AHHYTM_E

Please find software code examples on www.ist-ag.com.



Innovative Sensor Technology IST AG, Stegrütistrasse 14, 9642 Ebnat-Kappel, Switzerland
Phone: +41 71 992 01 00 | Fax: +41 71 992 01 99 | Email: info@ist-ag.com | www.ist-ag.com