

**STRAIGHT PLUG SOLDER TYPE  
CABLE .141**

**R124.054.003**  
**SERIES SMA-COM**

Hex .315/flats  
(hex. 8/Plats)

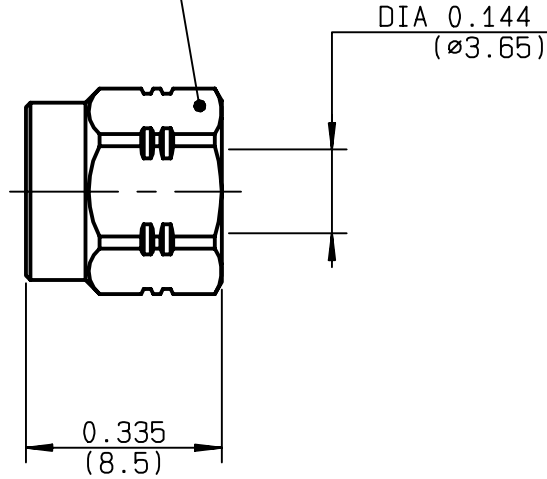

NOMINAL IMPEDANCE	<b>50</b> Ω	CABLES : <b>KS 2</b> <b>RG 402</b>
FREQUENCY RANGE	<b>0-18</b> GHz	
TEMPERATURE RATING	<b>-65/+105</b> °C	
V.S.W.R	<b>1.05</b> + <b>.01</b> x F(GHz)Maxi	
RF INSERTION LOSS	<b>0.05</b> √F(GHz) dB Maxi	
VOLTAGE RATING	<b>500</b> Veff Maxi	
DIELECTRIC WITHSTANDING VOLTAGE	<b>1000</b> Veff Mini	
INSULATION RESISTANCE	<b>5000</b> MΩMini	
HERMETIC SEAL	<b>NA</b> Atm.cm <sup>3</sup> /s	
LEAKAGE (pressurized only)	<b>NA</b>	
MECHANICAL DURABILITY	<b>100</b> Cycles	OTHERS CHARACTERISTICS
WEIGHT	<b>2.1</b> gr	CABLE RETENTION <b>270</b> N Mini
SPECIFICATION		CENTER CONTACT RETENTION
		Axial force - mating end <b>NA</b> N Mini
		Axial force - opposite end <b>NA</b> N Mini
		Torque <b>NA</b> cm.N Mini
		RECOMMENDED TORQUES
		Mating <b>60</b> cm.N
		Panel nut <b>NA</b> cm.N
		Clamp nut <b>NA</b> cm.N

CONNECTOR PARTS	MATERIALS	FINISH (all values are given in micrometers)
BODY	BRASS	GOLD 0.2 OVER NICKEL 2
OUTER CONTACT		
CENTER CONTACT		
INSULATOR		-
GASKET	SILICONE RUBBER	-
OTHERS PIECES	BRASS	GOLD 0.2 OVER NICKEL 2

ISSUE	CREATION DATE	FILE PART-NUMBER
<b>9847A01</b>	<b>17/07/1996</b>	<b>96-1200-066</b>



**RADIALL**®

TRIQUES

The information given here is subject to change without notice.  
Design changes may be in order to improve the product .

*Connect to the future*



**R124.054.003**

ISSUE 9847A01 SERIES SMA-COM

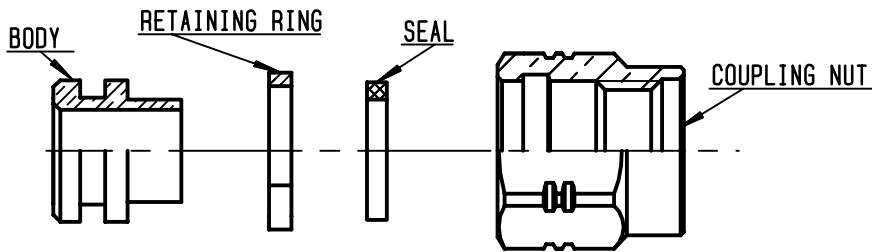

we recommend a cable thermal preconditioning before assembling

①

- Place the cable into the assembly jig (R282.740.000)
- Place the connector body and positioner (R282.744.100) onto the cable and clamp cable.
- Put 3 rings of solder around the cable.
- Solder the body onto the cable.
- 
- 

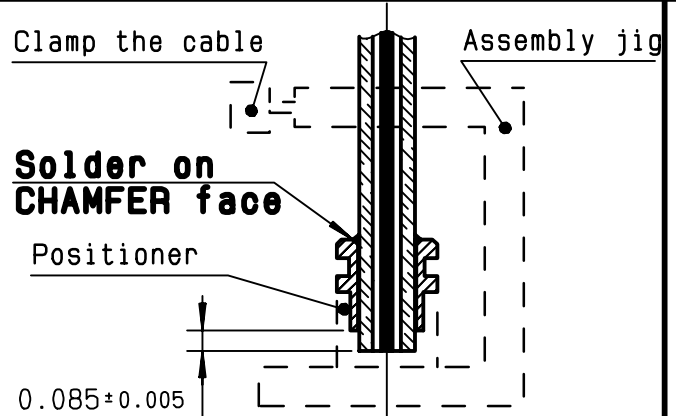

②

- Immobilize the cable using the thumb crew on the cable holder (R282.059.100).
- Get the positioner into the connector groove, using knurled push-button.
- Push button until it stops.
- Tighten cable.
- Present the stripping tool (R282.053.100) opposite the cable holder.
- Push and turn both elements with respect to each other.
- When the tool stop cutting : pull off without turning it.
- Present the trimmer (R282.066.100) opposite the cable holder, push and turn both elements with respect to each other until fully home.
- Place retaining ring onto its insert tool (R282.760.000).
- Push sub-assembly into the tool until the retaining ring snaps into place.
- Place the interface seal O ring onto body.
- Compress retaining ring using retaining ring pliers. Push coupling nut onto sub-assembly and over retaining ring.

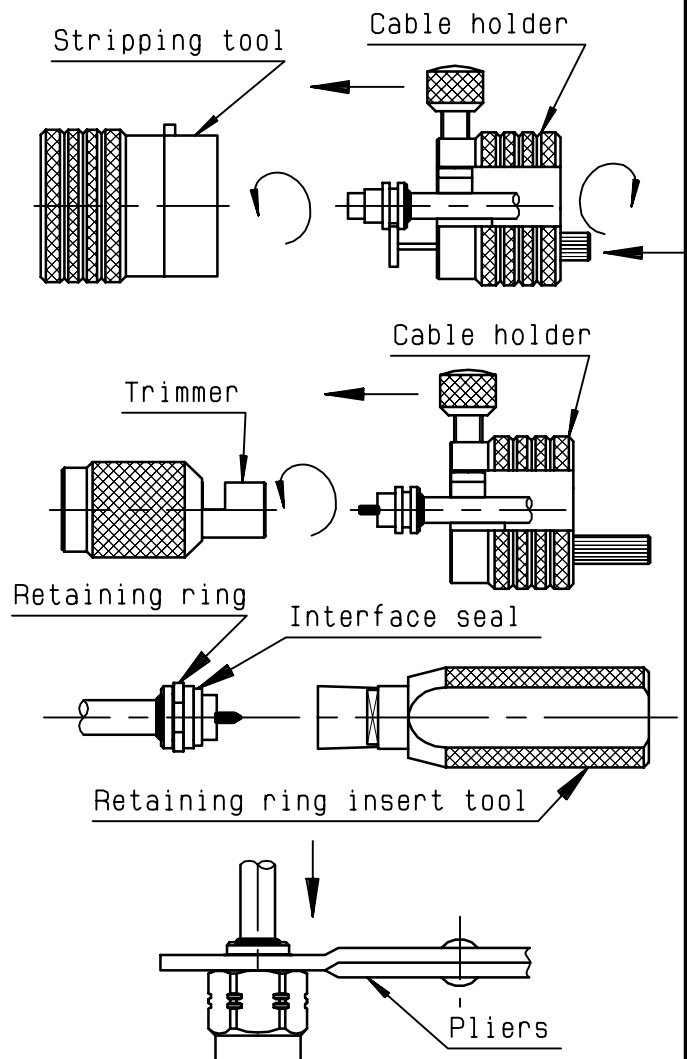

TRIQUES