

APPROVED: _____
 DATE: _____ TITLE: _____

Rev	AWO #	Description	Date	Appr
-		RELEASED	3/30/16	
A		UPDATED SPEC.	6/20/16	HR/CK

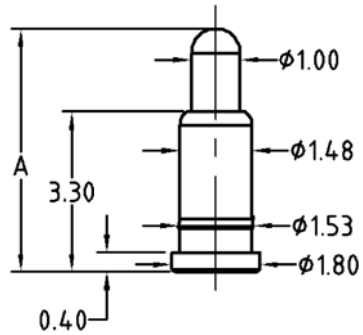

ADAM P/N	Initial Height
PH-MVF-3345	4.5mm
PH-MVF-3350	5.0mm

Working Stroke	Spring Force
1.0mm	70g

Rated Current	Rated Voltage
1A Max	12V

ADAM P/N	Initial Height
PH-MVF-4355	5.5mm
PH-MVF-4360	6.0mm

Working Stroke	Spring Force
1.0mm	70g

Rated Current	Rated Voltage
3A Max	12V

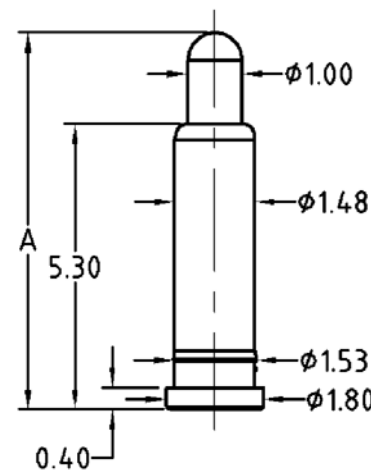

ADAM P/N	Initial Height
PH-MVF-5365	6.5mm
PH-MVF-5370	7.0mm
PH-MVF-5375	7.5mm
PH-MVF-5380	8.0mm

Working Stroke	Spring Force
1.0mm	70g

Rated Current	Rated Voltage
3A Max	12V

SPECIFICATIONS:

Material:
 Plunger: Brass, Gold plated
 Barrel: Brass, Gold plated
 Spring: SUS Surface treatment
 Electrical:
 Contact resistance: 20 mohms max
 Mechanical:
 Full Stroke: 1.40mm
 Durability: 1,000,000 Cycles
 Temperature Rating:
 Operating temperature: -55°C to +125°C
 Environmental:
 Lead free, RoHS compliant.



UNLESS OTHERWISE SPECIFIED
 ALL DIMENSIONS ARE MILLIMETERS
 TOLERANCES: EXCEPT AS NOTED
 HOLES
 MM
 .X ± .25
 .XX ± .15 Ø.XX ± .013
 .XXX ± .05

ADAM TECH

909 Rahway Avenue, Union, NJ 07083
 Phone: 908-687-5000 Fax: 908-687-5710

APPROVALS		DATE
DRAWN	HR	3/30/16
CHECKED	CK	3/30/16
APPROVED		

TITLE			
SMT SPRING LOADED PIN, STRAIGHT			
SIZE	PART NO.	REV.	
X	PH-MVF-XXXX	A	
REF:	S00170C	SCALE: NTS	SHEET 1 OF 2

6 5 4 3 2 1

APPROVED: _____
DATE: _____ TITLE: _____

Rev	AWO #	Description	Date	Appr
SEE SHT 1 OF 2 FOR REVISION				

ADAM P/N	Initial Height
PH-MVF-7390	9.0mm
PH-MVF-73A0	10.0mm
PH-MVF-73B0	11.0mm

Working Stroke	Spring Force
1.0mm	70g

Rated Current	Rated Voltage
3A Max	12V

ADAM P/N	Initial Height
PH-MVF-A3C0	12.0mm
PH-MVF-A3D0	13.0mm
PH-MVF-A3E0	14.0mm

Working Stroke	Spring Force
1.0mm	70g

Rated Current	Rated Voltage
3A Max	12V

ADAM P/N	Initial Height
PH-MVF-C3F0	15.0mm

Working Stroke	Spring Force
1.0mm	70g

Rated Current	Rated Voltage
3A Max	12V

UNLESS OTHERWISE SPECIFIED
ALL DIMENSIONS ARE MILLIMETERS
TOLERANCES: EXCEPT AS NOTED HOLES

MM HOLES

.X ± .25
.XX ± .15 ∅.XX ± .013
.XXX ± .05

ADAM TECH
909 Rahway Avenue, Union, NJ 07083
Phone: 908-687-5000 Fax: 908-687-5710

APPROVALS		DATE
DRAWN	HR	3/30/16
CHECKED	CK	3/30/16
APPROVED		

TITLE SMT SPRING LOADED PIN, STRAIGHT		
SIZE X	PART NO. PH-MVF-XXXX	REV. A
REF: S00170C	SCALE: NTS	SHEET 2 OF 2

6 5 4 3 2 1