



Is Now Part of



ON Semiconductor®

To learn more about ON Semiconductor, please visit our website at
www.onsemi.com

Please note: As part of the Fairchild Semiconductor integration, some of the Fairchild orderable part numbers will need to change in order to meet ON Semiconductor's system requirements. Since the ON Semiconductor product management systems do not have the ability to manage part nomenclature that utilizes an underscore (_), the underscore (_) in the Fairchild part numbers will be changed to a dash (-). This document may contain device numbers with an underscore (_). Please check the ON Semiconductor website to verify the updated device numbers. The most current and up-to-date ordering information can be found at www.onsemi.com. Please email any questions regarding the system integration to Fairchild_questions@onsemi.com.

ON Semiconductor and the ON Semiconductor logo are trademarks of Semiconductor Components Industries, LLC dba ON Semiconductor or its subsidiaries in the United States and/or other countries. ON Semiconductor owns the rights to a number of patents, trademarks, copyrights, trade secrets, and other intellectual property. A listing of ON Semiconductor's product/patent coverage may be accessed at www.onsemi.com/site/pdf/Patent-Marking.pdf. ON Semiconductor reserves the right to make changes without further notice to any products herein. ON Semiconductor makes no warranty, representation or guarantee regarding the suitability of its products for any particular purpose, nor does ON Semiconductor assume any liability arising out of the application or use of any product or circuit, and specifically disclaims any and all liability, including without limitation special, consequential or incidental damages. Buyer is responsible for its products and applications using ON Semiconductor products, including compliance with all laws, regulations and safety requirements or standards, regardless of any support or applications information provided by ON Semiconductor. "Typical" parameters which may be provided in ON Semiconductor data sheets and/or specifications can and do vary in different applications and actual performance may vary over time. All operating parameters, including "Typicals" must be validated for each customer application by customer's technical experts. ON Semiconductor does not convey any license under its patent rights nor the rights of others. ON Semiconductor products are not designed, intended, or authorized for use as a critical component in life support systems or any FDA Class 3 medical devices or medical devices with a same or similar classification in a foreign jurisdiction or any devices intended for implantation in the human body. Should Buyer purchase or use ON Semiconductor products for any such unintended or unauthorized application, Buyer shall indemnify and hold ON Semiconductor and its officers, employees, subsidiaries, affiliates, and distributors harmless against all claims, costs, damages, and expenses, and reasonable attorney fees arising out of, directly or indirectly, any claim of personal injury or death associated with such unintended or unauthorized use, even if such claim alleges that ON Semiconductor was negligent regarding the design or manufacture of the part. ON Semiconductor is an Equal Opportunity/Affirmative Action Employer. This literature is subject to all applicable copyright laws and is not for resale in any manner.

FSA8108

Audio Jack Detection Solution Featuring Volume Up/Down & Send/End Detection

Features

- Detection:
 - Accessory Plug-In
 - Send / End Key Press
 - Volume Up/Down Key Press
- V_{DD} 2.7 to 4.5 V
- V_{IO} 1.6 V to V_{DD}
- THD (MIC) 0.01% Typical
- LDO Output for MIC Bias Voltage: 2.4 V
- ESD (IEC 61000-4-2) 15 kV Air Gap
- Detects 3- or 4-Pole Audio Accessories
- Removes Audio Jack Pop-and-Click Caused by MIC Bias

Description

The FSA8108 is an audio jack detection switch for 3- or 4-pole accessories that detects the audio plug connection. The FSA8108 detects volume up/down or send/end key presses. An LDO provides DC bias to microphone and remote key circuit in the accessory. For system flexibility, the FSA8108 features an I²C port with registers to allow programmability of AC timing specifications.

Applications

- Cellular Phones, Smart Phones
- MP3 and PMP (Portable Media Player)

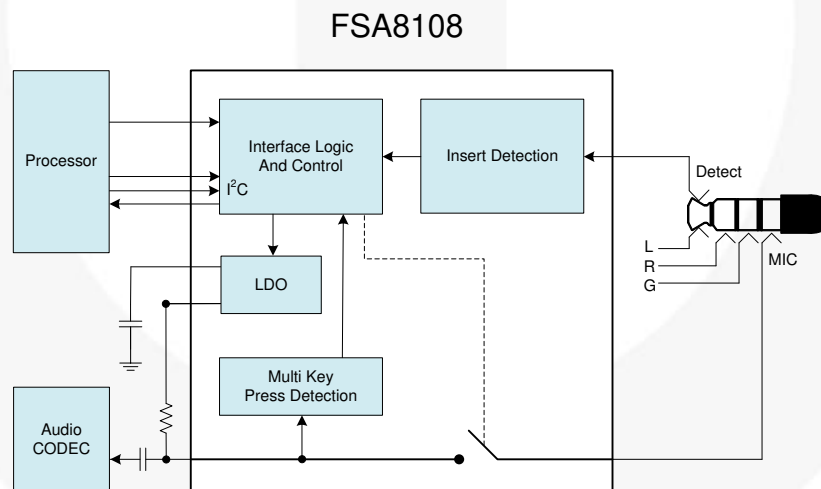

Figure 1. Typical Application Diagram

Ordering Information

Part Number	Operating Temperature Range	Top Mark	Package
FSA8108BUCX ⁽¹⁾	-40 to +85°C	G6	12-Ball, 3 x 4 Array, 0.4 mm Pitch, 250 μm Ball, Wafer-Level Chip-Scale Package

Note:

1. Includes backside lamination.

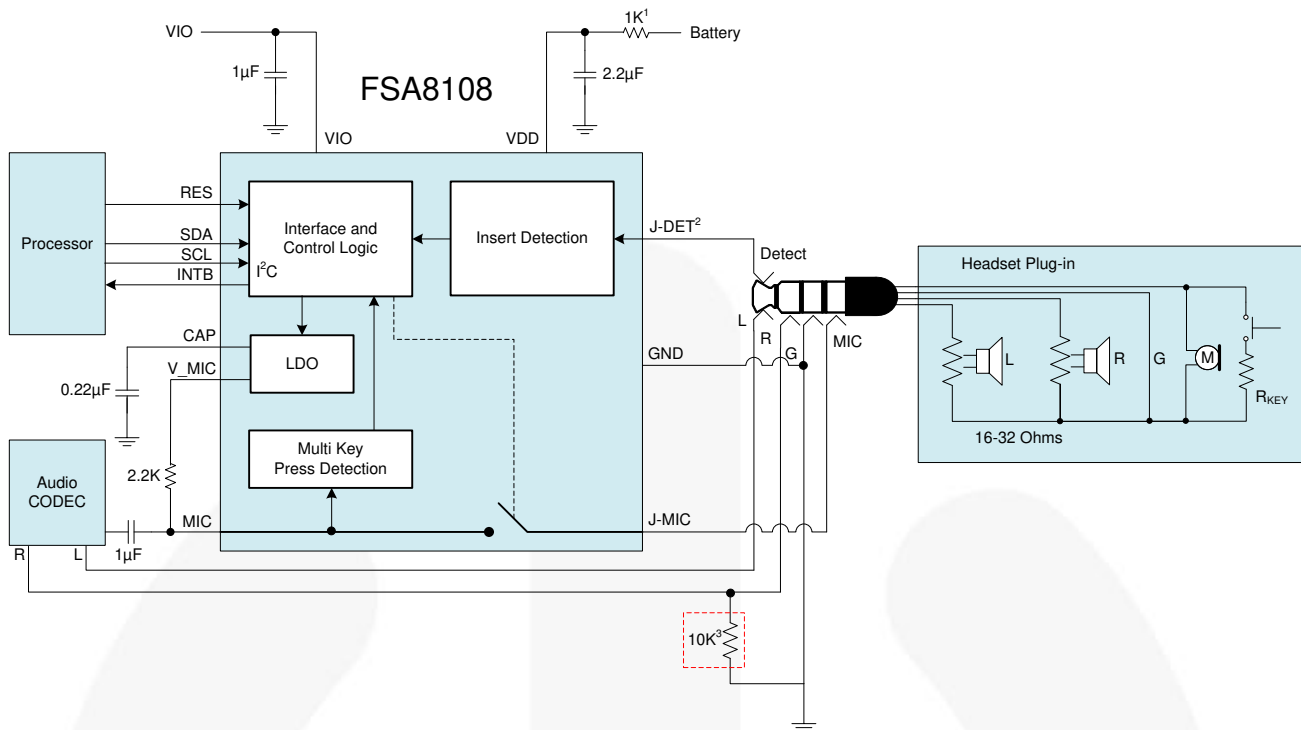

Figure 2. Typical Application Diagram

Notes:

2. A 1 kΩ resistor with a 2.2 µF capacitor is recommended for direct battery connection. This filter helps stabilize power rail events not associated with the FSA8039A. If power is supplied from a stable source, such as from a PMIC or LDO, a single 1 µF capacitor is recommended.
3. The J-DET is shorted to the left (L) audio channel when the headset or accessory plug is inserted into most audio jacks. Any external circuitry attached to the J-DET pin could affect audio performance in the 20-20 kHz range on the left channel.
4. The optional 10 kΩ resistor on the left channel is used to assist in detection of high-impedance accessories. This resistor has negligible impact on audio fidelity.

Pin Configuration

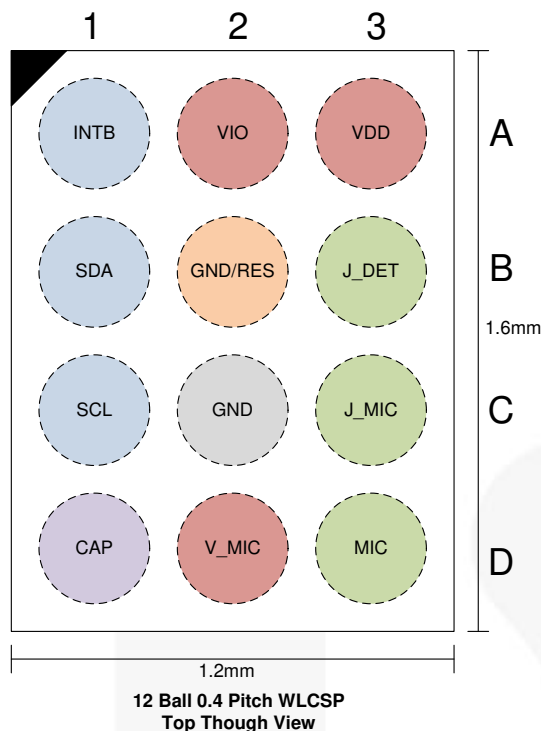

Figure 3. Pin Assignments

Pin Definitions

Name	PIN	Type	Description
INTB	A1	Output	Interrupt. Low is interrupt asserted.
SDA	B1	Data	I ² C data
SCL	C1	Data	I ² C input clock
CAP	D1	Output	Internal LDO output. A capacitor to ground is required.
VIO	A2	Power	Baseband I/O supply voltage
RES	B2	Input	Device reset control. Active high reset. Connect to GND if unused.
GND	C2	GND	Ground
V_MIC	D2	Power	LDO output to supply MIC bias voltage (2.4 V)
VDD	A3	Power	Core supply voltage
J_DET	B3	I/O	Input from a pin of the audio jack socket; plug insert/removal detection pin.
J_MIC	C3	I/O	Microphone switch path that connects to the audio jack.
MIC	D3	I/O	Microphone switch path that goes to the microphone input of the codec.

Application Information

Music Mode

When a 4-pole headset is inserted into the audio jack and a music/listening application is used, the MIC bias is normally enabled for headset button press detection (i.e. mute, volume change, etc.). This consumes power due to a constant path from the MIC bias resistor and microphone in the headset to GND. Fairchild has developed a Music Mode to enable the MIC switch periodically to monitor for a pressed button. This results in a power savings for battery-sensitive devices, such as cell phones or MP3 players. The FSA8108 enters Music Mode when the Music Mode Enable bit in CONTROL(0Ch) is set and a plug is inserted. Music Mode reduces MIC bias current by approximately 80% with the default Music Mode timing (09h) register value.

LDO Operation

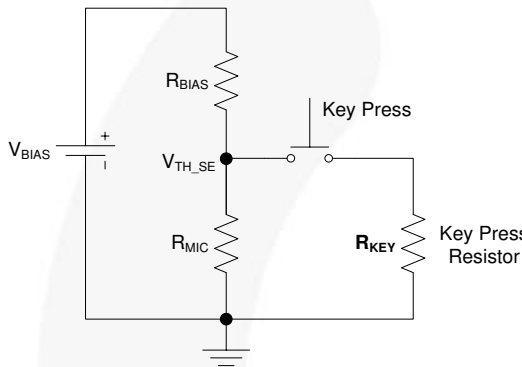

$$R_{VOL\ UP\ KEY\ MIN} = \frac{1}{\left(\frac{V_{BIAS_MAX} - V_{TH_KEY_MIN}}{V_{TH_KEY_MIN}}\right) \frac{1}{R_{BIAS}} - \frac{1}{R_{MIC}}}$$

$$= 132\Omega$$

$$R_{VOL\ UP\ KEY\ MAX} = \frac{1}{\left(\frac{V_{BIAS_MIN} - V_{TH_KEY_MAX}}{V_{TH_KEY_MAX}}\right) \frac{1}{R_{BIAS}} - \frac{1}{R_{MIC}}}$$

$$= 286\Omega$$

Volume up Resistor
V_{BIAS}, LDO ±5%, 2.28V – 2.25V
R_{BIAS}=2.2kΩ
R_{MIC}=2kΩ
V_{TH_KEY_Min}:120mV default +12%, 0.134V
Max: 250mV default-7%, 0.233V

Figure 4. Example Key-Press Resistor Calculations and Values

Absolute Maximum Ratings

Stresses exceeding the absolute maximum ratings may damage the device. The device may not function or be operable above the recommended operating conditions and stressing the parts to these levels is not recommended. In addition, extended exposure to stresses above the recommended operating conditions may affect device reliability. The absolute maximum ratings are stress ratings only.

Symbol	Parameter	Min.	Max.	Unit	
V_{DD}, V_{IO}	Supply Voltage from Battery	-0.5	6.0	V	
V_{SW}	Switch I/O Voltage	-0.5	$V_{CC}+0.5$	V	
I_{V_MIC}	V_MIC LDO Supply Current		15	mA	
I_{IK}	Input Clamp Diode Current	-50		mA	
I_{SW}	Switch I/O Current		50	mA	
T_{STG}	Storage Temperature Range	-65	+150	°C	
T_J	Maximum Junction Temperature		+150	°C	
T_L	Lead Temperature (Soldering, 10 Seconds)		+260	°C	
ESD	IEC 61000-4-2 System ESD	Air Gap		15	kV
		Contact		8	
	Human Body Model, JEDEC JESD22-A114	J_DET vs. GND, J_MIC vs. GND, VDD vs. GND, VIO vs. GND		11	
		All Pins		4	
	Charged Device Model, JEDEC JESD22-C101	All Pins		2	

Recommended Operating Conditions

The Recommended Operating Conditions table defines the conditions for actual device operation. Recommended operating conditions are specified to ensure optimal performance to the datasheet specifications. Fairchild does not recommend exceeding them or designing to Absolute Maximum Ratings.

Symbol	Parameter	Min.	Max.	Unit
V_{DD}	Supply Voltage	2.7	4.5	V
V_{IO}	I/O Supply Voltage	1.6	V_{DD}	V
T_A	Operating Temperature	-40	+85	°C
V_{IN}	MIC Switch Input Voltage Range	0	V_{DD}	V
V_{Audio}	Audio Voltage Range on J_DET Pin	-1	1	V
f_{Audio}	Audio Frequency on J_DET Pin	20	20000	Hz
J_DET_{RL}	Resistance on Audio Accessory Left Channel to generate Attach		500	k Ω

DC Electrical Characteristics

All typical values are at $T_A=25^\circ\text{C}$ unless otherwise specified.

Symbol	Parameter	V_{DD} (V)	Condition	$T_A=-40$ to $+85^\circ\text{C}$			Unit
				Min.	Typ.	Max.	
MIC Switch							
R_{ON}	MIC Switch On Resistance	3.8	$I_{OUT}=24\text{ mA}$, $V_{IN}=2.0\text{ V}$		0.8	2.5	Ω
R_{FLAT}	On Resistance Flatness	3.8	$I_{OUT}=24\text{ mA}$, $V_{IN}=1\text{ V}$ to V_{DD}		0.7		Ω
$C_{ON(MIC)}$	MIC Switch On Capacitance	3.8	$f=1\text{ MHz}$, $V_{IN}=100\text{ mV}$, 50 mV_{PP}		16		pF
$C_{OFF(MIC)}$	MIC Switch Off Capacitance	3.8	$f=1\text{ MHz}$, $V_{IN}=100\text{ mV}$, 50 mV_{PP}		30		pF
J-DET							
J_DET_{HYS}	Hysteresis of J_DET				200		mV
Parallel I/O Control Signals							
V_{IL}	Low-Level Input Voltage					$0.3 \cdot V_{IO}$	V
V_{IH}	High-Level Input Voltage			$0.7 \cdot V_{IO}$		V_{IO}	V
I²C Controller DC Characteristics Fast Mode (400 kHz)							
V_{IL}	Low-Level Input Voltage			-0.5		$0.3 V_{IO}$	V
V_{IH}	High-Level Input Voltage			$0.7 V_{IO}$			V
V_{HYS}	Hysteresis of Schmitt Trigger Inputs		$V_{IO}>2\text{ V}$			$0.05 V_{IO}$	V
			$V_{IO}<2\text{ V}$			$0.1 V_{IO}$	
V_{OL1}	Output Voltage (Open-Drain)		$V_{IO}>2\text{ V}$, 3 mA	0		0.4	V
			$V_{IO}<2\text{ V}$, 3 mA			$0.2 V_{IO}$	V
I_{2C}	Input Current of SDA and SCL Pins, Input Voltage 0.26 V to 2.34 V			-10		10	μA
C_I	Capacitance for Each I/O Pin ⁽⁵⁾					10	pF
Current Consumption							
I_{OZ}	Off Leakage Current	4.5	MIC and J_MIC Port $V_{IN}=4.4\text{ V}$			1.5	μA
I_{IN}	Input Leakage Current	0 to 4.5	Inputs 0 to 4.4 V		1		μA
$I_{DD-SLNA}$	Sleep Mode Current with No Accessory	2.7 to 4.5	$J_DET=1$		1.5		μA
$I_{DD-SLWA}$	Current After Detection With Accessory (Normal Mode)	2.7 to 4.5	$J_DET=0$		35		μA
$I_{DD-MUSIC\ MODE}$	Music Mode	2.7 to 4.5	I ² C Default Settings		25		μA
I_{DD_LDO}	Current to Operating LDO, Not Including Output Current	2.7 to 4.5	LDO Powered		110		μA
$I_{DD-SLWA + LDO}$	Current After Detection With Accessory (Normal Mode) with LDO Current	2.7 to 4.5	$J_DET=0$		145		μA
$I_{DD_Music\ Mode + LDO}$	Music Mode with LDO	2.7 to 4.5	I ² C Default Settings		135		μA

Continued on the following page...

DC Electrical Characteristics

All typical values are at $T_A=25^\circ\text{C}$ unless otherwise specified.

Symbol	Parameter	V_{DD} (V)	Condition	$T_A=-40$ to $+85^\circ\text{C}$			Unit
				Min.	Typ.	Max.	
MIC_V LDO Outputs							
MIC_V _{VOUT}	Output Voltage	2.7 to 4.5		-5%	2.4	+5%	V
MIC_V _{IOUT}	Maximum Output Current	2.7 to 4.5		10			mA
Comparator Thresholds for Headset Key Pad (Default Voltage Reference)							
V _{COMP1}	Comparator Threshold for Send/End Sensing for NO Headset	2.7 to 4.5	I ² C Default Setting, V _{MIC} =2.4 V, R _{MIC} =2.2 k Ω	-12%	120	+12%	mV
V _{COMP2}	Comparator Threshold for Send/End Sensing for NC Headset	2.7 to 4.5	I ² C Default Setting, V _{MIC} =2.4 V, R _{MIC} =2.2 k Ω	-5%	2300	+5%	mV
V _{COMP3}	Comparator Threshold for Volume_Up Sensing	2.7 to 4.5	I ² C Default Setting, V _{MIC} =2.4 V, R _{MIC} =2.2 k Ω	-7%	250	+7%	mV
V _{COMP4}	Comparator Threshold for Volume_Down Sensing	2.7 to 4.5	I ² C Default Setting, V _{MIC} =2.4 V, R _{MIC} =2.2 k Ω	-7%	690	+7%	mV

Note:

5. Not production tested.

AC Electrical Characteristics

All typical values are at $T_A=25^\circ\text{C}$ unless otherwise specified; all other values are at the recommended T_A and T_J temperatures. Not production tested.

Symbol	Parameter	V_{DD} (V)	Condition	$T_A=-40$ to $+85^\circ\text{C}$			Unit
				Min.	Typ.	Max.	
MIC Switch							
THD	Total Harmonic Distortion	3.8	$R_T=600\ \Omega$, $V_{SW}=0.5\ V_{PP}$, $f=20\ \text{Hz}$ to $20\ \text{kHz}$, $V_{IN}=2.0\ \text{V}$		0.01		%
O_{IRR}	Off Isolation	3.8	$f=20\ \text{kHz}$, $R_S=600\ \Omega$, $C_L=0\ \text{pF}$, $R_T=600\ \Omega$		80		dB
Parallel I/O (Default Timing)							
t_{ON}	Switch Turn-On Time	3.8	$R_L=10\ \text{k}\Omega$, $C_L=10\ \text{pF}$		100		μs
t_{OFF}	Switch Turn-Off Time	3.8	$R_L=10\ \text{k}\Omega$, $C_L=10\ \text{pF}$		10		ns
t_{DET-IN}	Debounce Time after J_DET Changes from HIGH to LOW	2.7 to 4.5	I ² C Default Setting		500		ms
$t_{DET-REM}$	Debounce Time after J_DET Changes from Low to HIGH	2.7 to 4.5	I ² C Default Setting		30		μs
$t_{DET-MIC}$	Detection Time of Audio Jack GND and MIC Terminals	2.7 to 4.5	I ² C Default Setting		50		ms
t_{ESD_DE}	Debounce Time for ESD Event on J_DET (Double-Check J_DET Status)	2.7 to 4.5	I ² C Default Setting		1		ms
t_{POLL}	ON Time of MIC Switch for Sensing SEND/END Key Press in MP3 Mode	2.7 to 4.5	I ² C Default Setting		15		ms
t_{WAIT}	OFF Time of MIC Switch for Sensing SEND/END Key Press in MP3 Mode	2.7 to 4.5	I ² C Default Setting		150		ms
$t_{K BK}$	Debounce Time for Sensing SEND/END Key Press/Release	2.7 to 4.5	I ² C Default Setting		45		ms
$t_{KEY-LONG}$	Minimum Time for Long Key Press	2.7 to 4.5	I ² C Default Setting		900		ms
$t_{KEY-Double}$	Maximum Time between Key Presses for Double-Key Press	2.7 to 4.5	I ² C Default Setting		1000		ms
t_{RES_DE}	Debounce Time for Reset Control	2.7 to 4.5			15		μs
Power Supply Noise Immunity							
$PSRR_{SW}$	Power Supply Rejection Ratio for Switch	3.8	Power Supply Noise 300 mV _{PP} , Measured 10/90%, $f=217\ \text{Hz}$		95		dB
$PSRR_{LDO}$	Power Supply Rejection Ratio for LDO	3.8	Power Supply Noise 300 mV _{PP} , Measured 10/90%, $f=217\ \text{Hz}$, $C_{EXT}=1\ \mu\text{F}$		100		dB

I²C Specifications (Fast Mode)

Symbol	Parameter	Min.	Max.	Unit
f _{SCL}	SCL Clock Frequency	0	400	kHz
t _{HD;STA}	Hold Time (Repeated) START Condition	0.6		μs
t _{LOW}	LOW Period of SCL Clock	1.3		μs
t _{HIGH}	HIGH Period of SCL Clock	0.6		μs
t _{SU;STA}	Set-up Time for Repeated START Condition	0.6		μs
t _{HD;DAT}	Data Hold Time	0	0.9	μs
t _{SU;DAT}	Data Set-up Time ⁽⁶⁾	100		ns
t _r	Rise Time of SDA and SCL Signals ^(6,7)	20+0.1C _b	300	ns
t _f	Fall Time of SDA and SCL Signals ^(6,7)	20+0.1C _b	300	ns
t _{SU;STO}	Set-up Time for STOP Condition	0.6		μs
t _{BUF}	BUS-Free Time between STOP and START Conditions	1.3		μs
t _{SP}	Pulse Width of Spikes that Must Be Suppressed by the Input Filter	0	50	ns

Notes:

- A Fast-Mode I²C-Bus® device can be used in a Standard-Mode I²C-Bus system; but the requirement t_{SU;DAT} ≥ 250 ns must be met. This is automatically the case if the device does not stretch the LOW period of the I2C_SCL signal. If the device does stretch the LOW period of the I2C_SCL signal, it must output the next data bit to the I2C_SDA line t_{r,max} + t_{SU;DAT} = 1000 + 250 = 1250 ns (according to the Standard-Mode I²C Bus specification) before the I2C_SCL line is released.
- C_b equals the total capacitance of one BUS line in pF. If mixed with high-speed devices, faster fall times are allowed according to the I²C specification.

I²C Timing

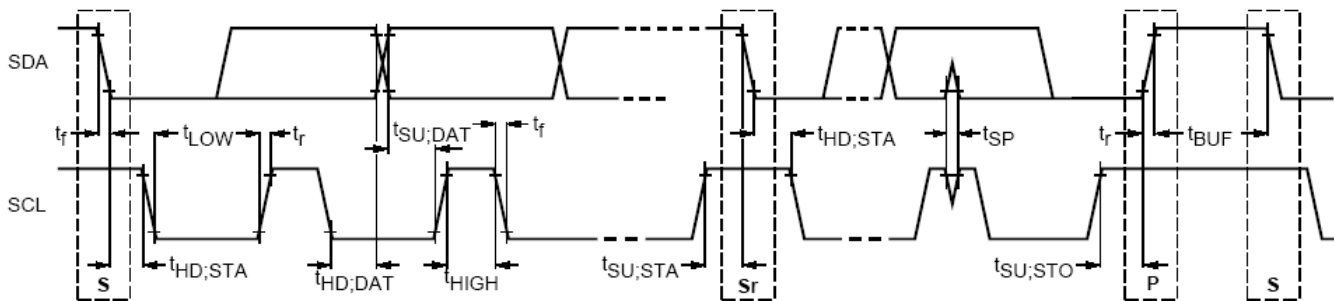

Figure 5. Definition of Timing for Full-Speed Mode Devices on the I²C Bus

Name	Size(Bits)	Bit 7	Bit 6	Bit 5	Bit 4	Bit 3	Bit 2	Bit 1	Bit 0
Slave Address	8	0	1	0	0	0	1	1	Read/White

Figure 6. I²C Slave Address

Table 1. Register Definitions

Address	Register	Type	Reset Values	Bit 7	Bit 6	Bit 5	Bit 4	Bit 3	Bit 2	Bit 1	Bit 0	
01H	Device ID	R	00000000	Version ID				Reserved				
02H	Interrupt 1	R	00000000	Reserved		Send/End Long Key Press	Send/End Double Key Press	Send/End Key Press	Plug Disconnect	4-Pole Plug Connect	3-Pole Plug Connect	
03H	Interrupt 2	R	00000000	Reserved		Volume Down Long Key release	Volume Down Long Key Press	Volume Down Key Press	Volume Up Long Key release	Volume Up Long Key Press	Volume Up Key Press	
04H	Interrupt Mask 1	R/W	00000000	Reserved		Send/End Long Key Press Mask	Send/End Double Key Press Mask	Send/End Key Press Mask	Plug Disconnect Mask	4-Pole Plug Connect Mask	3-Pole Plug Connect Mask	
05H	Interrupt Mask 2	R/W	00000000	Reserved		Volume Down Long Key release Mask	Volume Down Long Key Press Mask	Volume Down Key Press Mask	Volume Up Long Key Release Mask	Volume Up Long Key Press Mask	Volume Up Key Press Mask	
06H	Global Multiplier	R/W	00000100	Reserved					Global Multiplier Number			
07H	J_DET Timing	R/W	10000010	Insert (t_{DET-IN})				Removal ($t_{DET-REM}$) Global Multiplier Does not apply				
08H	Key Press Timing	R/W	01111000	Double Key Press Timing ($t_{KEY-DOUBLE}$)				Long Key Press Timing ($t_{KEY-LONG}$)				
09H	Music Mode Timing	R/W	00101000	Key Press Polling Time (t_{POLL})				Key Press Waiting Time (t_{WAIT})				
0AH	Detection Timing	R/W	01010101	Key Press timing for volume up and volume down (t_{KEY_PRESS})				Detection Time ($t_{DET-MIC}$)				
0BH	Debounce Timing	R/W	10011000	Debounce for ESD Event on J_DET (t_{ESD_DE})				Key Press Debounce Timing (t_{KBK})				
0CH	Control	R/W	01001000	Stuck S/E On/Off	All Key as Send/End On/Off	Double Key Press On/Off	Long Key Press On/Off	Music Mode	Jack Det On/Off	3/ 4-Pole Det On/Off	LDO Output On/Off	
0DH	Detection Thresholds	R/W	11101010	Comparator 2 (Send/End Key - Normally Closed)				Comparator 1 (Send/End Key - Normally Open)				
0EH	Detection Thresholds	R/W	01111001	Comparator 4 (Volume Down)				Comparator 3 (Volume Down)				
0FH	Reset Control	R/W	00000000	Reserved							Jack Removal Reset	Global Reset
10H	Reserved	R/W	Reserved	Reserved								

Notes:

8. Write "0" to undefined register bits.
9. Values read from undefined register bits are not defined and are invalid.
10. Blocks in green color mean setting change is implemented upon next use.
11. Blocks in blue color mean setting change is implemented after jack removal.

Table 2. I²C Control

Reserved Register bit read out as 0
 Address: 01H
 Reset Value: 00000000
 Type: Read

Device ID			Default	00000000
Bit #	Name	Size	Function	
0:3	Reserved	4	Do Not Use	
4:7	Version ID	4	0000 = Version 0.0	
			0001 = Version 0.1	

Table 3. Interrupt 1

Address: 02H
 Reset Value: 00000000
 Type: Read/Clear

Interrupt 1			Default	00000000
Bit #	Name	Size	Function	
0	3-Pole Plug Connect	1	0: No Headset Connected	
			1: 3-Pole Headset Connected	
1	4-Pole Plug Connect	1	0: No Headset Connected	
			1: 4-Pole Headset Connected	
2	Plug Disconnect	1	0: No Update	
			1: Headset Disconnected	
3	Send/End Key Press	1	0: Send/End Key Not Pressed	
			1: Send/End Key Pressed	
4	Send/End Double Key Press	1	0: Send/End Double Key Not Pressed	
			1: Send/End Double Key Pressed	
5	Send/End Long Key Press	1	0: Send/End Long Key not Pressed	
			1: Send/End Long Key Pressed	
6:7	Reserved	2	Do Not Use	

Table 4. Interrupt 2

Address: 03H
 Reset Value: 00000000
 Type: Read/Clear

Interrupt 2			Default	00000000
Bit #	Name	Size	Function	
0	Volume Up Key Press	1	0: Volume Up key not pressed	
			1: Volume Up key pressed	
1	Volume Up Key Long Press	1	0: Volume Up Long key not pressed	
			1: Volume Up Long key pressed	
2	Volume Up Key Long Release	1	0: Volume Up Long key not released	
			1: Volume Up Long key released	
3	Volume Down Key Press	1	0: Volume Down key not pressed	
			1: Volume Down Key Press	
4	Volume Down Long Key Press	1	0: Volume Down Long Key Not Pressed	
			1: Volume Down Long Key Pressed	
5	Volume Down Long Key Release	1	0: Volume Down Key Not Released	
			1: Volume Down Key Released	
6:7	Reserved	2	Do Not Use	

Table 5. Interrupt Mask 1

Address: 04H

Reset Value: 00000000

Type: Read/Write

Interrupt Mask 1			Default	00000000
Bit #	Name	Size	Function	
0	3-Pole Plug Connect	1	0: Do Not Mask 3-Pole Plug Connect Interrupt	
			1: Mask 3-Pole Plug Connect Interrupt	
1	4-Pole Plug Connect	1	0: Do Not Mask 4-Pole Plug Connect Interrupt	
			1: Mask 4-Pole Plug Connect Interrupt	
2	Plug Disconnect	1	0: Do Not Mask Plug Disconnect Interrupt	
			1: Mask Plug Disconnect Interrupt	
3	Send/End Key Press	1	0: Do Not Mask Send/End Key Press Interrupt	
			1: Mask Send/End Key Press Interrupt	
4	Send/End Double Key Press	1	0: Do Not Mask Send/End Key Double Press Interrupt	
			1: Mask Send/End Key Double Key Press Interrupt	
5	Send/End Long Key Press	1	0: Do Not Mask Send/End Long Key Press Interrupt	
			1: Mask Send/End Long Key Press Interrupt	
6:7	Reserved	2	Do Not Use	

Table 6. Interrupt Mask 2

Address: 05H

Reset Value: 00000000

Type: Read/Write

Interrupt Mask 2			Default	00000000
Bit #	Name	Size	Function	
0	Volume Up Key Press	1	0: Do Not Mask Volume Up Key Press Interrupt	
			1: Mask Volume Up Key Press Interrupt	
1	Volume Up Key Long Press	1	0: Do Not Mask Volume Up Long Key Press Interrupt	
			1: Mask Volume Up Long Key Press Interrupt	
2	Volume Up Key Long Release	1	0: Do Not Mask Volume Up Long Key Release Interrupt	
			1: Mask Volume Up Long Key Release Interrupt	
3	Volume Down Key Press	1	0: Do Not Mask Volume Down Key Press Interrupt	
			1: Mask Volume Down Key Press Interrupt	
4	Volume Down Long Key Press	1	0: Do Not Mask Volume Down Long Key Press Interrupt	
			1: Mask Volume Down Long Key Press Interrupt	
5	Volume Down Long Key Release	1	0: Do Not Mask Volume Down key Release Interrupt	
			1: Mask Volume Down key released Interrupt	
6:7	Reserved	2	Do Not Use	

Table 7. Global Multiplier Number

Address: 06H

Reset Value: 00000100

Type: Read/Write

Global Multiplier Number								Default	00000100
Bit 7	Bit 6	Bit 5	Bit 4	Bit 3	Bit 2	Bit 1	Bit 0	Function	
Reserved					0	0	0	1/16	
Reserved					0	0	1	1/8	
Reserved					0	1	0	1/4	
Reserved					0	1	1	1/2	
Reserved					1	0	0	1	
Reserved					1	0	1	2	
Reserved					1	1	0	4	
Reserved					1	1	1	8	

Table 8. J_DET Timing

Address: 07H

Reset Value: 10000010

Type: Read/Write

J_DET Timing										Default	10000010
Insert (t_{DET_IN})					Removal (t_{DET_REM}) (Global Multiplier Does Not Apply)						
Bit 7	Bit 6	Bit 5	Bit 4	Function	Bit 3	Bit 2	Bit 1	Bit 0	Function		
0	0	0	0	100	0	0	0	0	10		
0	0	0	1	150	0	0	0	1	20		
0	0	1	0	200	0	0	1	0	30		
0	0	1	1	250	0	0	1	1	40		
0	1	0	0	300	0	1	0	0	50		
0	1	0	1	350	0	1	0	1	60		
0	1	1	0	400	0	1	1	0	70		
0	1	1	1	450	0	1	1	1	80		
1	0	0	0	500	1	0	0	0	90		
1	0	0	1	550	1	0	0	1	100		
1	0	1	0	600	1	0	1	0	110		
1	0	1	1	650	1	0	1	1	120		
1	1	0	0	700	1	1	0	0	130		
1	1	0	1	750	1	1	0	1	140		
1	1	1	0	800	1	1	1	0	140		
1	1	1	1	850	1	1	1	1	140		

Table 9. Key Press Timing

Address: 08H

Reset Value: 01111000

Type: Read/Write

Key Press Timing										Default	00101000
Double Key Press (t_{DOUBLE})					Long Key Press (t_{LONG})						
Bit 7	Bit 6	Bit 5	Bit 4	Function	Bit 3	Bit 2	Bit 1	Bit 0	Function		
0	0	0	0	100	ms	0	0	0	0	500	ms
0	0	0	1	200		0	0	0	1	550	
0	0	1	0	300		0	0	1	0	600	
0	0	1	1	400		0	0	1	1	650	
0	1	0	0	500		0	1	0	0	700	
0	1	0	1	600		0	1	0	1	750	
0	1	1	0	800		0	1	1	0	800	
0	1	1	1	1000		0	1	1	1	850	
1	0	0	0	1100		1	0	0	0	900	
1	0	0	1	1200		1	0	0	1	1000	
1	0	1	0	1300		1	0	1	0	1100	
1	0	1	1	1400		1	0	1	1	1200	
1	1	0	0	1500		1	1	0	0	1300	
1	1	0	1	1600		1	1	0	1	1400	
1	1	1	0	1800		1	1	1	0	1500	
1	1	1	1	2000		1	1	1	1	2000	

Table 10. Music Mode Timing

Address: 09H

Reset Value: 01011000

Type: Read/Write

Music Mode Timing										Default	01011000
Key Press Polling Time (t_{POLL})					Key Press Waiting Time (t_{WAIT})						
Bit 7	Bit 6	Bit 5	Bit 4	Function	Bit 3	Bit 2	Bit 1	Bit 0	Function		
0	0	0	0	5	ms	0	0	0	0	5	ms
0	0	0	1	10		0	0	0	1	10	
0	0	1	0	15		0	0	1	0	15	
0	0	1	1	20		0	0	1	1	20	
0	1	0	0	25		0	1	0	0	25	
0	1	0	1	30		0	1	0	1	30	
0	1	1	0	35		0	1	1	0	50	
0	1	1	1	40		0	1	1	1	100	
1	0	0	0	45		1	0	0	0	150	
1	0	0	1	50		1	0	0	1	200	
1	0	1	0	60		1	0	1	0	250	
1	0	1	1	70		1	0	1	1	300	
1	1	0	0	80		1	1	0	0	350	
1	1	0	1	90		1	1	0	1	400	
1	1	1	0	100		1	1	1	0	450	
1	1	1	1	150		1	1	1	1	500	

Table 11. Detection Timing

Address: 0AH

Reset Value: 01010101

Type: Read/Write

Detection Timing					Default	01010101					
Key Press Timing for Volume Up and Volume Down (t_{KEY})					Detection Time (t_{DET_MIC})						
Bit 7	Bit 6	Bit 5	Bit 4	Function	Bit 3	Bit 2	Bit 1	Bit 0	Function		
0	0	0	0	50	ms	0	0	0	0	5	ms
0	0	0	1	100		0	0	0	1	10	
0	0	1	0	150		0	0	1	0	15	
0	0	1	1	200		0	0	1	1	20	
0	1	0	0	250		0	1	0	0	25	
0	1	0	1	300		0	1	0	1	50	
0	1	1	0	350		0	1	1	0	75	
0	1	1	1	400		0	1	1	1	100	
1	0	0	0	450		1	0	0	0	150	
1	0	0	1	500		1	0	0	1	200	
1	0	1	0	550		1	0	1	0	250	
1	0	1	1	600		1	0	1	1	300	
1	1	0	0	650		1	1	0	0	350	
1	1	0	1	700		1	1	0	1	400	
1	1	1	0	750		1	1	1	0	450	
1	1	1	1	800		1	1	1	1	500	

Table 12. Key Press Debounce Timing

Address: 0BH

Reset Value: 10011000

Type: Read/Write

Key Press Debounce Timing					Default	10011000					
Debounce Timing for ESD Event on J_DET (Global Multiplier Does Not Apply)					Key Press Debounce Timing						
Bit 7	Bit 6	Bit 5	Bit 4	Function	Bit 3	Bit 2	Bit 1	Bit 0	Function		
0	0	0	0	100	μs	0	0	0	0	5	ms
0	0	0	1	200		0	0	0	1	10	
0	0	1	0	300		0	0	1	0	15	
0	0	1	1	400		0	0	1	1	20	
0	1	0	0	500		0	1	0	0	25	
0	1	0	1	600		0	1	0	1	30	
0	1	1	0	700		0	1	1	0	35	
0	1	1	1	800		0	1	1	1	40	
1	0	0	0	900		1	0	0	0	45	
1	0	0	1	1000		1	0	0	1	50	
1	0	1	0	1200		1	0	1	0	55	
1	0	1	1	1400		1	0	1	1	60	
1	1	0	0	1600		1	1	0	0	65	
1	1	0	1	1800		1	1	0	1	70	
1	1	1	0	2000		1	1	1	0	75	
1	1	1	1	5000		1	1	1	1	80	

Table 13. Control 1

Address: 0CH
 Reset Value: 01001000
 Type: Read/Write

Control 1			Default	01001000
Bit #	Name	Size	Function	
0	LDO Output	1	0: LDO Output On 1: LDO Output Off	
1	MIC Detection	1	0: MIC Detection On 1: MIC Detection Off	
2	Jack detection	1	0: Jack Detection On 1: Jack Detection Off	
3	Music Mode	1	0: Music Mode On 1: Music Mode Off	
4	Long Key Press Function	1	0: Long Key Press Function On 1: Long Key Press Function Off	
5	Double Key Press Function	1	0: Double Key Press Function On 1: Double Key Press Function Off	
6	All Key as Send/End Function	1	0: All Key as Send/End Function On 1: All Key as Send/End Function Off	
7	Stuck S/E Function	1	0: Stuck Send/End Function On 1: Stuck Send/End Function OFF	

Table 14. Detection Thresholds 1

Address: 0DH
 Reset Value: 11101010
 Type: Read/Write

Detection Thresholds 1										Default	11101010
Normally Closed S/E Key					Normally Open S/E Key Maximum/Volume up Key Minimum						
Bit 7	Bit 6	Bit 5	Bit 4	Function	Bit 3	Bit 2	Bit 1	Bit 0	Function		
0	0	0	0	1000	0	0	0	0	20		
0	0	0	1	1100	0	0	0	1	30		
0	0	1	0	1200	0	0	1	0	40		
0	0	1	1	1300	0	0	1	1	50		
0	1	0	0	1400	0	1	0	0	60		
0	1	0	1	1500	0	1	0	1	70		
0	1	1	0	1600	0	1	1	0	80		
0	1	1	1	1650	0	1	1	1	90		
1	0	0	0	1700	1	0	0	0	100		
1	0	0	1	1750	1	0	0	1	110		
1	0	1	0	1800	1	0	1	0	120		
1	0	1	1	1900	1	0	1	1	130		
1	1	0	0	2000	1	1	0	0	140		
1	1	0	1	2200	1	1	0	1	150		
1	1	1	0	2300	1	1	1	0	160		
1	1	1	1	2400	1	1	1	1	170		

Table 15. Detection Thresholds 2

Address: 0EH

Reset Value: 01110111

Type: Read/Write

Detection Thresholds 2										Default	01111001
Volume Down Key Maximum					Volume Up Key Maximum/Volume Down Key Minimum						
Bit 7	Bit 6	Bit 5	Bit 4	Function	Bit 3	Bit 2	Bit 1	Bit 0	Function		
0	0	0	0	270	mV	0	0	0	0	110	mV
0	0	0	1	330		0	0	0	1	125	
0	0	1	0	390		0	0	1	0	145	
0	0	1	1	450		0	0	1	1	160	
0	1	0	0	510		0	1	0	0	175	
0	1	0	1	570		0	1	0	1	190	
0	1	1	0	630		0	1	1	0	205	
0	1	1	1	690		0	1	1	1	220	
1	0	0	0	750		1	0	0	0	235	
1	0	0	1	810		1	0	0	1	250	
1	0	1	0	870		1	0	1	0	265	
1	0	1	1	930		1	0	1	1	280	
1	1	0	0	990		1	1	0	0	295	
1	1	0	1	1050		1	1	0	1	310	
1	1	1	0	1120		1	1	1	0	325	
1	1	1	1	1190		1	1	1	1	340	

Table 16. Reset Control

Address: 0FH

Reset Value: 00000000

Type: Read/Write

Reset Control			Default	00000000
Bit #	Name	Size	Function	
0	Global Reset	1	0: No Change 1: Reset Device Reset to all I2C into default values (timing, comparator threshold)	
1	Jack Removal Reset	1	0: No Change 1: Clear I2C register related to Jack Removal process (interrupt)	
2:7	Reserved	5	Do Not Use	

Nominal Values

Bump Pitch	Overall Package Height	Silicon Thickness	Solder Bump Height	Solder Bump Diameter
0.4 mm	0.586 mm	0.378 mm	0.208 mm	0.260 mm

Package Specific Dimensions

D	E	X	Y
1.56 mm	1.16 mm	0.18 mm	0.18 mm

REVISIONS			
REV	DESCRIPTION	DATE	APP'D / SITE
1	Initial drawing release.	8-19-09	L. England / FSME

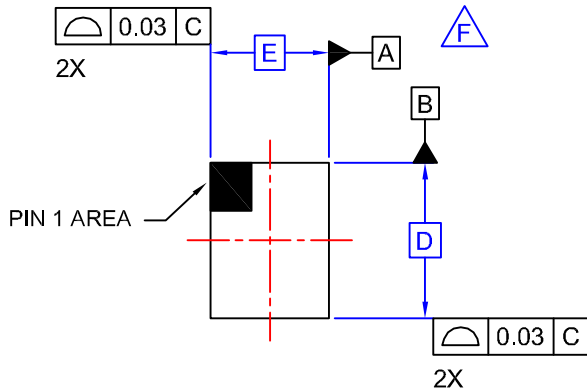

TOP VIEW

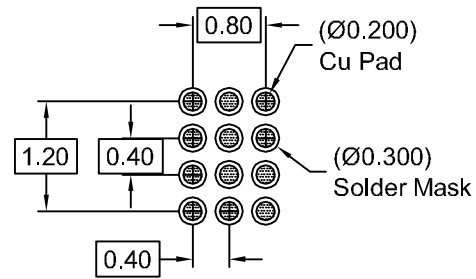

RECOMMENDED LAND PATTERN
(NSMD PAD TYPE)

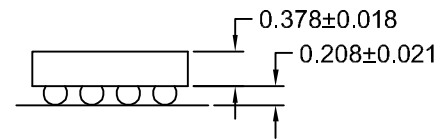
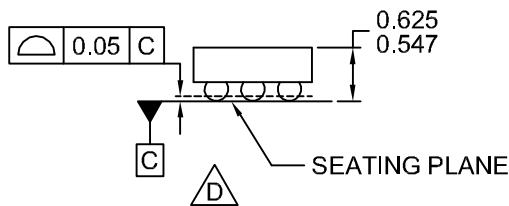

SIDE VIEWS

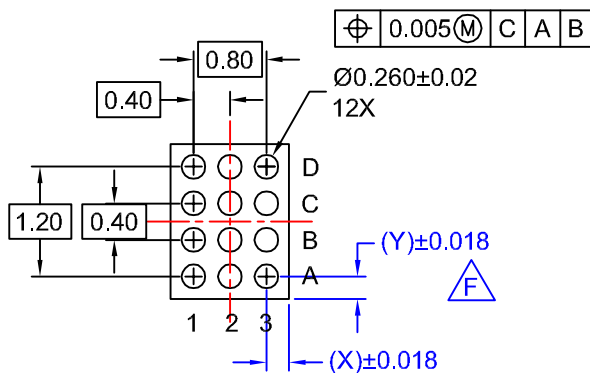

BOTTOM VIEW

NOTES:

- A. NO JEDEC REGISTRATION APPLIES.
- B. DIMENSIONS ARE IN MILLIMETERS.
- C. DIMENSIONS AND TOLERANCES PER ASME Y14.5M, 1994.
- D. DATUM C IS DEFINED BY THE SPHERICAL CROWNS OF THE BALLS.
- E. PACKAGE NOMINAL HEIGHT IS 586 MICRONS ±39 MICRONS (547-625 MICRONS).
- F. FOR DIMENSIONS D, E, X, AND Y SEE PRODUCT DATASHEET.
- G. DRAWING FILENAME: MKT-UC012ACrev1.

APPROVALS		DATE	FAIRCHILD SEMICONDUCTOR™			
DRAWN	L. England	8-19-09	12BALL WLCSP, 3X4 ARRAY 0.4MM PITCH, 250UM BALL			
DFTG. CHK.	S. Martin	8-19-09				
ENGR. CHK.						
			SCALE	SIZE	DRAWING NUMBER	REV
			N/A	N/A	MKT-UC012AC	1
			DO NOT SCALE DRAWING		SHEET 1 of 1	

ON Semiconductor and  are trademarks of Semiconductor Components Industries, LLC dba ON Semiconductor or its subsidiaries in the United States and/or other countries. ON Semiconductor owns the rights to a number of patents, trademarks, copyrights, trade secrets, and other intellectual property. A listing of ON Semiconductor's product/patent coverage may be accessed at www.onsemi.com/site/pdf/Patent-Marking.pdf. ON Semiconductor reserves the right to make changes without further notice to any products herein. ON Semiconductor makes no warranty, representation or guarantee regarding the suitability of its products for any particular purpose, nor does ON Semiconductor assume any liability arising out of the application or use of any product or circuit, and specifically disclaims any and all liability, including without limitation special, consequential or incidental damages. Buyer is responsible for its products and applications using ON Semiconductor products, including compliance with all laws, regulations and safety requirements or standards, regardless of any support or applications information provided by ON Semiconductor. "Typical" parameters which may be provided in ON Semiconductor data sheets and/or specifications can and do vary in different applications and actual performance may vary over time. All operating parameters, including "Typicals" must be validated for each customer application by customer's technical experts. ON Semiconductor does not convey any license under its patent rights nor the rights of others. ON Semiconductor products are not designed, intended, or authorized for use as a critical component in life support systems or any FDA Class 3 medical devices or medical devices with a same or similar classification in a foreign jurisdiction or any devices intended for implantation in the human body. Should Buyer purchase or use ON Semiconductor products for any such unintended or unauthorized application, Buyer shall indemnify and hold ON Semiconductor and its officers, employees, subsidiaries, affiliates, and distributors harmless against all claims, costs, damages, and expenses, and reasonable attorney fees arising out of, directly or indirectly, any claim of personal injury or death associated with such unintended or unauthorized use, even if such claim alleges that ON Semiconductor was negligent regarding the design or manufacture of the part. ON Semiconductor is an Equal Opportunity/Affirmative Action Employer. This literature is subject to all applicable copyright laws and is not for resale in any manner.

PUBLICATION ORDERING INFORMATION

LITERATURE FULFILLMENT:

Literature Distribution Center for ON Semiconductor
19521 E. 32nd Pkwy, Aurora, Colorado 80011 USA
Phone: 303-675-2175 or 800-344-3860 Toll Free USA/Canada
Fax: 303-675-2176 or 800-344-3867 Toll Free USA/Canada
Email: orderlit@onsemi.com

N. American Technical Support: 800-282-9855 Toll Free
USA/Canada
Europe, Middle East and Africa Technical Support:
Phone: 421 33 790 2910
Japan Customer Focus Center
Phone: 81-3-5817-1050

ON Semiconductor Website: www.onsemi.com
Order Literature: <http://www.onsemi.com/orderlit>
For additional information, please contact your local
Sales Representative